

Yetter

...for land's sake

6150-119 MARKER SPACER KIT

1. Remove the two 1/2" bolts securing the armrest to the marker base. These two bolts will not be used again. The lockwashers and nuts will be reused.
2. Place the marker spacer between the armrest and the marker base and secure with two 1/2 x 2-3/4" bolts, lockwashers and nuts.
3. Repeat for other side.

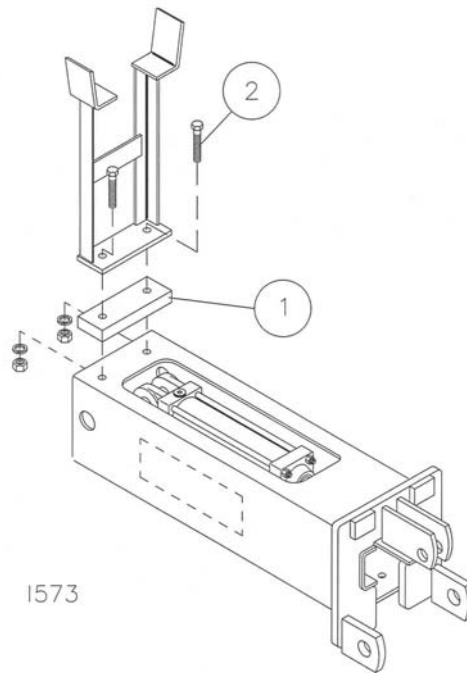

Key	Qty.	Part No.	Description
1	1	6150-421	Marker Spacer
2	2	2502-295	1/2-13 x 2 3/4" HHCS Gr. 5 ZP/

YETTER MANUFACTURING CO.
FOUNDED 1930

Colchester, IL 62326-0358
Toll free: 800/447-5777
309/776-3222 (Fax)
Website: www.yetterco.com
E-mail: info@yetterco.com

Yetter