

# Yetter

## FARM EQUIPMENT

### 6200-184 CLOSE WHEEL ATTACHMENT ASSEMBLY

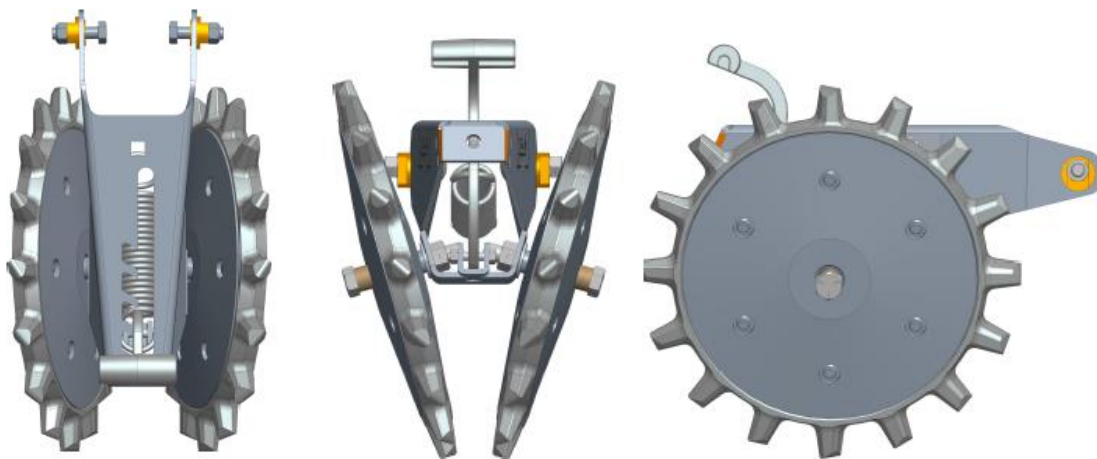

### OWNER'S MANUAL PART IDENTIFICATION 2565-980\_REV\_B • 09/2024

**YETTER MANUFACTURING CO.**

Founded 1930

Colchester, IL 62326

Toll free: (800)447-5777.

Fax: (309)776-3222

Website: [yetterco.com](http://yetterco.com)

E-mail: [info@yetterco.com](mailto:info@yetterco.com)

# YETTER

## FOREWORD

You've just joined an exclusive but rapidly growing club.  
For our part, we want to welcome you to the group and thank you for buying a Yetter product.

We hope your new Yetter products will help you achieve both goals-increase your productivity and increase your efficiency so that you may generate more profit.

This operator's manual has been designed into four major sections: Foreword, Safety Precautions, Installation Instructions and Parts Breakdown.

This **SAFETY ALERT SYMBOL** indicates important safety messages in the manual. When you see this symbol, be alert to the possibility of **PERSONAL INJURY** and carefully read the message that follows.

 **DANGER:** Indicates an imminently hazardous situation which, if not avoided "will" result in death or serious injury. This signal word is to be limited to the most extreme situations

 **WARNING:** Indicates a potentially hazardous situation which, if not avoided, "could" result in death or serious injury.

 **CAUTION:** Indicates a potentially hazardous situation, which if not avoided, "may" result in minor or moderate injury. It may also be used to alert against unsafe practices.

 **NOTICE:** Indicates information considered important, but not hazard related (e.g., messages relating to property damage).

It is the responsibility of the user to read the operator's manual and comply with the safe and correct operating procedure and to lubricate and maintain the product according to the maintenance schedule in the operator's manual.

The user is responsible for inspecting his machine and for having parts repaired or replaced when continued use of the product would cause damage or excessive wear to the other parts.

It is the user's responsibility to deliver his machine to the Yetter dealer who sold him the product for service or replacement of defective parts, which are covered by the warranty policy.

If you are unable to understand or follow the instructions provided in this publication, consult your local Yetter dealer or contact:

### YETTER MANUFACTURING CO.

309/776-4111

800/447-5777

309/776-3222 (FAX)

Website: [www.yetterco.com](http://www.yetterco.com)

E-mail: [info@yetterco.com](mailto:info@yetterco.com)

### WARRANTY POLICY

Yetter Manufacturing warrants all products manufactured and sold by it against defects in material. This warranty being expressly limited to replacement at the factory of such parts or products as will appear to be defective after inspection. This warranty does not obligate the Company to bear cost of labor in replacement of parts. It is the policy of the company to make improvements without incurring obligations to add them to any unit already sold. No warranty is made or authorized to be made, other than herein set forth. This warranty is in effect for one year after purchase.

Dealer : \_\_\_\_\_

**Yetter Manufacturing warrants its own products only and cannot be responsible for damage to equipment on which mounted.**



## SAFETY PRECAUTIONS



A brief description of signal words that may be used in this manual:

**DANGER:** Indicates an imminently hazardous situation which, if not avoided “will” result in death or serious injury. This signal word is to be limited to the most extreme situations.

**WARNING:** Indicates a potentially hazardous situation which, if not avoided, “could” result in death or serious injury.

**CAUTION:** Indicates a potentially hazardous situation, which if not avoided, “may” result in minor or moderate injury. It may also be used to alert against unsafe practices.

**NOTICE:** Indicates information considered important, but not hazard related (e.g., messages relating to property damage).

Consult your implement and tractor operator’s manual for correct and safe operating practices. Be aware of towed implement width and allow safe clearance.

Safety decals are placed on the implement to alert the operator and others to the risk of personal injury or unsafe operation during normal operations and servicing.

1. The safety decals must be kept clean and in good condition to ensure that they are legible.
2. Safety decals must be replaced if they are missing or illegible.
3. When components are replaced during repair or servicing, check that the new components include the necessary safety signs.
4. Replacement safety decals may be obtained from your local dealer.



### WARNING

Read these instructions carefully to acquaint yourself with the Equipment. Working with unfamiliar equipment can lead to accidents.

Never park the equipment on a steep incline or leave the equipment running unattended.

Never clean, lubricate or adjust a machine that is in motion.

Always check that straps are secure.

Make sure latches are in pinned position when moving equipment.

Do not allow children to operate this equipment.

Do not allow riders on the equipment, trailer and/or pick-up.

Use speed and caution dictated by the terrain being traversed. Do not operate on any slope steep enough to cause tipping or loss of control.

Read and understand the operator’s manual and require all other persons who will operate the equipment to do the same.

If operating on public roadways, where legal, be certain all lighting is operating properly and observe all traffic laws.

Beware of increased stopping distances and control effort when operating with implements attached.

Be familiar with all controls and be prepared to stop equipment quickly in an emergency.

**FAILURE TO HEED MAY RESULT IN PERSONAL INJURY OR DEATH.**

## TABLE OF CONTENTS

FOREWARD..... 2  
 WARRANTY..... 2  
 SAFETY INFORMATION.....2-3  
 TORQUE..... 4  
 ASSEMBLY INSTRUCTIONS.....5-6  
 PART IDENTIFICATION.....7

**PLEASE READ, VERY IMPORTANT**



### SECURE PLANTER FRAME AGAINST UNWANTED LOWERING BY APPLYING THE LOCKING MECHANISM ON THE HYDRAULIC CYLINDERS!

## BOLT TORQUE



**NOTICE:** Over-tightening hardware can cause just as much damage as under-tightening. Tightening hardware beyond the recommended range can reduce its shock load capacity.





All hardware is either Grade 5 or Grade 8, unless otherwise noted. Grade 5 cap screws are marked with three radial lines on the head. Grade 8 cap screws are marked with six radial lines on the head. If hardware must be replaced, be sure to replace it with hardware of equal size, strength and thread type. Refer to the torque values chart when tightening hardware.





The chart below is a guide for proper torque. Use it unless a specified torque is called out elsewhere in the manual.

Torque is the force applied to the end of the handle or cheater bar, times the length of the handle or bar.

**Use a torque wrench wherever possible**

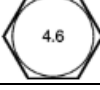
The following table shows torque in ft.-lbs. for coarse thread hardware.

Bolt Diameter and Threads per Inch	 Grade 2	 Grade 5	 A-325	 Grade 8
1/4	6	10		14
5/16	12	20		30
3/8 – 16	25	35		50
7/16 – 14	35	55		80
1/2 – 13	55	85		125
9/16 – 12	75	125		175
5/8 – 11	105	170		235
3/4-10	185	305		425
7/8 – 9	170	445		690
1-8	260	670		1030
1 1/8 – 7	365	900		1460
1 1/4 - 7	515	1275		2060
1 3/8 – 6	675	1675		2700
1 1/2 - 6	900	2150		3500
1 3/4 – 5	1410	3500		5600

Bolt Diameter	 4.6	 8.8	 10.9	 12.9
	4.6	8.8	10.9	12.9
M4	0.9	2.3	3.2	3.8
M5	1.8	4.5	6.5	7.6
M6	3.0	7.7	11.1	13.0
M7	5.0	13.0	18.5	21.7
M8	7.3	18.8	26.9	31.4
M10	14.4	37.2	53.2	62.2
M12	25.2	64.9	92.8	108.5
M14	40.2	103.7	148.4	173.4
M16	62	161	230	269
M18	86	222	318	372
M20	122	314	449	525
M22	166	428	613	716
M24	211	543	777	908
M27	309	796	1139	1331

# ASSEMBLY INSTRUCTIONS

## “V” CLOSING WHEEL ADJUSTMENT

**WARNING:** Raise planter to transport position and install all safety locks before adjusting closing wheels.

Angled closing wheels trail behind the seed opener to close the seed trench left by the opener. Adjusting spring pressure permits proper firming of the soil beside the seed rather than directly above it. An eccentric bushing allows centering the closing wheel on the row to properly apply pressure on both sides of the seed when closing the trench. When adjusted properly, the closing wheels are centered, tighten the bolts holding the closing wheel to the row unit.

**(CLOSING WHEEL ASSEMBLY SHOWN NOT ASSEMBLED TO ROW UNIT FOR VISUAL CLARITY)**

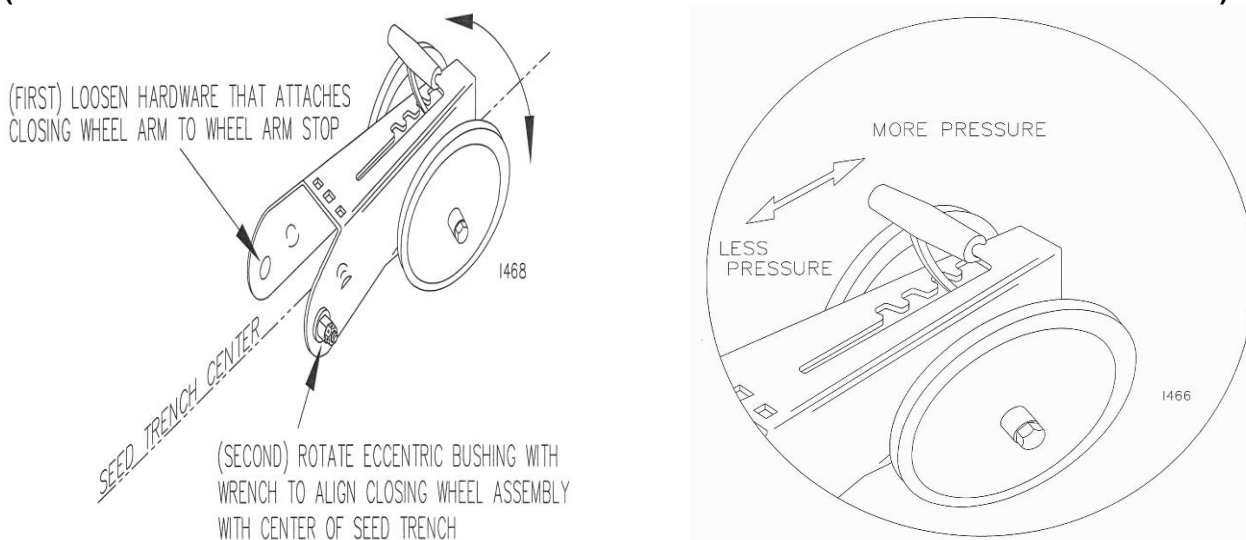

**After setting the planter depth to the correct depth, check the operation of the closing wheels. The closing wheels must** apply enough down pressure to close the seed trench and insure good seed to soil contact. If the seed trench is not being closed properly increase the closing wheel pressure by moving the closing wheel lever rearward.

Closing wheels must not sink into the soil too deeply or the seed placement could be adversely affected, especially when planting shallow. If the closing wheels are applying too much pressure and the seed is being moved by the closing wheels, decrease by moving the lever forward.

Light soils usually require less down pressure, heavy soils more down pressure.

In certain conditions, seed to soil contact and residue flow can be improved by spacing the closing wheels further apart and/or staggering them. To space them further apart, remove the bolt and nut holding the closing wheel to the closing wheel arm, place 5/8" washers (not provided) between the closing wheel and the arm and re-assemble the closing wheel to the arm.

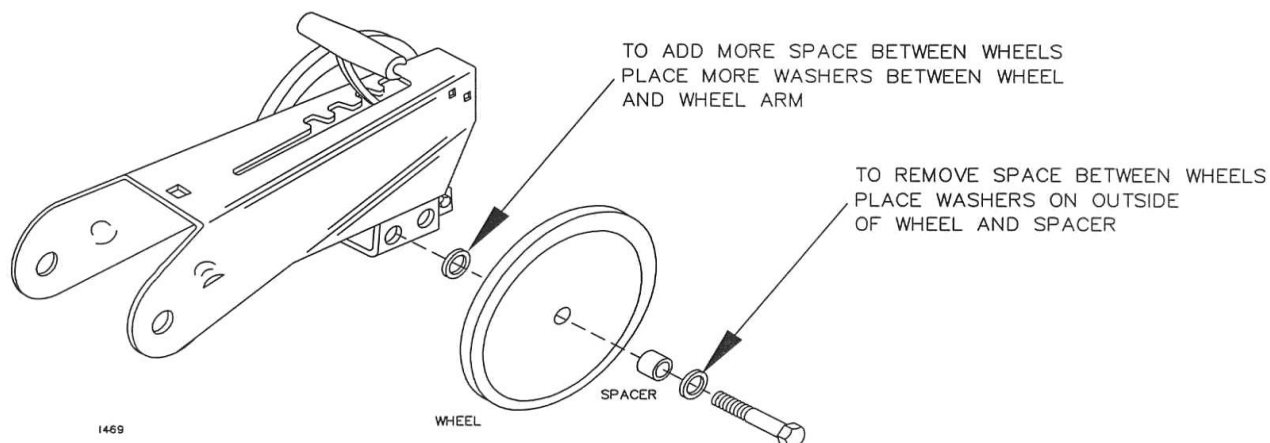

Two mounting holes for each closing wheel are provided in the closing wheel arm. To stagger the closing wheels, remove one closing wheel from the arm and re-assemble it in the other hole in the closing wheel arm.

# LUBRICATION

Oil the closing wheel bushings weekly with a general-purpose oil.  
(CLOSING WHEEL ASSEMBLY SHOWN NOT ASSEMBLED TO ROW UNIT FOR VISUAL CLARITY)

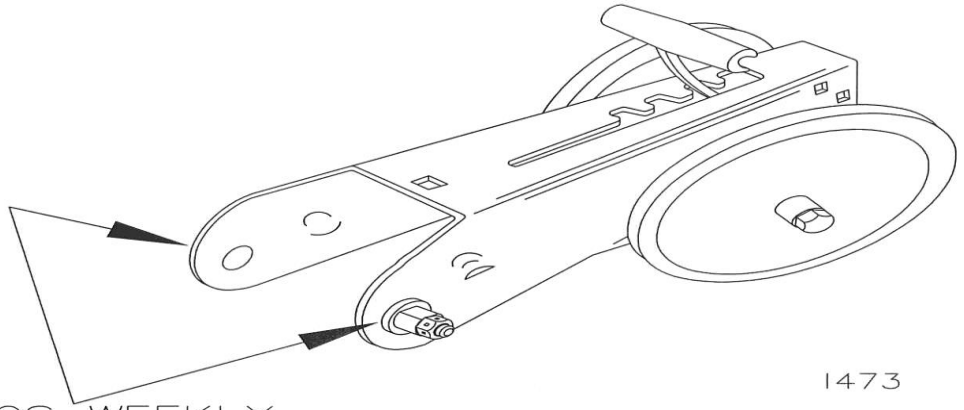

OIL BUSHINGS WEEKLY

1473

# ASSEMBLY & PARTS IDENTIFICATION

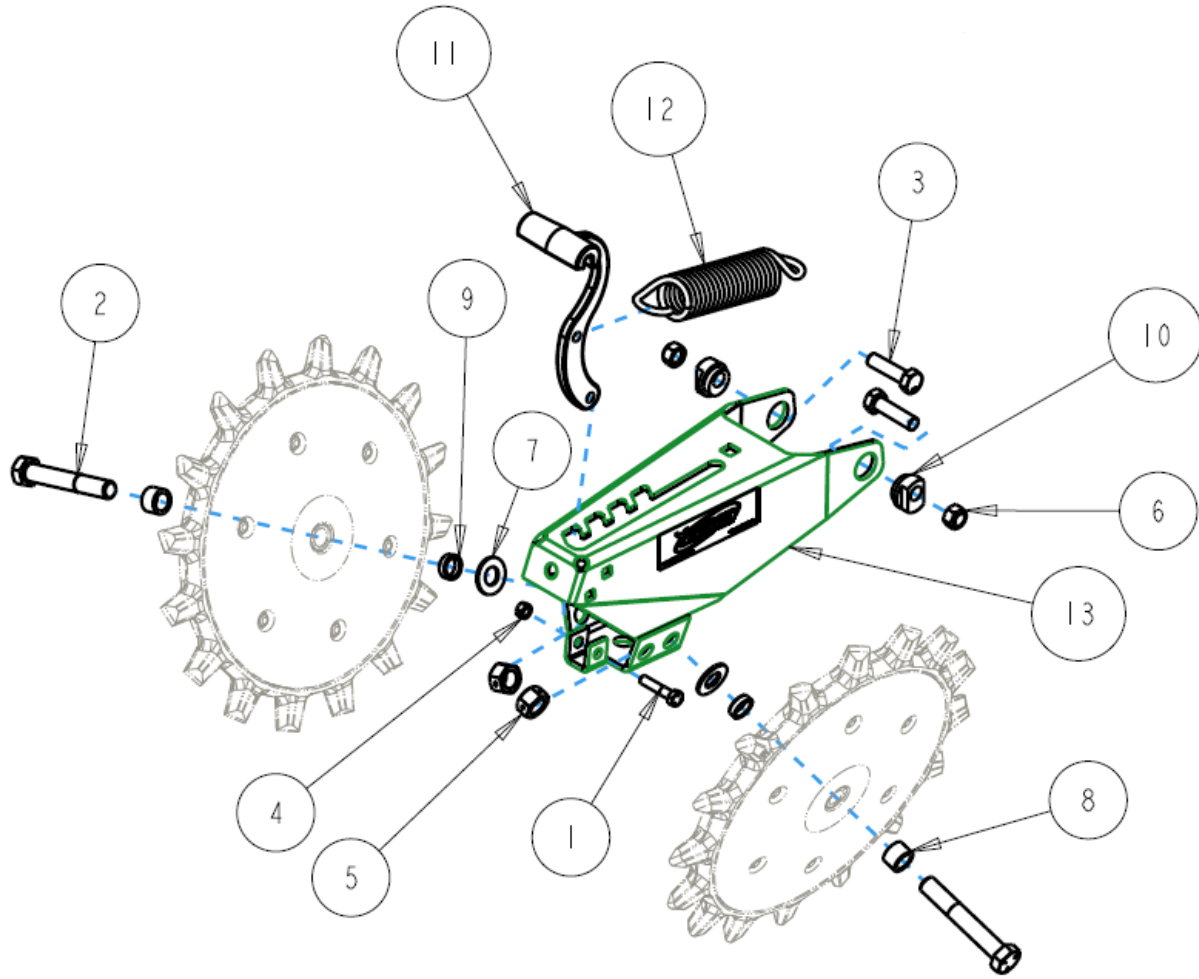

ITEM	PART NO.	DESCRIPTION	QTY
1	2502-206	5/16-18 X 1 1/2 HHCS GR5 ZP	1
2	2502-336	5/8-11 X 4 HHCS GR. 5 ZP	2
3	2505-818	M12-1.75 x 45 GR 8.8 HHCS, ZP	2
4	2520-205	5/16-18 LOCK HEX NUT, GR A, ZP	1
5	2520-459	5/8-11 LOCK HEX NUT, GR B, ZP	2
6	2520-700	HEX LOCKNUT - M12-1.75	2
7	2526-453	5/8 SAE FLATWASHER ZP	2
8	6000-335	9/16" BUSHING	2
9	6000-336	BUSHING PIVOT	2
10	6000-523	ECCENTRIC BUSHING CLOSE WHEEL	2
11	6000-524	CLOSE WHEEL LEVER	1
12	6000-525	CLOSE WHEEL SPRING (PAINTED)	1
13	6200-239	CLOSE WHEEL ARM W.A.	1



A Tradition of Solutions since 1930

Yetter Farm Equipment Co

PO BOX 358 109 S. McDonough

Colchester, IL 62326-0358

Phone: 309-776-4111

Toll Free: 800-447-5777

Email: [info@yetterco.com](mailto:info@yetterco.com)

For updated models and manuals visit the Yetter website:

[www.yetterco.com](http://www.yetterco.com)

© Yetter Farm Equipment Co. All Rights Reserved

2565-980\_REV\_B – 09/2024