



**5000 SERIES
STALK
DEVASTATOR
CORN STALK ROLLER
*PATENTED***

**5000-029B, 5000-030B, 5000-032B, 5000-036, 5000-038
CASE IH 4400 6, 8, & 12 ROW MODELS, 30" NONCHOPPING
OPERATOR'S MANUAL
PART IDENTIFICATION
2565-792_Rev_D – 10/2019**



YETTER MANUFACTURING CO.
Founded 1930

Colchester, IL 62326
Toll Free: (800)447-5777
Fax: (309)776-3222
Website: yetterco.com
E-mail: info@yetterco.com

YETTER

TABLE OF CONTENTS

INTRODUCTION / WARRANTY	2
SAFETY INFORMATION	3-4
BOLT TORQUE / TOOLS REQUIRED	5
ASSEMBLY INSTRUCTIONS.....	6 – 10
OPERATION / MAINTENENCE	11
PART IDENTIFICATION	12 – 18
5000-029B	12
5000-030B	13
5000-032B	14
5000-036	15
5000-038	16
MISC. PART ID	17 – 18
TROUBLESHOOTING	19

FOREWORD

You've just joined an exclusive but rapidly growing club.

For our part, we want to welcome you to the group and thank you for buying a Yetter product.

We hope your new Yetter products will help you achieve both goals-increase your productivity and increase your efficiency so that you may generate more profit.

This operator's manual has been designed into four major sections: Foreword, Safety Precautions, Installation Instructions and Parts Breakdown.



This **SAFETY ALERT SYMBOL** indicates important safety messages in the manual. When you see this symbol, be alert to the possibility of **PERSONAL INJURY** and carefully read the message that follows.

The word **NOTE** is used to convey information that is out of context with the manual text. It contains special information such as specifications, techniques and reference information of a supplementary nature.

The word **IMPORTANT** is used in the text when immediate damage will occur to the machine due to improper technique or operation. Important will

apply to the same information as specified by note only of an immediate and urgent nature.

It is the responsibility of the user to read the operator's manual and comply with the safe and correct operating procedure and to lubricate and maintain the product according to the maintenance schedule in the operator's manual.

The user is responsible for inspecting his machine and for having parts repaired or replaced when continued use of the product would cause damage or excessive wear to the other parts.

It is the user's responsibility to deliver his machine to the Yetter dealer who sold him the product for service or replacement of defective parts, which are covered by the warranty policy.

If you are unable to understand or follow the instructions provided in this publication, consult your local Yetter dealer or contact:

YETTER MANUFACTURING CO.

309/776-4111

800/447-5777

309/776-3222 (FAX)

Website: www.yetterco.com

E-mail: info@yetterco.com

WARRANTY

Yetter Manufacturing warrants all products manufactured and sold by it against defects in material. This warranty being expressly limited to replacement at the factory of such parts or products as shall appear to be defective after inspection. This warranty does not obligate the Company to bear cost of labor in replacement of parts. It is the policy of the Company to make improvements without incurring obligations to add them to any unit already sold. No warranty is made or authorized to be made, other than herein set forth. This warranty is in effect for one year after purchase.

DEALER: _____

Yetter Manufacturing warrants its own products only and cannot be responsible for damages to equipment on which mounted.

BE ALERT!

YOUR SAFETY IS INVOLVED.



WATCH OUT FOR THIS SYMBOL. IT POINTS OUT IMPORTANT SAFETY PRECAUTIONS. IT MEANS: “ATTENTION---BECOME ALERT!”

It is your responsibility as an owner, operator, or supervision to know and instruct everyone using this machine at the time of initial assignment and at least annually thereafter, of the proper operation, precautions, and work hazards which exist in the operation of the machine in accordance with OSHA regulations.

Safety Is No Accident

The following safety instructions, combined with common sense, will save your equipment from needless damage and the operator from unnecessary exposure to personal hazard. Pay special attention to the caution notes in the text. Review this manual at least once a year with all operators.



1. Read and understand the operator's manual before operating this machine. Failure to do so is considered a misuse of the equipment.
2. Make sure equipment is secure before operating.
3. Always keep children away from equipment when operating.
4. Make sure everyone that is not directly involved with the operation is out of the work area before beginning operation.
5. Make sure all safety devices, shields, and guards are in place and functional before beginning operation
6. Shut off all power to adjust, service, or clean.
7. Keep hands, feet, and clothing away from moving parts. It is a good idea to remove all jewelry before operating.
8. Inspect the machine periodically during operation for signs of excessive wear, loose fasteners, and unusual noises.

PLEASE READ, VERY IMPORTANT



SECURE THE CORN HEADER AGAINST UNWANTED LOWERING BY APPLYING THE LOCKING MECHANISM ON HYDRAULIC CYLINDERS!

1. Attach head to combine, lock head to combine
2. Raise the head off the ground and engage safety stop on the feeder house cylinder
3. Turn off the combine engine and remove the key

FOLLOW ALL INSTRUCTIONS GIVEN BY THE COMBINE MANUFACTURER

Subject to the size and weight of the corn header, one or two additional hydraulic cylinders may be required.

The combine manufacturer generally keeps corresponding kits readily available for dealers.

Subject to the design of the corn header & the carry capacity of different combines, the steering axel may require the fitting of additional weights & the rear tires be filled with ballast.



FOLLOW ALL INSTRUCTIONS GIVEN BY THE COMBINE MANUFACTURER

BOLT TORQUE

Important: Over tightening hardware can cause as much damage as when under tightening. Tightening hardware beyond the recommended range can reduce its shock load capacity.

All hardware on the 5000 Devastator is either Grade 5 or Grade 8, unless otherwise noted. Grade 5 cap screws are marked with three radial lines on the head. Grade 8 cap screws are marked with six radial lines on the head. If hardware must be replaced, be sure to replace it with hardware of equal size, strength, and thread type. Refer to the torque values chart when tightening hardware.

The chart below is a guide for proper torque. Use it unless a specified torque is called out elsewhere in the manual.

Torque is the force applied to the end of the handle or cheater bar, times the length of the bar.

Use a torque wrench wherever possible

The following table shows torque in ft-lbs for coarse thread hardware.

Bolt Diameter and Threads per Inch	Grade 2	Grade 5	A-325	Grade 8
1/4	6	10		14
5/16	12	20		30
3/8 – 16	25	35		50
7/16 – 14	35	55		80
1/2 – 13	55	85		125
9/16 – 12	75	125		175
5/8 – 11	105	170		235
3/4-10	185	305		425
7/8 – 9	170	445		690
1-8	260	670		1030
1 1/8 – 7	365	900		1460
1 1/4 - 7	515	1275		2060
1 3/8 – 6	675	1675		2700
1 1/2 - 6	900	2150		3500
1 3/4 – 5	1410	3500		5600

INSTALLATION TOOLS REQUIRED:

- Pneumatic or electric impact driver
- 3/4 & 15/16 size sockets
- 10" impact driver extension
- Ratchet
- 3/4, 15/16, & 1 1/8 size wrenches
- 5/16 Allen Wrench
- Torque Wrench



ASSEMBLY INSTRUCTIONS

Step 1: Attach the 5000-260 mount brackets to the frame using 5/8" X 6 bolts, clamp straps, & 5/8" lock hex nuts. 4408 Folding corn heads will use 4) 5000-288 double mount brackets. Between rows 1-2 & 7-8, 5000-460 spacer blocks, 5/8" X 8" bolts will be used. Mounts between rows 3-4 & 5-6 will not use spacer blocks & will use 5/8" X 6" bolts. 4412 corn heads will use an L Plate to instead of the clamp straps between rows 1-2 & 11-12.

Note: Do not fully tighten hardware until the pivot arms are installed in Step 3. In some situations, the hydraulic cylinder for deck plate adjustments may need repositioned under a different snout. See diagrams on [pages 6 – 7](#) for mount bracket placement.

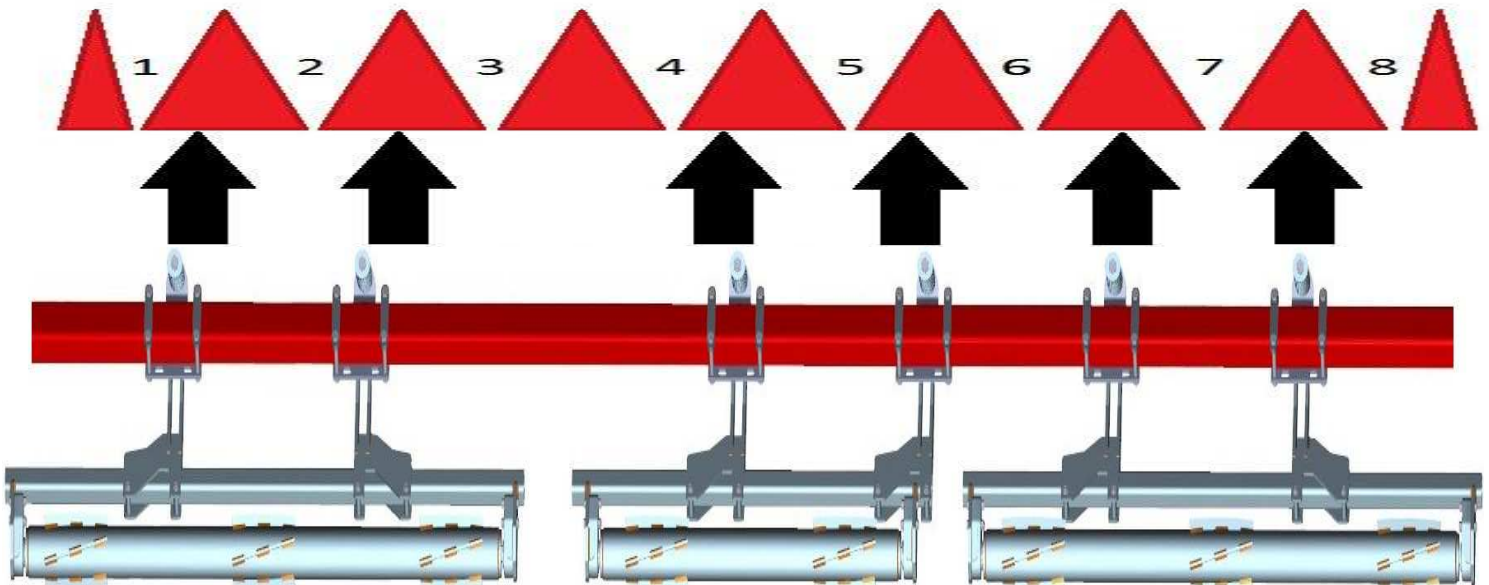
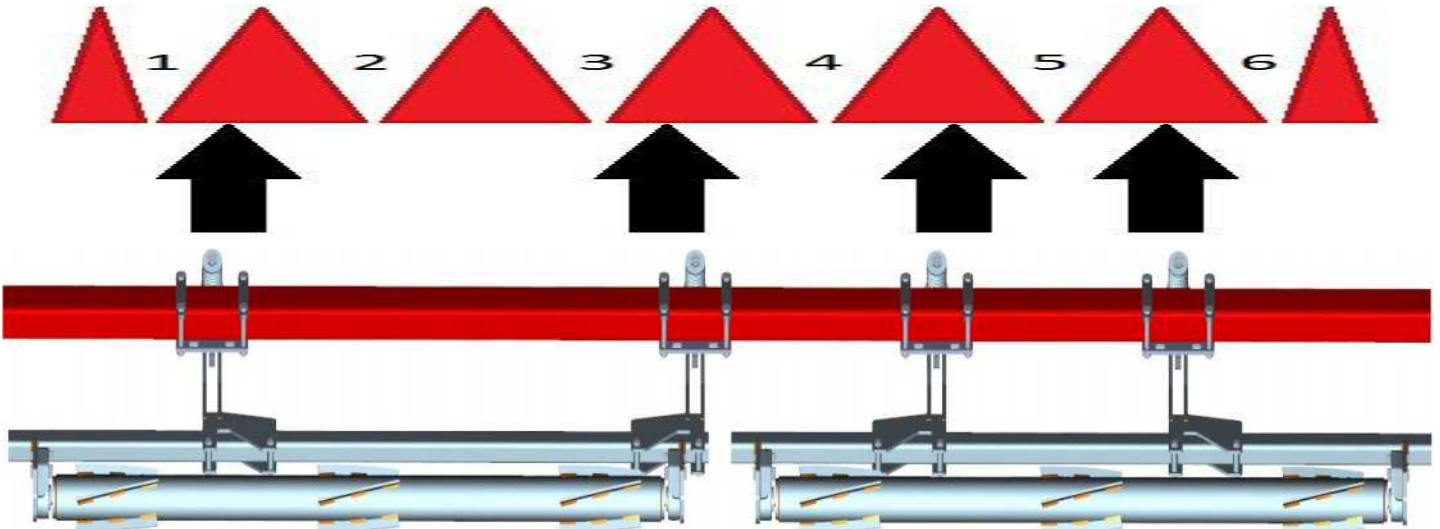
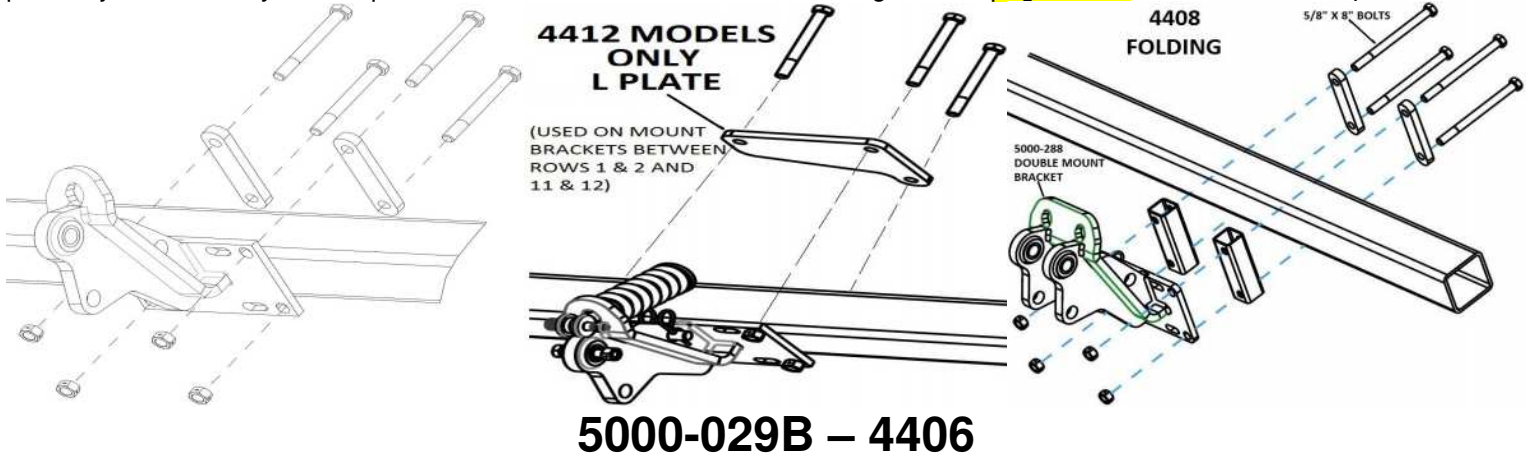

ASSEMBLY INSTRUCTIONS

5000-038 – 4408 (2019 & NEWER)

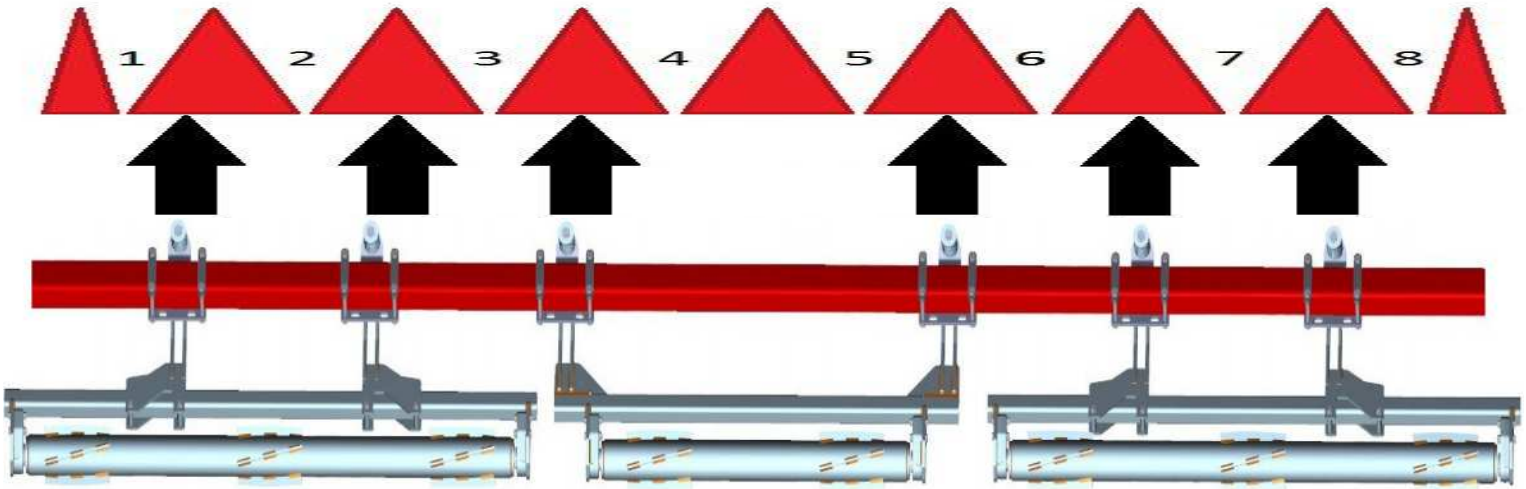

5000-036 – 4408 FOLDING

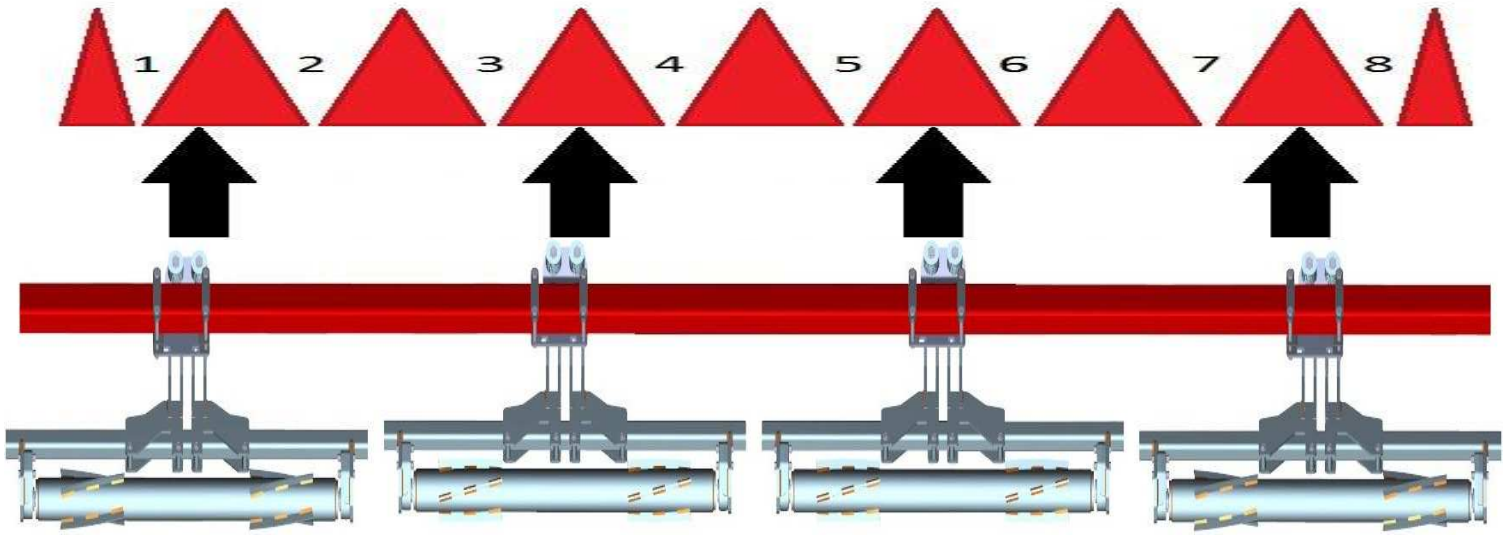

5000-030B – 4412 RIGID OR FOLDING

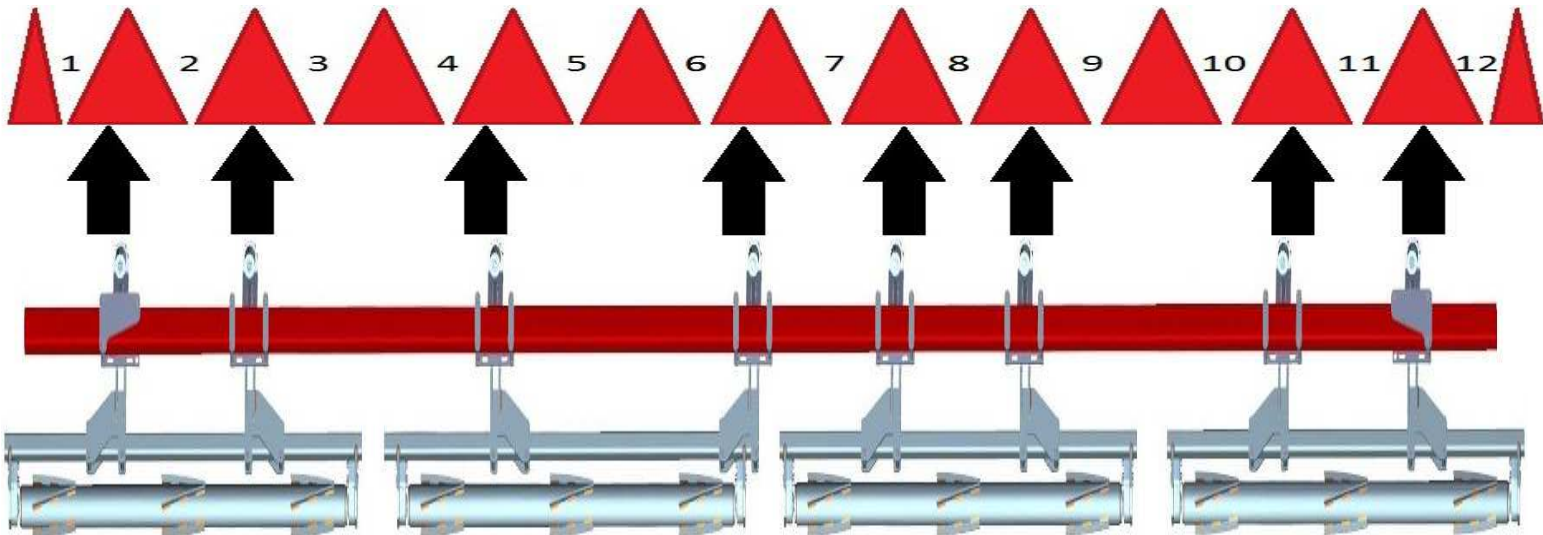

NOTE: THE HYDRAULIC CYLINDER FOR DECK PLATE ADJUSTMENT MAY NEED RELOCATED IF THE CYLINDER INTERFERES WITH WHERE A DEVASTATOR MOUNT BRACKET IS INDICATED TO GO.

ASSEMBLY INSTRUCTIONS

Step 2: Install the 5000-323 lock-up pin in the storage location on the mount brackets. Secure with the supplied hairpin clips.

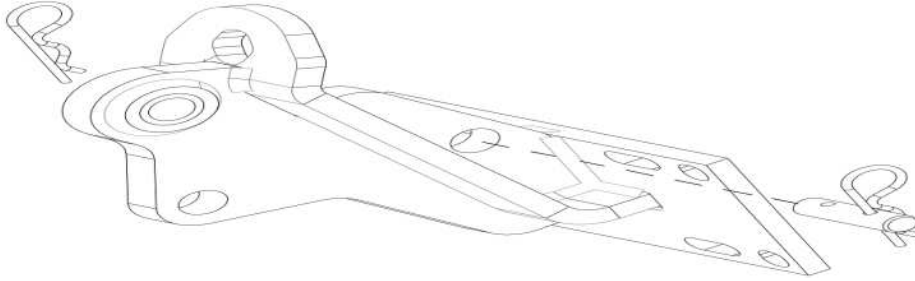

Step 3: Attach the pivot arms to the mount brackets using the 5/8 X 3 bolts, pivot bushings, & lock hex nuts. Fully tighten all hardware. **NOTE:** Make sure the pivot arm orientation matches the diagrams below.

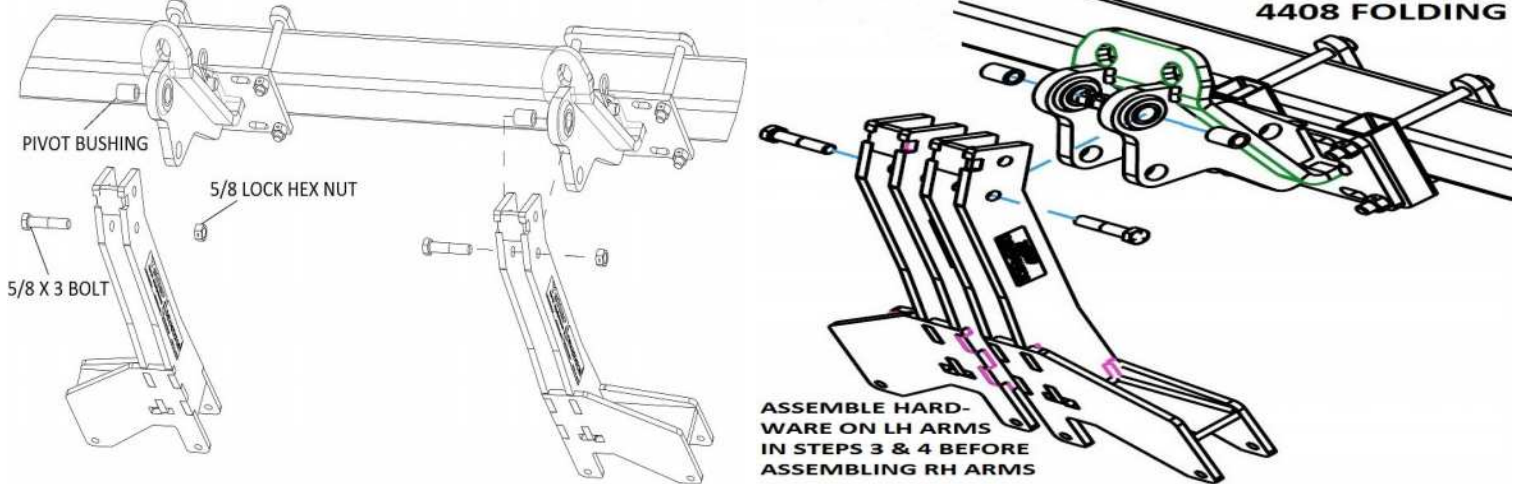

Step 4: Install the pushrods into the mount brackets. Then, attach to the pivot arms with the 5/8 shoulder bolts, washers, & 1/2 jam lock hex nuts. Now install the compression spring, spring bushing, and 3/4 lock hex nuts. **Note:** The washers are installed on each side of the "eye" of the pushrod.

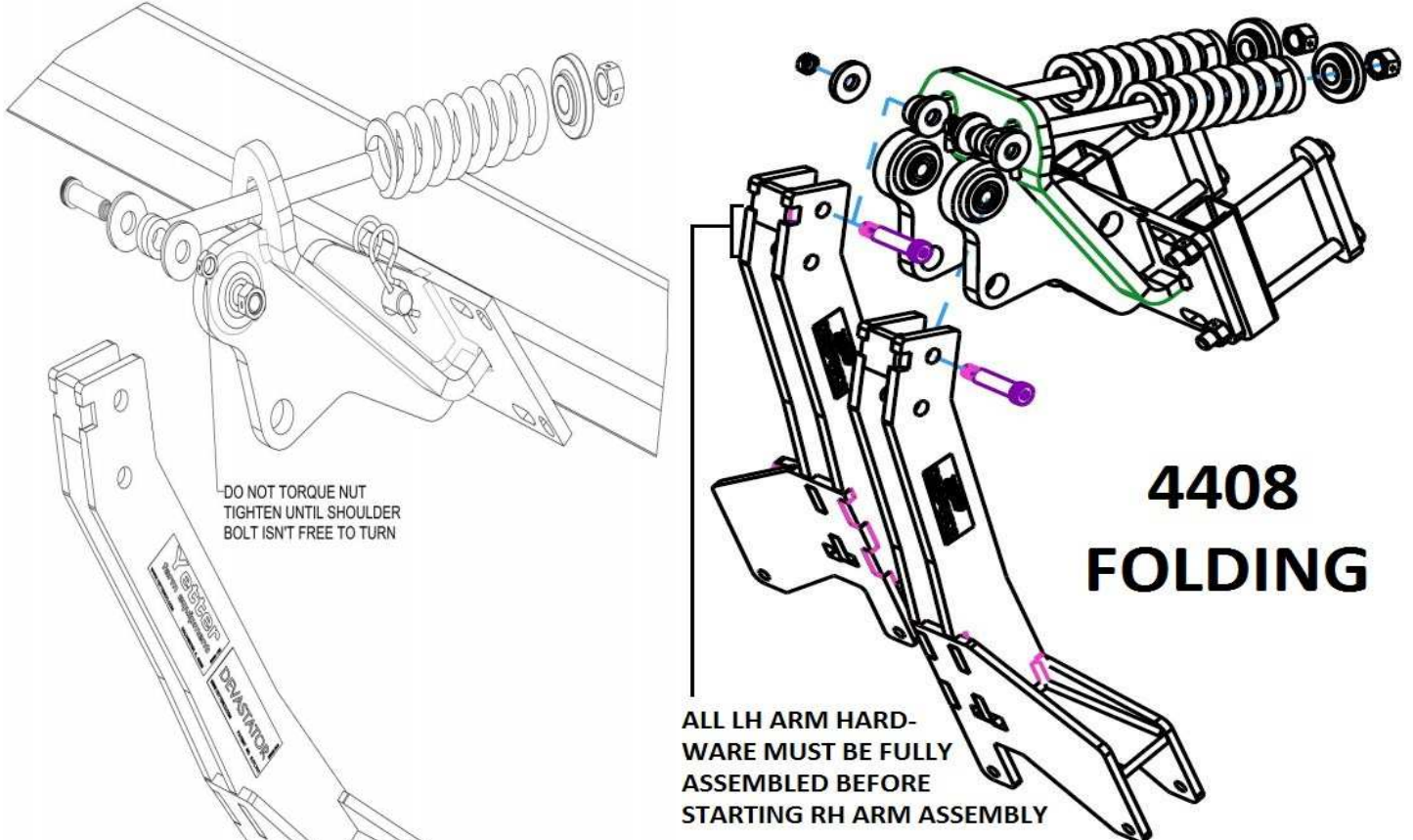

ASSEMBLY INSTRUCTIONS

TIGHTEN UNTIL 3/4" LOCK HEX NUT IS FLUSH WITH THE END OF PUSHROD

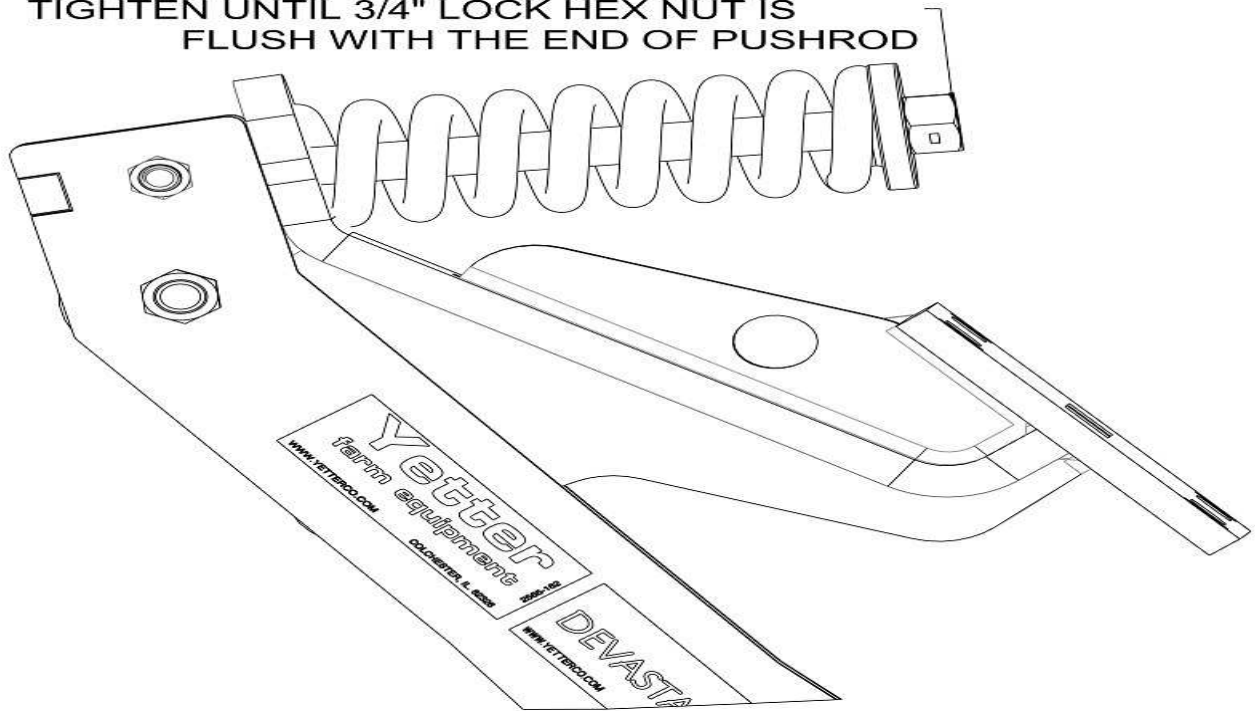

Step 5: Attach the roller mount to the pivot arms using 1/2 X 3-3/4 bolts, spacers, & lock nuts.

NOTE: Make sure the bearing support tabs are on the backside of the bearing mounting plate.

Slide the roller mount side-to-side to clear the end of the corn head. DO NOT tighten hardware.

On 4412 models, the roller mount that is longer in length is to be used between rows 4 – 6.

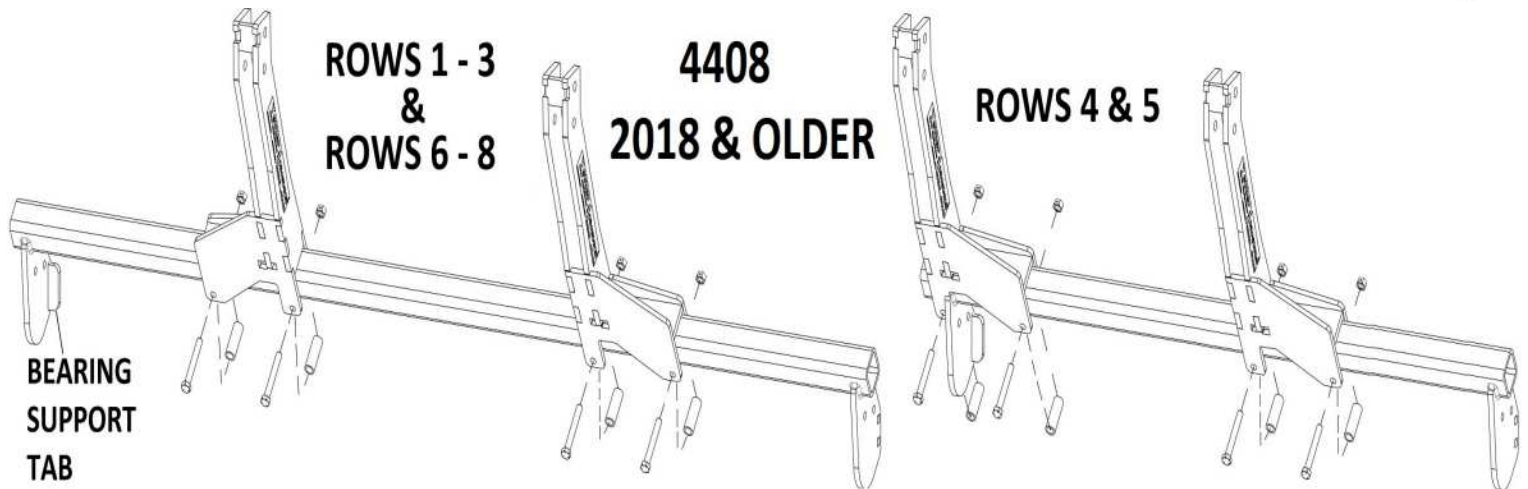
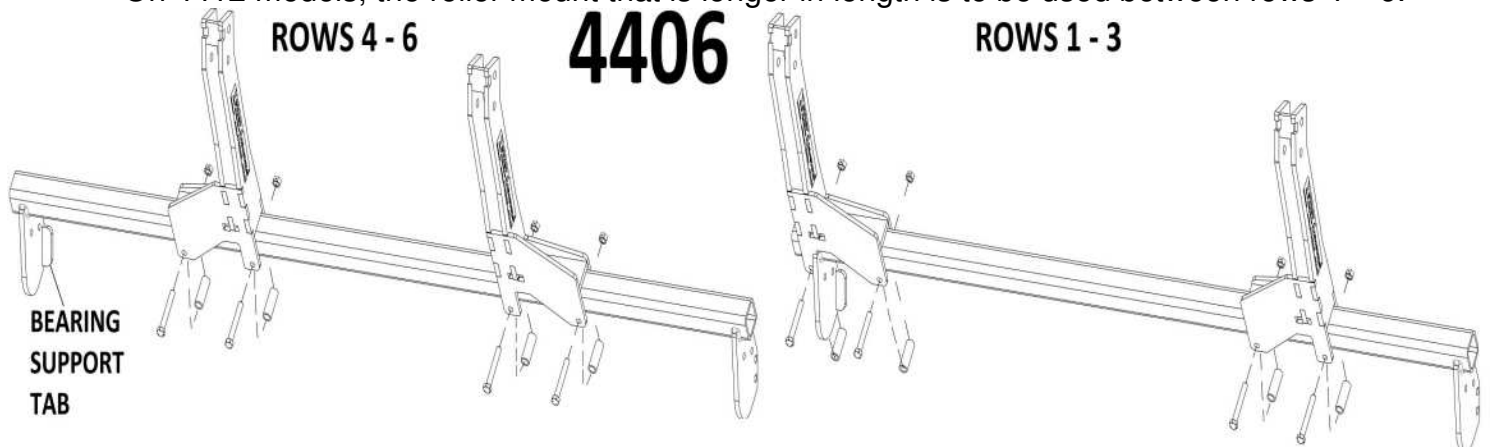

ASSEMBLY INSTRUCTIONS

4408 FOLDING ROWS 1-2, 3-4, 5-6, 7-8

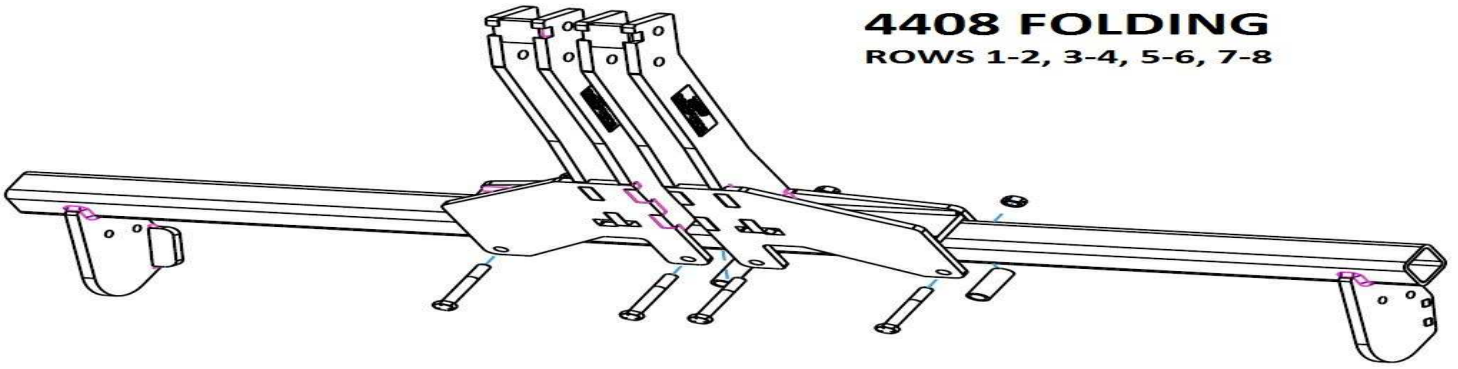

4408 2019 & NEWER

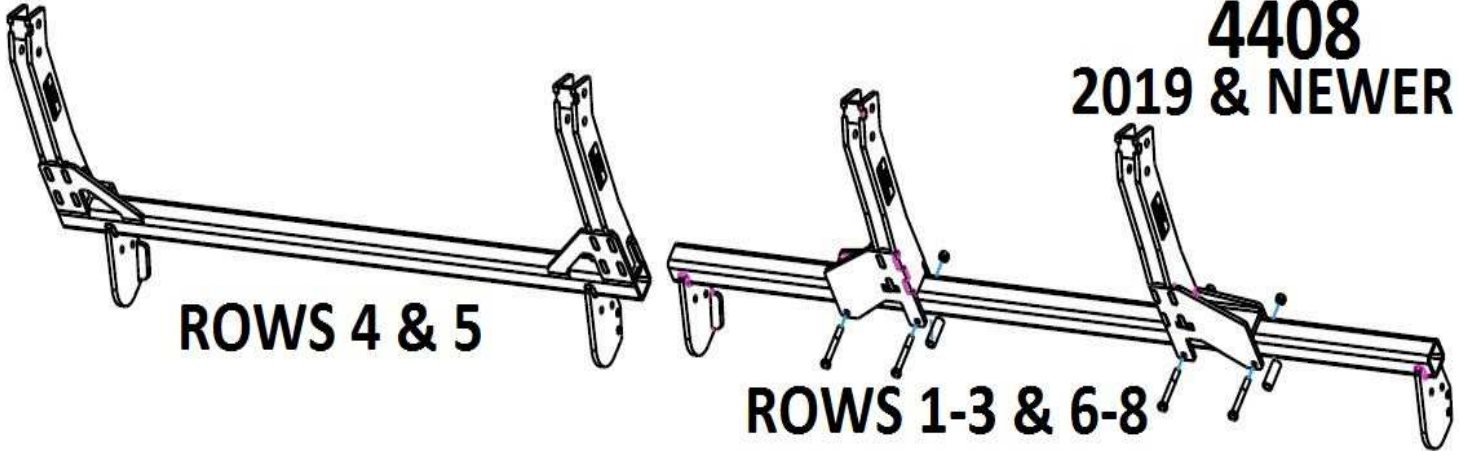

Step 6: Install the shims & bearings onto the rollers. Attach the bearing/roller assembly to the roller mount using the 1/2 X 2 1/2" bolts & lock nuts. Slide the roller mount side to side as need to center the traction bar on the row. 2 row & 3 row roller assemble the same, a 3 row roller is shown below. **Note:** The extended race of the bearing will face toward the roller.

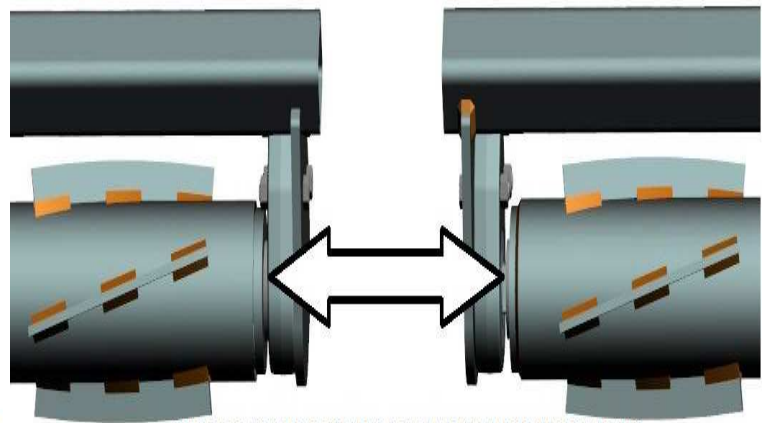
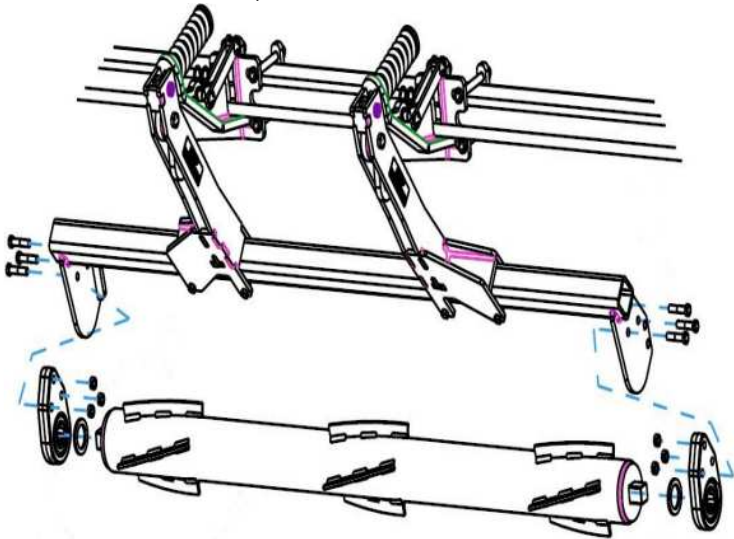

THE SIDE OF THE BEARING ASSEMBLY WHERE THE BEARING IS PROTRUDING MUST BE INSTALLED TOWARD THE ROLLER!

OPERATION

CORN HEAD ANGLE SHOULD BE BETWEEN 23 – 25° FOR OPTIMUM DEVASTATOR PERFORMANCE. USE THE 5000-455 TO CHECK CORN HEAD ANGLE:

- Put the combine on a level surface. Lower the corn head to your normal working head height.
- Place the magnetic protractor on the stripper plate to get the angle. Adjust the feeder house as needed, fore or aft, to achieve 23 – 25 degrees.



BEARING REPLACEMENT

Put the bearing housing in a vice, use a pry bar to turn the bearing in the housing parallel with the slots, remove the old bearing, apply anti-seize lubricant to the interior of the bearing housing, insert the new bearing in the slots, & use a pry bar to move back to position. Wobble the bearing around to help work the lubricant into the outer race of the bearing.



STORAGE

When storing the corn head for the offseason, it is OK for the 5000 Stalk Devastators to hold some weight of the corn head whether stored on the ground or on a trailer. Removing compression springs may help extend the service life. If setting head on ground, use blocks under the front of the head to keep head from rocking forward & making reattaching difficult.

LOCKING UP THE 5000 SERIES STALK DEVASTATOR

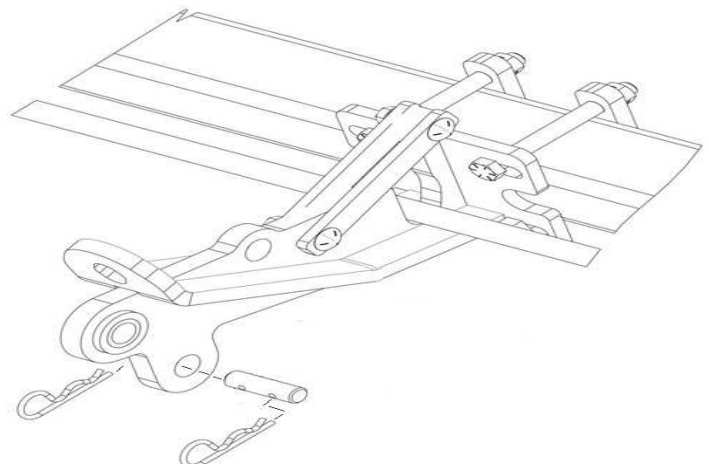

5000-029B PART IDENTIFICATION - 4406

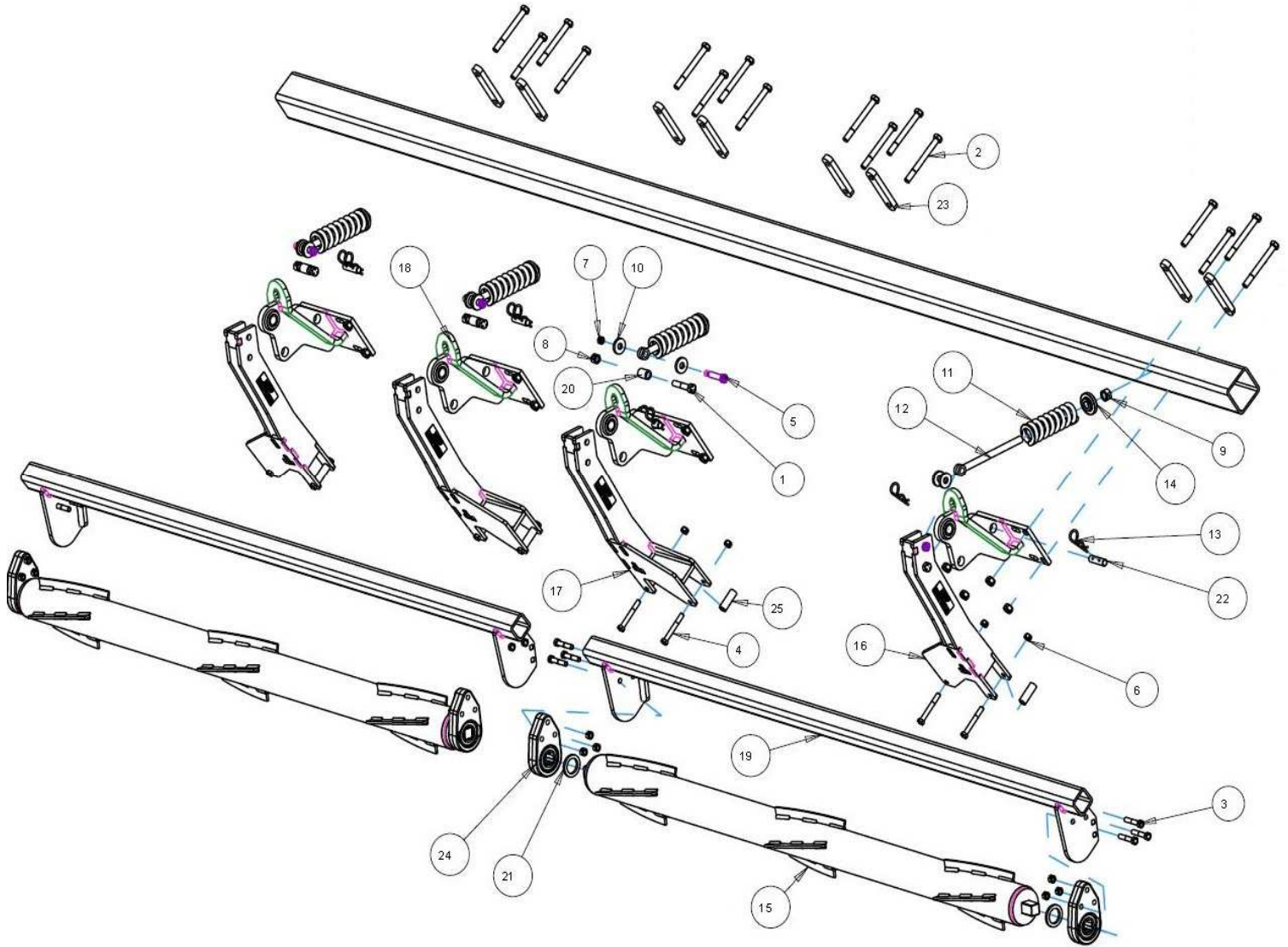

ITEM	PART #	DESCRIPTION	QUANTITY
1	2502-325	5/8" - 11 X 3" HHCS GR 5 ZP	4
2	2502-352	5/8" - 11 X 6" HHCS GR 8 ZP	16
3	2502-353	1/2" - 13 X 2 1/2" HHCS GR 5 ZP	12
4	2502-365	1/2" - 13 X 3 3/4" HHCS GR 5 ZP	8
5	2510-121	5/8" DIAMETER SHOULDER, 2 1/4" LONG SHOULDER, 1/2" - 13	4
6	2520-357	1/2" - 13 LOCK HEX NUT GR A ZP	20
7	2520-364	1/2" - 13 HEX JAM LOCK NUT	4
8	2520-459	5/8" - 11 LOCK HEX NUT GR B ZP	20
9	2520-515	3/4" - 10 LOCK HEX NUT GR A ZP	4
10	2526-449	5/8 FLAT WASHER 1/4" +/- .010 THICK ZP	8
11	2550-709	1/2" WIRE 2.5"OD X 1.5"ID X 7.25" COMPRESSION SPRING	4
12	2570-126	3/4" X 10" EYEBOLT ZP	4
13	2570-465	7 GAUGE HAIRPIN COTTER ZP	8
14	2975-302	2975 SPRING BUSHING PAINTED	4
15	5000-211B	ROLLER W.A. 76"	2
16	5000-256	OVER BEARING ARM 19" LH	2
17	5000-259	OVERBEARING ARM 19" RH	2
18	5000-260	DEVASTATOR MOUNT, CASE 4400	4
19	5000-261	ROLLER MOUNT 3 ROW LONG	2
20	5000-318	PIVOT BUSHING	4
21	5000-322	SHIM WASHER ZP	4
22	5000-323	LOCK UP PIN ZP	4
23	5000-341	4" MOUNT STRAP	8
24	5000-355	BEARING ASSEMBLY	4
	2550-059	DEVASTATOR BEARING (BEARING ONLY)	
25	5000-278	SPACER BUSHING	8

5000-030B PART IDENTIFICATION – 4408 (2018 – OLDER)

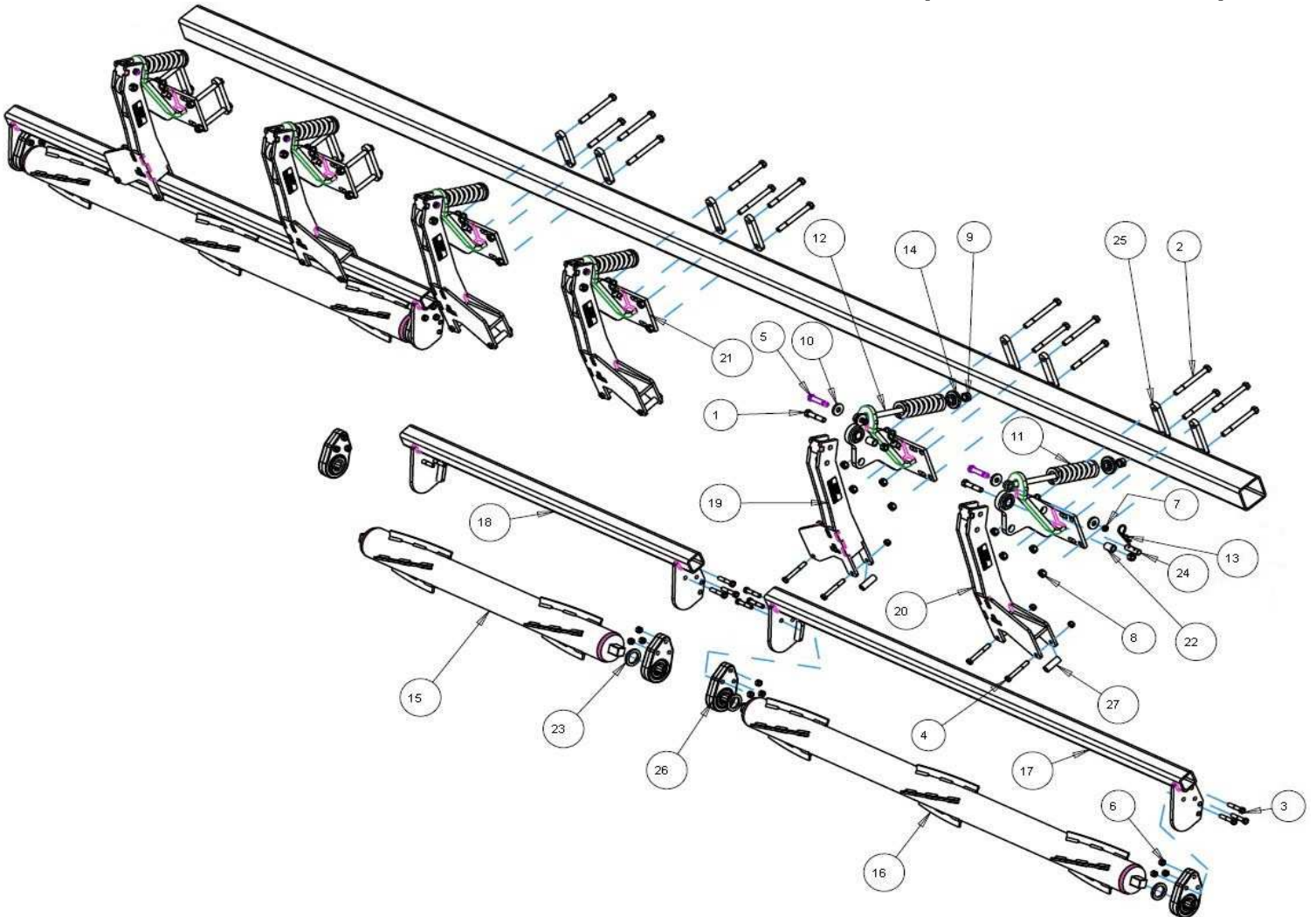

ITEM	PART #	DESCRIPTION	QUANTITY
1	2502-325	5/8" – 11 X 3" HHCS GR 5 ZP	6
2	2502-352	5/8" – 11 X 6" HHCS GR 8 ZP	24
3	2502-353	½" – 13 X 2 ½" HHCS GR 5 ZP	18
4	2502-365	½" – 13 X 3 ¾" HHCS GR 5 ZP	12
5	2510-121	5/8" DIAMETER SHOULDER, 2 ¼" LONG SHOULDER, ½" – 13	6
6	2520-357	½" – 13 LOCK HEX NUT GR A ZP	30
7	2520-364	½" – 13 HEX JAM LOCK NUT	6
8	2520-459	5/8" – 11 LOCK HEX NUT GR B ZP	30
9	2520-515	¾" – 10 LOCK HEX NUT GR A ZP	6
10	2526-449	5/8 FLAT WASHER ¼" +/- .010 THICK ZP	12
11	2550-709	½" WIRE 2.5"OD X 1.5"ID X 7.25" COMPRESSION SPRING	6
12	2570-126	¾" X 10" EYEBOLT ZP	6
13	2570-465	7 GAUGE HAIRPIN COTTER ZP	12
14	2975-302	2975 SPRING BUSHING PAINTED	6
15	5000-203B	ROLLER W.A. 48"	1
16	5000-211B	ROLLER W.A. 76"	2
17	5000-254	ROLLER MOUNT 3 ROW	2
18	5000-255	ROLLER MOUNT W.A.	1
19	5000-256	OVER BEARING ARM 19" LH	2
20	5000-259	OVERBEARING ARM 19" RH	4
21	5000-260	DEVASTATOR MOUNT, CASE 4400	6
22	5000-318	PIVOT BUSHING	6
23	5000-322	SHIM WASHER ZP	6
24	5000-323	LOCK UP PIN ZP	6
25	5000-341	4" MOUNT STRAP	12
26	5000-355	BEARING ASSEMBLY	6
	2550-059	DEVASTATOR BEARING (BEARING ONLY)	
27	5000-278	SPACER BUSHING	12

5000-032B PART IDENTIFICATION 4412 FOLDING OR RIGID

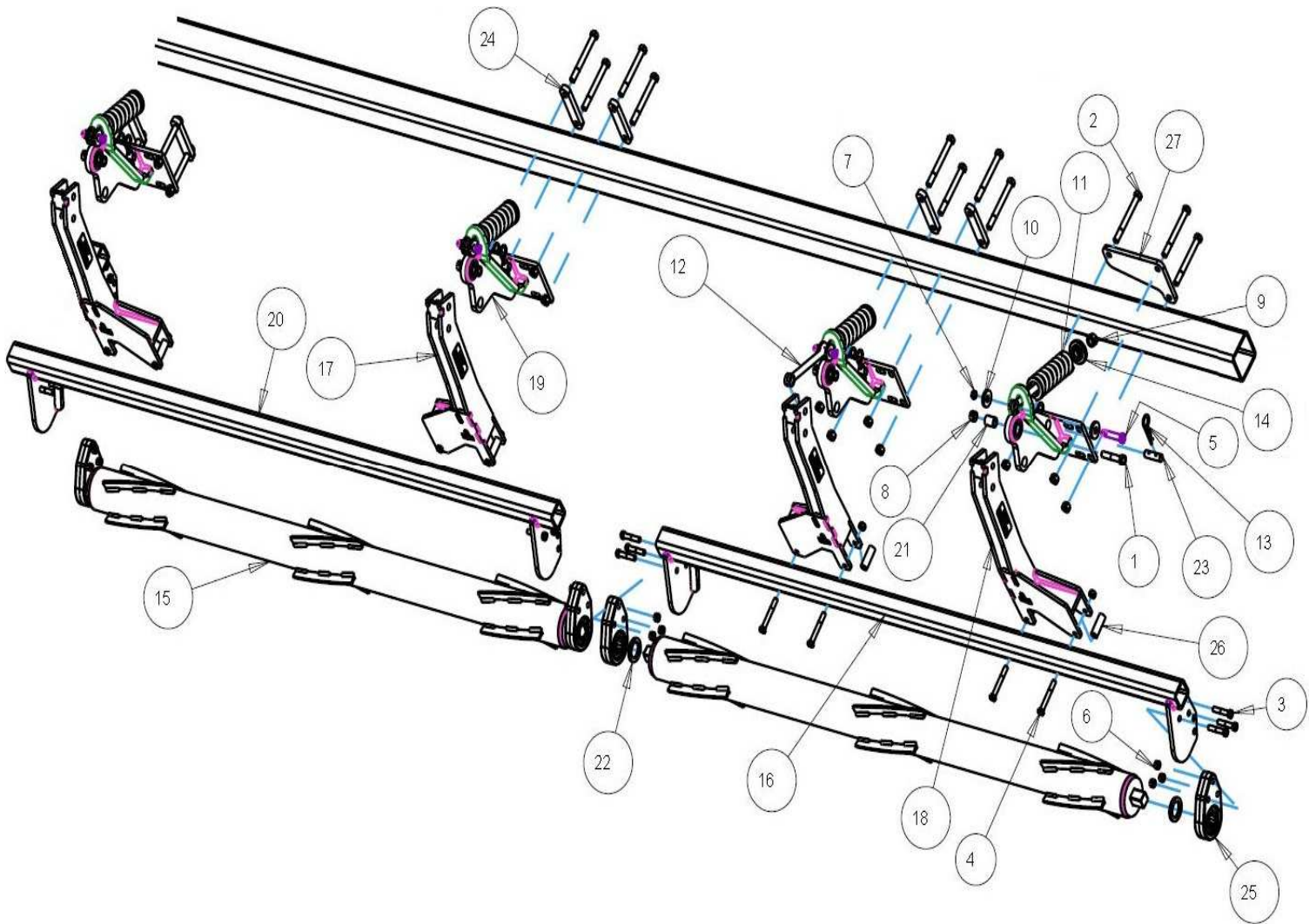

ITEM	PART #	DESCRIPTION	QUANTITY
1	2502-325	5/8" - 11 X 3" HHCS GR 5 ZP	8
2	2502-352	5/8" - 11 X 6" HHCS GR 5 ZP	30
3	2502-353	1/2" - 13 X 2 1/2" HHCS GR 5 ZP	24
4	2502-365	1/2" - 13 X 3 3/4" HHCS GR 5 ZP	16
5	2510-121	5/8" DIAMETER SHOULDER, 2 1/4" LONG SHOULDER, 1/2" - 13	8
6	2520-357	1/2" - 13 LOCK HEX NUT GR A ZP	40
7	2520-364	1/2" - 13 HEX JAM LOCK NUT	8
8	2520-459	5/8" - 11 LOCK HEX NUT GR B ZP	38
9	2520-515	3/4" - 10 LOCK HEX NUT GR A ZP	8
10	2526-449	5/8 FLAT WASHER 1/4" +/- .010 THICK ZP	16
11	2550-709	1/2" WIRE 2.5"OD X 1.5"ID X 7.25" COMPRESSION SPRING	8
12	2570-126	3/4" X 10" EYEBOLT ZP	8
13	2570-465	7 GAUGE HAIRPIN COTTER ZP	16
14	2975-302	2975 SPRING BUSHING PAINTED	8
15	5000-211B	ROLLER W.A. 76"	4
16	5000-254	ROLLER MOUNT 3 ROW	3
17	5000-256	OVER BEARING ARM 19" LH	4
18	5000-259	OVERBEARING ARM 19" RH	4
19	5000-260	DEVASTATOR MOUNT, CASE 4400	8
20	5000-261	ROLLER MOUNT 3 ROW LONG	1
21	5000-318	PIVOT BUSHING	8
22	5000-322	SHIM WASHER ZP	8
23	5000-323	LOCK UP PIN ZP	8
24	5000-341	4" MOUNT STRAP	12
25	5000-355	BEARING ASSEMBLY	8
	2550-059	DEVASTATOR BEARING (BEARING ONLY)	
26	5000-378	SPACER BUSHING	16
27	5000-390	L PLATE 4 X 7.75	2

5000-036 PART IDENTIFICATION 4408 FOLDING

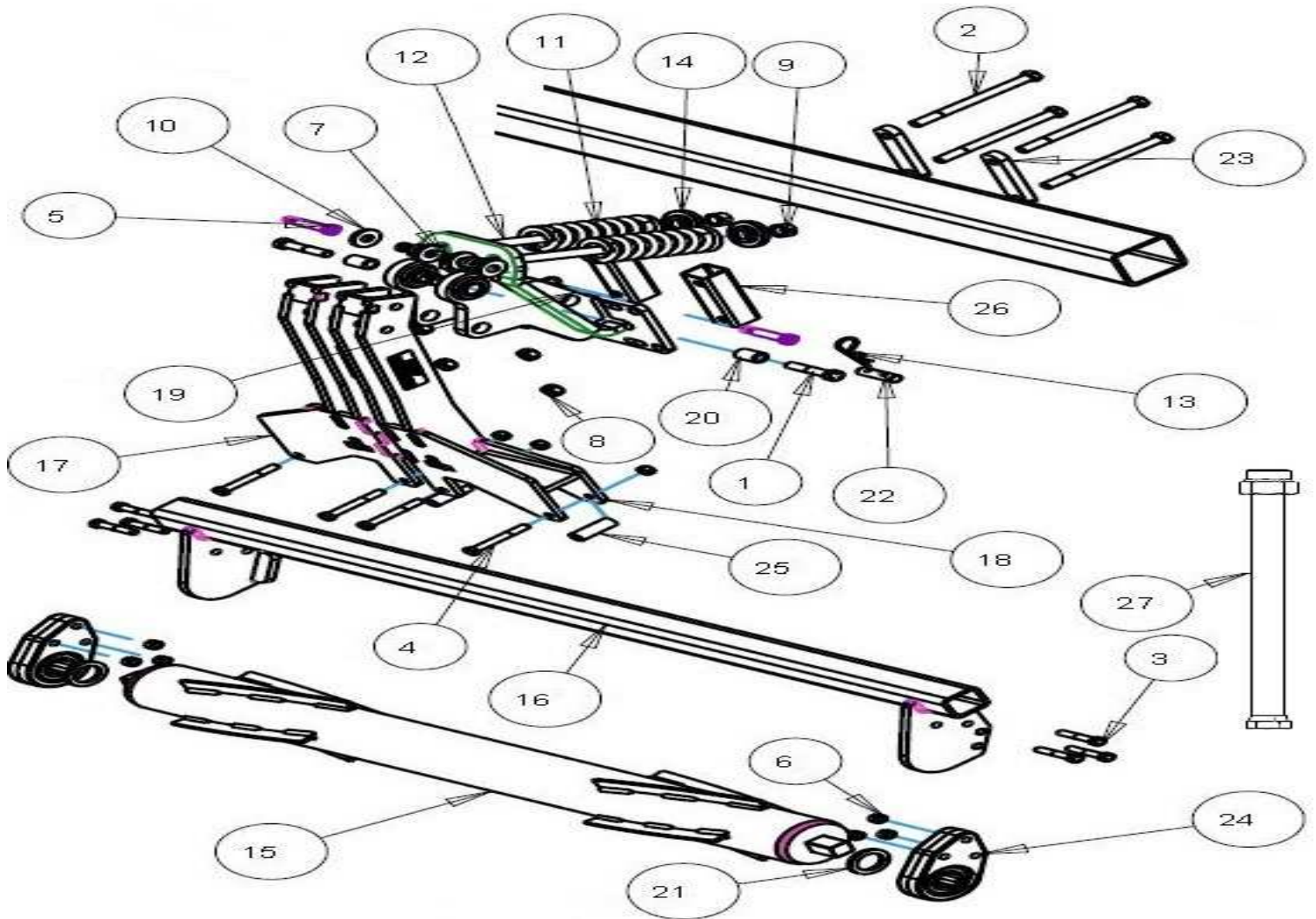

ITEM	PART #	DESCRIPTION	QUANTITY
1	2502-325	5/8" - 11 X 3" HHCS GR 5 ZP	8
2	2502-342	5/8" - 11 X 8" HHCS GR 8 ZP	16
3	2502-353	1/2" - 13 X 2 1/2" HHCS GR 5 ZP	24
4	2502-365	1/2" - 13 X 3 3/4" HHCS GR 5 ZP	16
5	2510-121	5/8" DIAMETER SHOULDER, 2 1/4" LONG SHOULDER, 1/2" - 13	8
6	2520-357	1/2" - 13 LOCK HEX NUT GR A ZP	40
7	2520-364	1/2" - 13 HEX JAM LOCK NUT	8
8	2520-459	5/8" - 11 LOCK HEX NUT GR B ZP	24
9	2520-515	3/4" - 10 LOCK HEX NUT GR A ZP	8
10	2526-449	5/8 FLAT WASHER 1/4" +/- .010 THICK ZP	16
11	2550-709	1/2" WIRE 2.5"OD X 1.5"ID X 7.25" COMPRESSION SPRING	8
12	2570-126	3/4" X 10" EYEBOLT ZP	8
13	2570-465	7 GAUGE HAIRPIN COTTER ZP	16
14	2975-302	2975 SPRING BUSHING PAINTED	8
15	5000-203B	ROLLER W.A. 48"	4
16	5000-255	ROLLER MOUNT W.A.	4
17	5000-256	OVER BEARING ARM 19" LH	4
18	5000-259	OVERBEARING ARM 19" RH	4
19	5000-288	DOUBLE MOUNT W.A., FOLDING CASE 4408	4
20	5000-318	PIVOT BUSHING	8
21	5000-322	SHIM WASHER ZP	8
22	5000-323	LOCK UP PIN ZP	8
23	5000-341	4" MOUNT STRAP	8
24	5000-355	BEARING ASSEMBLY	8
	2550-059	DEVASTATOR BEARING (BEARING ONLY)	
25	5000-278	SPACER BUSHING	16
26	5000-460	1.75" SPACER BLOCK	8
27	2515-369	HYDRAULIC HOSE, 1/4" X 35" WITH 11/16" ORFS MALE TO 11/16"ORFS FEMALE SWIVEL	2

5000-038 PART IDENTIFICATION 4408 (2019 – NEWER)

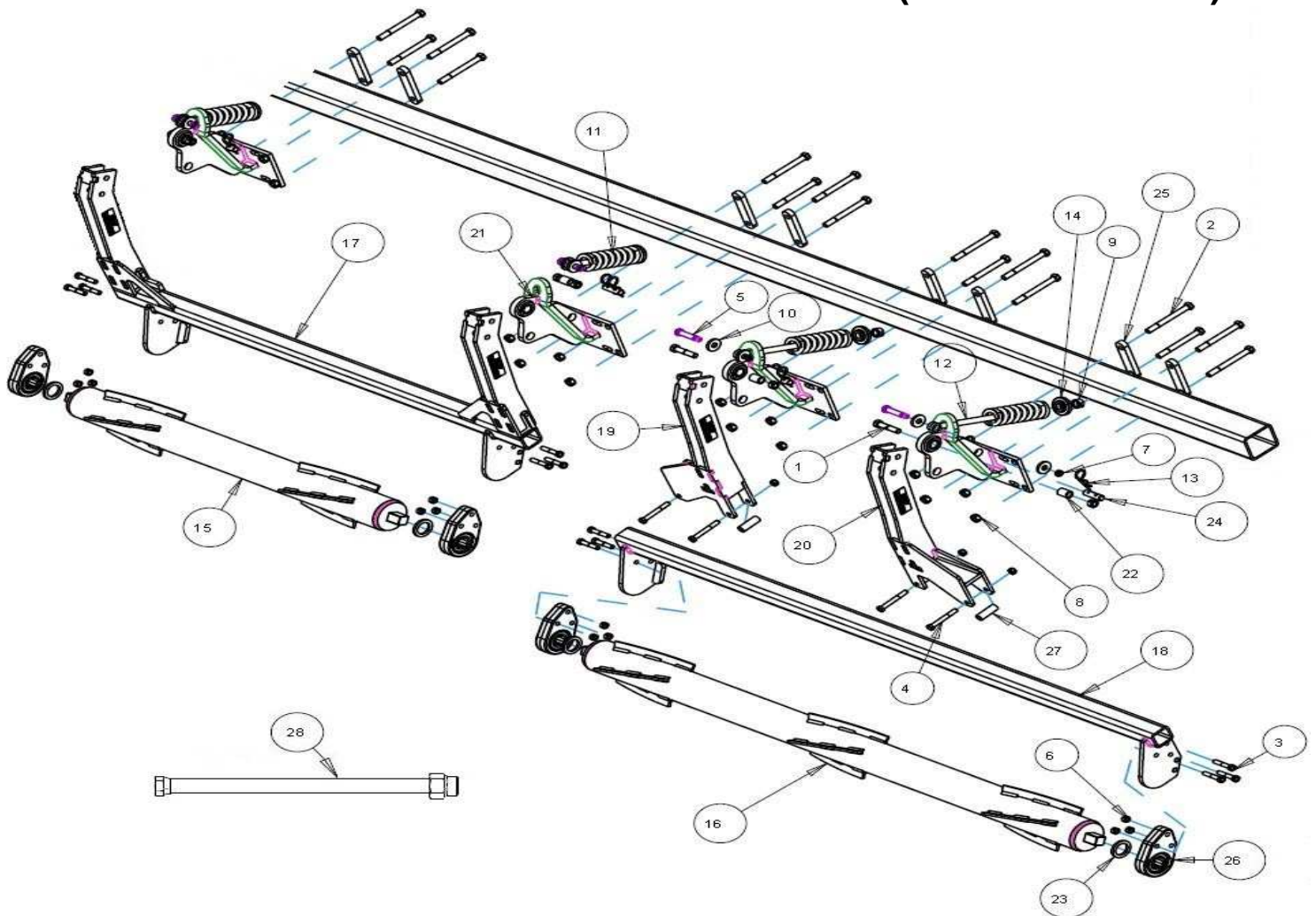

ITEM	PART #	DESCRIPTION	QUANTITY
1	2502-325	5/8" – 11 X 3" HHCS GR 5 ZP	6
2	2502-352	5/8" – 11 X 6" HHCS GR 8 ZP	24
3	2502-353	½" – 13 X 2 ½" HHCS GR 5 ZP	18
4	2502-365	½" – 13 X 3 ¾" HHCS GR 5 ZP	8
5	2510-121	5/8" DIAMETER SHOULDER, 2 ¼" LONG SHOULDER, ½" – 13	6
6	2520-357	½" – 13 LOCK HEX NUT GR A ZP	26
7	2520-364	½" – 13 HEX JAM LOCK NUT	6
8	2520-459	5/8" – 11 LOCK HEX NUT GR B ZP	30
9	2520-515	¾" – 10 LOCK HEX NUT GR A ZP	6
10	2526-449	5/8" FLAT WASHER ¼" +/- .010 THICK ZP	12
11	2550-709	½" WIRE 2.5"OD X 1.5"ID X 7.25" COMPRESSION SPRING	6
12	2570-126	¾" X 10" EYEBOLT ZP	6
13	2570-465	7 GAUGE HAIRPIN COTTER ZP	12
14	2975-302	2975 SPRING BUSHING PAINTED	6
15	5000-203B	ROLLER W.A. 48"	1
16	5000-211B	ROLLER W.A. 76"	2
17	5000-241	PIVOT ARM W.A., WIDE CENTER, 2 ROW	1
18	5000-254	ROLLER MOUNT 3 ROW	2
19	5000-256	OVER BEARING ARM 19" LH	2
20	5000-259	OVERBEARING ARM 19" RH	2
21	5000-260	DEVASTATOR MOUNT, CASE 4400	6
22	5000-318	PIVOT BUSHING	6
23	5000-322	SHIM WASHER ZP	6
24	5000-323	LOCK UP PIN ZP	6
25	5000-341	4" MOUNT STRAP	12
26	5000-355	BEARING ASSEMBLY	6
	2550-059	DEVASTATOR BEARING (BEARING ONLY)	
27	5000-278	SPACER BUSHING	8
28	2515-369	HYDRAULIC HOSE, ¼" X 35" WITH 11/16" ORFS MALE TO 11/16"ORFS FEMALE SWIVEL	2

PART IDENTIFICATION

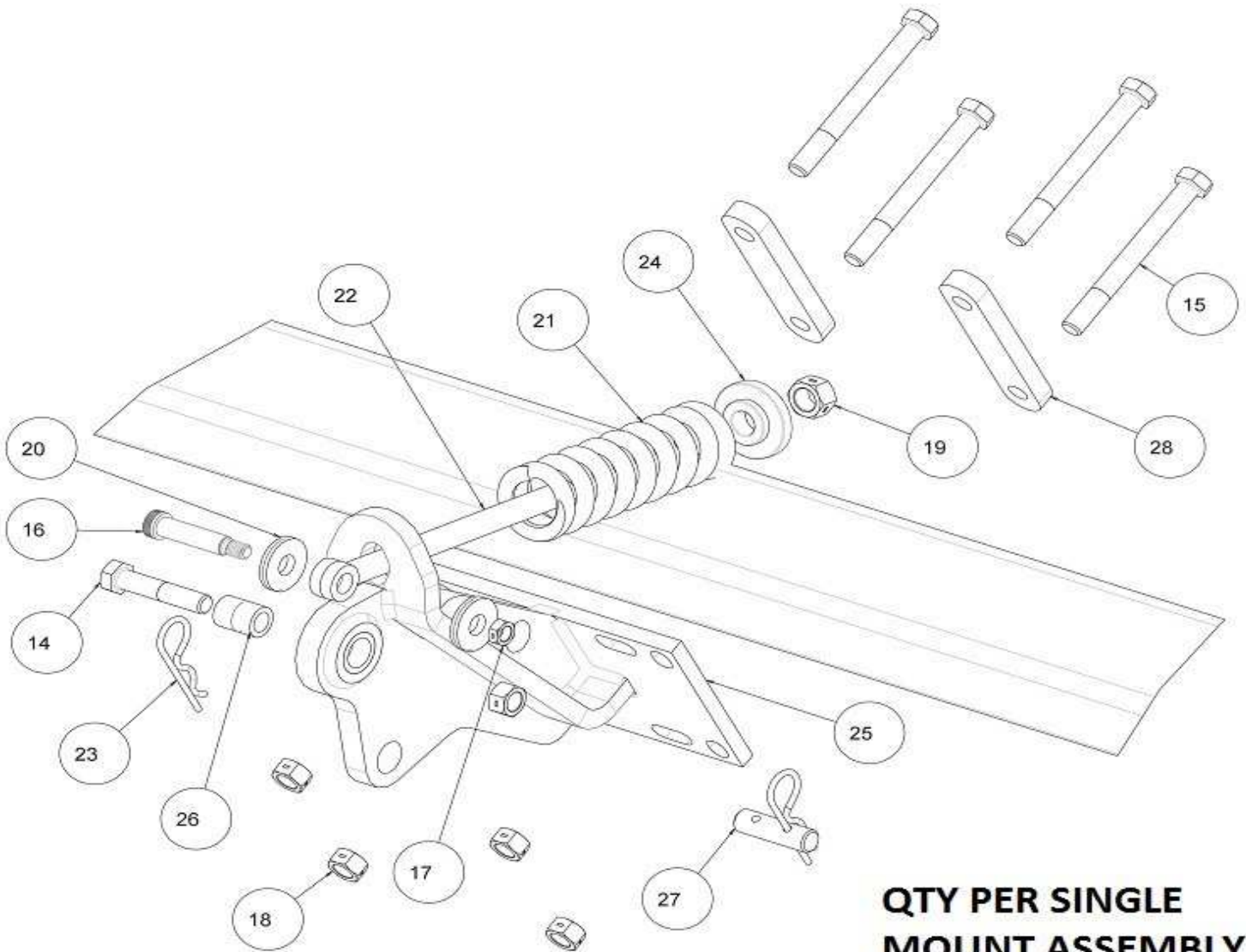

QTY PER SINGLE MOUNT ASSEMBLY

ITEM	PART #	DESCRIPTION	QTY
14	2502-325	5/8-11 X 3 HHCS GR 5	1
15	2502-352	5/8-11 X 6 HHCS GRADE 8 ZYD	4
16	2510-121	5/8" DIA SHLDR, 2-1/4" L SHLDR, 1/2-13	1
17	2520-364	1/2-13 HEX LOCKNUT, JAM, ZP	1
18	2520-459	5/8-11 LOCK HEX NUT, GR B, ZP	4
19	2520-515	3/4-10 LOCK HEX NUT, ZP	1
20	2526-449	5/8ID X 1-3/4 OD X 1/4 FLATWASHER	2
21	2550-709	1/2 WIRE 2-1/2 OD X 1-1/2 ID X 7-1/4 COMP SPRING	1
22	2570-126	3/4 X 10 EYEBOLT, ZP	1
23	2570-465	7 GA HAIRPIN COTTER ZP	2
24	2975-302	2975 SPRING BUSHING "PAINTED"	1
25	5000-260	MOUNT, DEV CASE 4400	1
	2528-369	1.380 OD X 1.00 ID X 1.25 L BEARING SLEEVE	
26	5000-318	PIVOT BUSHING	1
27	5000-323	LOCK UP PIN ZP	1
28	5000-341	4" MOUNT STRAP	2

PARTS IDENTIFICATION

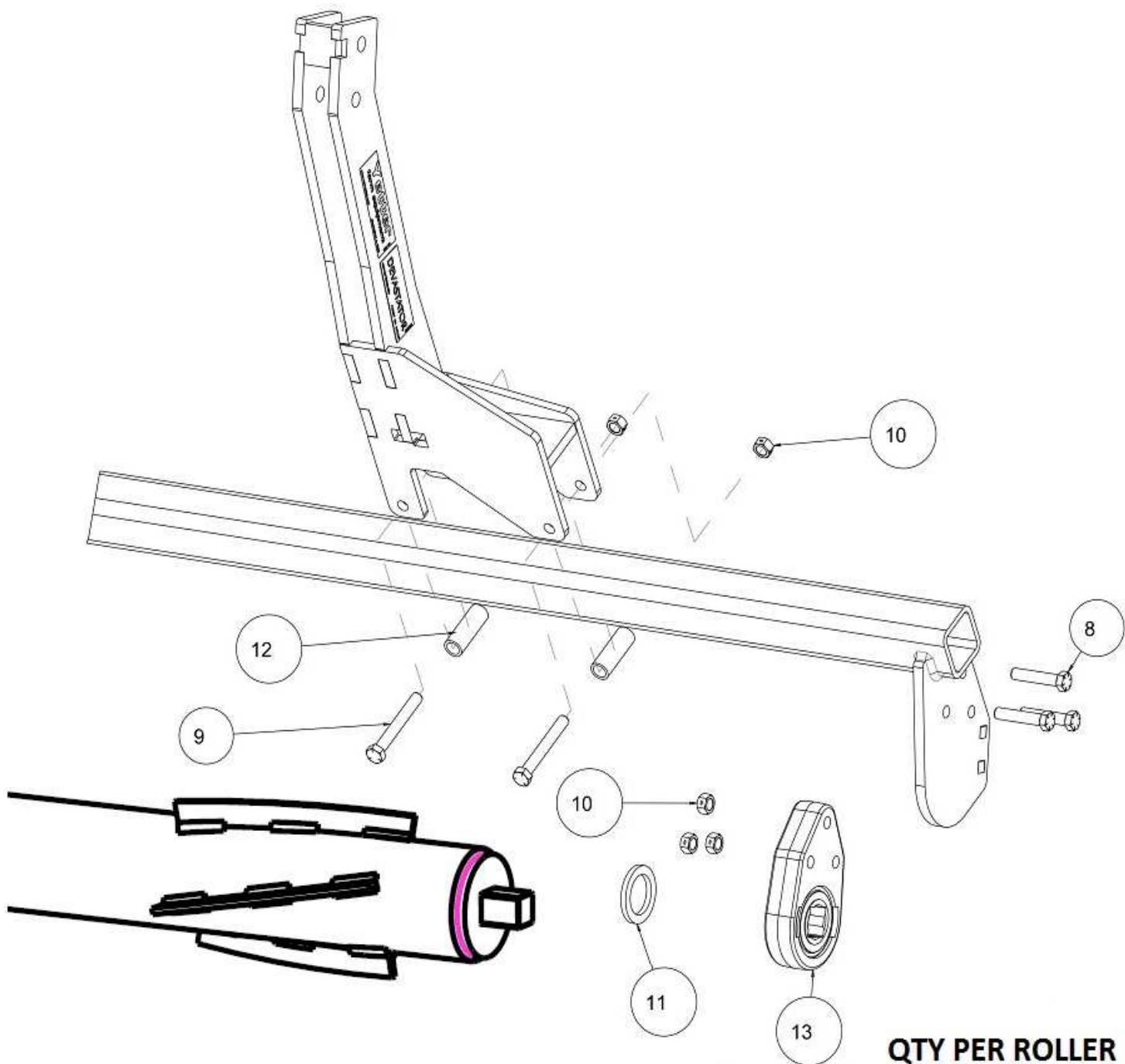

QTY PER ROLLER

ITEM	PART #	DESCRIPTION	QTY
8	2502-353	1/2-13 X 2 1/2HHCS GR8 ZYD	6
9	2502-365	1/2-13 X 3-3/4 HHCS GR5 YD	4
10	2520-357	1/2-13 LOCK HEX NUT, GR A, ZP	10
11	5000-322	SHIM WASHER ZP	2
12	5000-378	SPACER BUSHING	4
13	5000-355	BEARING ASSEMBLY	2
	2550-059	DEVASTATOR BEARING ONLY (SERVICE PART)	2

TROUBLESHOOTING

ISSUE	CAUSE	CORRECTIVE ACTION
Residue Plugging	<ol style="list-style-type: none"> 1. Incorrect Head Angle 2. Roller Mount Tube incorrectly installed 3. Pivot arm orientation incorrect 4. Bearing installed incorrectly 5. Intermeshing snapping rolls 6. Too much Spring Tension 	<ol style="list-style-type: none"> 1. Adjust head angle to 23 – 25 degrees (see page 11) 2. Make sure the Bearing Support Tab is on the backside of the Roller Mount Tube 3. Reposition the pivot arm so that it offsets under the snout & not under the row 4. Make sure the side of the bearing that protrudes outside of the cast housing is facing toward the roller (each roller should spin freely by hand) 5. Order the 5000-080 Set Back Kit (order 2 per roller) 6. Back the nut off of the push rod until the nut is flush
Stalk aren't "devastated"	<ol style="list-style-type: none"> 1. Insufficient spring down pressure 2. Operating corn head too high 	<ol style="list-style-type: none"> 1. Tighten push rod nut on spring bushing more 2. Lower corn head until the rollers engage
Corn Head won't fit on head cart	<ol style="list-style-type: none"> 1. Devastators bottom out 2. Roller won't clear cart tire 3. Header parking stand not touching the head cart saddle 	<ol style="list-style-type: none"> 1. Adjust top rail & saddles higher on cart 2. Order 5000-082 Lift Kit (raises roller 2") 3. Slide the header parking stand down until contact with head cart saddle is made.





A Tradition of Solutions since 1930

Yetter Farm Equipment Co

PO BOX 358 109 S. McDonough

Colchester, IL 62326-0358

Phone: 309-776-4111

Toll Free: 800-447-5777

Email: info@yetterco.com

For updated models and manuals visit the Yetter website:

www.yetterco.com

© Yetter Farm Equipment Co. All Rights Reserved