

Yetter

FARM EQUIPMENT

5000 SERIES STALK DEVASTATOR CHOPPING / 20", 22", & 30" ROWS CASE CORN HEADS

OWNER'S MANUAL
PART IDENTIFICATION
2565-970 8/2019



YETTER MANUFACTURING CO.

Founded 1930

Colchester, IL 62326

Toll free: (800)447-5777.

Fax: (309)776-3222

Website: yetterco.com

E-mail: info@yetterco.com

YETTER

TABLE OF CONTENTS

FOREWARD.....	2
WARRANTY.....	2
SAFETY INFORMATION.....	3 – 4
TORQUE.....	5
BILL OF MATERIALS / TOOLS NEEDED / PICTORIAL PART LIST.....	6
ASSEMBLY INSTRUCTIONS.....	7 – 11
LOCK UP / OPERATION.....	12
PART IDENTIFICATION.....	13 – 16
TROUBLESHOOTING.....	17

FOREWORD

You've just joined an exclusive but rapidly growing club.

For our part, we want to welcome you to the group and thank you for buying a Yetter product.

We hope your new Yetter products will help you achieve both goals-increase your productivity and increase your efficiency so that you may generate more profit.

This operator's manual has been designed into 4 major sections: Foreword, Safety Precautions, Installation Instructions and Parts Breakdown.



This **SAFETY ALERT SYMBOL** indicates important safety messages in the manual. When you see this symbol, be alert to the possibility of **PERSONAL INJURY** & carefully read the message that follows.

The word **NOTE** is used to convey information that is out of context with the manual text. It contains special information such as specifications, techniques and reference information of a supplementary nature.

The word **IMPORTANT** is used in the text when immediate damage will occur to the machine due to improper technique or operation.

It is the responsibility of the user to read the operator's manual and comply with the safe and correct operating procedure and to lubricate and maintain the product according to the maintenance schedule in the operator's manual.

The user is responsible for inspecting his machine and for having parts repaired or replaced when continued use of the product would cause damage or excessive wear to the other parts.

It is the user's responsibility to deliver his machine to the Yetter dealer who sold him the product for service or replacement of defective parts, which are covered by the warranty policy.

If you are unable to understand or follow the instructions provided in this publication, consult your local Yetter dealer or contact:

YETTER MANUFACTURING CO.

309/776-4111

800/447-5777

309/776-3222 (FAX)

Website: www.yetterco.com

E-mail: info@yetterco.com

WARRANTY

Yetter Manufacturing warrants all products manufactured and sold by it against defects in material. This warranty being expressly limited to replacement at the factory of such parts or products as shall appear to be defective after inspection. This warranty does not obligate the Company to bear cost of labor in replacement of parts. It is the policy of the Company to make improvements without incurring obligations to add them to any unit already sold. No warranty is made or authorized to be made, other than herein set forth. This warranty is in effect for one year after purchase.

DEALER: _____

Yetter Manufacturing warrants its own products only and cannot be responsible for damages to equipment on which mounted.

BE ALERT!

YOUR SAFETY IS INVOLVED



WATCH FOR THIS SYMBOL. IT POINTS OUT IMPORTANT SAFETY PRECAUTIONS. IT MEANS “ATTENTION – BE ALERT!”

It is your responsibility as an owner, operator, or supervision to know and instruct everyone using this machine at the time of initial assignment and at least annually thereafter, of the proper operation, precautions, and work hazards which exist in the operation of the machine in accordance with OSHA regulations.

Safety Is No Accident

The following safety instructions, combined with common sense, will save your equipment from needless damage and the operator from unnecessary exposure to personal hazard. Pay special attention to the caution notes in the text. Review this manual at least once a year with all operators.



1. Read and understand the operator's manual before operating this machine. Failure to do so is considered a misuse of the equipment.
2. Make sure equipment is secure before operating.
3. Always keep children away from equipment when operating.
4. Make sure everyone that is not directly involved with the operation is out of the work area before beginning operation.
5. Make sure all safety devices, shields, and guards are in place and functional before beginning operation
6. Shut off all power to adjust, service, or clean.
7. Keep hands, feet, and clothing away from moving parts. It is a good idea to remove all jewelry before operating.
8. Inspect the machine periodically during operation for signs of excessive wear, loose fasteners, and unusual noises.

PLEASE READ, VERY IMPORTANT



SECURE CORN HEADER AGAINST UNWANTED LOWERING BY APPLYING THE LOCKING MECHANISM ON THE HYDRAULIC CYLINDERS!

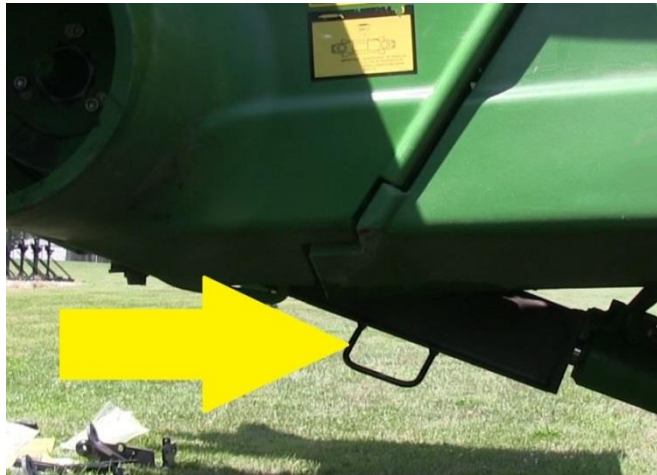

- 1. Attach head to combine, lock head to combine**
- 2. Raise the head off the ground and engage safety stop on the feeder house cylinder.**
- 3. Turn off combine engine and remove the key**

Subject to the size and weight of the corn header, one or two additional hydraulic cylinders may be required.

The combine manufacturer generally keeps corresponding kits readily available for dealers.

Subject to the design of the corn header and the carrying capacity of different combines, the steering axle may require the fitting of additional weights and the rear tires be filled with ballast.

FOLLOW ALL INSTRUCTIONS GIVEN BY THE COMBINE MANUFACTURER

BOLT TORQUE

Important: Over-tightening hardware can cause just as much damage as under-tightening. Tightening hardware beyond the recommended range can reduce its shock load capacity.





All hardware on the 5000 Devastator is either Grade 5 or Grade 8, unless otherwise noted. Grade 5 cap screws are marked with three radial lines on the head. Grade 8 cap screws are marked with six radial lines on the head. If hardware must be replaced, be sure to replace it with hardware of equal size, strength and thread type. Refer to the torque values chart when tightening hardware.

The chart below is a guide for proper torque. Use it unless a specified torque is called out elsewhere in the manual.

Torque is the force applied to the end of the handle or cheater bar, times the length of the handle or bar.

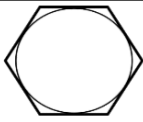
Use a torque wrench wherever possible

The following table shows torque in ft.-lbs. for coarse thread hardware.

Bolt Diameter and Threads per Inch	 Grade 2	 Grade 5	 A-325	 Grade 8
1/4	6		10	14
5/16	12		20	30
3/8 – 16	25		35	50
7/16 – 14	35		55	80
1/2 – 13	55		85	125
9/16 – 12	75		125	175
5/8 – 11	105		170	235
3/4-10	185		305	425
7/8 – 9	170		445	690
1-8	260		670	1030
1 1/8 – 7	365		900	1460
1 1/4 - 7	515		1275	2060
1 3/8 – 6	675		1675	2700
1 1/2 - 6	900		2150	3500
1 3/4 – 5	1410		3500	5600

BILL OF MATERIALS PER KIT

5000-060 – 6R30 Case 4406 – 2) 5000-160 Roller Bearing Bolt Bag, 4) 5000-167 Torsion Pivot Assembly, 4) 5000-173 Torsion Mount Bolt Bag, 2) 5000-272 3R30 Roller W.A., 2) 5000-275 4R20/3R30 Roller Mount W.A., 4) 5000-294 Torsion Arm W.A., 1) 5000-175 Manual Bag

5000-061 – 8R30 Case 4408 – 3) 5000-160 Roller Bearing Bolt Bag, 6) 5000-167 Torsion Pivot Assembly, 6) 5000-173 Torsion Mount Bolt Bag, 1) 5000-268 2R30 Roller W.A., 1) 5000-269 2R30 Roller Mount W.A., 2) 5000-272 3R30 Roller W.A., 2) 5000-275 4R20/3R30 Roller Mount W.A., 6) 5000-294 Torsion Arm W.A., 1) 5000-175 Manual Bag

5000-062 – 12R30 Case 4412 – 4) 5000-160 Roller Bearing Bolt Bag, 8) 5000-167 Torsion Pivot Assembly, 8) 5000-173 Torsion Mount Bolt Bag, 4) 5000-272 3R30 Roller W.A., 4) 5000-275 4R20/3R30 Roller Mount W.A., 8) 5000-294 Torsion Arm W.A., 1) 5000-175 Manual Bag











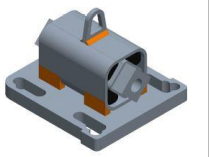





5000-063 – 12R20 Case 4412 – 3) 5000-160 Roller Bearing Bolt Bag, 6) 5000-167 Torsion Pivot Assembly, 6) 5000-173 Torsion Mount Bolt Bag, 3) 5000-267 4R20 Roller W.A., 3) 5000-275 4R20/3R30 Roller Mount W.A., 6) 5000-294 Torsion Arm W.A., 1) 5000-175 Manual Bag

INSTALLATION TOOLS REQUIRED:

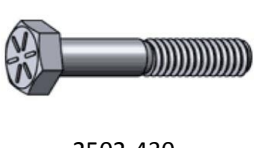
Electric or Pneumatic Impact,
Torque wrench, 1 1/8 socket
& wrench, 15/16 socket,
3/4 socket

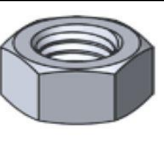

PICTORIAL PART LIST

					
5000-167 Torsion Pivot	5000-267 4R20 Roller W.A.	5000-268 2R30 Roller	5000-269 2R30 Roller Mount	5000-272 3R30 Roller	5000-275 - 2R30/ 4R20 Roller Mount
					
5000-294 Torsion Pivot Arm	5000-355 Bearing Assembly	5000-421 Roller Spacer Bushing	5000-468 Spacer	5000-469 Security Cap	2502-430 3/4" – 10 X 8" Hex Head Bolt Gr 8 ZP
					
2505-343 1/2" – 13 X 2 1/2" Carriage Bolt Gr 5 ZP	2520-357 1/2" Lock Hex Nut	2520-476 5/8" Hex Flange Nut	2520-604 3/4" Hex Flange Nut	2570-568 - 1/2" X 2 1/2" X 3 1/2" U-Bolt	2570-588 – 5/8" X 4" X 5 1/2" U-Bolt

ASSEMBLY INSTRUCTIONS

BELOW ARE RECOMMENDED LOCATIONS OF THE TORSION PIVOT ASSEMBLY, ALTERNATE LOCATIONS MAY BE USED IF INTERFERENCE OCCURS!

5000-060 6 ROW 30"

Arrows indicate 5000-167 Torsion Pivot locations

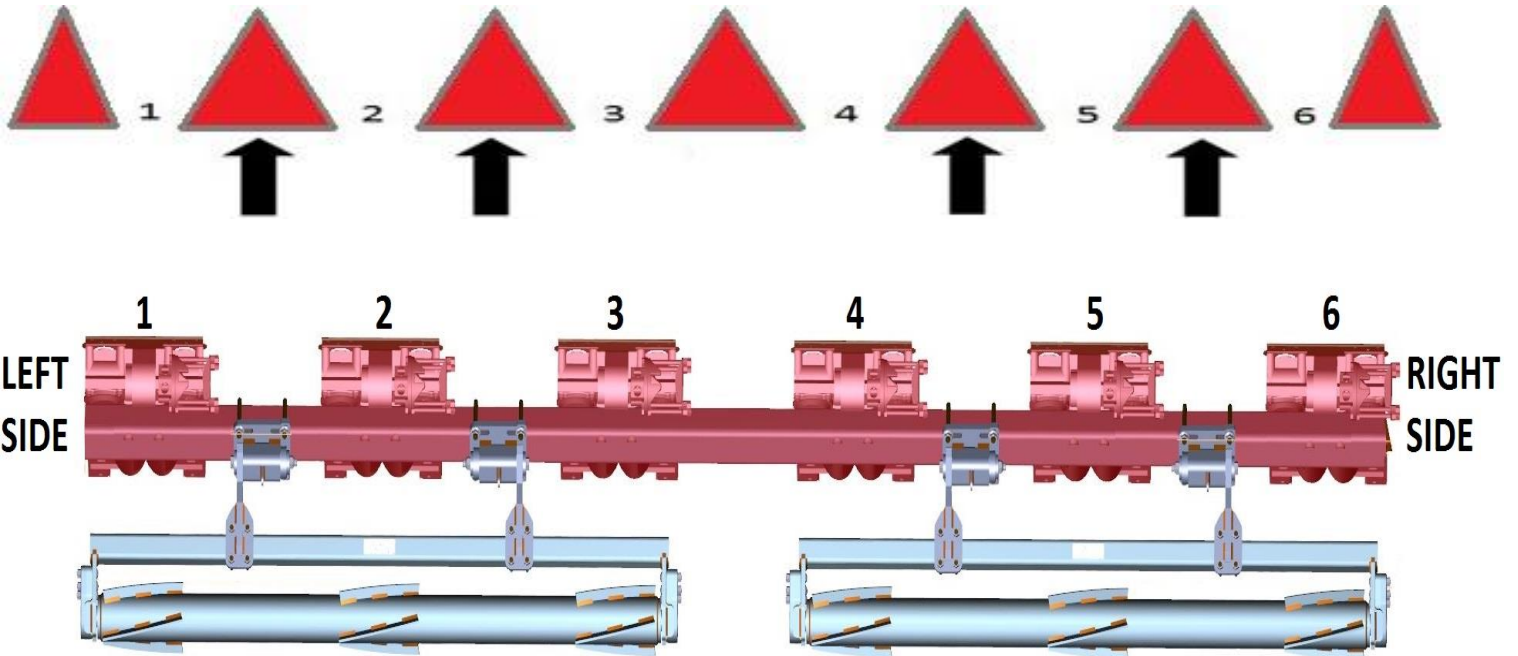

5000-061 8 ROW 30"

Arrows indicate 5000-167 Torsion Pivot locations

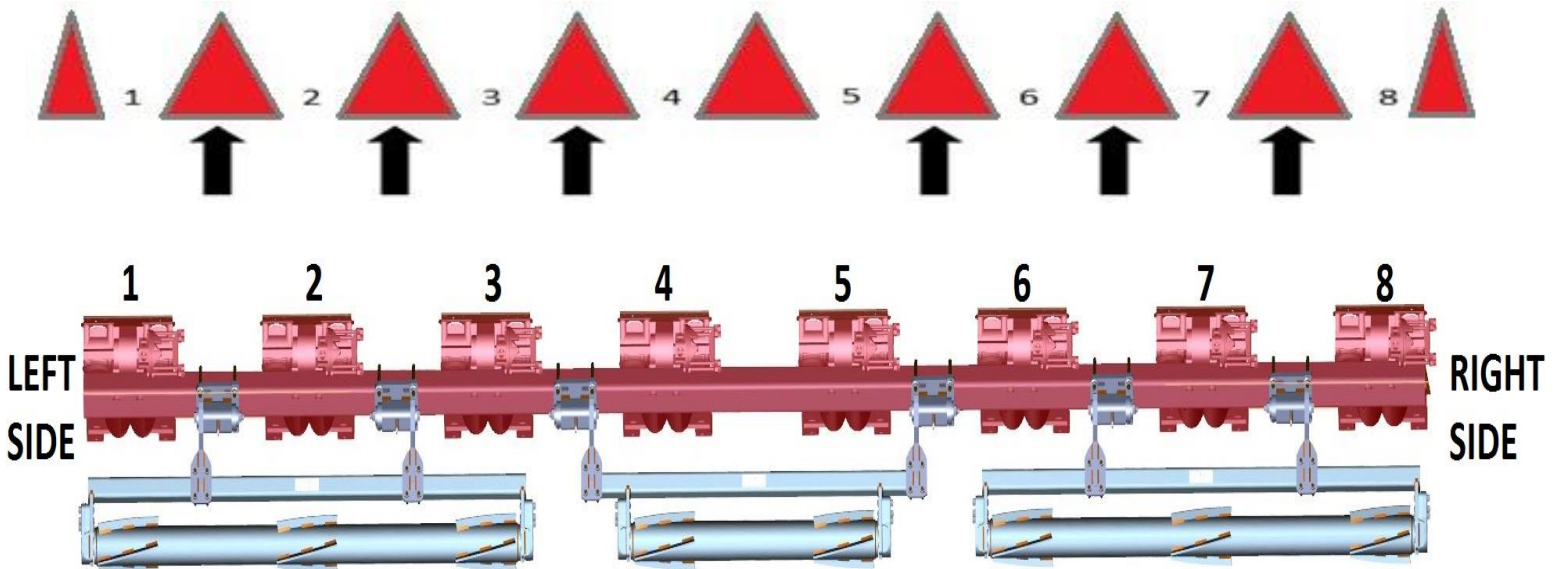

ASSEMBLY INSTRUCTIONS

BELOW ARE RECOMMENDED LOCATIONS OF THE TORSION PIVOT ASSEMBLY, ALTERNATE LOCATIONS MAY BE USED IF INTERFERENCE OCCURS!

5000-062 12 ROW 30"

Arrows indicate 5000-167 Torsion Pivot locations

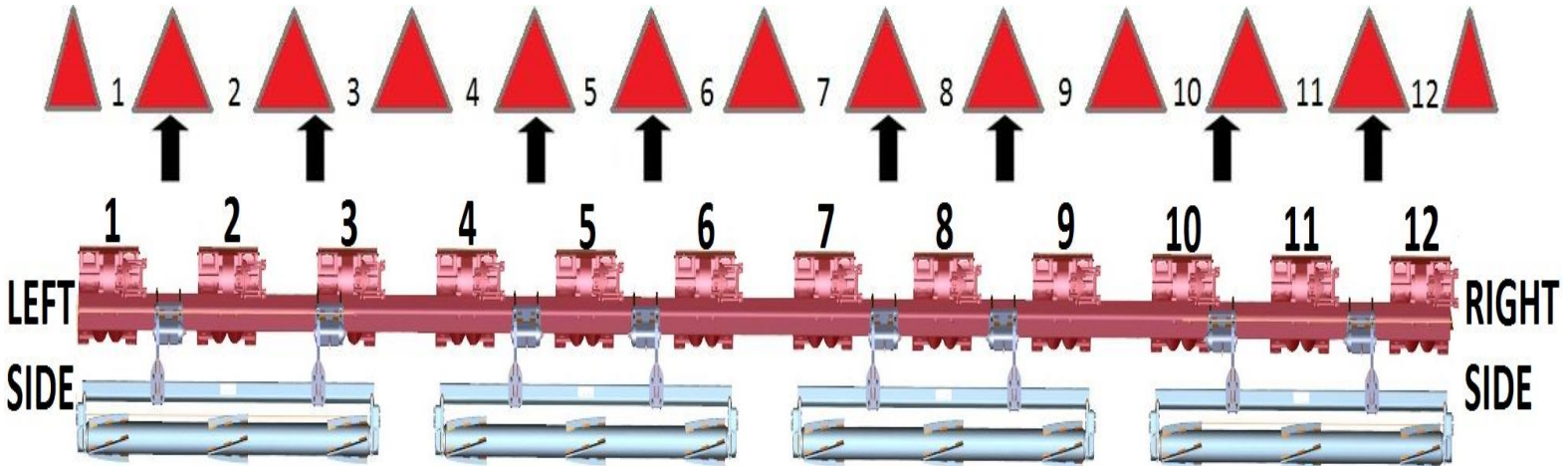

5000-063 12 ROW 20"

Arrows indicate 5000-167 Torsion Pivot locations

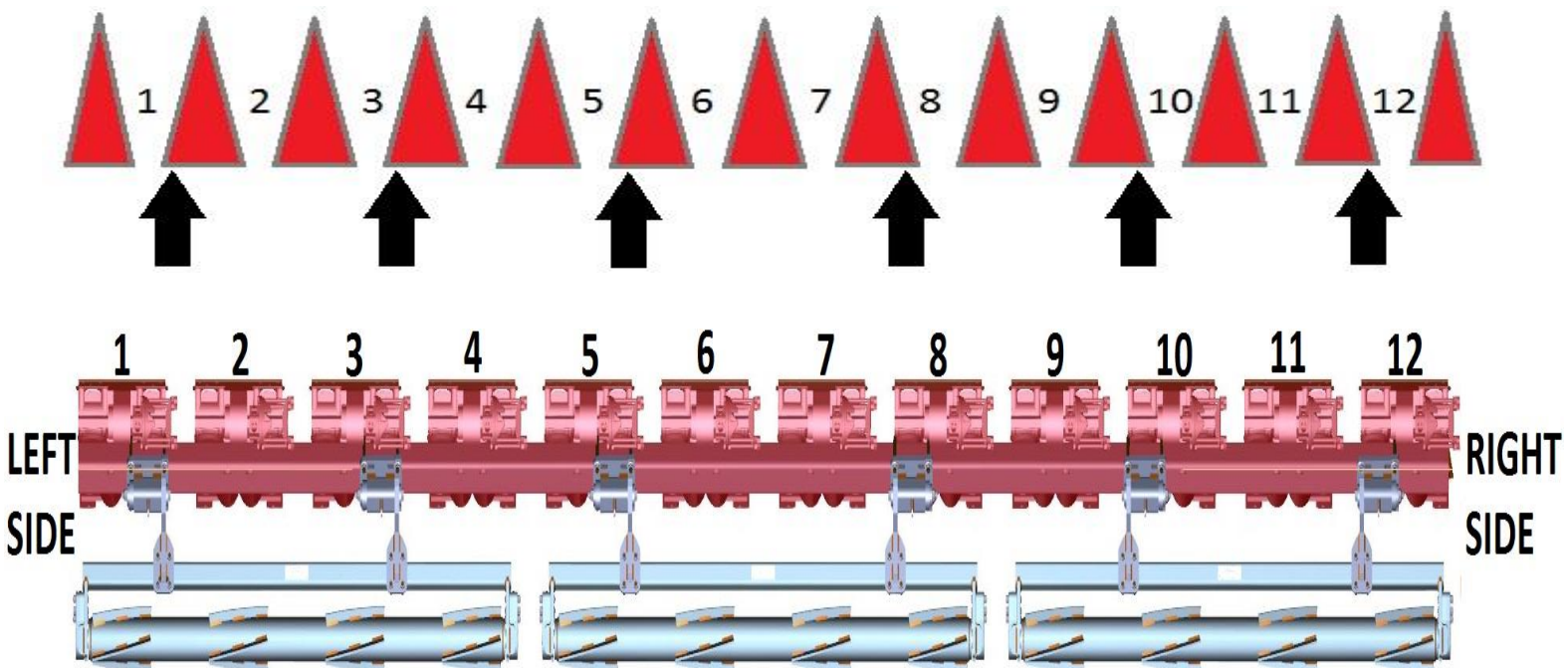

ASSEMBLY INSTRUCTIONS

Step 1: Attach each 5000-167 torsion pivot assembly to the frame using 2) 5/8 X 4 X 5 1/2 U-Bolts & 4) 5/8 – 11 Hex Flange Nuts. See [pages 7 – 8](#) for each torsion pivot assembly mounting location for your corn head.

Note: Torque the 5/8 U-Bolts @ 170 ft. /lbs.

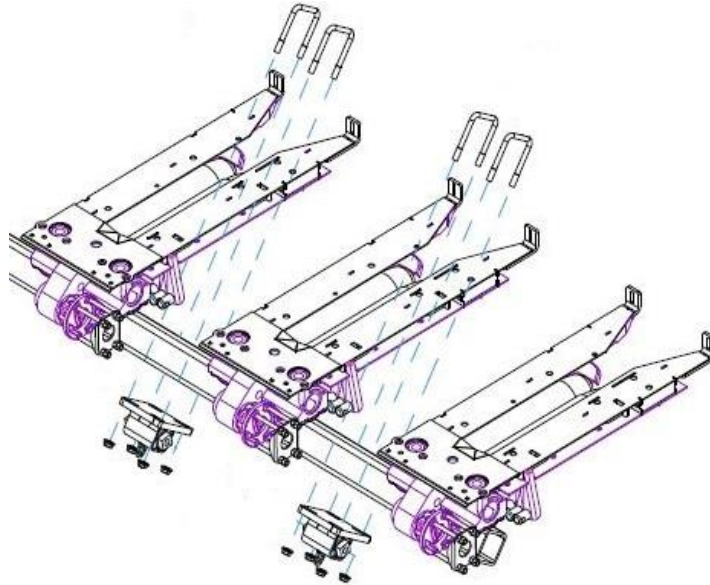

Step 2: Install the 5000-294 Torsion Arm onto the 5000-167 Torsion Pivot Assembly & secure with the 3/4" x 8" bolts & 3/4" lock nuts. Refer to the diagrams on the previous pages to determine which side of the 5000-167 Torsion Pivot Assembly to install the 5000-292 Torsion Arm. See [pages 7-8](#) to determine which side of the torsion arm to mount the torsion pivot to for your corn head.

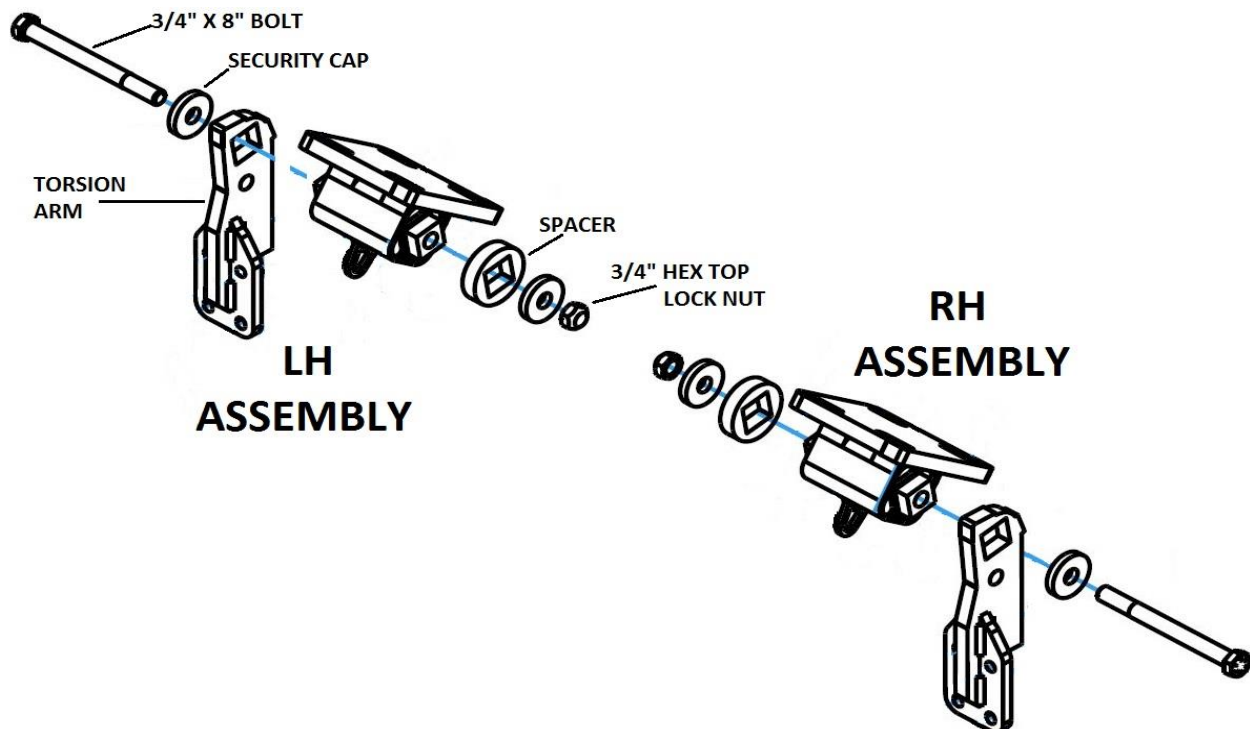

ASSEMBLY INSTRUCTIONS

Step 3: Attach the roller mount to the pivot arms using the 1/2" x 2-1/2" x 3-1/2" U-bolts & lock nuts. See the diagrams on pages 7 – 8 to determine the orientation of the roller & roller mount tube locations for your corn head.

NOTE: The bearing support tab on the roller mount tube should be on the backside of the bearing mount plate.

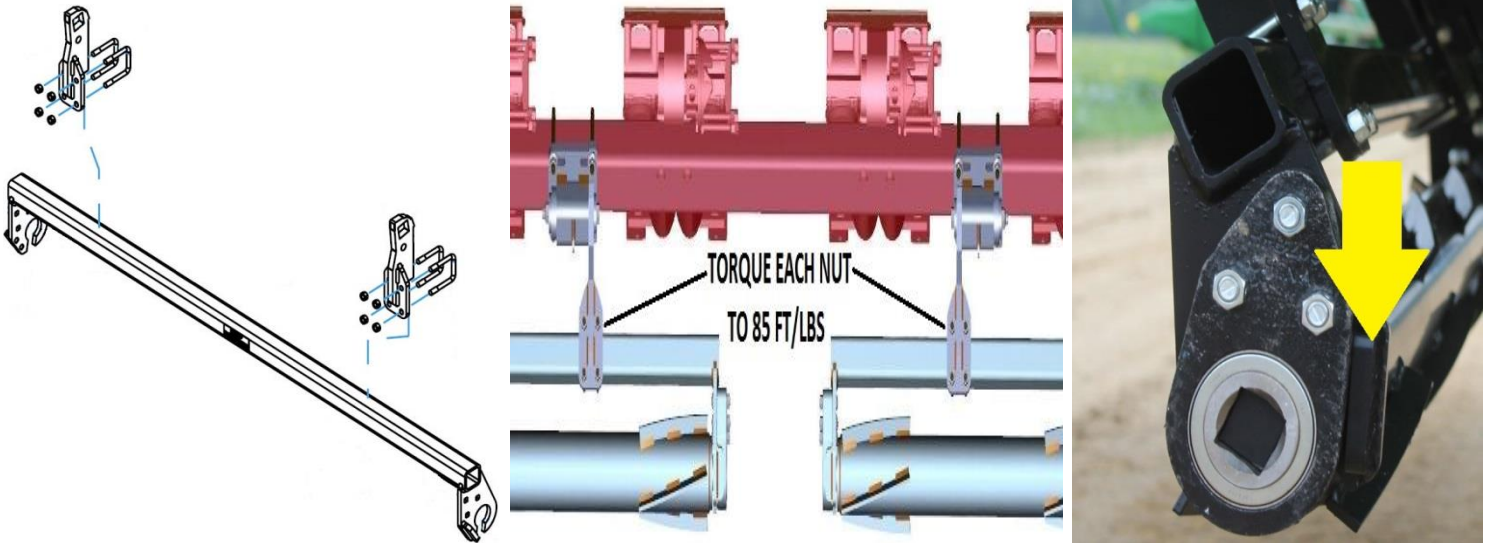

Step 4: Install the Devastator roller, spacer/bushing and bearings to the roller tube using the 1/2" x 2-1/2" carriage bolts. A 3R30 roller is pictured in the diagram below.

IMPORTANT: The spacer must be installed between the roller and the bearing. The notches of the bearing housing must face the mounting plate. The extended race on the bearing will face away from the roller.

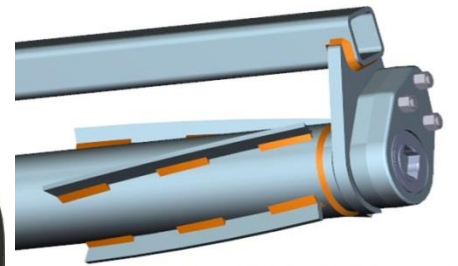
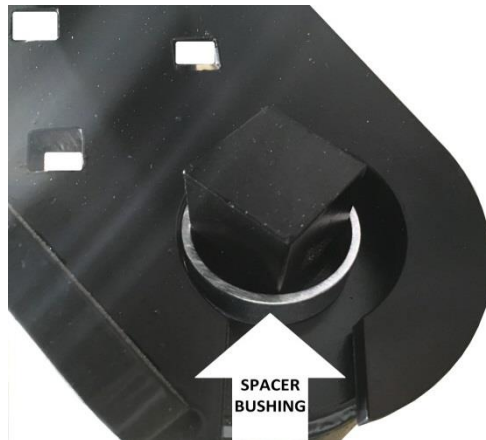
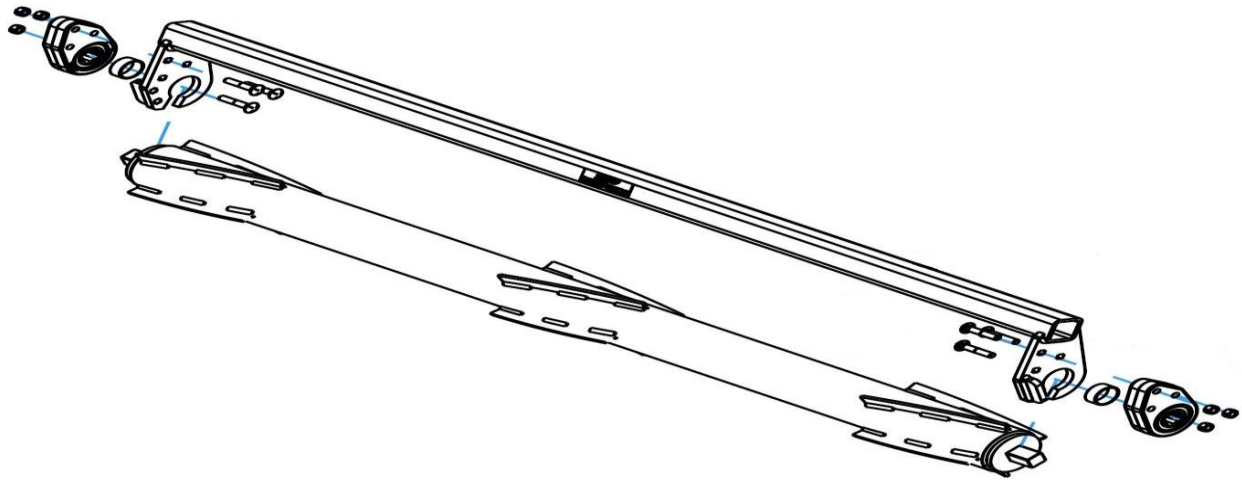

SLIDE THE BEARING OVER THE ROLLER SHAFT MAKING SURE THE RACE OF THE BEARING PROTRUDING OUTSIDE OF THE HOUSING FACES AWAY FROM THE ROLLER.

ASSEMBLY INSTRUCTIONS

Step 5: Slide the roller mount tubes to align the row center with the traction bars. Fully tighten hardware. In some circumstances, the traction bar may have to be off-center of the row some.

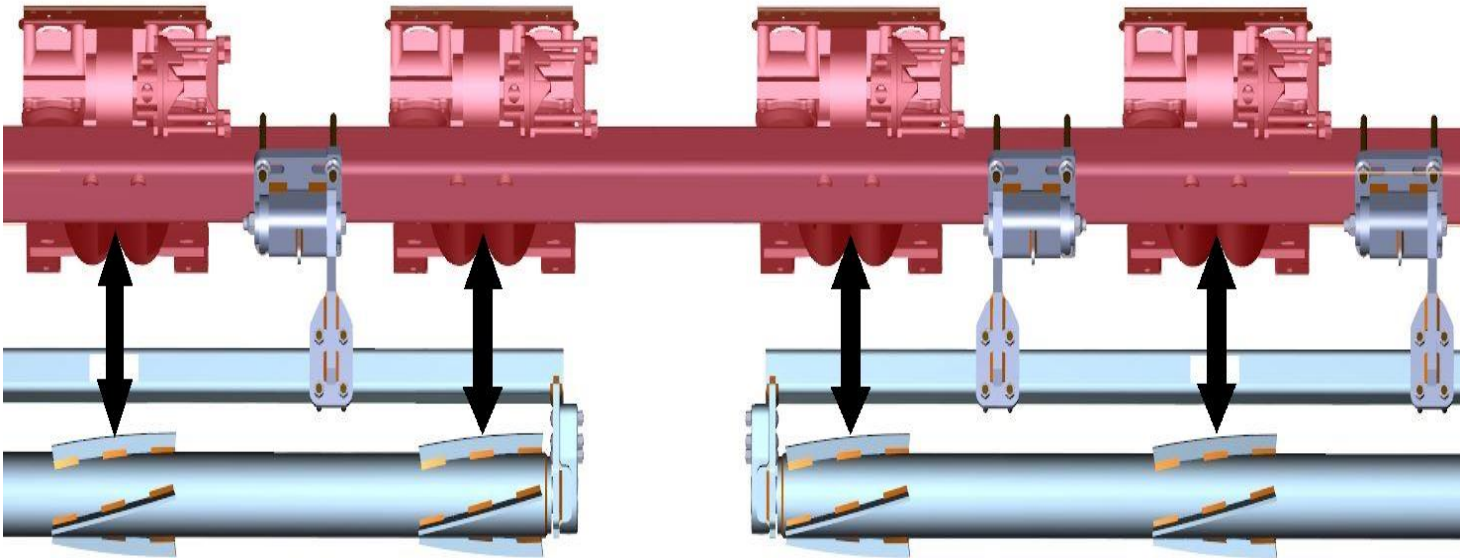

Step 6: (If Applicable) On chopping corn heads, trim 3 inches off the bottom of the back curtain to keep the roller from contacting the curtain.

NOTE: Make sure the chopping blades are sharp enough to size the residue into smaller pieces for better flow between the back curtain & roller mount tube.

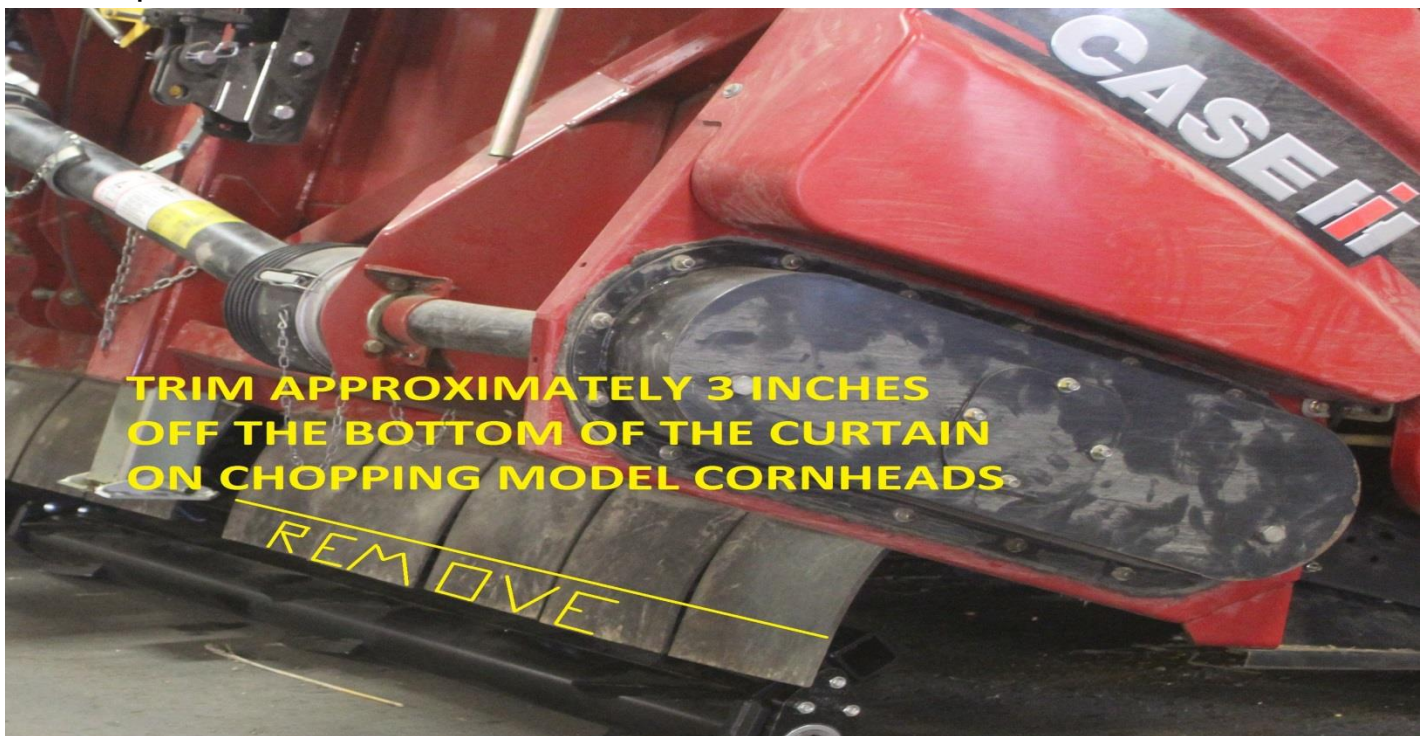

LOCK UP

To “lock up” the Devastator rollers, lower the head down & install a rod through the hole in the mount bracket in front of the pivot arms. A 5000-430 Lock Pin can be ordered separately to lock up the devastator rollers. 6 row heads require 1 lock pin, 8/12 row heads require 2, 18 row heads require 3.

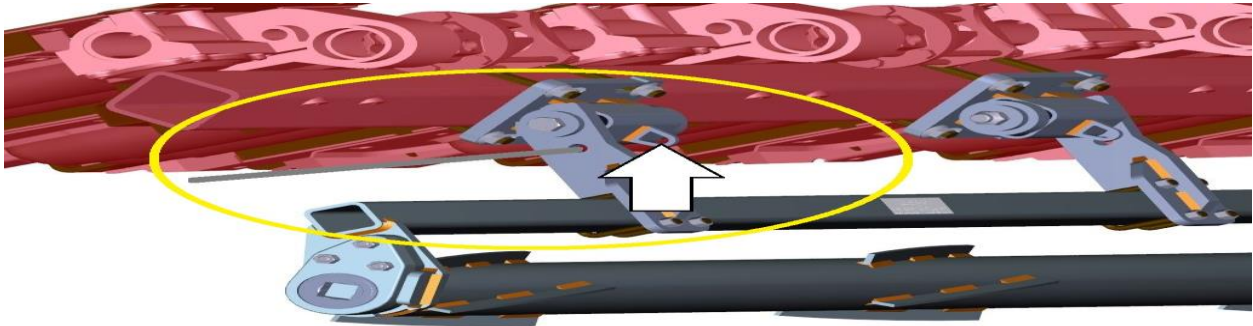

OPERATION

CORN HEAD ANGLE NEEDS TO BE ADJUSTED BETWEEN 23 – 25° FOR OPTIMUM DEVASTATOR PERFORMANCE. USE THE 5000-455 TO CHECK CORN HEAD ANGLE:

- Put the combine on a level surface. Lower the Corn head to your normal working head height.
- Place the magnetic protractor on the stripper plate to get the angle. Adjust the feeder house as needed, fore or aft, to achieve 23 – 25 degrees.



STORAGE/TRANSPORT

- Head cart may need adjusted to fit the head with devastator correctly. E.g., raising the saddles & top rail on the head cart.
- When disconnecting from the head, leaving pressure on the torsion pivot of the devastator will not damage the devastator.

BEARING REPLACEMENT

Put the bearing housing in a vice, use a pry bar to turn the bearing in the housing parallel with the slots, remove the old bearing, apply anti-seize lubricant to the interior of the bearing housing, insert the new bearing in the slots, & use a pry bar to move back to position. Wobble the bearing around to help work the lubricant into the outer race of the bearing.



5000-060 PART IDENTIFICATIONS

CASE 4406 6R30 DEVASTATOR

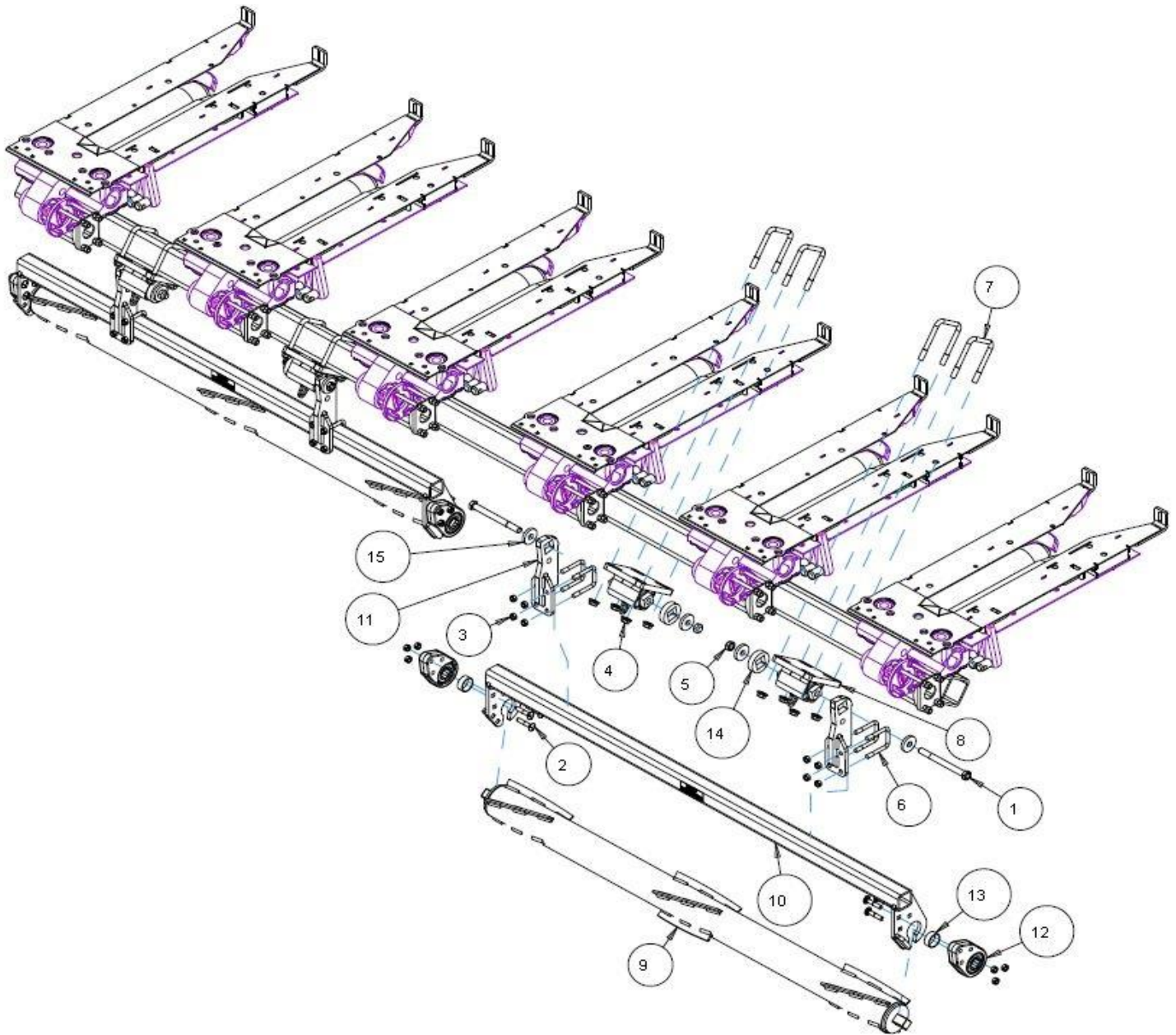

ITEM	PART #	DESCRIPTION	QUANTITY
1	2502-430	3/4 - 10 X 8 HHCS GR 8 ZP	4
2	2505-343	1/2 - 13 X 2 1/2 CARRIAGE BOLT, GR 5, ZP	12
3	2520-357	1/2-13 LOCK HEX NUT, GR A, ZP	28
4	2520-476	5/8 - 11 HEX FLANGE NUT	16
5	2520-604	3/4 - 10 HEX TOP LOCK NUT	4
6	2570-568	1/2 X 2 1/2 X 3 1/2 U-BOLT	8
7	2570-588	5/8 X 4 X 5 1/2 U-BOLT, ZYD	8
8	5000-167	TORSION PIVOT ASSEMBLY	4
9	5000-272	3R30 ROLLER W.A.	2
10	5000-275	4R20/3R30 ROLLER MOUNT W.A.	2
11	5000-292	TORSION ARM W.A.	4
12	5000-355	BEARING ASSEMBLY	4
	2550-059	DEVASTATOR BEARING (NO CAST HOUSING)	4
13	5000-421	ROLLER SPACER BUSHING	4
14	5000-468	SPACER	4
15	5000-469	SECURITY CAP	8

5000-061 PART IDENTIFICATIONS

CASE 4408 8R30 DEVASTATOR

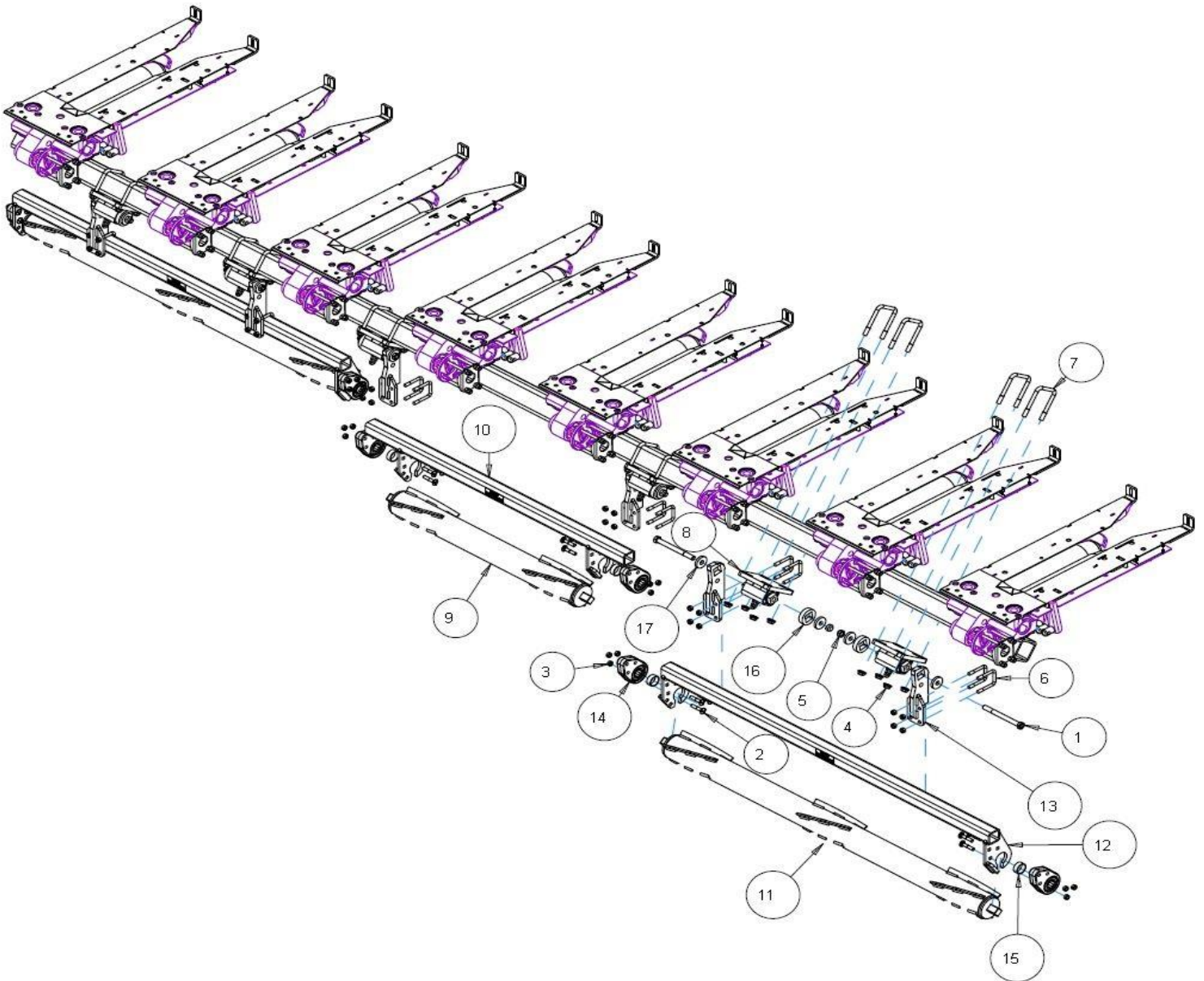

ITEM	PART #	DESCRIPTION	QUANTITY
1	2502-430	3/4 - 10 X 8 HHCS GR 8 ZP	6
2	2505-343	1/2 - 13 X 2 1/2 CARRIAGE BOLT, GR 5, ZP	18
3	2520-357	1/2-13 LOCK HEX NUT, GR A, ZP	42
4	2520-476	5/8 - 11 HEX FLANGE NUT	24
5	2520-604	3/4 - 10 HEX TOP LOCK NUT	6
6	2570-568	1/2 X 2 1/2 X 3 1/2 U-BOLT	12
7	2570-588	5/8 X 4 X 5 1/2 U-BOLT. ZYD	12
8	5000-167	TORSION PIVOT ASSEMBLY	6
9	5000-268	2R30 ROLLER W.A.	1
10	5000-269	2R30 ROLLER MOUNT W.A.	1
11	5000-272	3R30 ROLLER W.A.	2
12	5000-275	4R20/3R30 ROLLER MOUNT W.A.	2
13	5000-294	TORSION ARM W.A.	6
14	5000-355	BEARING ASSEMBLY	6
	2550-059	DEVASTATOR BEARING (NO CAST HOUSING)	6
15	5000-421	ROLLER SPACER BUSHING	6
16	5000-468	SPACER	6
17	5000-469	SECURITY CAP	12

5000-062 PART IDENTIFICATION

CASE 4412 12R30 DEVASTATOR

RH SIDE OF HEAD SHOWN

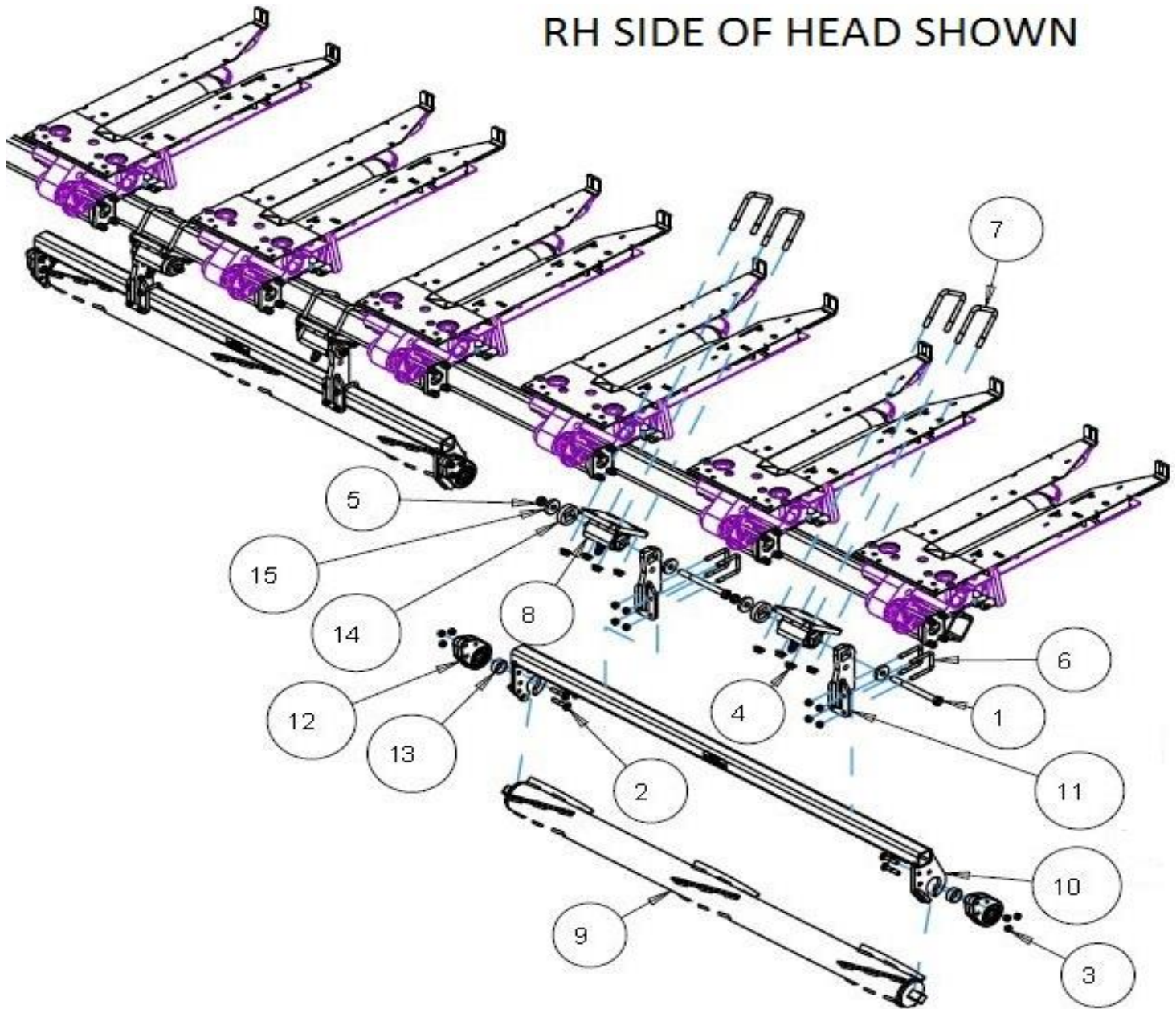

ITEM	PART #	DESCRIPTION	QUANTITY
1	2502-430	3/4 - 10 X 8 HHCS GR 8 ZP	8
2	2505-343	1/2 - 13 X 2 1/2 CARRIAGE BOLT, GR 5, ZP	24
3	2520-357	1/2-13 LOCK HEX NUT, GR A, ZP	56
4	2520-476	5/8 - 11 X HEX FLANGE NUT	32
5	2520-604	3/4 - 10 HEX TOP LOCK NUT	8
6	2570-568	1/2 X 2 1/2 X 3 1/2 U-BOLT	16
7	2570-588	5/8 X 4 X 5 1/2 U-BOLT, ZYD	16
8	5000-167	TORSION PIVOT ASSEMBLY	8
9	5000-272	3R30 ROLLER W.A.	4
10	5000-275	4R20/3R30 ROLLER MOUNT W.A.	4
11	5000-294	TORSION ARM W.A.	8
12	5000-355	BEARING ASSEMBLY	8
	2550-059	DEVASTATOR BEARING (NO CAST HOUSING)	8
13	5000-421	ROLLER SPACER BUSHING	8
14	5000-468	SPACER	8
15	5000-469	SECURITY CAP	16

5000-063 PART IDENTIFICATION

CASE 4412 12R20 DEVASTATOR

CENTER 4 ROWS SHOWN

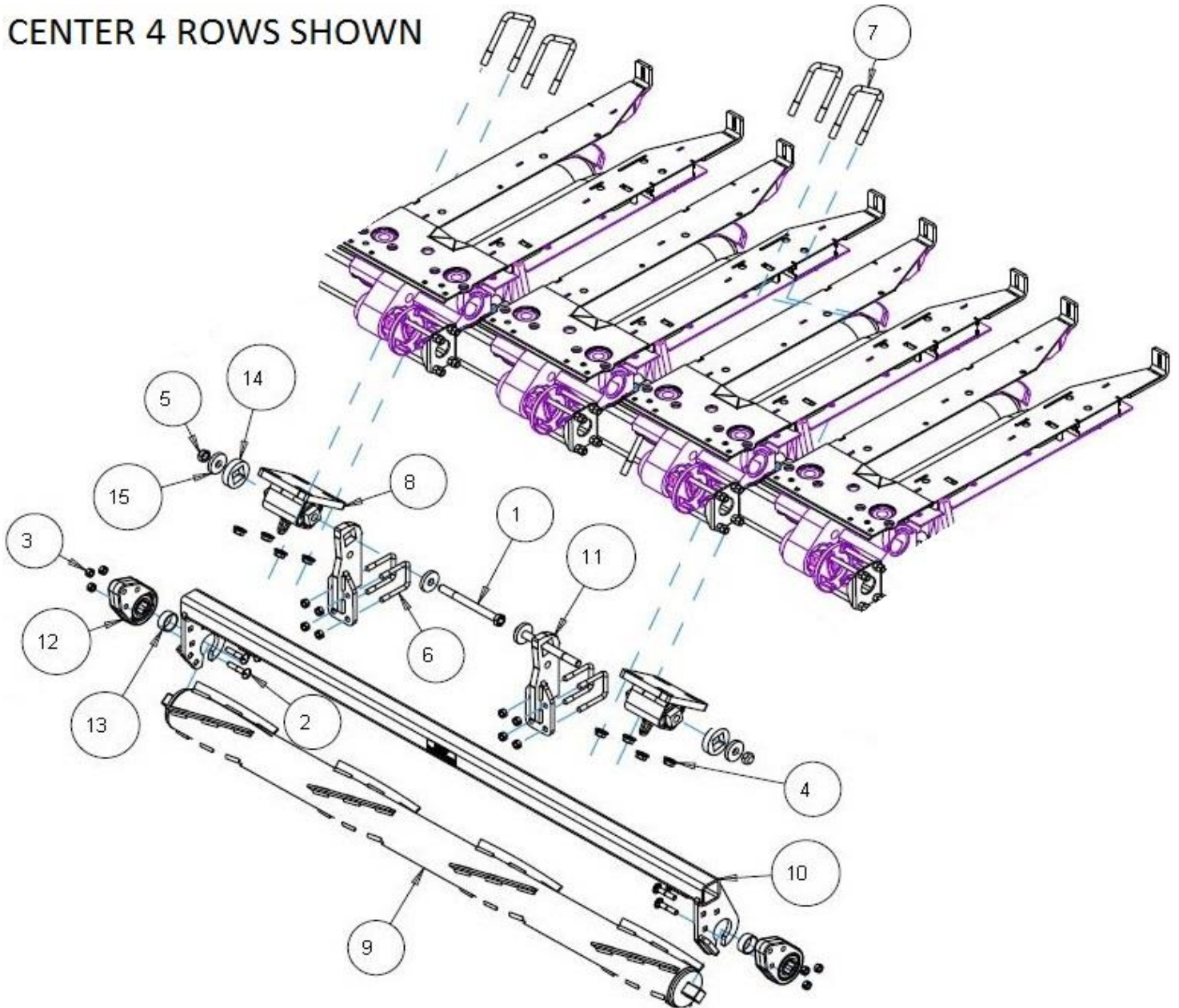

ITEM	PART #	DESCRIPTION	QUANTITY
1	2502-430	3/4 - 10 X 8 HHCS GR 8 ZP	6
2	2505-343	1/2 - 13 X 2 1/2 CARRIAGE BOLT, GR 5, ZP	18
3	2520-357	1/2-13 LOCK HEX NUT, GR A, ZP	42
4	2520-476	5/8 - 11 X HEX FLANGE NUT	24
5	2520-604	3/4 - 10 HEX TOP LOCK NUT	6
6	2570-568	1/2 X 2 1/2 X 3 1/2 U-BOLT	12
7	2570-588	5/8 X 4 X 5 1/2 U-BOLT, ZYD	12
8	5000-167	TORSION PIVOT ASSEMBLY	6
9	5000-267	4R20 ROLLER W.A.	3
10	5000-275	4R20/3R30 ROLLER MOUNT W.A.	3
11	5000-294	TORSION ARM W.A.	6
12	5000-355	BEARING ASSEMBLY	6
	2550-059	DEVASTATOR BEARING (NO CAST HOUSING)	6
13	5000-421	ROLLER SPACER BUSHING	6
14	5000-468	SPACER	6
15	5000-469	SECURITY CAP	12

TROUBLESHOOTING

ISSUE	CAUSE	CORRECTIVE ACTION
Residue Plugging	<ol style="list-style-type: none"> 1. Incorrect Head Angle 2. Roller Mount Tube incorrectly installed 3. Pivot arm orientation incorrect 4. Bearing installed incorrectly 	<ol style="list-style-type: none"> 1. Adjust head angle to 23 – 25 degrees (see page 12) 2. Make sure the Bearing Support Tab is on the backside of the Roller Mount Tube 3. Reposition the pivot arm so that it offsets under the snout & not under the row 4. Make sure the side of the bearing that protrudes outside of the cast housing is facing AWAY from the roller (each roller should spin freely by hand)
Stalk aren't "devastated"	<ol style="list-style-type: none"> 1. Operating corn head too high 	<ol style="list-style-type: none"> 1. Lower corn head until the rollers engage
Corn Head won't fit on head cart	<ol style="list-style-type: none"> 1. Devastators bottom out 2. Storage stands don't rest in the saddles on the cart 	<ol style="list-style-type: none"> 1. Adjust top rail & saddles higher on cart 2. Make Stand Extensions for Saddle Extensions for head cart





NOTES



A Tradition of Solutions since 1930

Yetter Farm Equipment Co

PO BOX 358 109 S. McDonough

Colchester, IL 62326-0358

Phone: 309-776-4111

Toll Free: 800-447-5777

Email: info@yetterco.com

For updated models and manuals visit the Yetter website:

www.yetterco.com

© Yetter Farm Equipment Co. All Rights Reserved

2565-970 – 08/2019