



**5000 SERIES  
STALK DEVASTATOR  
CORN STALK ROLLER  
\*PATENTED\***

**5000-025A, 5000-026A, 5000-027A, 5000-028A, 5000-034A  
John Deere Model Corn Heads (606C, 643, 693, 706C, 608C, 843,  
893, 708C, 612C, 612FC Folding, 712C, 1243, 1293, 616C, & 716C)**

**OWNER'S MANUAL  
PART IDENTIFICATION  
2565-785\_Rev\_D – 12/2018**



**YETTER MANUFACTURING CO.**

Founded 1930

Colchester, IL 62326

Toll free: (800)447-5777.

Fax: (309)776-3222

Website: yetterco.com

E-mail: info@yetterco.com

**YETTER**

# Table of Contents

<b>Foreword</b> .....	<b>3</b>
<b>Warranty</b> .....	<b>3</b>
<b>Safety Information</b> .....	<b>4 - 6</b>
<b>Pictorial Part List</b> .....	<b>7 - 9</b>
<b>Bolt Torque &amp; Tools Required</b> .....	<b>10</b>
<b>Assembly Instructions</b> .....	<b>11 - 36</b>
5000-025A .....	11 - 15
5000-026A .....	16 - 20
5000-027A .....	21 - 25
5000-028A .....	26 - 31
5000-034 .....	32 - 36
<b>Operation / Maintenance / Lock Up</b> .....	<b>37</b>
<b>Part Identification</b> .....	<b>38 - 48</b>
<b>Troubleshooting</b> .....	<b>51</b>



## FOREWORD

You've just joined an exclusive but rapidly growing club.

For our part, we want to welcome you to the group and thank you for buying a Yetter product.

We hope your new Yetter products will help you achieve both goals-increase your productivity and increase your efficiency so that you may generate more profit.

This operator's manual has been designed into four major sections: Foreword, Safety Precautions, Installation Instructions and Parts Breakdown.



This **SAFETY ALERT SYMBOL** indicates important safety messages in the manual. When you see this symbol, be alert to the possibility of **PERSONAL INJURY** and carefully read the message that follows.

The word **NOTE** is used to convey information that is out of context with the manual text. It contains special information such as specifications, techniques and reference information of a supplementary nature.

The word **IMPORTANT** is used in the text when immediate damage will occur to the machine due to improper technique or operation.

Important will apply to the same information as specified by note only of an immediate and urgent nature.

It is the responsibility of the user to read the operator's manual and comply with the safe and correct operating procedure and to lubricate and maintain the product according to the maintenance schedule in the operator's manual.

The user is responsible for inspecting his machine and for having parts repaired or replaced when continued use of the product would cause damage or excessive wear to the other parts.

It is the user's responsibility to deliver his machine to the Yetter dealer who sold him the product for service or replacement of defective parts, which are covered by the warranty policy.

If you are unable to understand or follow the instructions provided in this publication, consult your local Yetter dealer or contact:

### **YETTER MANUFACTURING CO.**

309/776-4111

800/447-5777

309/776-3222 (FAX)

Website: [www.yetterco.com](http://www.yetterco.com)

E-mail: [info@yetterco.com](mailto:info@yetterco.com)

## WARRANTY

Yetter Manufacturing warrants all products manufactured and sold by it against defects in material. This warranty being expressly limited to replacement at the factory of such parts or products as shall appear to be defective after inspection. This warranty does not obligate the Company to bear cost of labor in replacement of parts. It is the policy of the Company to make improvements without incurring obligations to add them to any unit already sold. No warranty is made or authorized to be made, other than herein set forth. This warranty is in effect for one year after purchase.

DEALER: \_\_\_\_\_

**Yetter Manufacturing warrants its own products only and cannot be responsible for damages to equipment on which mounted.**

# **BE ALERT!**

## **YOUR SAFETY IS INVOLVED**



**WATCH FOR THIS SYMBOL. IT POINTS OUT IMPORTANT SAFETY PRECAUTIONS. IT MEANS “ATTENTION – BE ALERT!”**

It is your responsibility as an owner, operator, or supervision to know and instruct everyone using this machine at the time of initial assignment and at least annually thereafter, of the proper operation, precautions, and work hazards which exist in the operation of the machine in accordance with OSHA regulations.

### **Safety Is No Accident**

**The following safety instructions, combined with common sense, will save your equipment from needless damage and the operator from unnecessary exposure to personal hazard. Pay special attention to the caution notes in the text. Review this manual at least once a year with all operators.**



1. Read and understand the operator's manual before operating this machine. Failure to do so is considered a misuse of the equipment.
2. Make sure equipment is secure before operating.
3. Always keep children away from equipment when operating.
4. Make sure everyone that is not directly involved with the operation is out of the work area before beginning operation.
5. Make sure all safety devices, shields, and guards are in place and functional before beginning operation
6. Shut off all power to adjust, service, or clean.
7. Keep hands, feet, and clothing away from moving parts. It is a good idea to remove all jewelry before operating.
8. Inspect the machine periodically during operation for signs of excessive wear, loose fasteners, and unusual noises.

# PLEASE READ, VERY IMPORTANT



**SECURE CORN HEADER AGAINST UNWANTED LOWERING BY APPLYING THE LOCKING MECHANISM ON THE HYDRAULIC CYLINDERS!**



1. Attach head to combine, lock head to combine
2. Raise the head off the ground and engage safety stop on the feeder house cylinder.
3. Apply combine parking brake, turn off combine engine, and remove the key
4. Wear personal protective equipment during installation: steel toe footwear, safety glasses, & gloves

**FOLLOW ALL INSTRUCTIONS GIVEN BY THE COMBINE MANUFACTURER**

# **PLEASE READ, VERY IMPORTANT**



**Subject to the size and weight of the corn header, one or two additional hydraulic cylinders may be required.**

**The combine manufacturer generally keeps corresponding kits readily available for dealers.**

**Subject to the design of the corn header and the carrying capacity of different combines, the steering axle may require the fitting of additional weights and the rear tires be filled with ballast.**

**FOLLOW ALL INSTRUCTIONS GIVEN BY THE COMBINE  
MANUFACTURER**



# PICTORIAL PART LIST



## **BEFORE INSTALLATION BEGINS, PLEASE CHECK THAT ALL PARTS WERE RECEIVED BY GOING THROUGH THE CRATE AND SORTING THE PARTS!!!**

**5000-025A for JD 606C, 643, 693, 706C, (wheel tracks only) 612C, 712, 1243, 1293, 616C, & 716 Parts List**  
 4) 5000-136, 4) 5000-138, 4) 5000-139, 4) 5000-202, 1) 5000-211A, 1) 5000-212A, 2) 5000-254, 2) 5000-256, 2) 5000-259, 4) 5000-355

**5000-026A for JD 608C, 708C, 843, & 893 Parts List** – 6) 5000-136, 6) 5000-138, 6) 5000-139, 6) 5000-202, 1) 5000-203A, 1) 5000-211A, 1) 5000-212A, 2) 5000-254, 1) 5000-255, 3) 5000-256, 3) 5000-259, 2) 5000-301, 6) 5000-355

**5000-027A for JD 612C, 712C, 1243, & 1293 Parts List** – 8) 5000-136, 8) 5000-138, 8) 5000-139, 8) 5000-202, 2) 5000-211A, 2) 5000-212A, 4) 5000-254, 4) 5000-256, 4) 5000-259, 2) 5000-301, 8) 5000-355

**5000-028A for JD 616C & 716C Parts List** – 12) 5000-136, 12) 5000-138, 12) 5000-139, 12) 5000-202, 2) 5000-203, 2) 5000-211A, 2) 5000-212A, 4) 5000-254, 2) 5000-255, 6) 5000-256, 6) 5000-259, 12) 5000-355

**5000-034 for JD 612FC & 712FC Folding Parts List** – 8) 5000-136, 8) 5000-138, 8) 5000-139, 1) 5000-141, 4) 5000-202, 2) 5000-211A, 2) 5000-212A, 4) 5000-254, 4) 5000-256, 4) 5000-259, 4) 5000-263, 8) 5000-355

**5000-080 – 5” Extension Kit Parts List (Optional)** – 2) 2502-363 – ½” X 4 ½” GR 5 Bolts, 2) 2502-365 – ½”-13 X 3 ¾” GR 5 Bolts, 6) 2520-357 – ½” Lock Nuts, 2) 5000-378 Spacer Bushings, 2) 5000-393 5” Extension Plates, & 2) 5000-394 Short Spacers

**5000-082 – 2” Lift Kit Parts List (Optional)** – 2) 5000-408 Extender Plate, 1) 5000-409 Connector Pin

**5000-083 – 6 Row Devastator Lock Up Kit (Optional)** – 1) 5000-161 Hardware Bag, 1) 5000-430 Lock Pin

**5000-084 – 8/12 Row Devastator Lock Up Kit (Optional)** – 1) 5000-162 Hardware Bag, 2) 5000-430 Lock Pin

# PICTORIAL PART LIST

## 5000-136 Hardware Bag



← 2502-325 - 5/8-11 X 3 HHCS GR 5 ZP – QTY 1

2502-353 – 1/2-13 x 2 1/2, HHCS, GR8, ZP – QTY 3 →

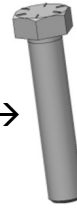

← 2510-121 - 5/8 DIA. SHLDR, 2-1/4 L SHLDR, 1/2-13 QTY 1

2520-357 - 1/2-13 LOCK HEX NUT, GR A, ZP – QTY 3 →

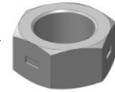

← 2520-364 - 1/2-13 HEX LOCKNUT, JAM, GR 2 – QTY 1

2520-459 - 5/8-11 LOCK HEX NUT, GR 5, ZP – QTY 1 →

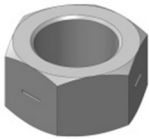
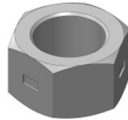

← 2520-515 - 3/4-10 LOCK HEX NUT, GR A, ZP – QTY 1

2526-449 - 5/8 FLATWASHER 1/4+ .010 THK, ZP – QTY 2 →



← 2550-709 - 1/2 WIRE 2-1/2 OD X 1-1/2 ID X 7-1/4 COMP SPRING – QTY 1

2570-126 - 3/4 X 10 EYEBOLT, ZP – QTY 1 →

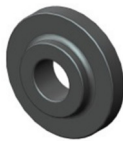

← 2975-302 - 2975 SPRING BUSHING, PAINTED – QTY 1

5000-318 - PIVOT BUSHING – QTY 1 →

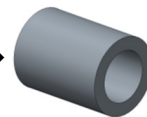

← 5000-322 - SHIM WASHER ZP – QTY 1



# PICTORIAL PART LIST

## 5000-138 Hardware Bag

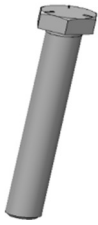

← 2502-365 - 1/2-13 X 3-3/4 HHCS GR5 YD – QTY 2

2520-357 - 1/2-13 LOCK HEX NUT, GR A, ZP – QTY 2 →

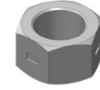

← 5000-378 - SPACER BUSHING – QTY 2

## 5000-139 Hardware Bag



← 2502-352 - 5/8-11 X 6 HHCS GRADE 8 ZP – QTY 4

2505-345 - 1/2-13 X 2 CAR BLT GR5 ZP – QTY 2 →

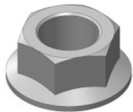

← 2520-361 - 1/2-13 FLANGE WHZLCK HXNT, GR 5, ZP - QTY 2

2520-459 - 5/8-11 LOCK HEX NUT, GR A, ZP – QTY 4 →

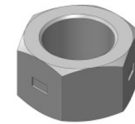

← 2570-465 - 7 GA. HAIRPIN COTTER ZP – QTY 2

5000-309 - SUPPORT STRAP – QTY 2 →



← 5000-319 - MOUNT STRAP 3" – QTY 2

5000-323 - LOCK UP PIN ZP – QTY 1 →



## 5000-141 Hardware Bag



← 2505-414 – 5/8 – 11 X 6 CARRIAGE BOLT, GR 5 ZP – QTY 2

5000-402 – WEDGE – QTY 2 →



# BOLT TORQUE



**Important:** Over-tightening hardware can cause just as much damage as under-tightening. Tightening hardware beyond the recommended range can reduce its shock load capacity.





All hardware on the 5000 Devastator is either Grade 5 or Grade 8, unless otherwise noted. Grade 5 cap screws are marked with three radial lines on the head. Grade 8 cap screws are marked with six radial lines on the head. If hardware must be replaced, be sure to replace it with hardware of equal size, strength and thread type. Refer to the torque values chart when tightening hardware.

The chart below is a guide for proper torque. Use it unless a specified torque is called out elsewhere in the manual.

Torque is the force applied to the end of the handle or cheater bar, times the length of the handle or bar.

## Use a torque wrench wherever possible

The following table shows torque in ft.-lbs. for coarse thread hardware.

Bolt Diameter and Threads per Inch	 Grade 2	 Grade 5	 A-325	 Grade 8
1/4	6	10		14
5/16	12	20		30
3/8 – 16	25	35		50
7/16 – 14	35	55		80
1/2 – 13	55	85		125
9/16 – 12	75	125		175
5/8 – 11	105	170		235
3/4-10	185	305		425
7/8 – 9	170	445		690
1-8	260	670		1030
1 1/8 – 7	365	900		1460
1 1/4 - 7	515	1275		2060
1 3/8 – 6	675	1675		2700
1 1/2 - 6	900	2150		3500
1 3/4 – 5	1410	3500		5600

## INSTALLATION TOOLS REQUIRED:

- Pneumatic or electric impact driver
- 3/4 & 15/16 size sockets
- 10" impact driver extension
- Ratchet
- 3/4, 15/16, & 1 1/8 size wrenches
- 5/16 Allen Wrench
- Torque Wrench



# 5000-025A ASSEMBLY INSTRUCTIONS

(606C, 643, 693, 706C or Wheel Track only on 12 & 16 row JD corn heads)

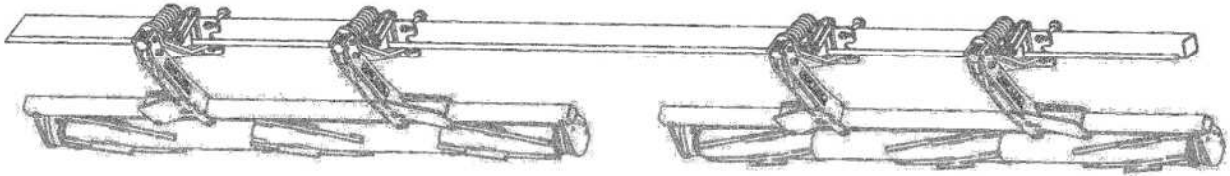

**Step 1:** Attach the 5000-202 mount brackets to the frame using the 5/8 x 6 bolts, mounting straps, and 5/8" lock hex nuts. Mounting Brackets will be located under the snouts between rows 1 & 2, 2 & 3, 4 & 5, and 5 & 6. Slide the mount bracket up so the deck plate adjustment rod is located in the cut out of the mount bracket. . If corn head is equipped with protective shield (like pic with the arrow shows), you can either: remove each shield, cut a notch in each shield, or bend each shield upwards to gain clearance. The shields on a 90 series head will need removed.

**Note:** Do not fully tighten hardware until **Step 6** after all of the pivot arms & springs are installed.

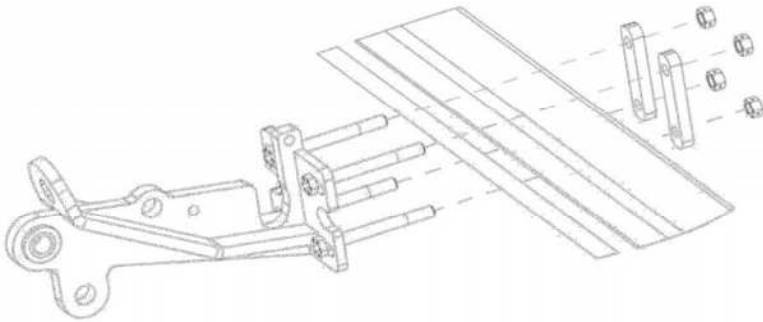

## 6 Row

Arrows indicate 5000-202 mount bracket locations

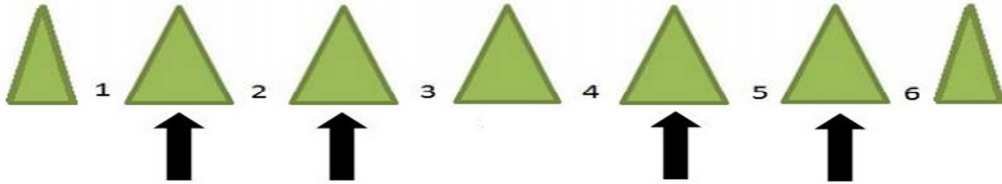

## 12 Row Wheel Tracks

Arrows indicate 5000-202 mount bracket locations (rows 3/4 & 4/5 and 8/9 & 9/10 could also be used)

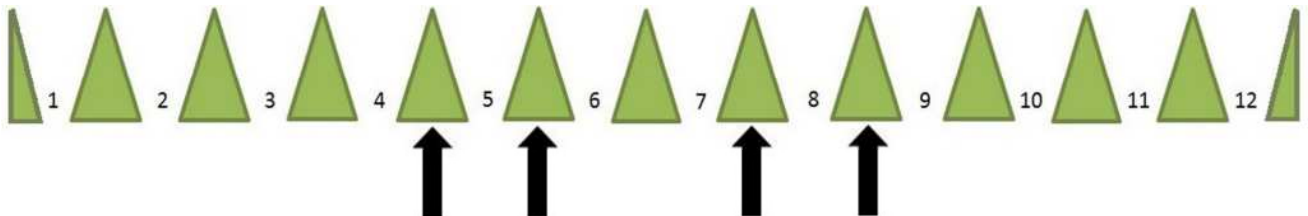

## 16 Row Wheel Tracks

Arrows indicate 5000-202 mount bracket locations (rows 5/6 & 6/7 and 9/10 & 10/11 could also be used)

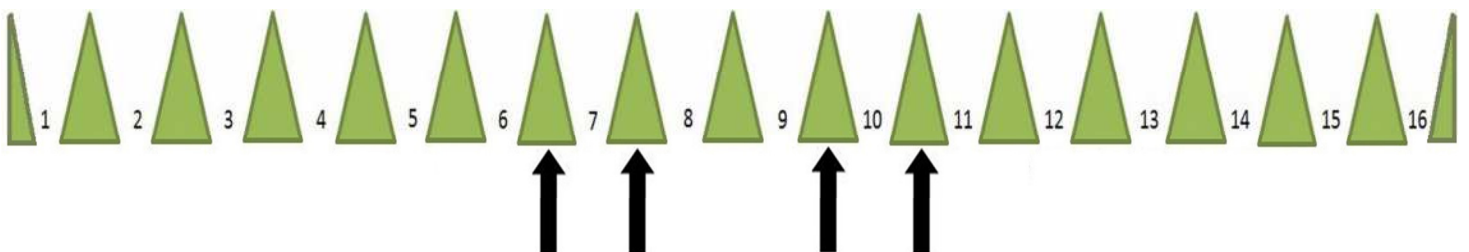

# 5000-025A ASSEMBLY INSTRUCTIONS

**Step 2:** Attach the 5000-309 support straps using 1/2" x 2 carriage bolts & 1/2" flange lock nuts, tighten.

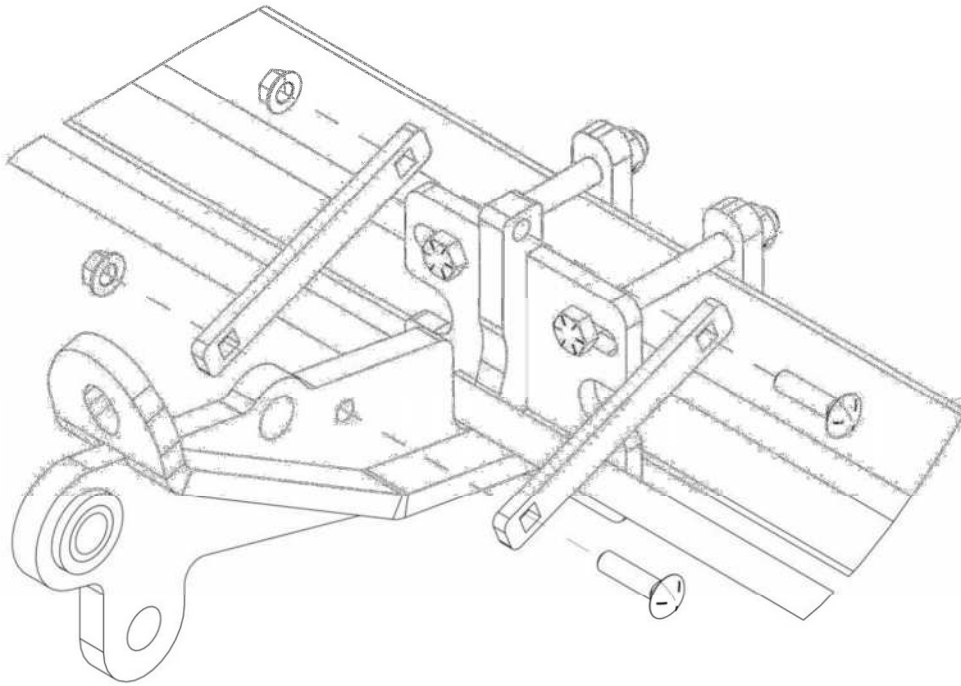

**Step 3:** Install the 5000-323 lock-up pin in the storage location on the mount brackets. Secure with the hairpin clips.

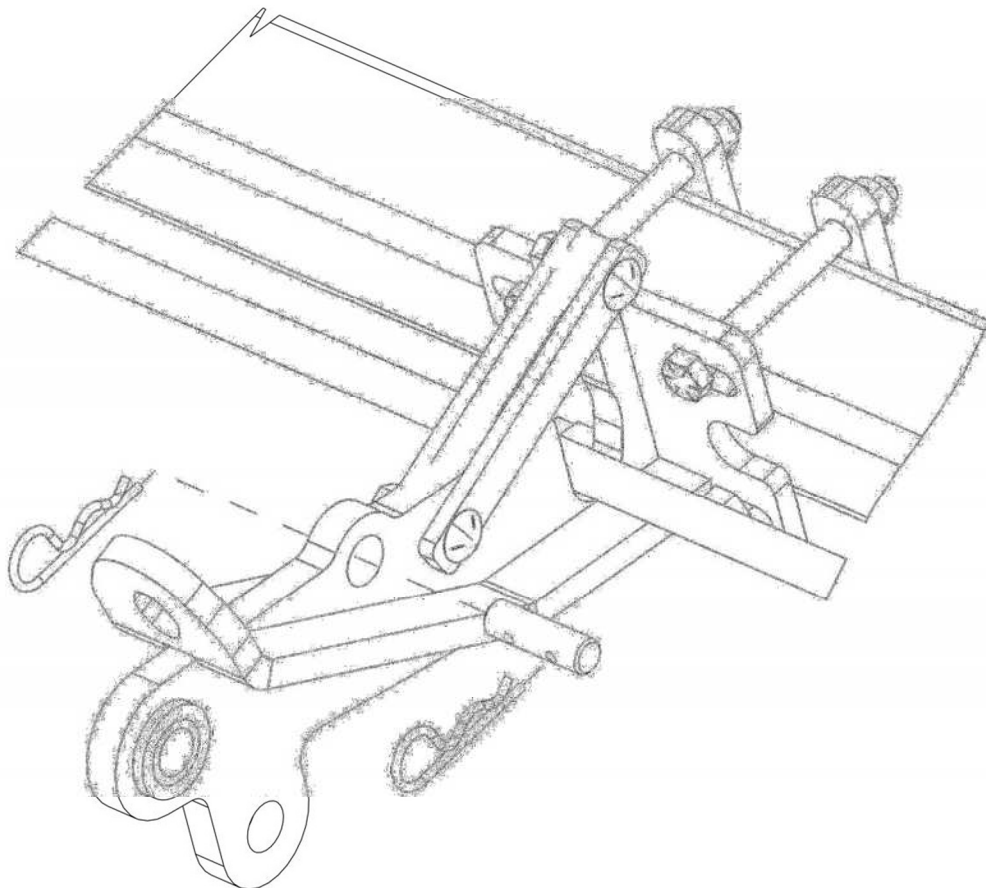

# 5000-025A ASSEMBLY INSTRUCTIONS

**Step 4:** Attach the pivot arms to the mount brackets using 5/8" X 3" bolts, pivot bushings, & lock hex nuts. Use the model below to determine where the LH & RH pivot arms get installed. Tighten this hardware.

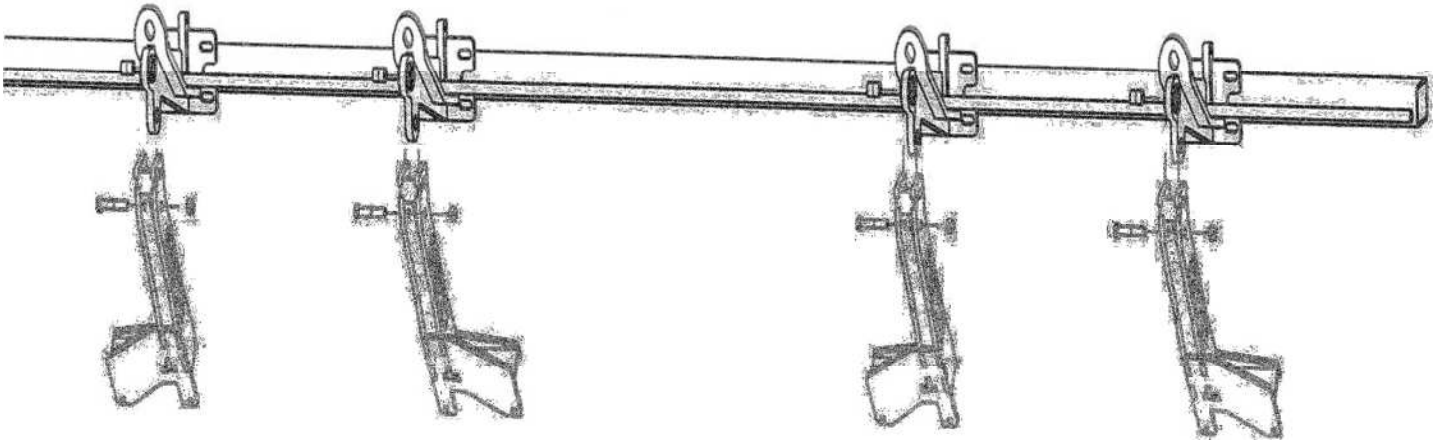

**Step 5:** Install the push rods into the mount brackets then attach to the pivot arms with the 5/8" shoulder bolts, washers, and 1/2" jam lock nuts.

**Note:** The washers are installed on each side of the "eye" of the push rod.

Now install the compression spring, spring bushing, and 3/4" lock hex nuts. Tighten the hardware from **Step 5** to the specification in the diagram below.

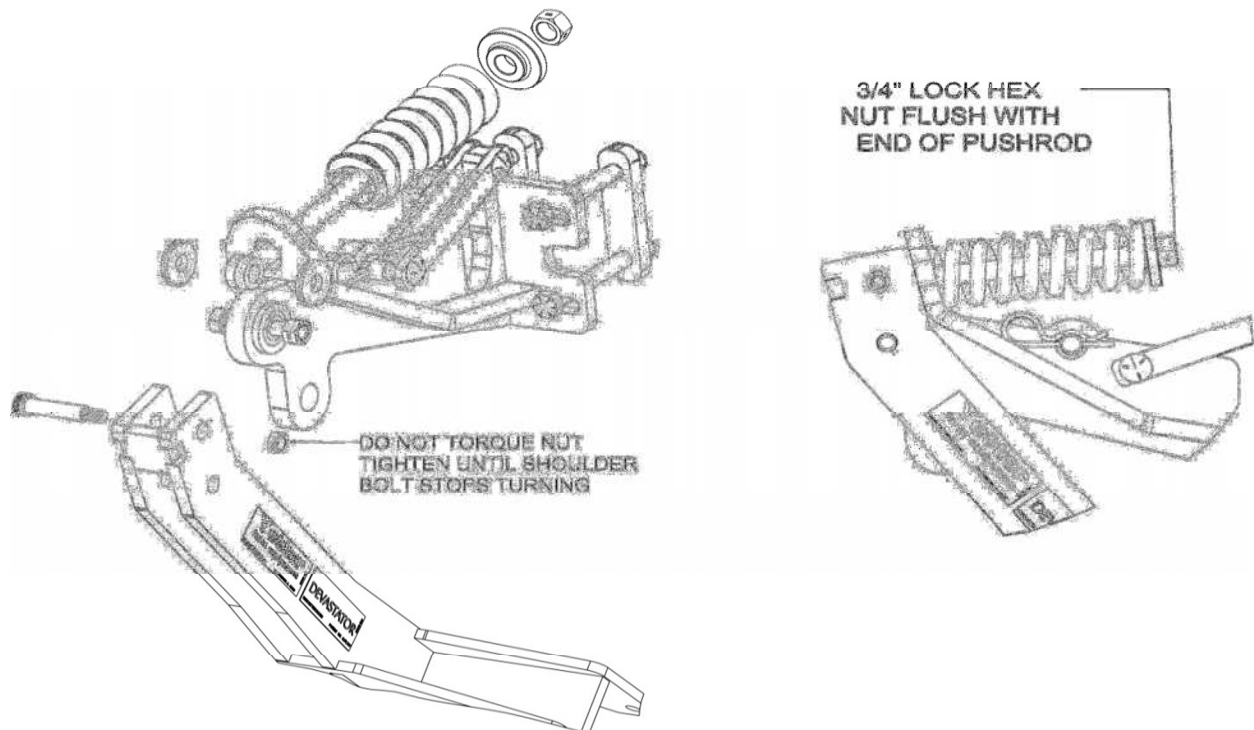

**NOTE:** Tightening the nut on the spring bushing more will result in added down pressure. However, DO NOT tighten the nut on the spring bushing down so far that spring compression limits pivot arm travel. This will cause the spring to break, especially if spring is compressed all off-season.



# 5000-025A ASSEMBLY INSTRUCTIONS

**Step 6:** Secure the mounting bracket installed in **Step 1** at this time by tightening the 5/8 X 6" bolts & 5/8 lock nuts. Make sure the compression spring clears the cylinder channel as well as the rocker arm of the deck plate adjustment. The offset pivot arm clamp (5000-256 & 5000-259) should be under the snout, not directly under the row.

Row 1 & 2

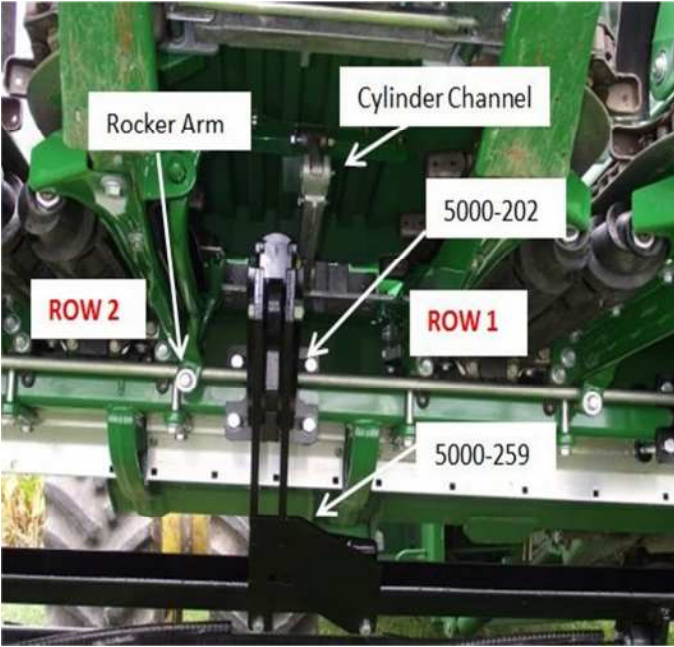

Row 2 & 3

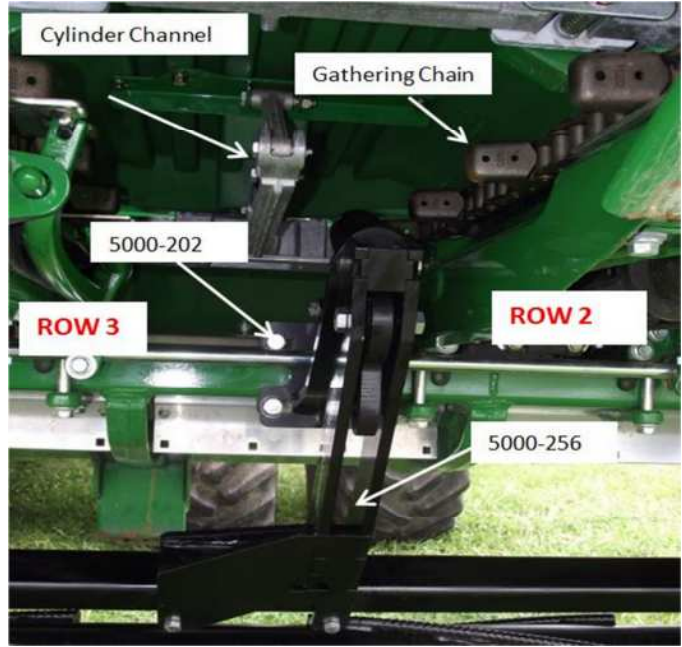

Row 4 & 5

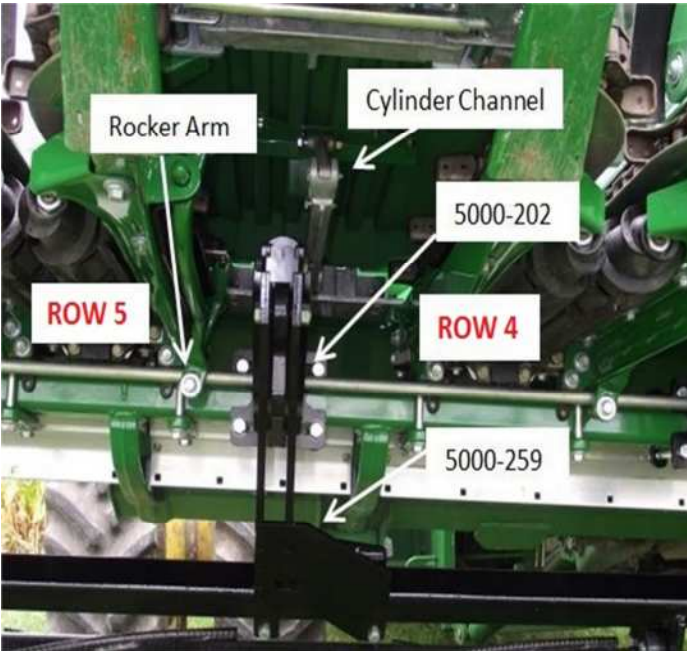

Row 5 & 6

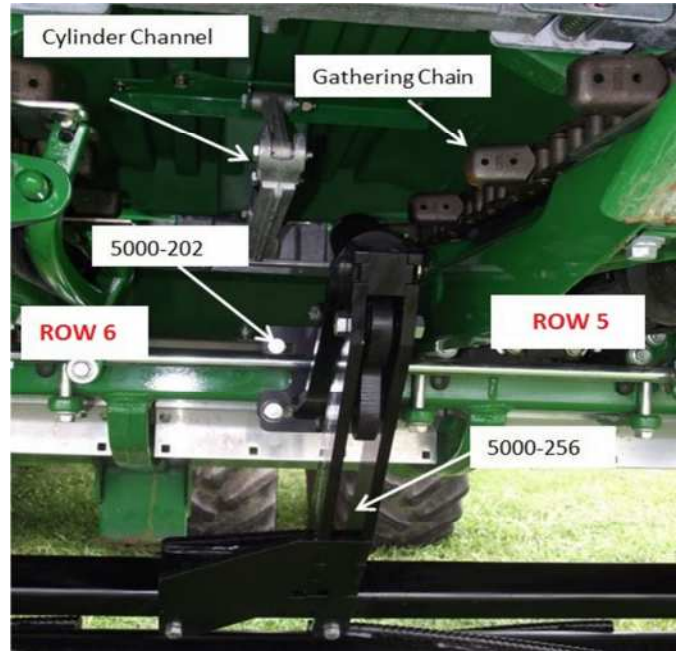

**Note:** On 12 row heads installing on wheel tracks only, the top pictures on this page will illustrate rows 4 & 5 and 5 & 6. The bottom pictures on this page will illustrate rows 7 & 8 and 8 & 9.

**Note:** On 16 row heads installing on wheel tracks only, the top pictures on this page will illustrate rows 6 & 7 and 7 & 8. The bottom pictures on this page will illustrate rows 9 & 10 and 10 & 11.

# 5000-025A ASSEMBLY INSTRUCTIONS

**Step 7:** Install the Roller Arm Mount Tube inside the clamp channel of the pivot arms using the 5000-138 bolt bag. Do not tighten this hardware until after the rollers have been installed in **Step 8**.

**NOTE:** Install the Roller Arm Mount Tube on so that the bearing support tab is on the back side to help support the bearings.

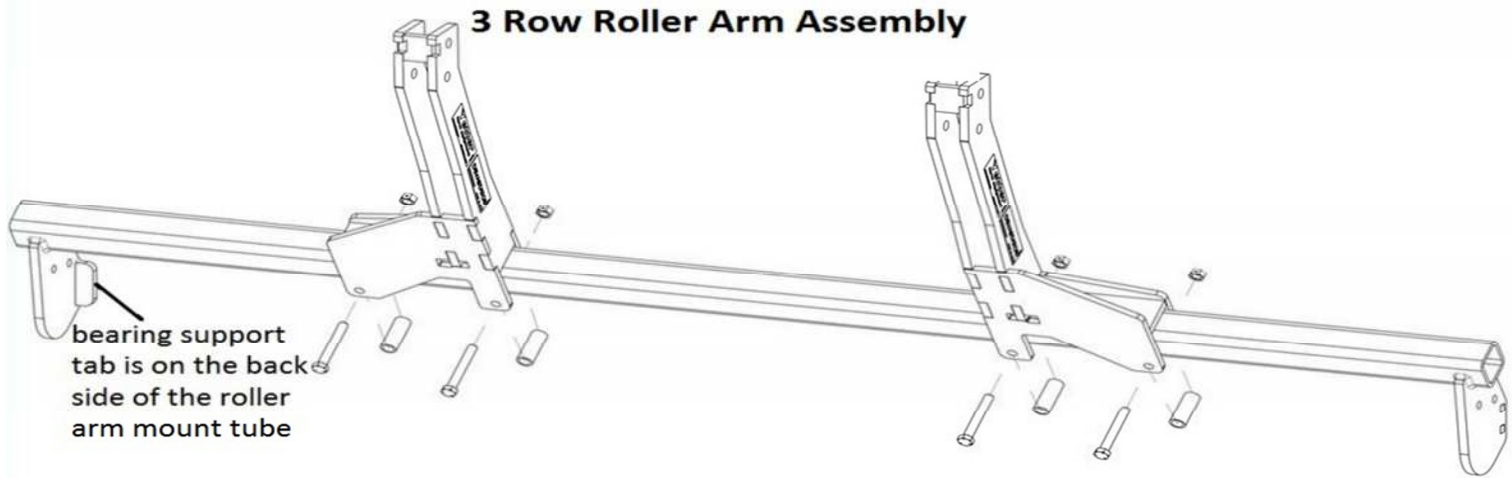

**Step 8:** Insert the shim washer over the shaft on each end of the roller. Install the bearing over the shaft on each end of the roller so that the side of the casting that has the bearing protruding past the housing surface is towards the roller barrel & shim washer. Lift each roller into place, traction bar in front of the rebar, so that the bolt holes on the cast line up with the mounting tabs on the roller arm mount tube. Install the  $\frac{1}{2}$ " X  $2\frac{1}{2}$ " bolts & tighten the  $\frac{1}{2}$ " lock nuts. Once the roller & bearing hardware is fastened, spin the roller to ensure the bearing was installed correctly. If the roller was installed incorrectly, the roller will not spin or will have drag. Slide the roller mount tube to gain clearance on each end of the corn head & then tighten the hardware from **Step 7**. The traction bars DO NOT have to be directly centered under each row.

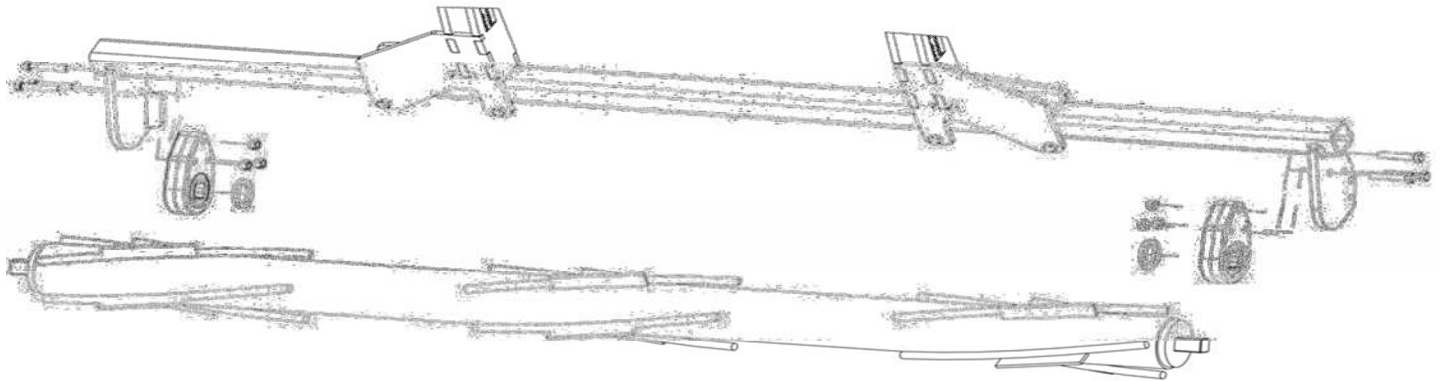

THE SIDE OF THE BEARING ASSEMBLY WHERE THE BEARING IS PROTRUDING MUST BE INSTALLED TOWARD THE ROLLER!

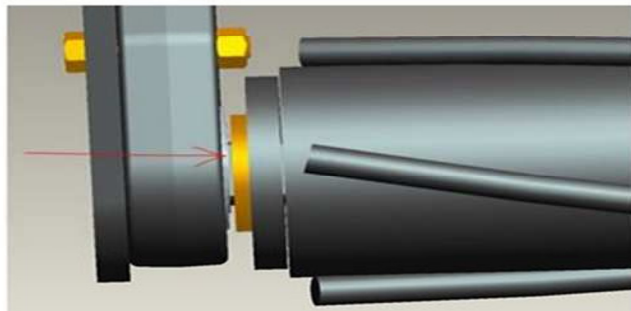



# 5000-026A ASSEMBLY INSTRUCTIONS

(JD 608C, 708C, 843, & 893)

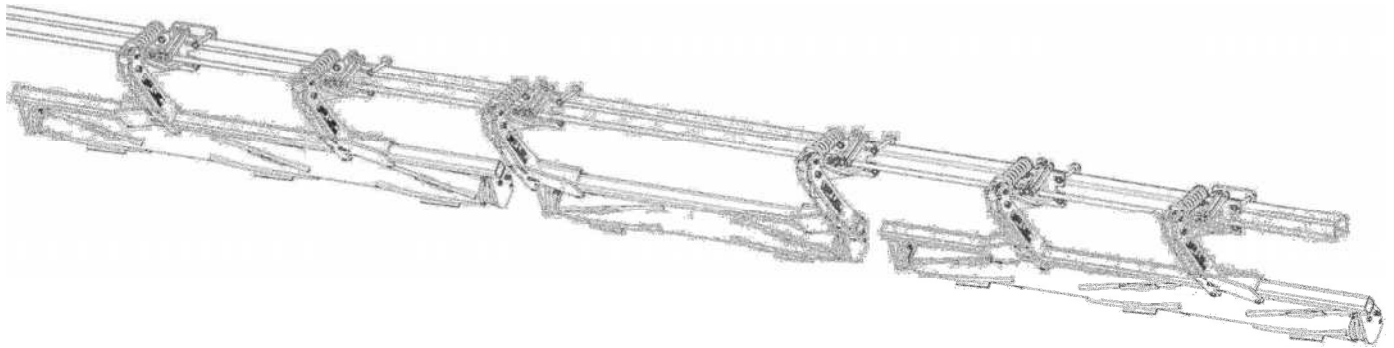

**Step 1:** Attach the 5000-202 mount brackets to the frame using the 5/8 x 6 bolts, mounting straps, & 5/8" lock hex nuts. Mounting Brackets will be located under the snouts between rows 1 & 2, 2 & 3, 3 & 4, 5 & 6, 6 & 7, and 7 & 8. Slide the mount bracket up so the deck plate adjustment rod is located in the cut out of the mount bracket. On JD 893 corn heads, use the 5000-301 L Clamp Plate with the mounting brackets between rows 1 & 2 and 7 & 8. If corn head is equipped with protective shield (like pic with the arrow shows), you can either: remove each shield, cut a notch in each shield, or bend each shield upwards to gain clearance. The shields on a 90 series head will need removed.

**Note:** Do not fully tighten hardware until **Step 6** after all of the pivot arms & springs are installed.

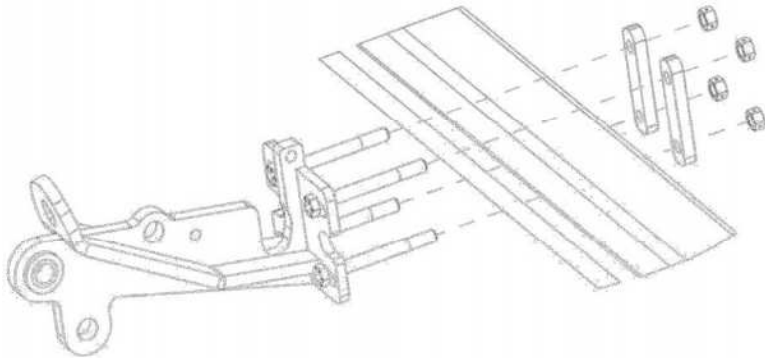

MOUNTING BRACKET ASSEMBLY INSTRUCTIONS (ROW 1-2 AND 7-8)  
JD 893 (8 ROW) CORN HEAD (ONLY)

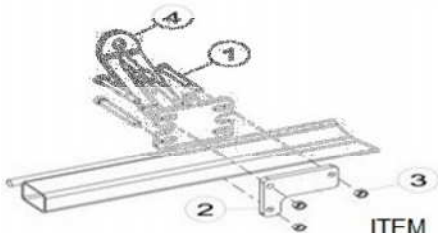

LEFT HAND  
ROWS 1-2

ITEM	PART #	DESCRIPTION
1	2502-352	5/8 - 11 X 6 HHCS GR 8 ZP
2	5000-301	"L" MOUNT PLATE JD 90 SERIES
3	2520-459	5/8 - 11 HEX LOCK NUT ZP
4	5000-202	MOUNT BRACKET W.A., SINGLE

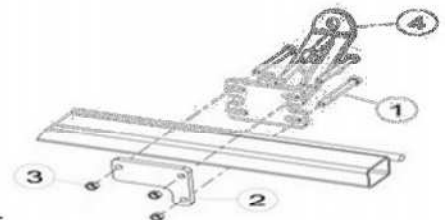

RIGHT HAND  
ROWS 7-8

Arrows indicate 5000-202 mount bracket locations

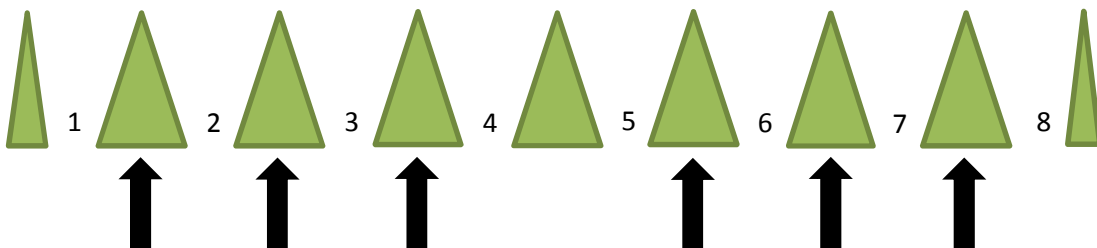

# 5000-026A ASSEMBLY INSTRUCTIONS

**Step 2:** Attach the 5000-309 support straps using 1/2" x 2" carriage bolts & 1/2" flange lock nuts, tighten.

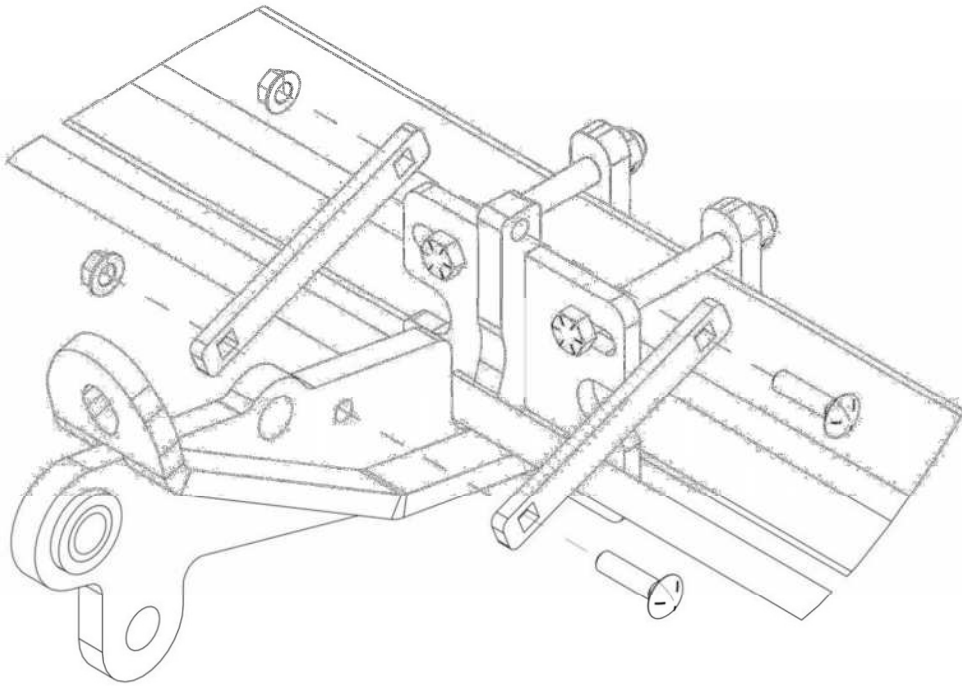

**Step 3:** Install the 5000-323 lock-up pin in the storage location on the mount brackets. Secure with the hairpin clips.

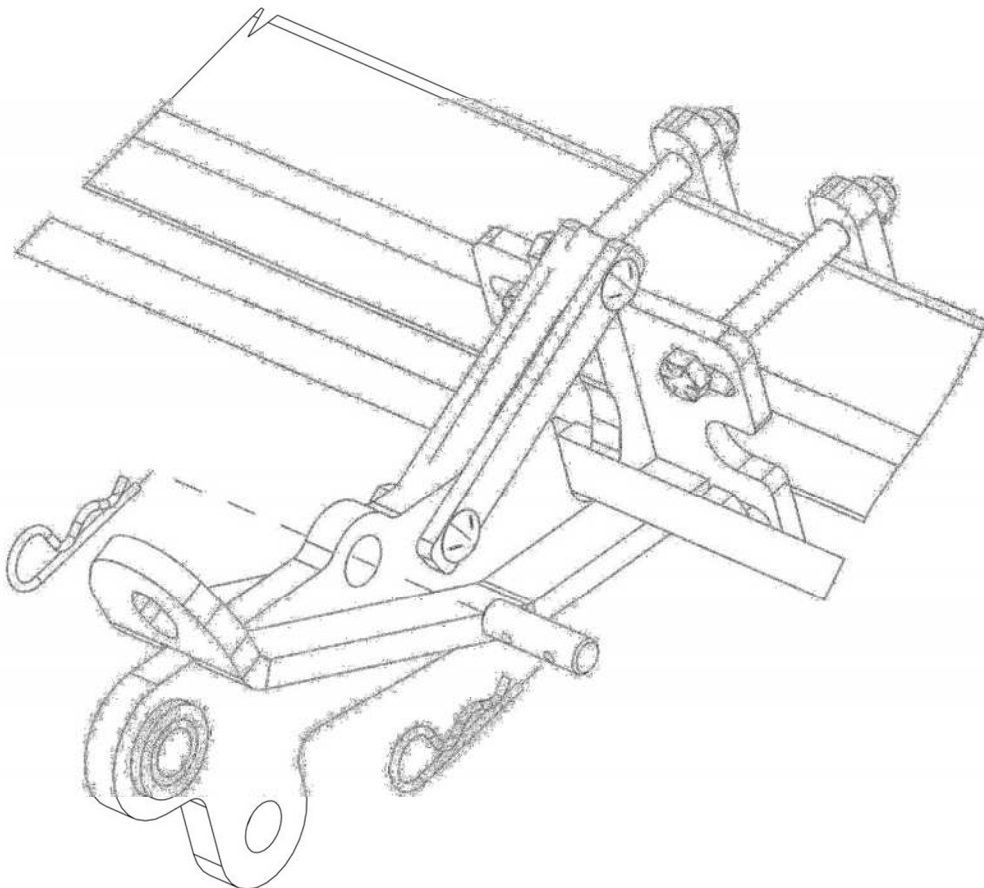

# 5000-026A ASSEMBLY INSTRUCTIONS

**Step 4:** Attach the pivot arms to the mount brackets using 5/8" X 3" bolts, pivot bushings, & 5/8" lock hex nuts. Use the model below to determine where the LH & RH pivot arms get installed. Tighten this hardware.

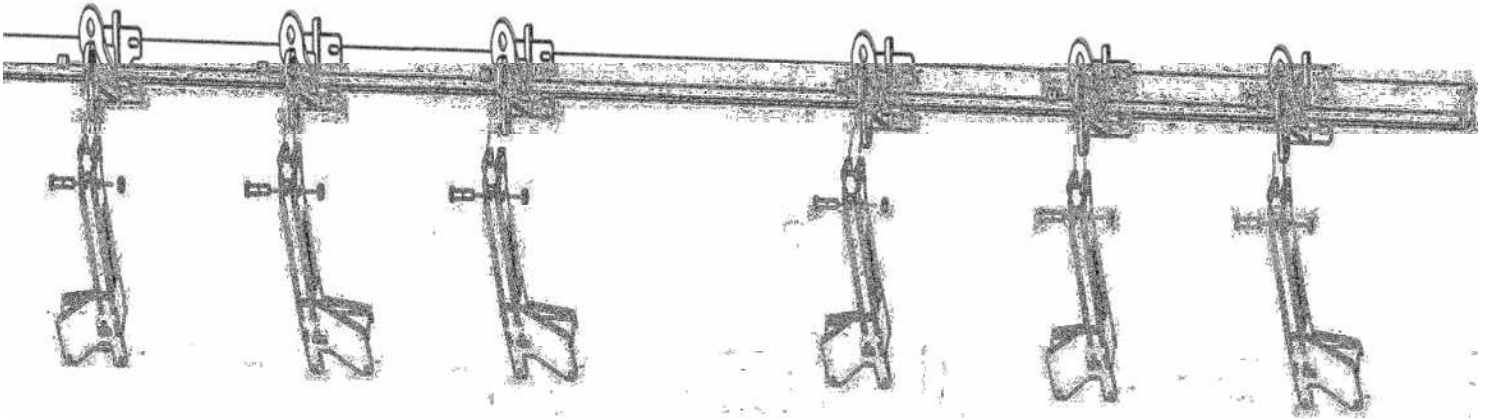

**Step 5:** Install the push rods into the mount brackets then attach to the pivot arms with the 5/8" shoulder bolts, washers, and 1/2" jam lock nuts.

**Note:** The washers are installed on each side of the "eye" of the push rod.

Now install the compression spring, spring bushing, and 3/4" lock hex nuts. Tighten the hardware from **Step 5** to the specification in the diagram below.

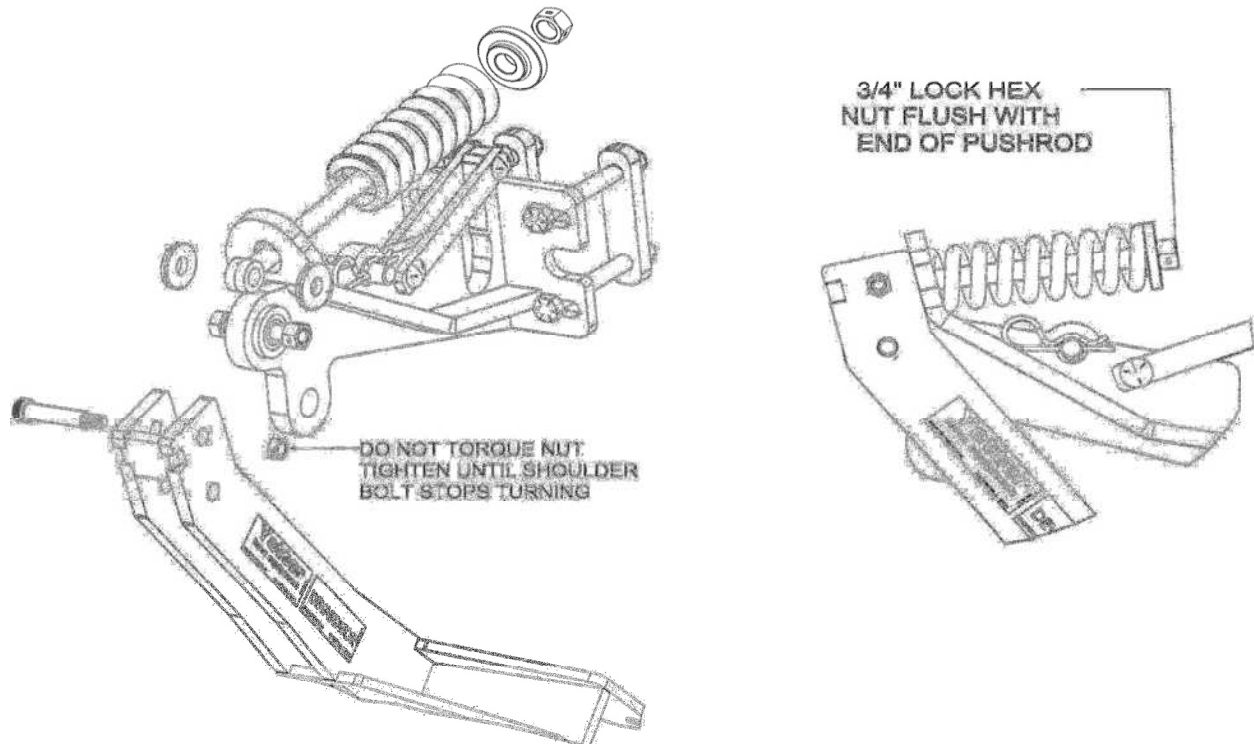

**NOTE:** Tightening the nut on the spring bushing more will result in added down pressure. However, DO NOT tighten the nut on the spring bushing down so far that spring compression limits pivot arm travel. This will cause the spring to break, especially if spring is compressed all off-season.



# 5000-026A ASSEMBLY INSTRUCTIONS

**Step 6:** Secure the mounting bracket installed in **Step 1** at this time by tightening the 5/8 X 6" bolts & 5/8" lock nuts. Make sure the compression spring clears the cylinder channel as well as the rocker arm of the deck plate adjustment. The offset pivot arm clamp should be under the snout, not directly under the row.

Row 1 & 2

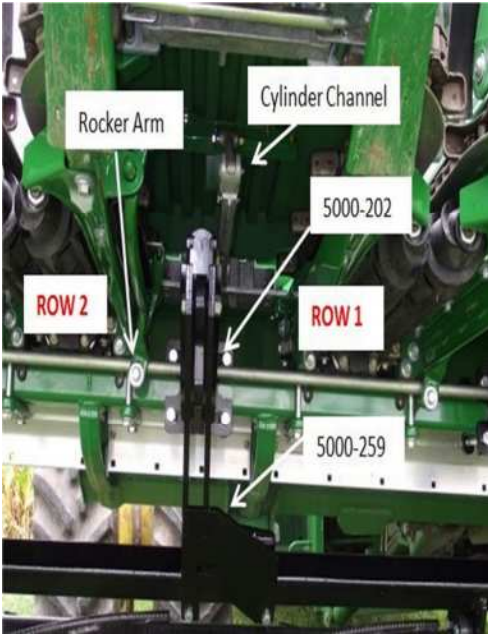

Row 2 & 3



Row 3 & 4

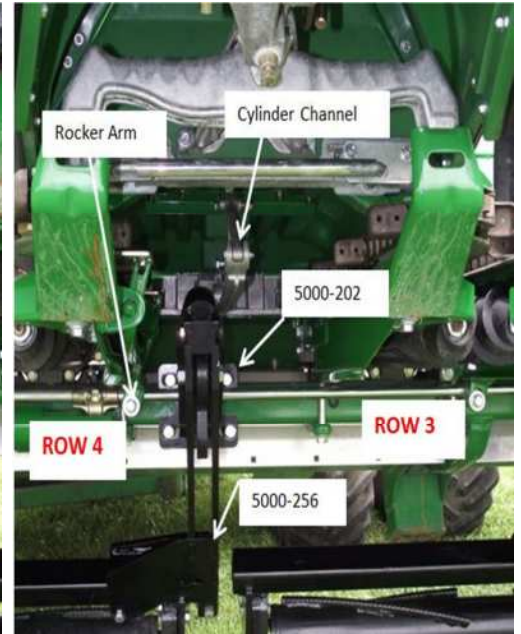

Row 5 & 6



Row 6 & 7

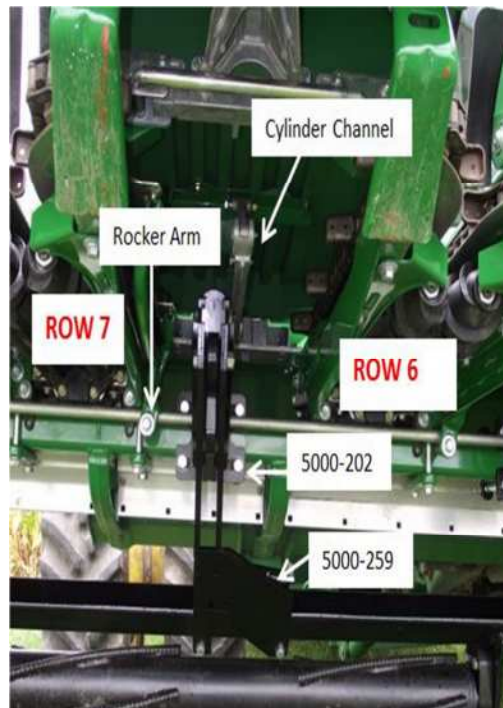

Row 7 & 8

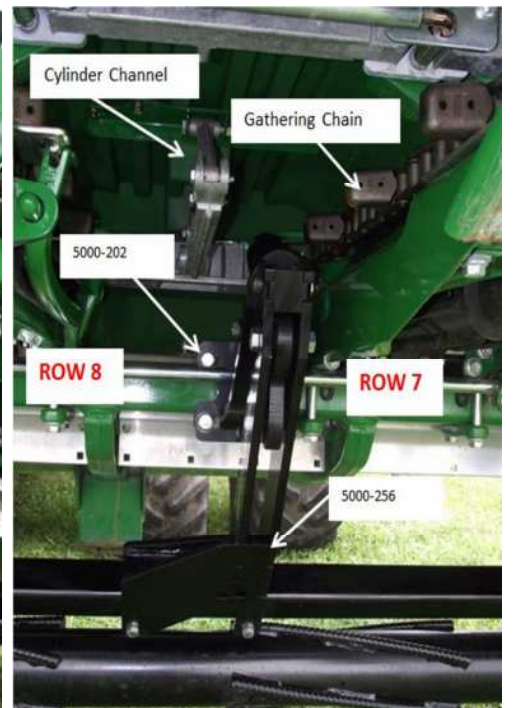

# 5000-026A ASSEMBLY INSTRUCTIONS

**Step 7:** Install the Roller Arm Mount Tube inside the clamp channel of the pivot arms using the 5000-138 bolt bag. Do not tighten this hardware until after the rollers have been installed in **Step 8**.

**NOTE:** Install the 2 & 3 row Roller Arm Mount Tube on so that the bearing support tab is on the back side to help support the bearings.

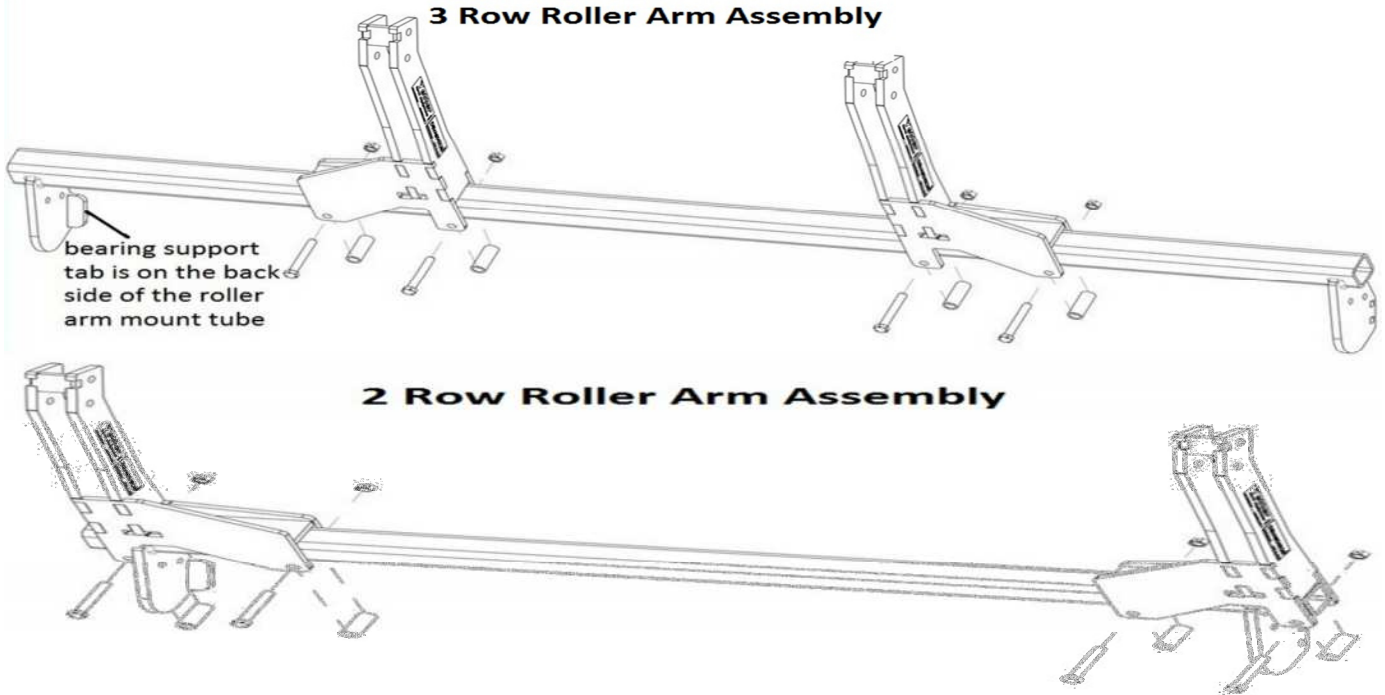

**Step 8:** Insert the shim washer over the shaft on each end of the roller. Install the bearing over the shaft on each end of the roller so that the side of the casting that has the bearing protruding past the housing surface is towards the roller barrel & shim washer. Lift each roller into place, traction bar in front of the rebar, so that the bolt holes on the cast line up with the mounting tabs on the roller arm mount tube. Install the 1/2" X 2 1/2" bolts and tighten the 1/2" lock nuts. Once the roller & bearing hardware is fastened, spin the roller to ensure the bearing was installed correctly. If the roller was installed incorrectly, the roller will not spin or will have drag. Slide the roller mount tube to gain clearance on each end of the corn head & then tighten the hardware from **Step 7**. The traction bars DO NOT have to be directly centered under each row.

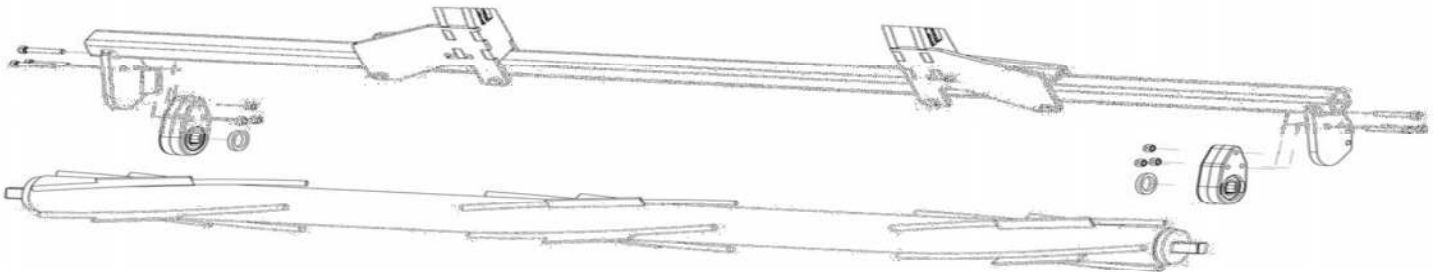

THE SIDE OF THE BEARING ASSEMBLY WHERE THE BEARING IS PROTRUDING MUST BE INSTALLED TOWARD THE ROLLER!

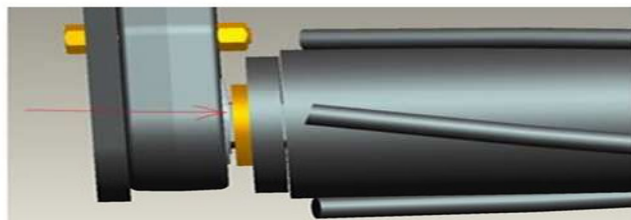



# 5000-027A ASSEMBLY INSTRUCTIONS

(JD 612C, 712C, 1243, & 1293)

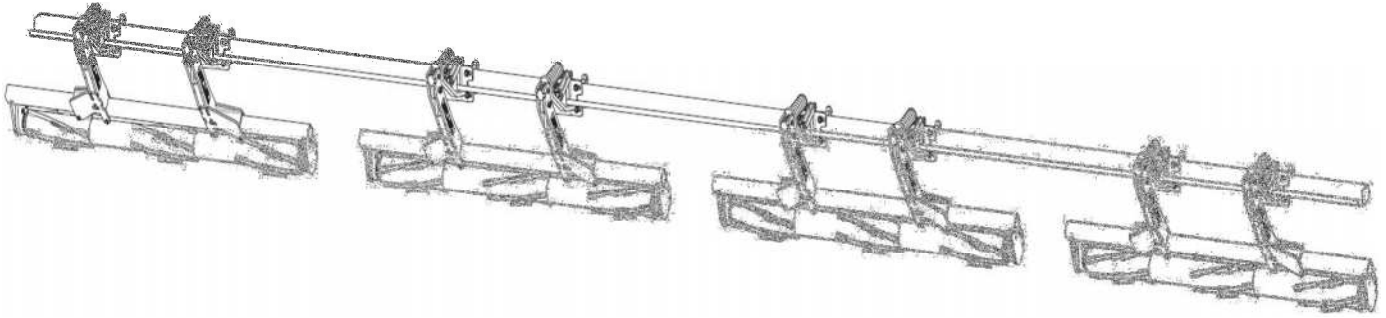

**Step 1:** Attach the 5000-202 mount brackets to the frame using the 5/8 x 6 bolts, mounting straps, & 5/8" lock hex nuts. Mounting Brackets will be located under the snouts between rows 1 & 2, 2 & 3, 4 & 5, 5 & 6, 7 & 8, 8 & 9, 10 & 11, and 11 & 12. Slide the mount bracket up so the deck plate adjustment rod is located in the cut out of the mount bracket. On JD 1293 corn heads, use the 5000-301 L Clamp Plate with the mounting brackets between rows 2 & 3 and 10 & 11. If corn head is equipped with protective shield (like pic with the arrow shows), you can either: remove each shield, cut a notch in each shield, or bend each shield upwards to gain clearance. The shields on a 90 series head will need removed.

**Note:** Do not fully tighten hardware until **Step 6** after all of the pivot arms & springs are installed.

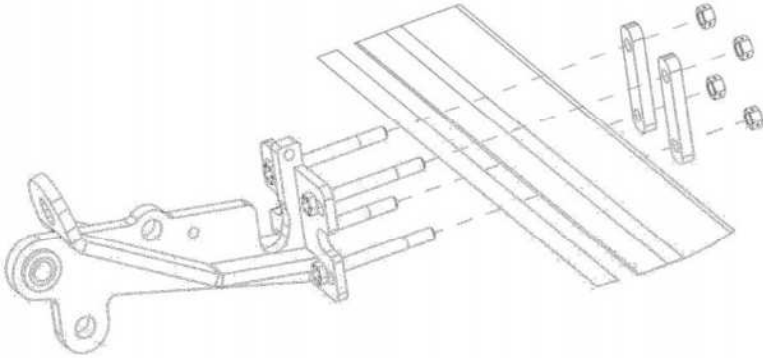

MOUNTING BRACKET ASSEMBLY INSTRUCTIONS (ROW 2-3 AND 10-11)  
JD 1293 (12 ROW) CORN HEAD (ONLY)

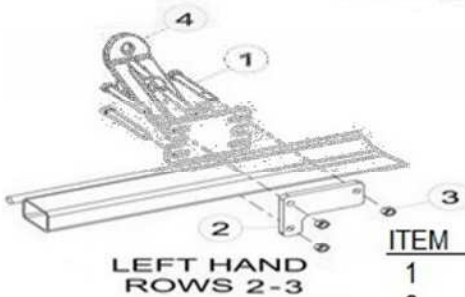

LEFT HAND  
ROWS 2-3

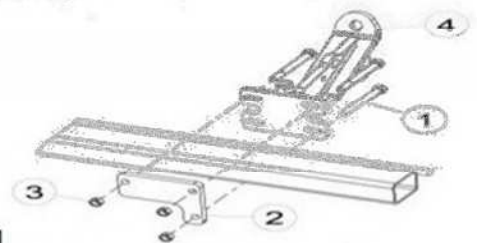

RIGHT HAND  
ROWS 10-11

ITEM	PART #	DESCRIPTION
1	2502-352	5/8 - 11 X 6 HHCS GR 8 ZP
2	5000-301	"L" MOUNT PLATE JD 90 SERIES
3	2520-459	5/8 - 11 HEX LOCK NUT ZP
4	5000-202	MOUNT BRACKET W.A., SINGLE

Arrows indicate 5000-202 mount bracket locations

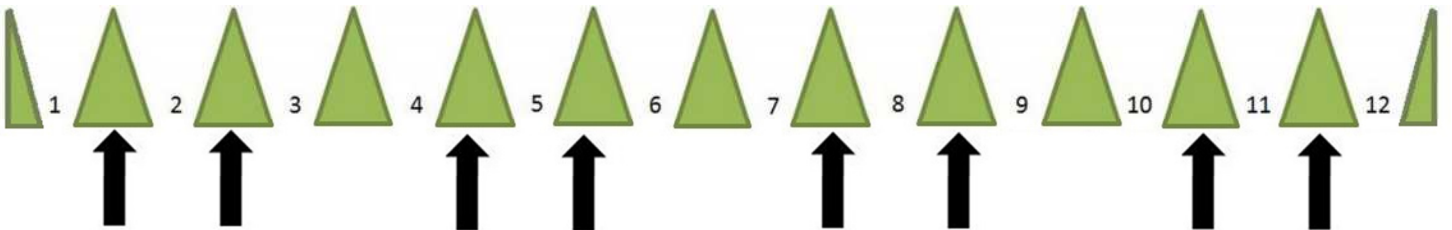

# 5000-027A ASSEMBLY INSTRUCTIONS

**Step 2:** Attach the 5000-309 support straps using 1/2" x 2" carriage bolts & 1/2" flange lock nuts, tighten.

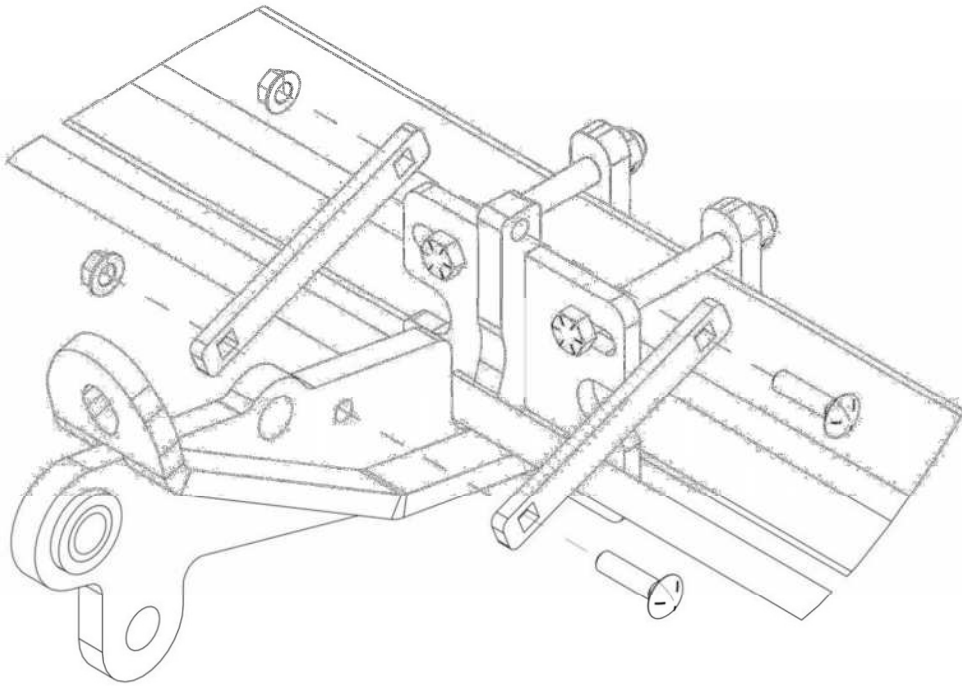

**Step 3:** Install the 5000-323 lock-up pin in the storage location on the mount brackets. Secure with the hairpin clips.

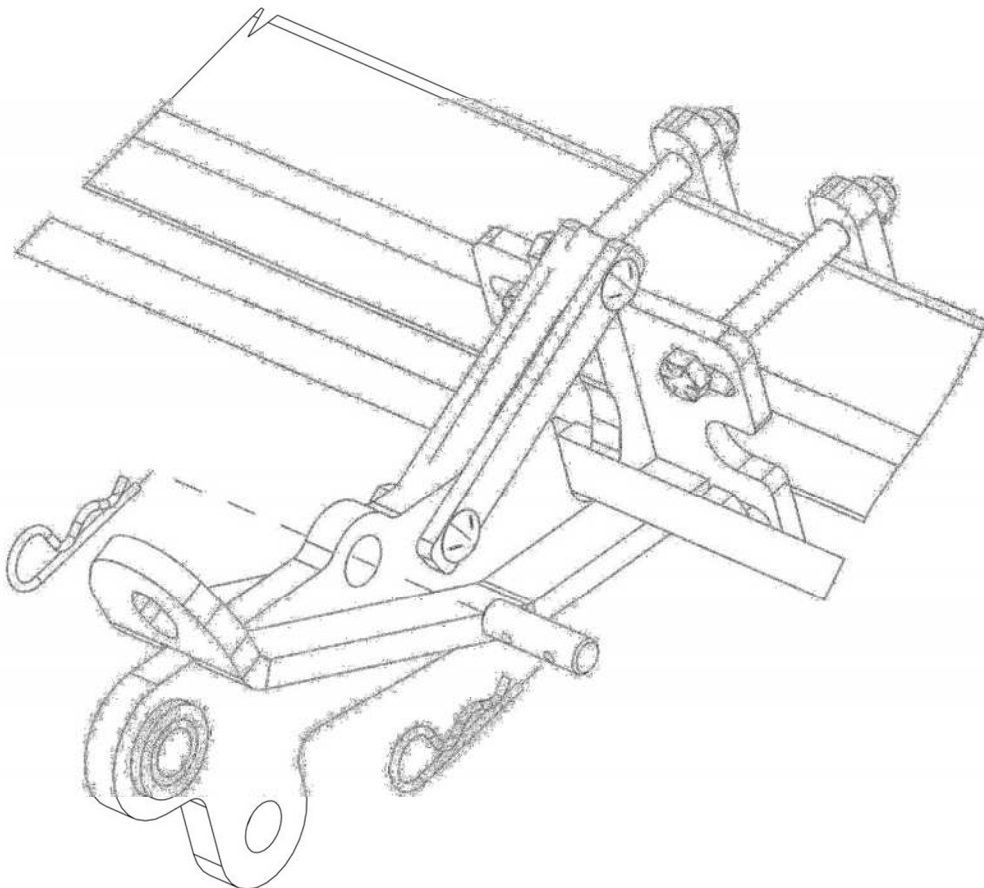

# 5000-027A ASSEMBLY INSTRUCTIONS

**Step 4:** Attach the pivot arms to the mount brackets using 5/8" X 3" bolts, pivot bushings, & 5/8" lock hex nuts. Use the model below to determine where the LH & RH pivot arms get installed. Tighten this hardware.

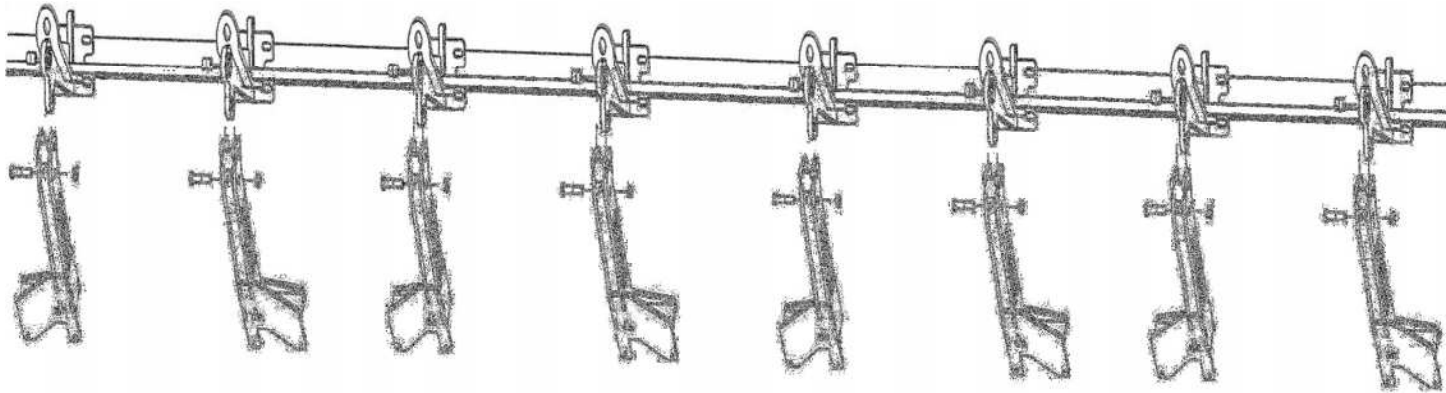

**Step 5:** Install the push rods into the mount brackets then attach to the pivot arms with the 5/8" shoulder bolts, washers, and 1/2" jam lock nuts.

**Note:** The washers are installed on each side of the "eye" of the push rod.

Now install the compression spring, spring bushing, and 3/4" lock hex nuts. Tighten the hardware from **Step 5** to the specification in the diagram below.

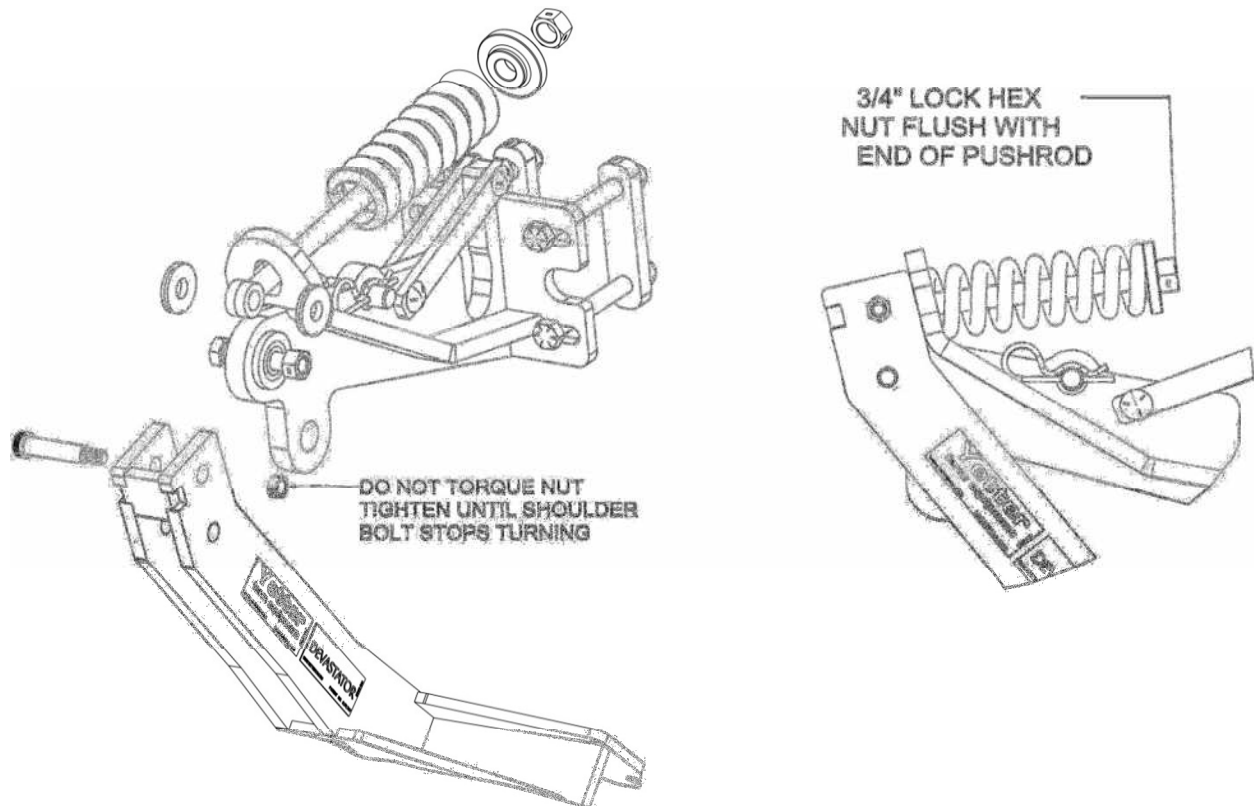

**NOTE:** Tightening the nut on the spring bushing more will result in added down pressure. However, DO NOT tighten the nut on the spring bushing down so far that spring compression limits pivot arm travel. This will cause the spring to break, especially if spring is compression all off-season.



# 5000-027A ASSEMBLY INSTRUCTIONS

**Step 6:** Secure the mounting bracket installed in **Step 1** at this time by tightening the 5/8 X 6" bolts & 5/8 lock nuts. Make sure the compression spring clears the cylinder channel as well as the rocker arm of the deck plate adjustment. The offset pivot arm clamp should be under the snout, not directly under the row.

Row 1 & 2

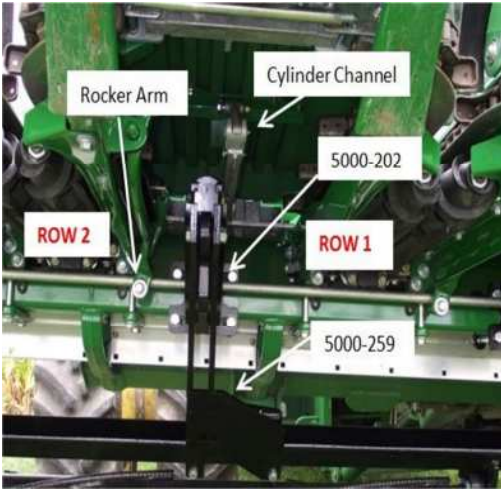

Row 2 & 3

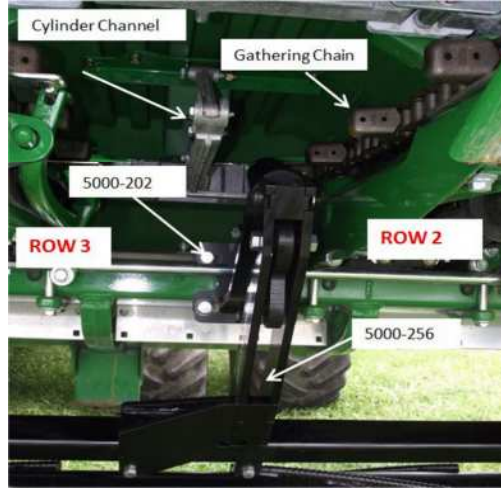

Row 4 & 5

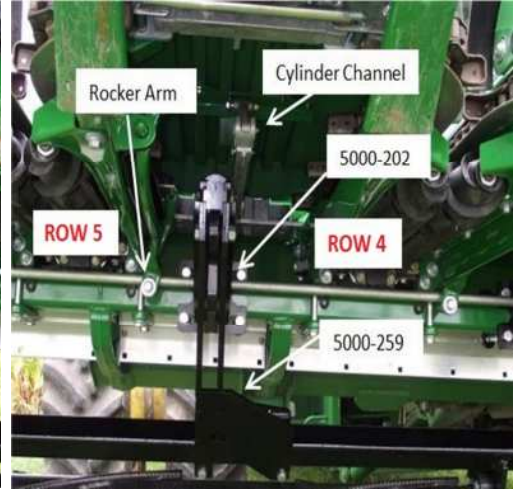

Row 5 & 6

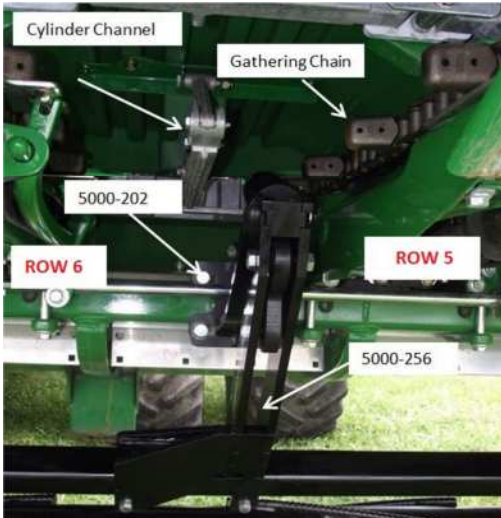

Row 7 & 8

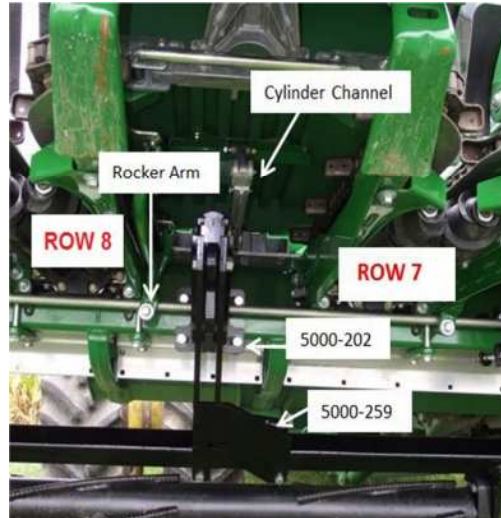

Row 8 & 9

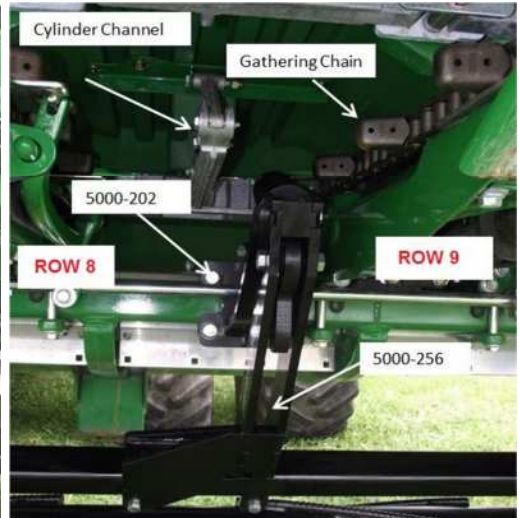

Row 10 & 11

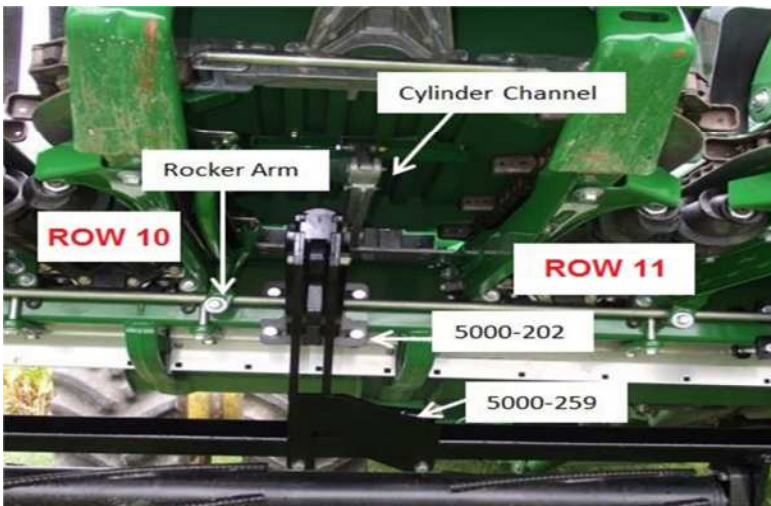

Row 11 & 12

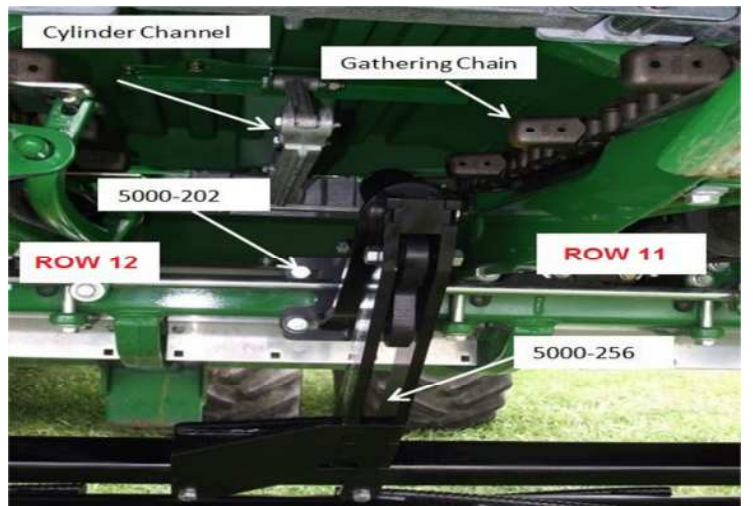

# 5000-027A ASSEMBLY INSTRUCTIONS

**Step 7:** Install the Roller Arm Mount Tube inside the clamp channel of the pivot arms using the 5000-138 bolt bag. Do not tighten this hardware until after the rollers have been installed in **Step 8**.

**NOTE:** Install the Roller Arm Mount Tube on so that the bearing support tab is on the back side to help support the bearings.



**Step 8:** Insert the shim washer over the shaft on each end of the roller. Install the bearing over the shaft on each end of the roller so that the side of the casting that has the bearing protruding past the housing surface is towards the roller barrel & shim washer. Lift each roller into place, traction bar in front of the rebar, so that the bolt holes on the cast line up with the mounting tabs on the roller arm mount tube. Install the  $\frac{1}{2}$ " X  $2 \frac{1}{2}$ " bolts and tighten the  $\frac{1}{2}$ " lock nuts. Once the roller & bearing hardware is fastened, spin the roller to ensure the bearing was installed correctly. If the roller was installed incorrectly, the roller will not spin or will have drag. Slide the roller mount tube to gain clearance on each end of the corn head & then tighten the hardware from **Step 7**. The traction bars DO NOT have to be directly under the row.

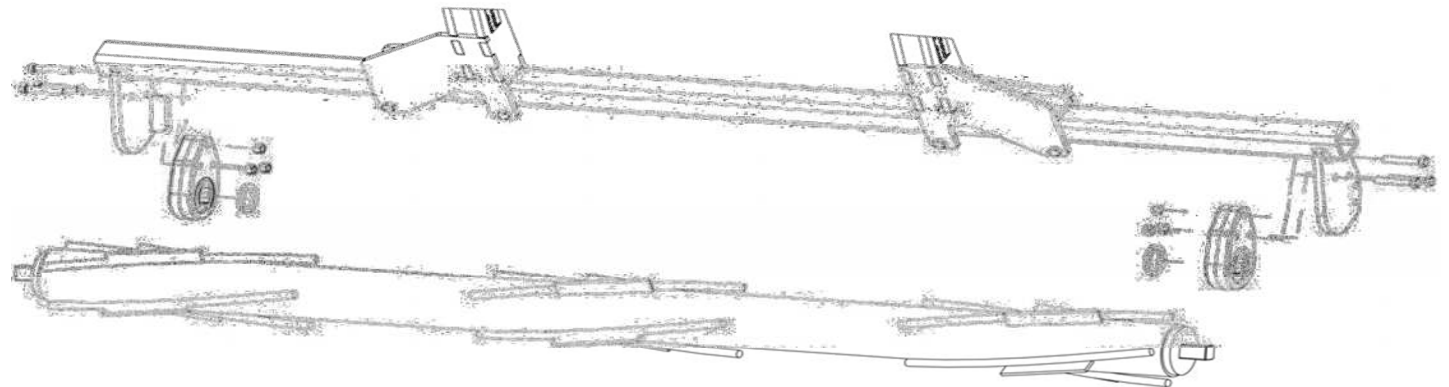

THE SIDE OF THE BEARING ASSEMBLY WHERE THE BEARING IS PROTRUDING MUST BE INSTALLED TOWARD THE ROLLER!

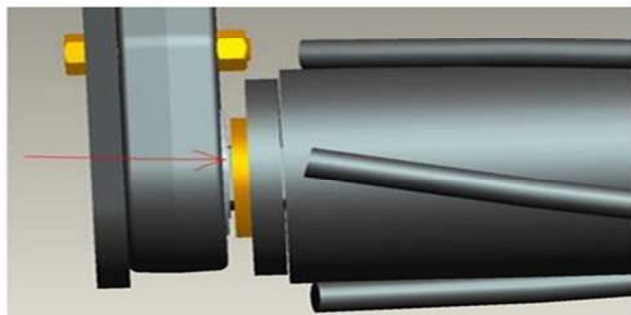



# 5000-028A ASSEMBLY INSTRUCTIONS

(JD 616C & 716C)

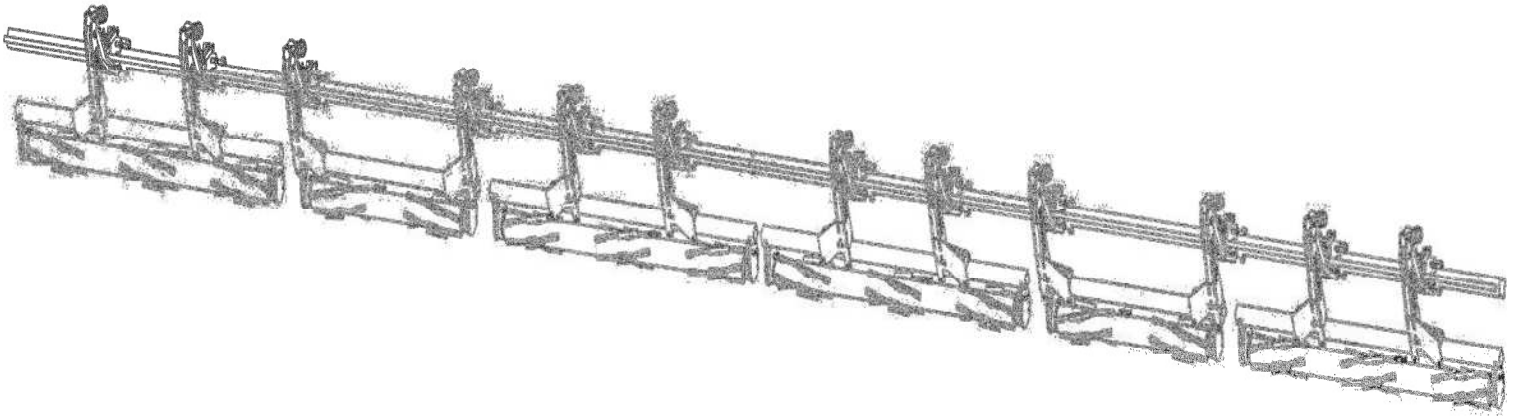

**Step 1:** Attach the 5000-202 mount brackets to the frame using the 5/8 x 6 bolts, mounting straps, & 5/8" lock hex nuts. Mounting Brackets will be located under the snouts between rows 1 & 2, 2 & 3, 4 & 5, 5 & 6, 7 & 8, 8 & 9, 10 & 11, and 11 & 12. Slide the mount bracket up so the deck plate adjustment rod is located in the cut out of the mount bracket. If corn head is equipped with protective shield (like pic with the arrow shows), you can either: remove each shield, cut a notch in each shield, or bend each shield upwards to gain clearance. The shields on a 90 series head will need removed.

**Note:** Do not fully tighten hardware until **Step 6** after all of the pivot arms & springs are installed.

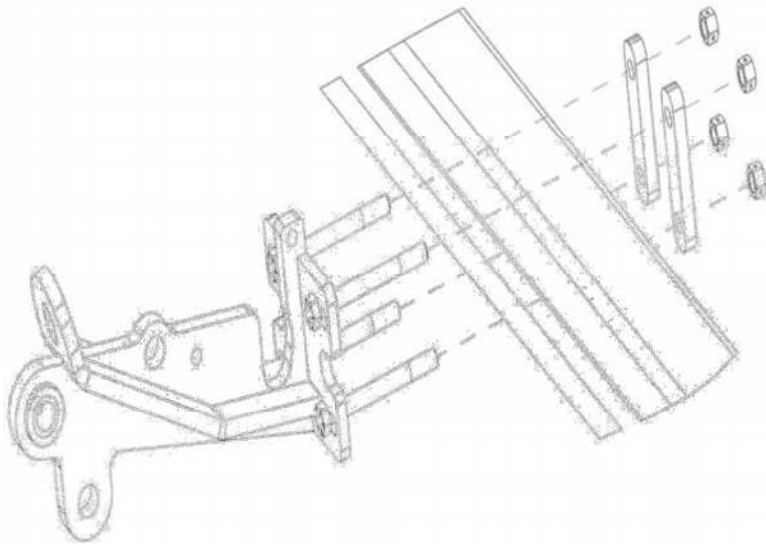

Arrows indicate 5000-202 mount bracket locations

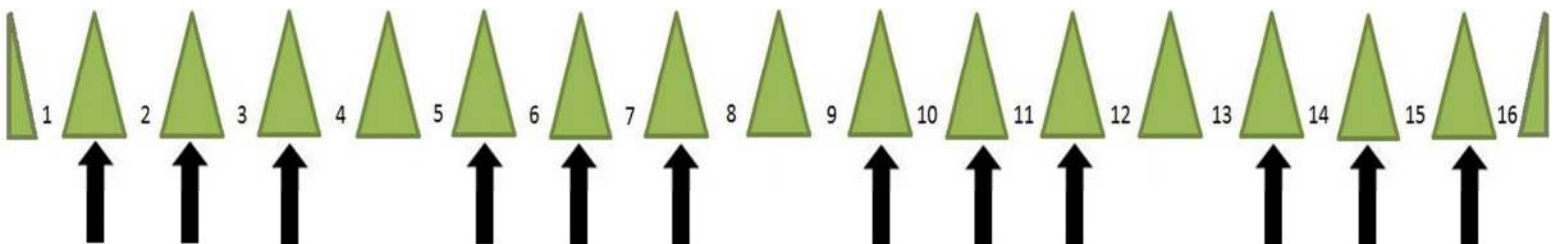

# 5000-028A ASSEMBLY INSTRUCTIONS

**Step 2:** Attach the 5000-309 support straps using 1/2" x 2" carriage bolts & 1/2" flange lock nuts, tighten.

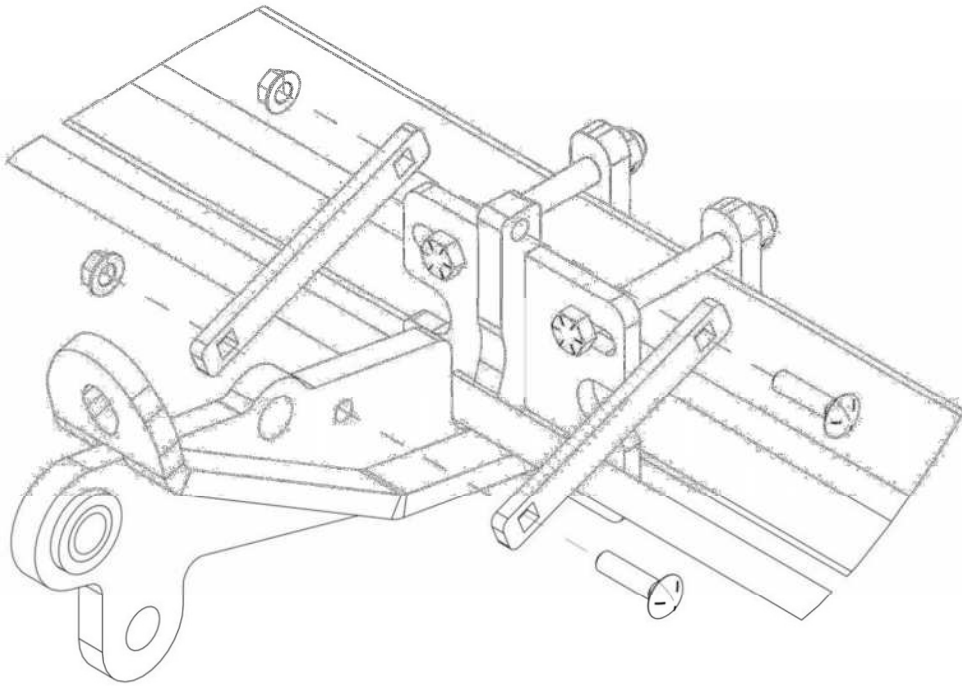

**Step 3:** Install the 5000-323 lock-up pin in the storage location on the mount brackets. Secure with the hairpin clips.

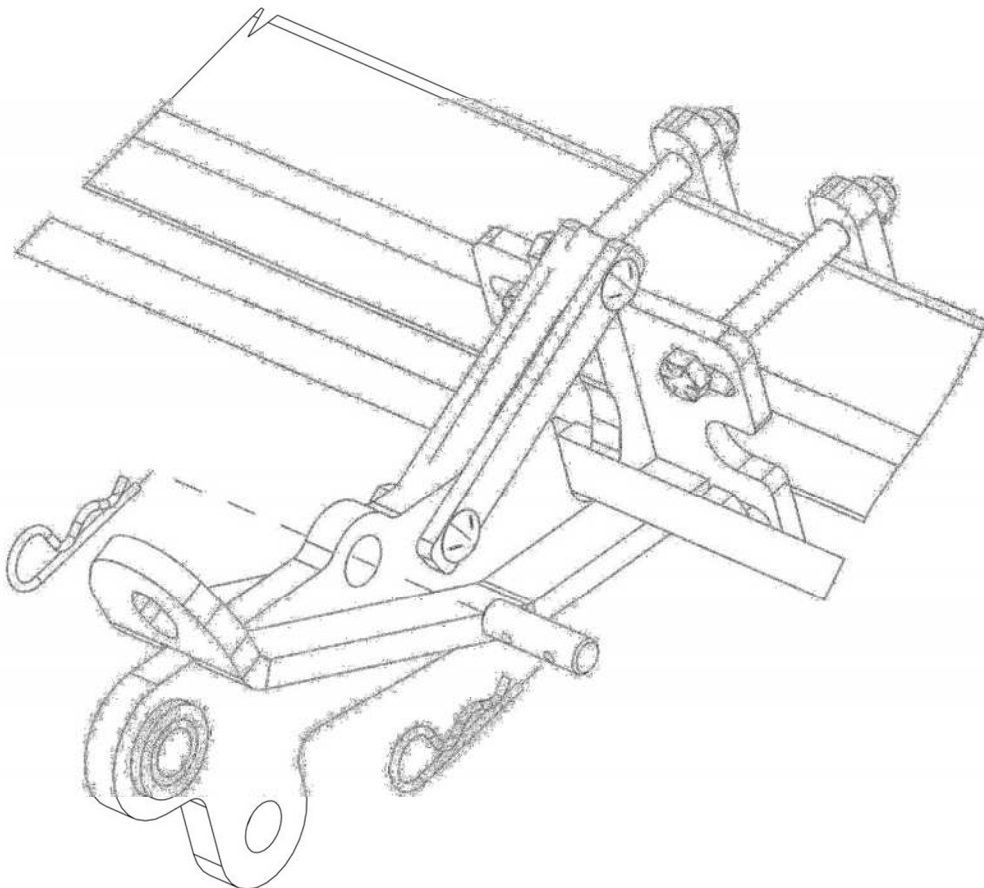

# 5000-028A ASSEMBLY INSTRUCTIONS

**Step 4:** Attach the pivot arms to the mount brackets using 5/8" X 3" bolts, pivot bushings, & 5/8" lock hex nuts. Use the model below to determine where the LH & RH pivot arms get installed. Tighten this hardware.

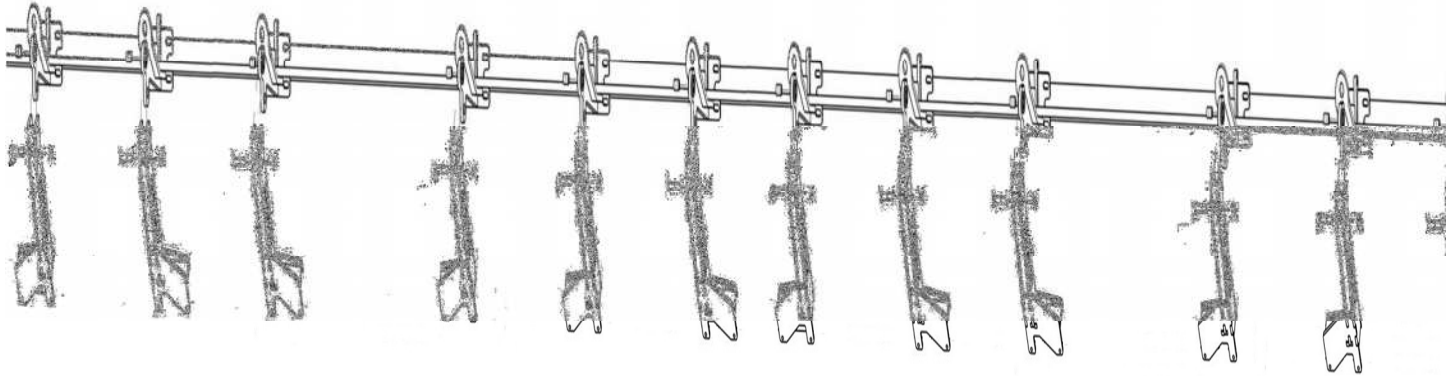

**Step 5:** Install the push rods into the mount brackets then attach to the pivot arms with the 5/8" shoulder bolts, washers, and 1/2" jam lock nuts.

**Note:** The washers are installed on each side of the "eye" of the push rod.

Now install the compression spring, spring bushing, and 3/4" lock hex nuts. Tighten the hardware from **Step 5** to the specification in the diagram below.

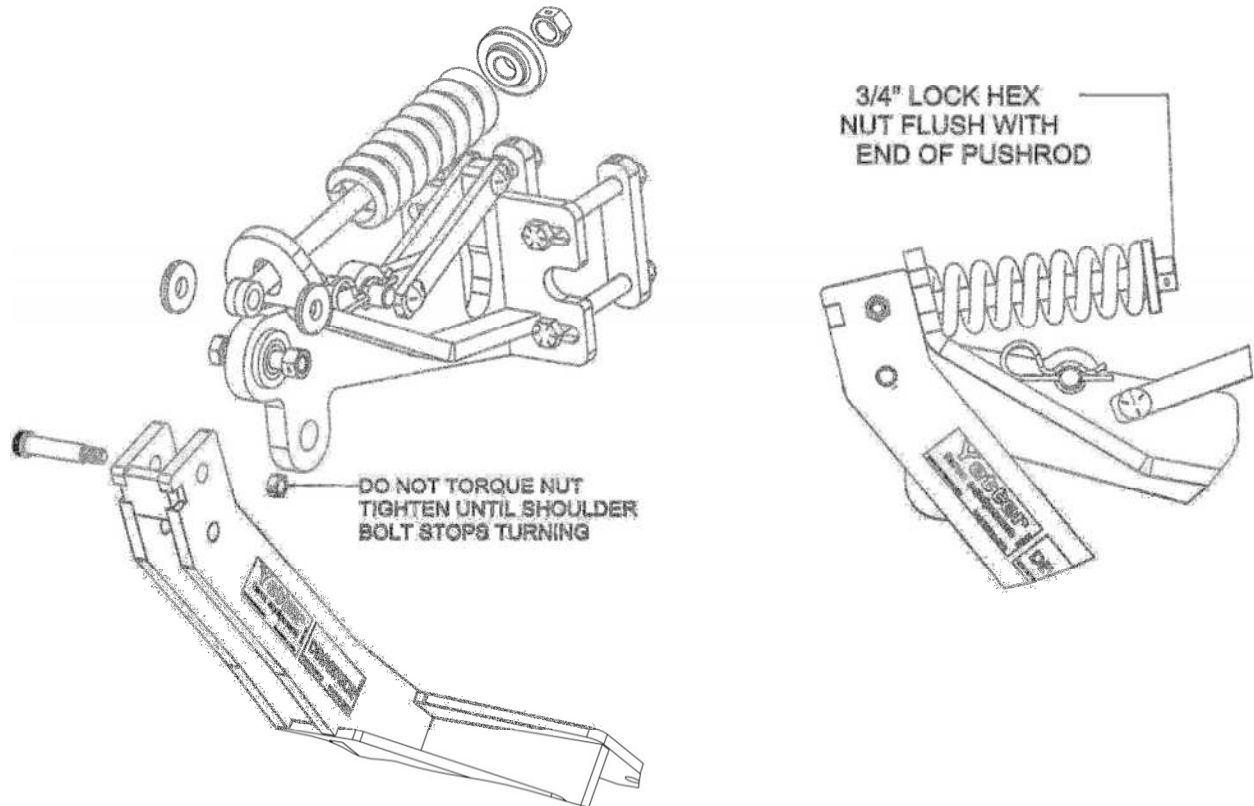

**NOTE:** Tightening the nut on the spring bushing more will result in added down pressure. However, DO NOT tighten the nut on the spring bushing down so far that spring compression limits pivot arm travel. This will cause the spring to break, especially if spring is compression all off-season.



# 5000-028A ASSEMBLY INSTRUCTIONS

**Step 6:** Secure the mounting bracket installed in **Step 1** at this time by tightening the 5/8 X 6" bolts & 5/8 lock nuts. Make sure the compression spring clears the cylinder channel as well as the rocker arm of the deck plate adjustment. The offset pivot arm clamp should be under the snout, not directly under the row.

Row 1 & 2

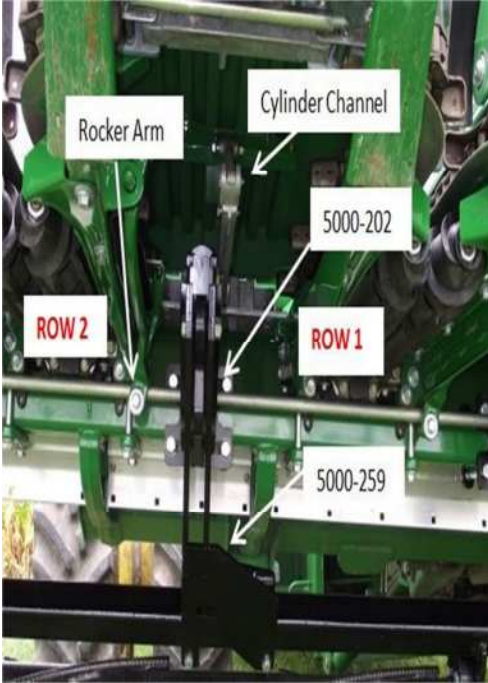

Row 2 & 3



Row 3 & 4

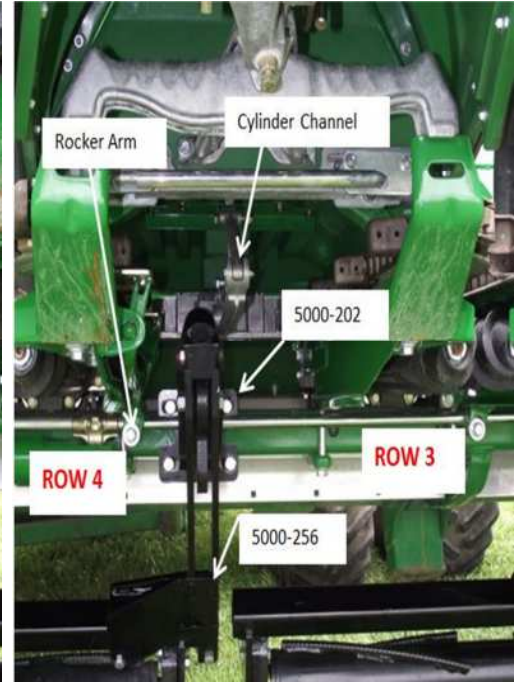

Row 5 & 6



Row 6 & 7

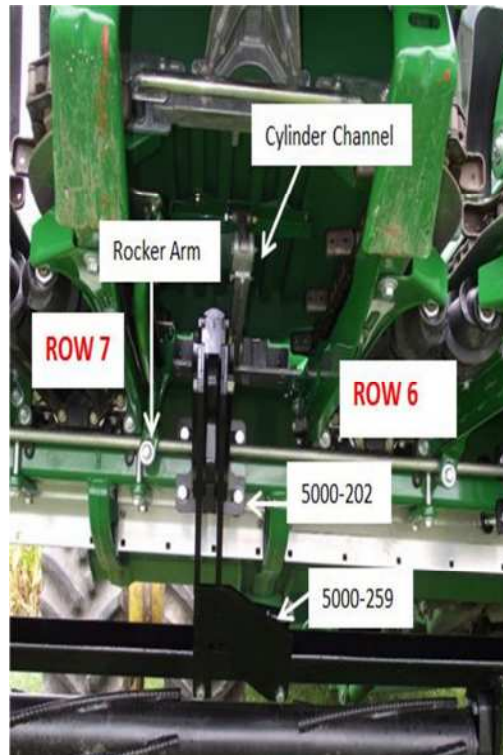

Row 7 & 8





# 5000-028A ASSEMBLY INSTRUCTIONS

**Step 6:** Secure the mounting bracket installed in **Step 1** at this time by tightening the 5/8 X 6" bolts & 5/8 lock nuts. Make sure the compression spring clears the cylinder channel as well as the rocker arm of the deck plate adjustment. The offset pivot arm clamp should be under the snout, not directly under the row.

Row 9 & 10

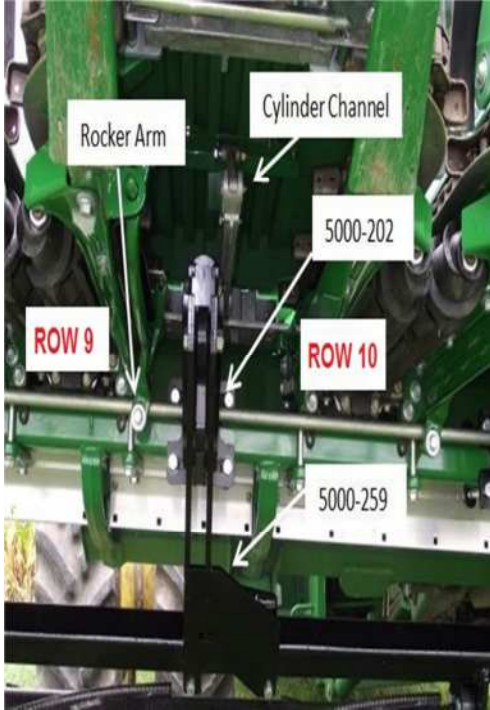

Row 10 & 11



Row 11 & 12

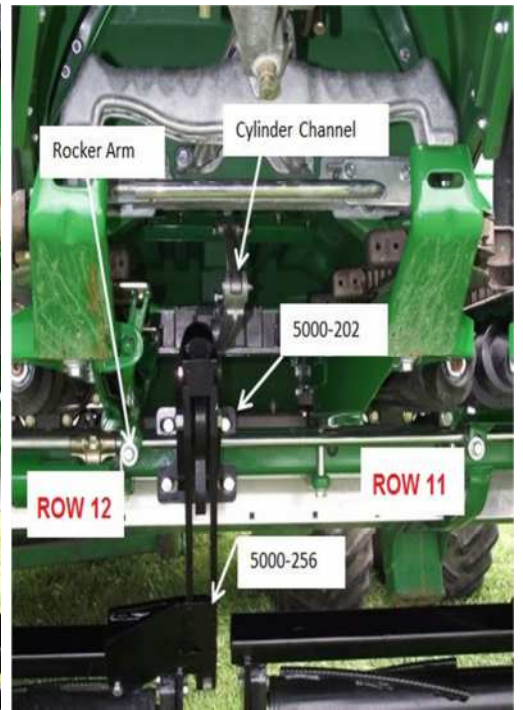

Row 13 & 14

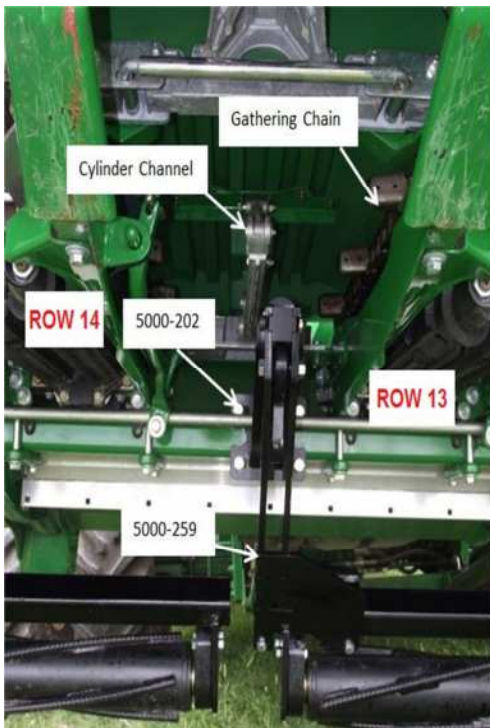

Row 14 & 15

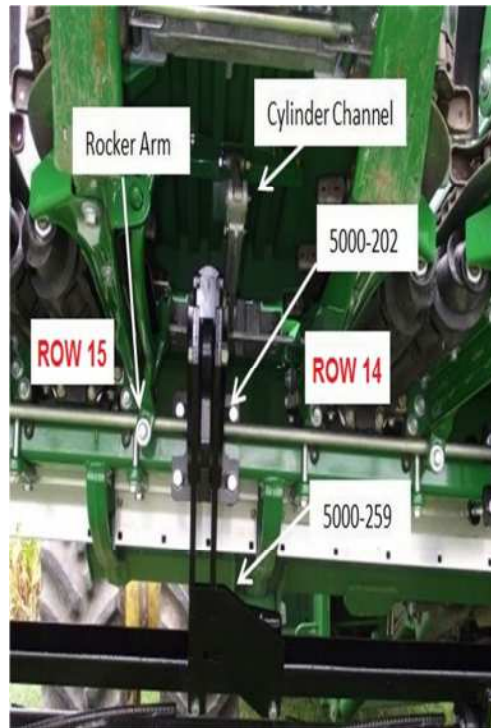

Row 15 & 16



# 5000-028A ASSEMBLY INSTRUCTIONS

**Step 7:** Install the Roller Arm Mount Tube inside the clamp channel of the pivot arms using the 5000-138 bolt bag. Do not tighten this hardware until after the rollers have been installed in **Step 8**.

**NOTE:** Install the 2 & 3 row Roller Arm Mount Tube on so that the bearing support tab is on the back side to help support the bearings.

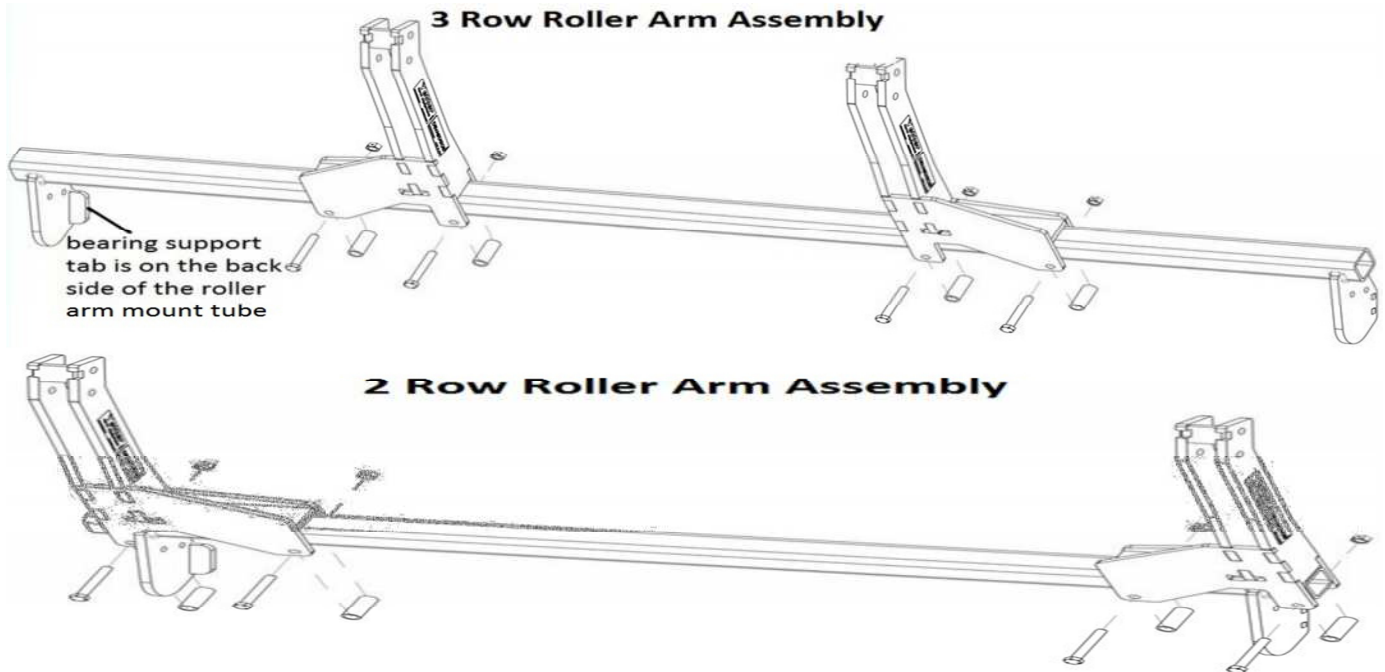

**Step 8:** Insert the shim washer over the shaft on each end of the roller. Install the bearing over the shaft on each end of the roller so that the side of the casting that has the bearing protruding past the housing surface is towards the roller barrel & shim washer. Lift each roller into place, traction bar in front of the rebar, so that the bolt holes on the cast line up with the mounting tabs on the roller arm mount tube. Install the 1/2" X 2 1/2" bolts and tighten the 1/2" lock nuts. Once the roller & bearing hardware is fastened, spin the roller to ensure the bearing was installed correctly. If the roller was installed incorrectly, the roller will not spin or will have drag. Slide the roller mount tube to gain clearance on each end of the corn head & then tighten the hardware from **Step 7**. The traction bars DO NOT have to be directly under the row.

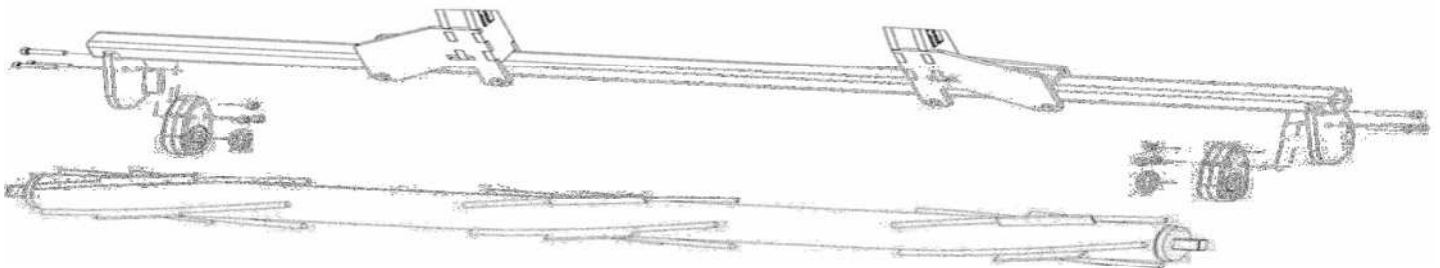

THE SIDE OF THE BEARING ASSEMBLY WHERE THE BEARING IS PROTRUDING MUST BE INSTALLED TOWARD THE ROLLER!

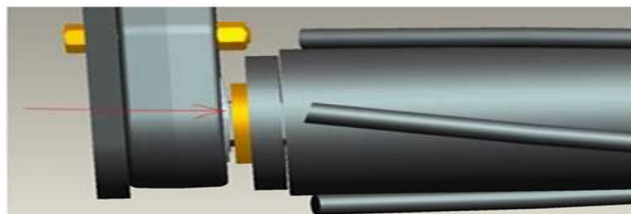



# 5000-034 ASSEMBLY INSTRUCTIONS

(JD 612FC & 712FC)

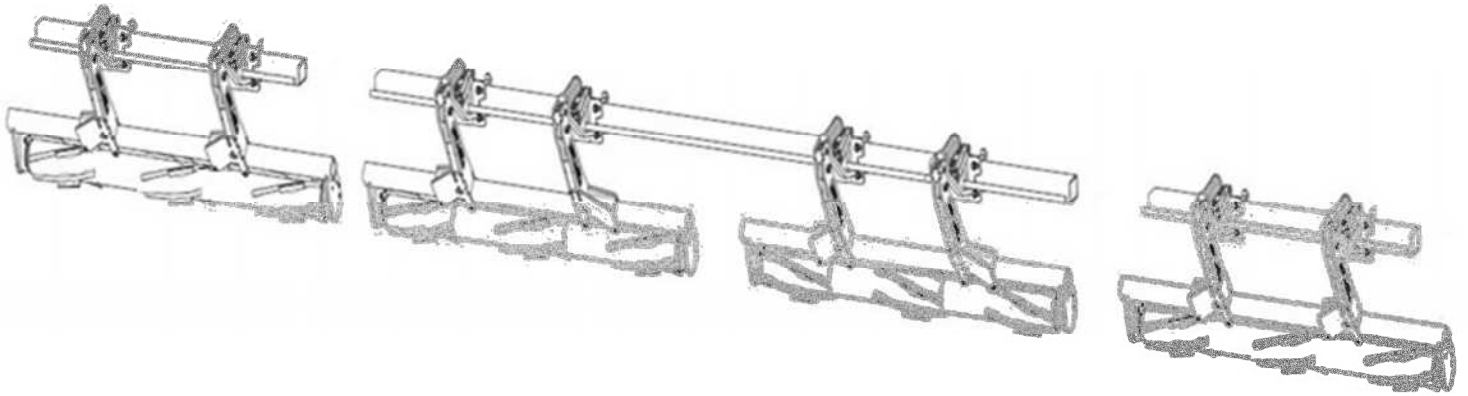

**Step 1:** Attach the 5000-202 mount brackets to the frame between rows 4 & 5, 5 & 6, 7 & 8, and 8 & 9 using the 5/8 x 6 bolts, mounting straps, & 5/8" lock hex nuts. Attach the 5000-263 mount brackets to the frame between rows 1 & 2, 2 & 3, 10 & 11, and 11 & 12. The 5000-263 mounts between rows 1 & 2 and 2 & 3 will use 5/8 X 6 bolts, mounting straps, & 5/8" lock nuts. The 5000-263 mounts between rows 10 & 11 and 11 & 12 will each use 3) 5/8 X 6 bolts & 1) 5/8 X 6 Carriage bolts (1 used on the top left of each mount on these rows), mounting straps, and 5/8" lock nuts. Slide the mount bracket up so the deck plate adjustment rod is located in the cut out of the mount bracket.

**Note:** Do not fully tighten hardware until **Step 6** after all of the pivot arms & springs are installed.

## 6 Center Rows

## Outside 3 Rows

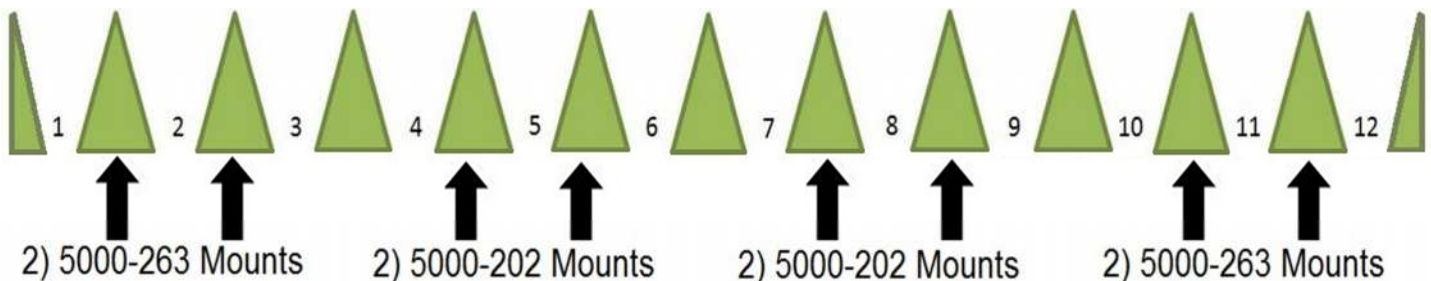
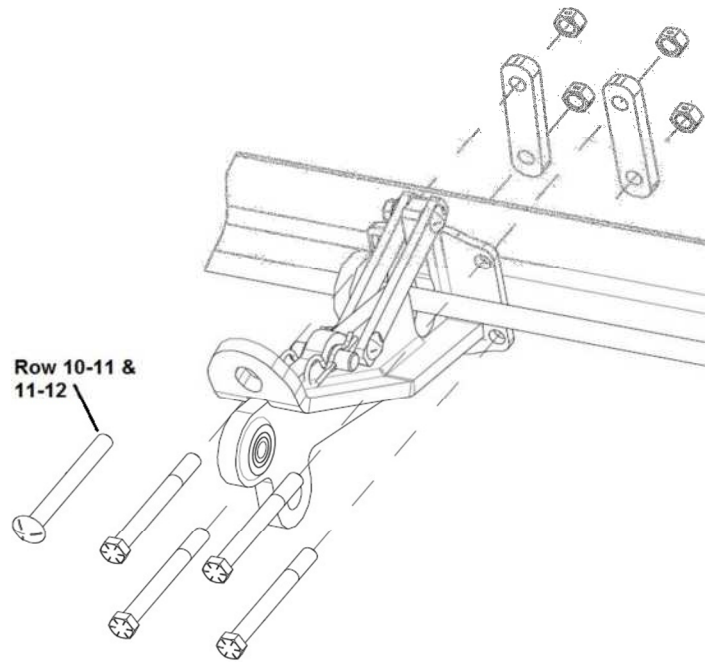
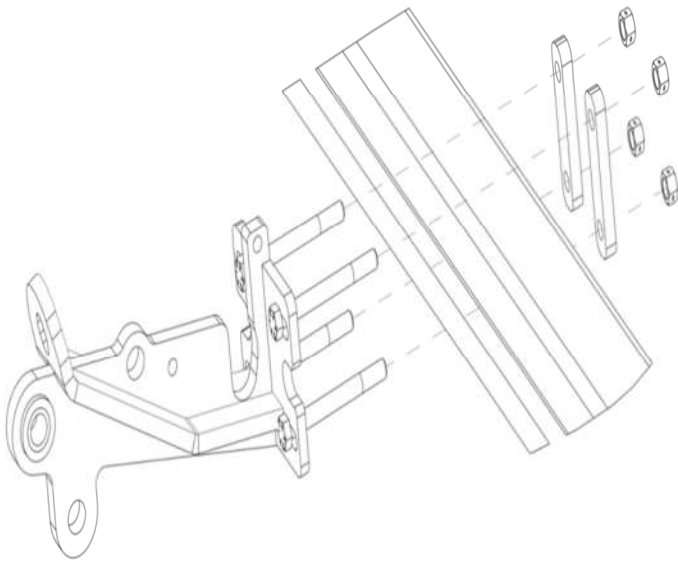

# 5000-034 ASSEMBLY INSTRUCTIONS

**Step 2:** Attach the 5000-309 support straps using 1/2" x 2" carriage bolts & 1/2" flange lock nuts, tighten.

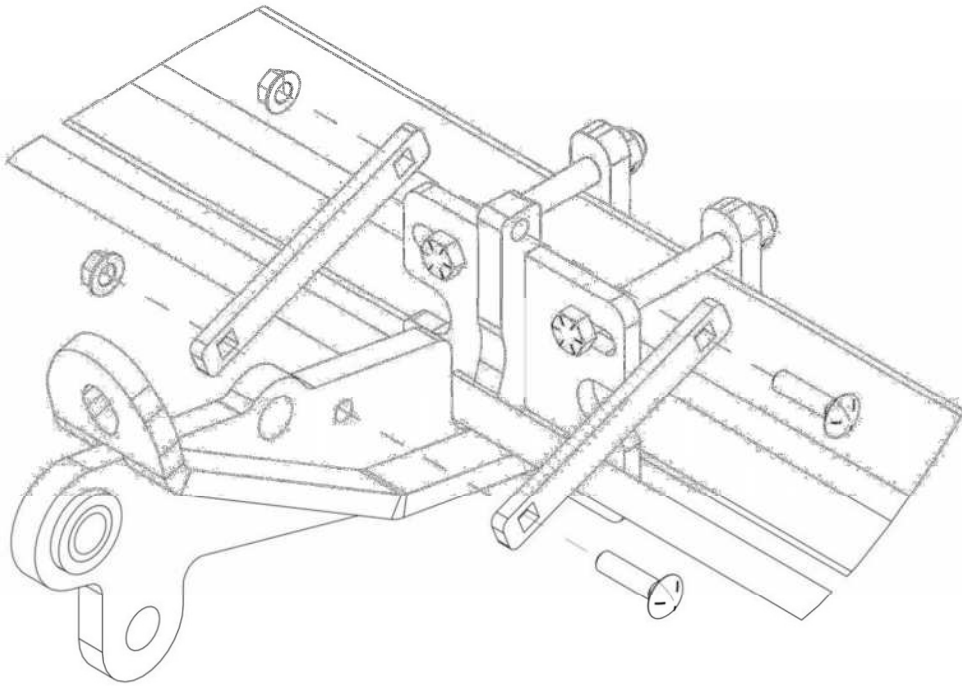

**Step 3:** Install the 5000-323 lock-up pin in the storage location on the mount brackets. Secure with the hairpin clips.

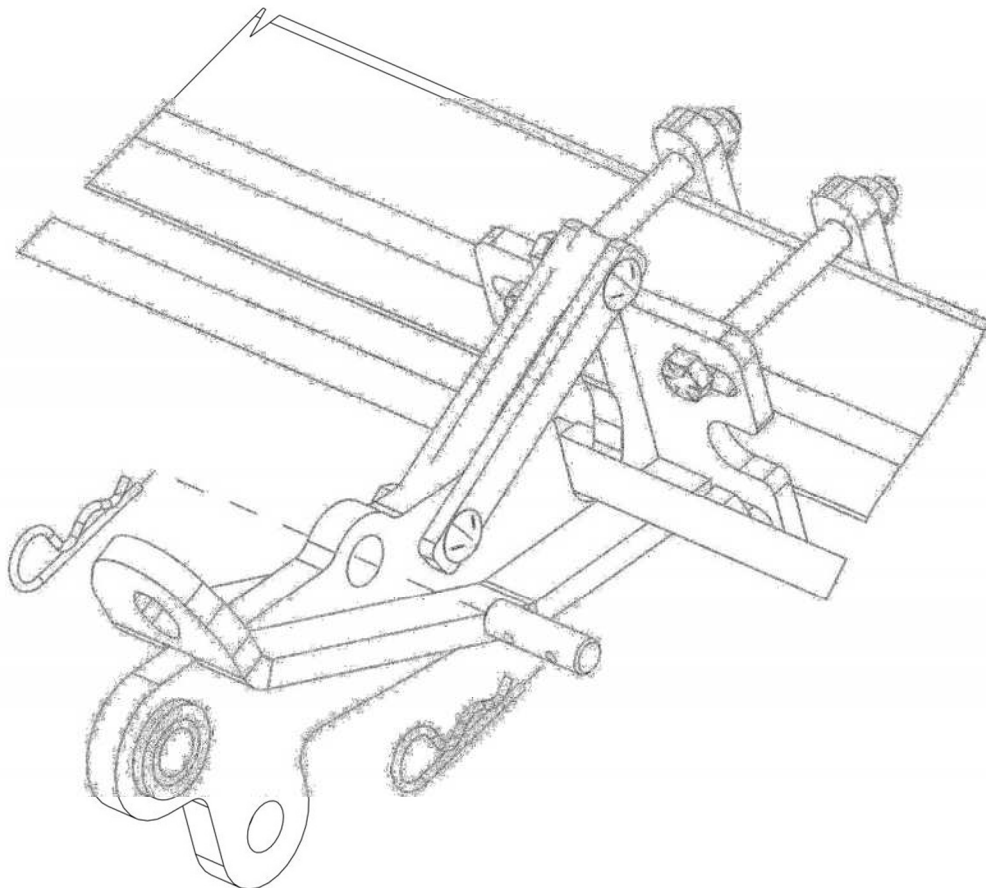

# 5000-034 ASSEMBLY INSTRUCTIONS

**Step 4:** Attach the pivot arms to the mount brackets using 5/8" X 3" bolts, pivot bushings, & 5/8" lock hex nuts. Use the model below to determine where the LH & RH pivot arms get installed. Tighten this hardware.

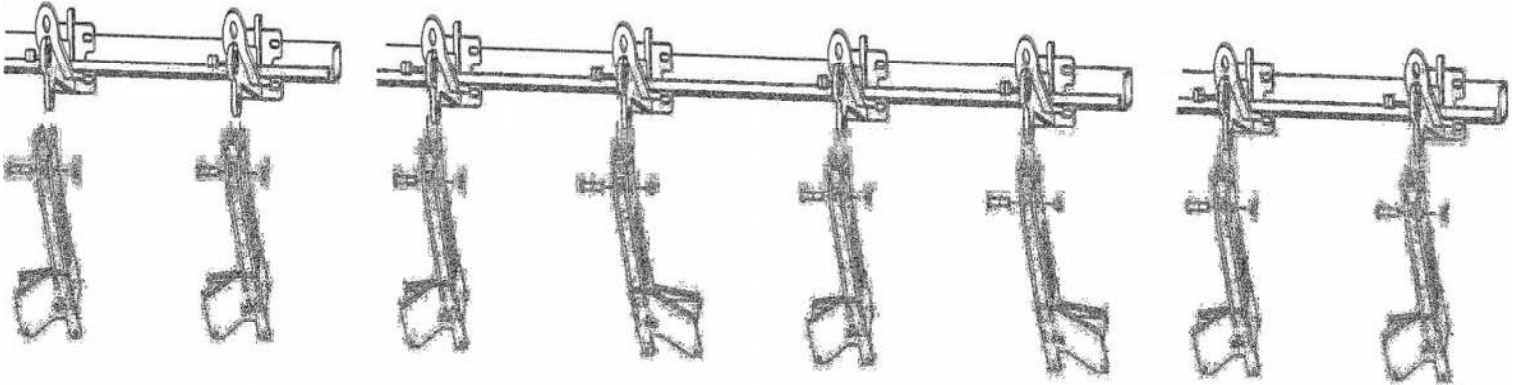

**Step 5:** Install the push rods into the mount brackets then attach to the pivot arms with the 5/8" shoulder bolts, washers, and 1/2" jam lock nuts.

**Note:** The washers are installed on each side of the "eye" of the push rod.

Now install the compression spring, spring bushing, and 3/4" lock hex nuts. The 5000-402 wedge will need installed between the compression spring and the mount bracket between rows 1 & 2 and 2 & 3 to keep the spring from contacting the gathering chains. Tighten the hardware from **Step 5** to the specification in the diagram below.

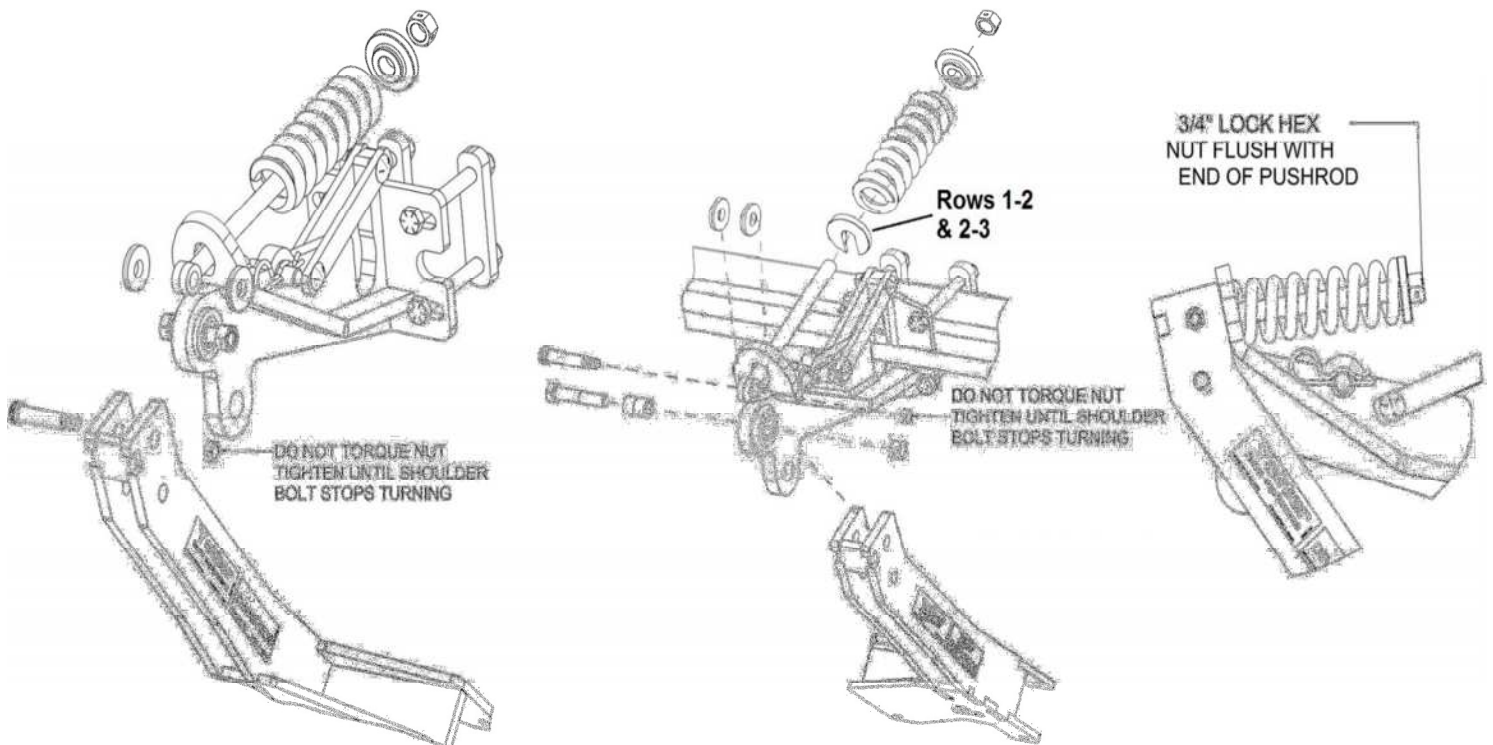

**NOTE:** Tightening the nut on the spring bushing more will result in added down pressure. However, DO NOT tighten the nut on the spring bushing down so far that spring compression limits pivot arm travel. This will cause the spring to break, especially if spring is compression all off-season.



# 5000-034 ASSEMBLY INSTRUCTIONS

Row 1 & 2 and 2 & 3

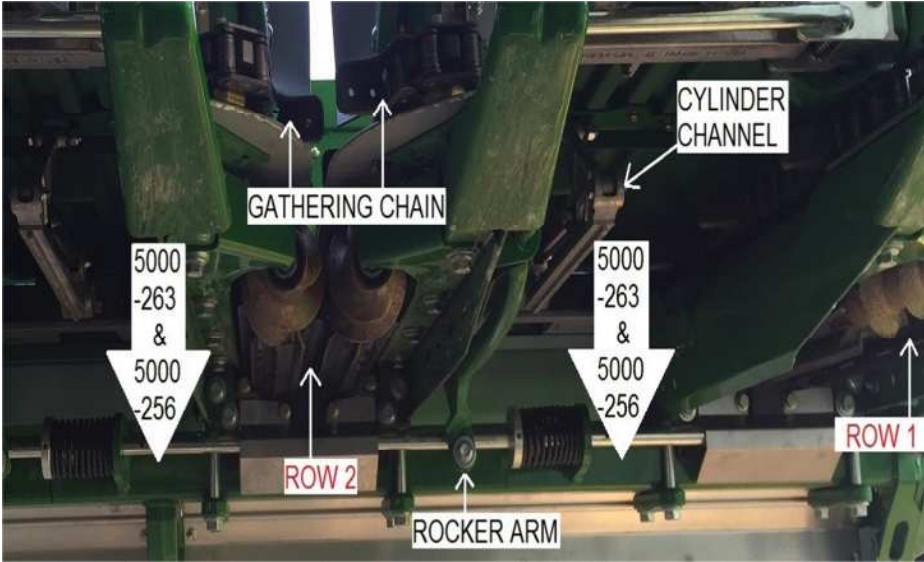

Row 4 & 5

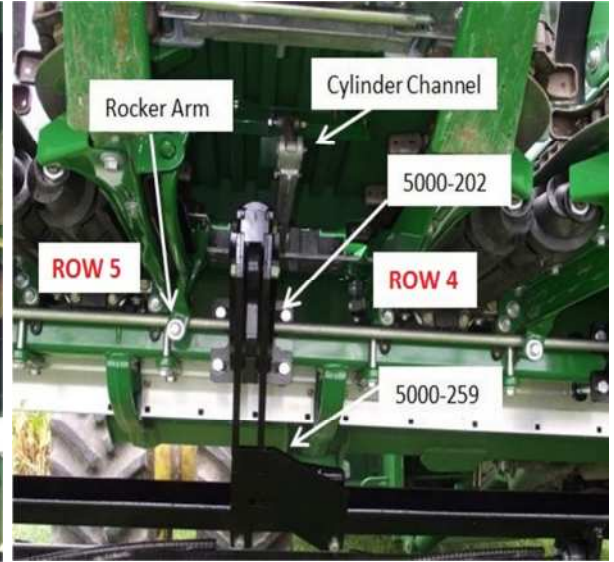

Row 5 & 6

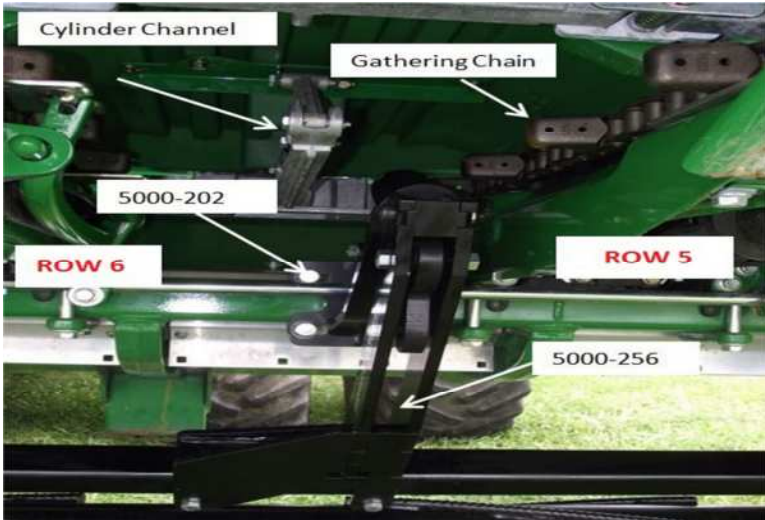

Row 7 & 8

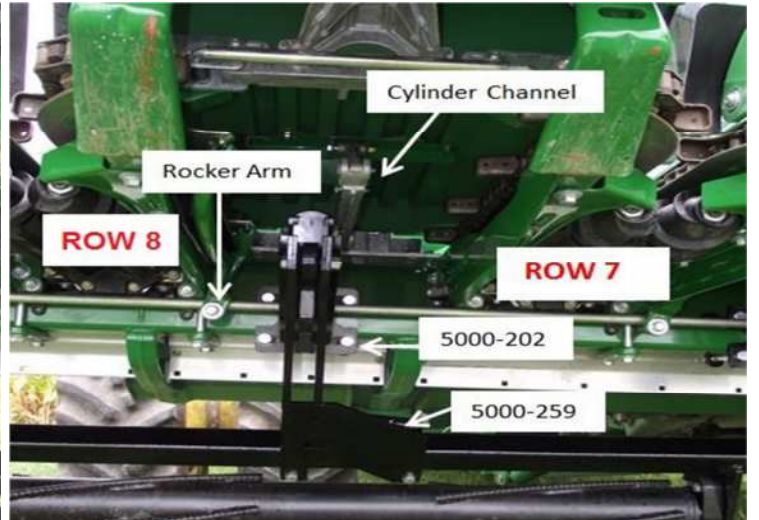

Row 8 & 9

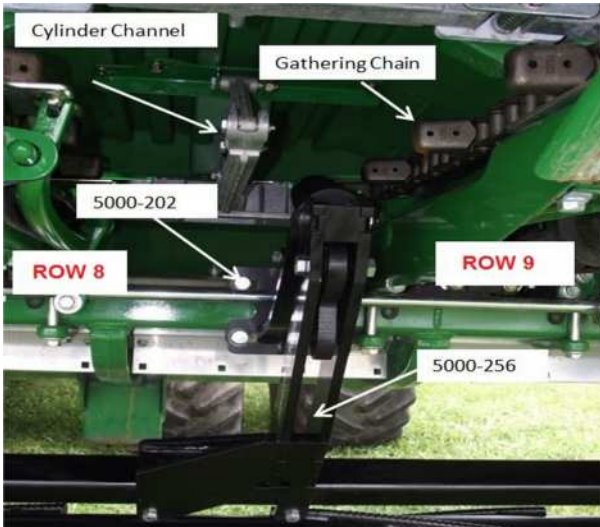

Row 10 & 11 and 11 & 12

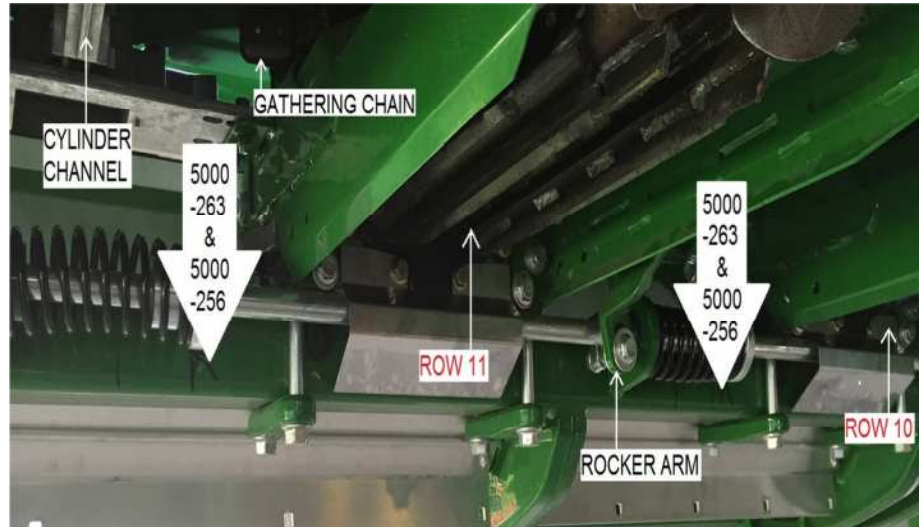

# 5000-034 ASSEMBLY INSTRUCTIONS

**Step 7:** Install the Roller Arm Mount Tube inside the clamp channel of the pivot arms using the 5000-138 bolt bag. Do not tighten this hardware until after the rollers have been installed in **Step 8**.

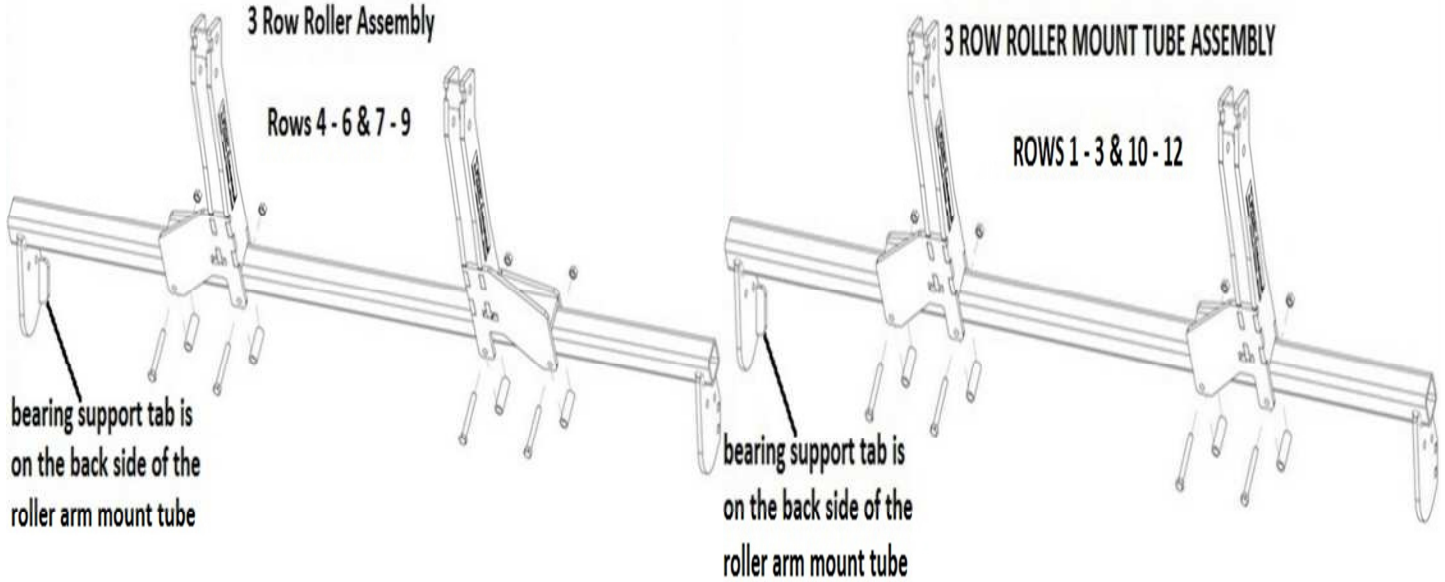

**Step 8:** Insert the shim washer over the shaft on each end of the roller. Install the bearing over the shaft on each end of the roller so that the side of the casting that has the bearing protruding past the housing surface is towards the roller barrel & shim washer. Lift each roller into place, traction bar in front of the rebar, so that the bolt holes on the cast line up with the mounting tabs on the roller arm mount tube. Install the 1/2" X 2 1/2" bolts and tighten the 1/2" lock nuts. Once the roller & bearing hardware is fastened, spin the roller to ensure the bearing was installed correctly. If the roller was installed incorrectly, the roller will not spin or will have drag. Slide the roller mount tube to gain clearance on each end of the corn head & then tighten the hardware from **Step 7**. The traction bars DO NOT have to be directly under the row.

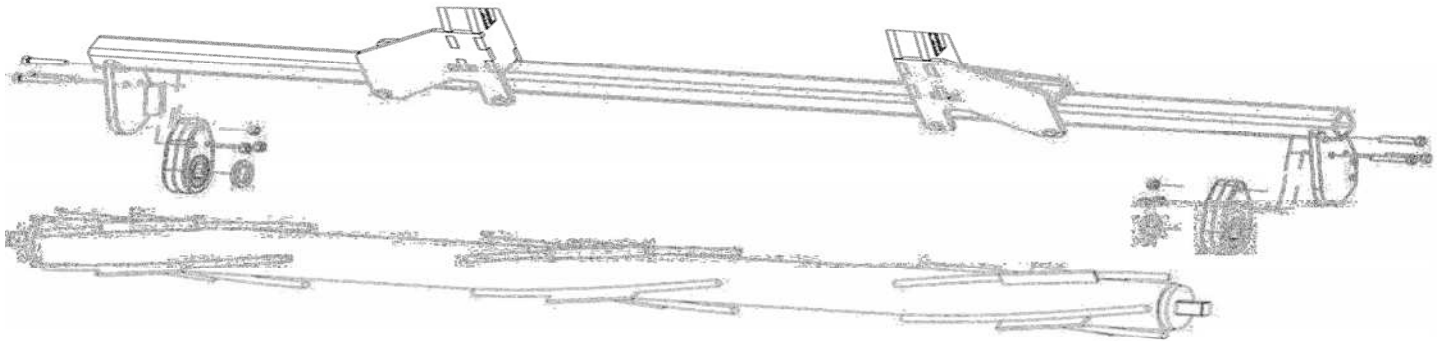

THE SIDE OF THE BEARING ASSEMBLY WHERE THE BEARING IS PROTRUDING MUST BE INSTALLED TOWARD THE ROLLER!

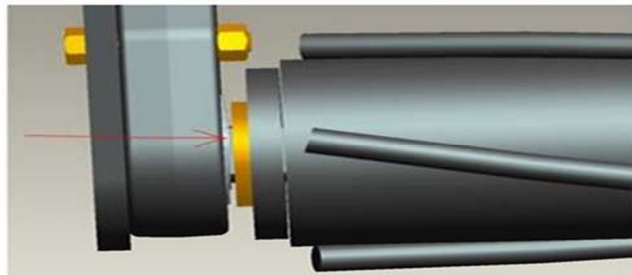



# OPERATION

**CORN HEAD ANGLE SHOULD BE BETWEEN 23 – 25° FOR OPTIMUM DEVASTATOR PERFORMANCE.**

USE THE 5000-455 TO CHECK CORN HEAD ANGLE:

- Put the combine on a level surface. Lower the Corn head to your normal working head height.
- Place the magnetic protractor on the stripper plate to get the angle. Adjust the feeder house as needed, fore or aft, to achieve 23 – 25 degrees.



# BEARING REPLACEMENT

Put the bearing housing in a vice, use a pry bar to turn the bearing in the housing parallel with the slots, remove the old bearing, apply anti-seize lubricant to the interior of the bearing housing, insert the new bearing in the slots, & use a pry bar to move back to position. Wobble the bearing around to help work the lubricant into the outer race of the bearing.



# STORAGE

When storing the corn head for the offseason, it is OK for the 5000 Stalk Devastators to hold some weight of the corn head whether stored on the ground or on a trailer. Removing compression springs may help extend the service life.

# LOCKING UP THE 5000 SERIES STALK DEVASTATOR

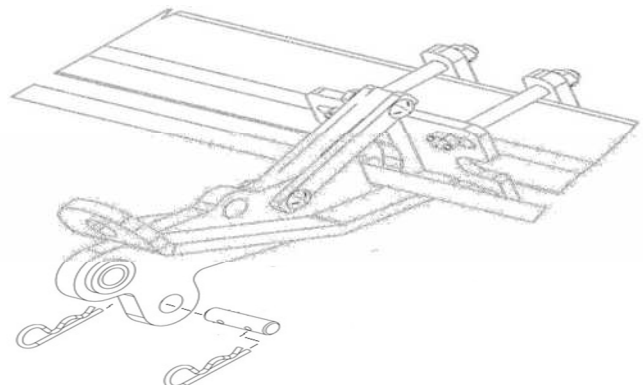

# 5000-025A 6 ROW PART IDENTIFICATION

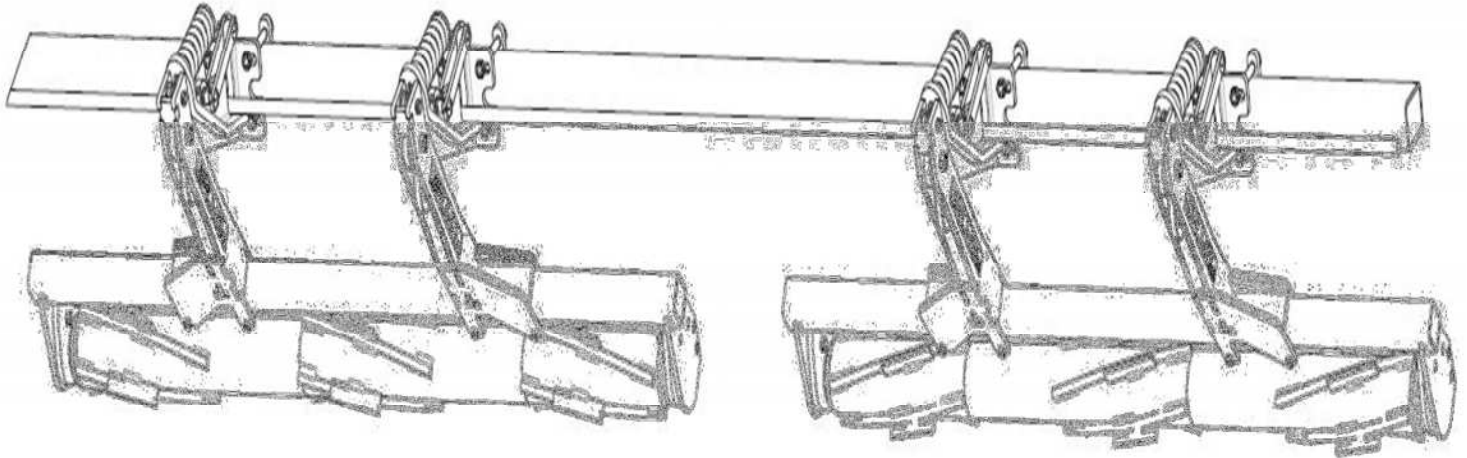

ITEM	PART #	DESCRIPTION	QTY
1	2502-325	5/8 – 11 X 3 HHCS GR 5 ZP	4
2	2502-352	5/8 – 11 X 6 HHCS GR 5 ZP	16
3	2502-353	1/2 – 13 X 2-1/2 HHCS GR 8	12
4	2502-365	1/2 – 13 X 3-3/4 HHCS GR 5	8
5	2505-345	1/2 – 13 X 2 CARRIAGE BOLT GR 5 ZP	8
6	2510-121	5/8 DIAMETER SHOULDER BOLT, 2-1/4 SHOULDER, 1/2 – 13	4
7	2520-357	1/2 - 13 LOCK HEX NUT, GR A, ZP	20
8	2520-361	1/2 - 13 FLANGE WHIZ LOCK HEX NUT, GR 5, ZP	8
9	2520-364	1/2 -13 JAM LOCK HEX NUT	4
10	2520-459	5/8 – 11 LOCK HEX NUT, GR B, ZP	20
11	2520-515	3/4 - 10 LOCK HEX NUT, GR A, ZP	4
12	2526-449	5/8 FLAT WASHER, 1/4 THICK, ZP	8
13	2550-709	1/2 WIRE 2-1/2 OD X 1-1/2 ID X 7-1/4 COMPRESSION SPRING	4
14	2570-126	3/4 X 10 EYEBOLT, ZP	4
15	2570-465	7 GAUGE HAIRPIN COTTER ZP	8
16	2975-302	2975 SPRING BUSHING "PAINTED"	4
17	5000-202	MOUNT BRACKET W.A., SINGLE	4
	2528-369	1.380 OD X 1.00 ID X 1.25 L BEARING SLEEVE	
18	5000-309	SUPPORT STRAP	8
19	5000-318	PIVOT BUSHING	4
20	5000-319	MOUNT STRAP 3"	8
21	5000-322	SHIM WASHER ZP	4
22	5000-323	LOCK UP PIN ZP	4
23	5000-355	1-1/4 DISC HARROW BEARING, W209PPB5, HD ASSEMBLY	4
	2550-059	DEVASTATOR BEARING ONLY (NO CAST HOUSING)	
24	5000-378	SPACER BUSHING	8
25	5000-211A	ROLLER W.A., LH, 76"	1
26	5000-212A	ROLLER W.A., RH, 76"	1
27	5000-254	ROLLER MOUNT 3 ROW	2
28	5000-256	OVER BEARING ARM 19" LH	2
29	5000-259	OVER BEARING ARM 19" RH	2



# 5000-025A 6 ROW PART IDENTIFICATION

\*SEE PREVIOUS PAGE FOR PART NUMBER REFERENCE\*

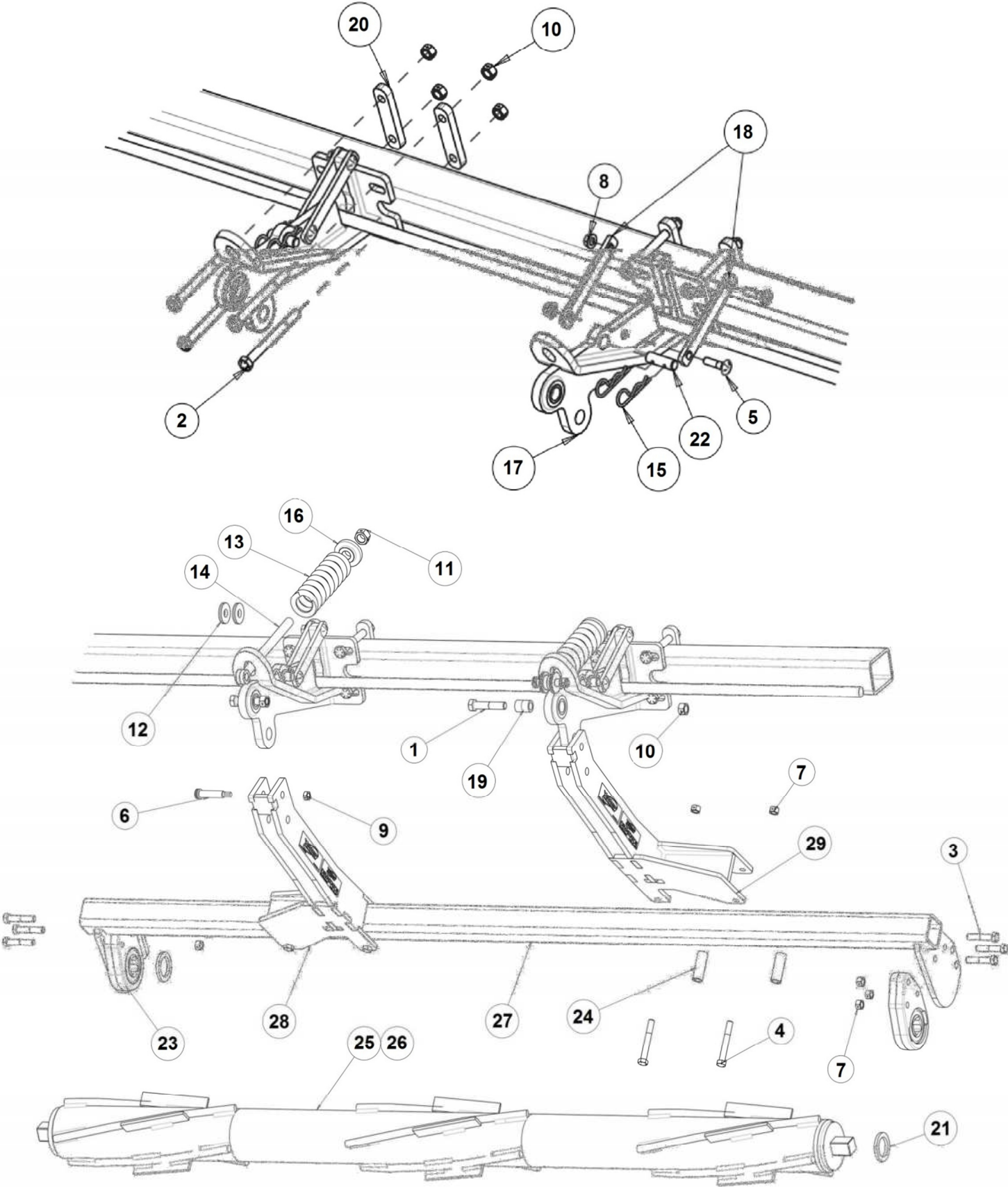

# 5000-026A 8 ROW PART IDENTIFICATION

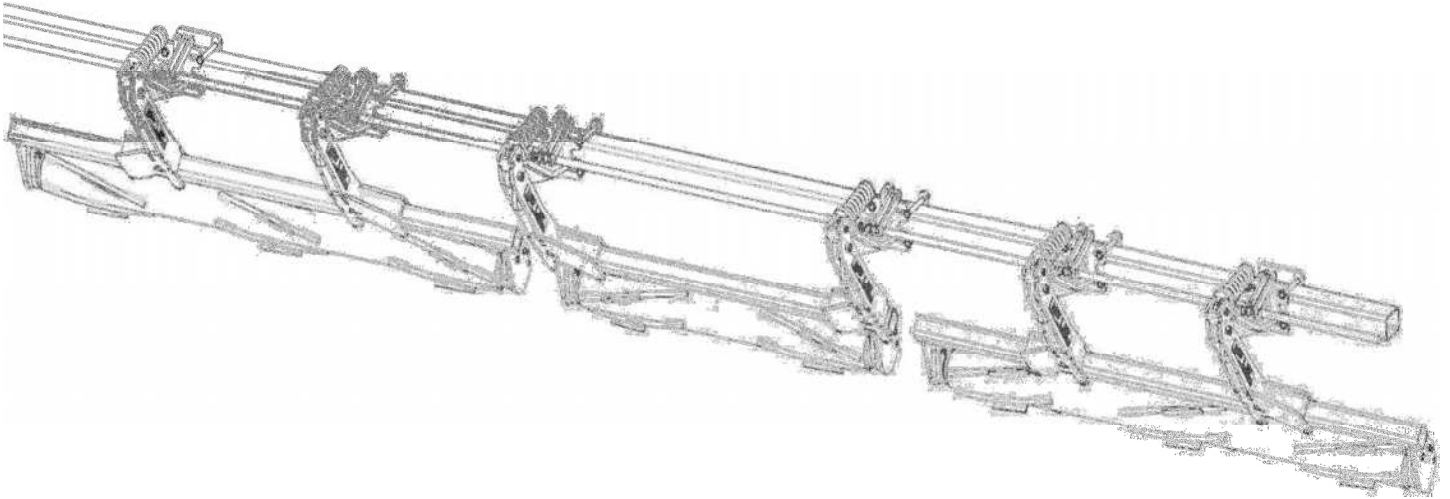

ITEM	PART #	DESCRIPTION	QTY
1	2502-325	5/8 – 11 X 3 HHCS GR 5 ZP	6
2	2502-352	5/8 – 11 X 6 HHCS GR 5 ZP	24
3	2502-353	1/2 – 13 X 2-1/2 HHCS GR 8	18
4	2502-365	1/2 – 13 X 3-3/4 HHCS GR 5	12
5	2505-345	1/2 – 13 X 2 CARRIAGE BOLT GR 5 ZP	12
6	2510-121	5/8 DIAMETER SHOULDER BOLT, 2-1/4 SHOULDER, 1/2 – 13	6
7	2520-357	1/2 - 13 LOCK HEX NUT, GR A, ZP	30
8	2520-361	1/2 - 13 FLANGE WHIZ LOCK HEX NUT, GR 5, ZP	12
9	2520-364	1/2 -13 JAM LOCK HEX NUT	6
10	2520-459	5/8 – 11 LOCK HEX NUT, GR B, ZP	30
11	2520-515	3/4 - 10 LOCK HEX NUT, GR A, ZP	6
12	2526-449	5/8 FLAT WASHER, 1/4 THICK, ZP	12
13	2550-709	1/2 WIRE 2-1/2 OD X 1-1/2 ID X 7-1/4 COMPRESSION SPRING	6
14	2570-126	3/4 X 10 EYEBOLT, ZP	6
15	2570-465	7 GAUGE HAIRPIN COTTER ZP	12
16	2975-302	2975 SPRING BUSHING "PAINTED"	6
17	5000-202	MOUNT BRACKET W.A., SINGLE	6
	2528-369	1.380 OD X 1.00 ID X 1.25 L BEARING SLEEVE	
18	5000-203A	ROLLER W.A. 48"	1
19	5000-211A	ROLLER W.A., LH, 76"	1
20	5000-212A	ROLLER W.A., RH, 76"	1
21	5000-254	ROLLER MOUNT 3 ROW	2
22	5000-255	ROLLER MOUNT W.A.	1
23	5000-256	OVER BEARING ARM 19" LH	3
24	5000-259	OVER BEARING ARM 19" RH	3
25	5000-309	SUPPORT STRAP	12
26	5000-318	PIVOT BUSHING	6
27	5000-319	MOUNT STRAP 3"	12
28	5000-322	SHIM WASHER ZP	6
29	5000-323	LOCK UP PIN ZP	6
30	5000-355	1-1/4 DISC HARROW BEARING, W209PPB5, HD ASSEMBLY	6
	2550-059	DEVASTATOR BEARING ONLY (NO CAST HOUSING)	
31	5000-378	SPACER BUSHING	12
32	5000-301	"L" MOUNT PLATE FOR 90 SERIES ONLY	2

# 5000-026A 8 ROW PART IDENTIFICATION

\*SEE PREVIOUS PAGE FOR PART NUMBER REFERENCE\*

For use on rows 1-2 & 7-8 on 893

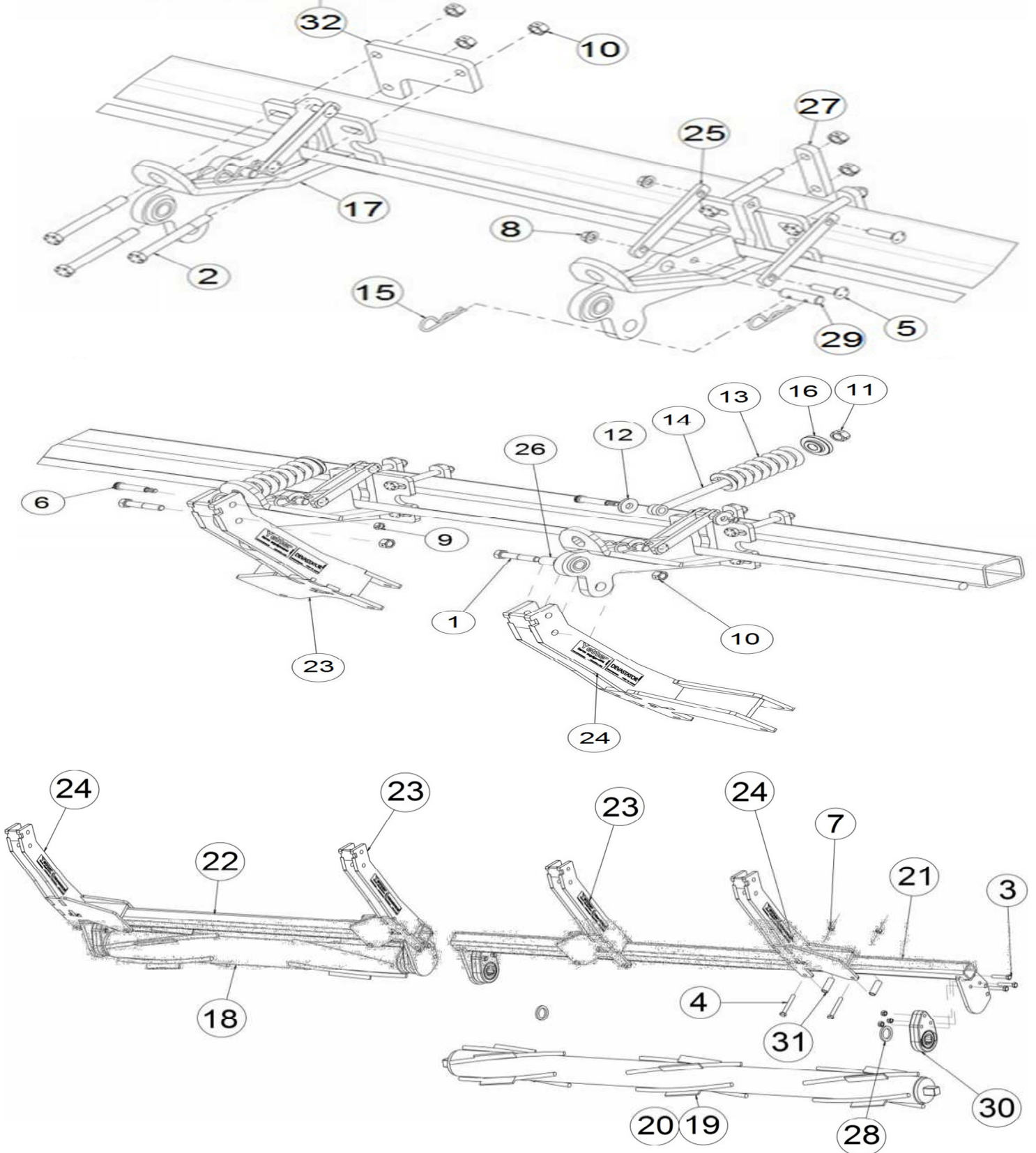

# 5000-027A 12 ROW PART IDENTIFICATION

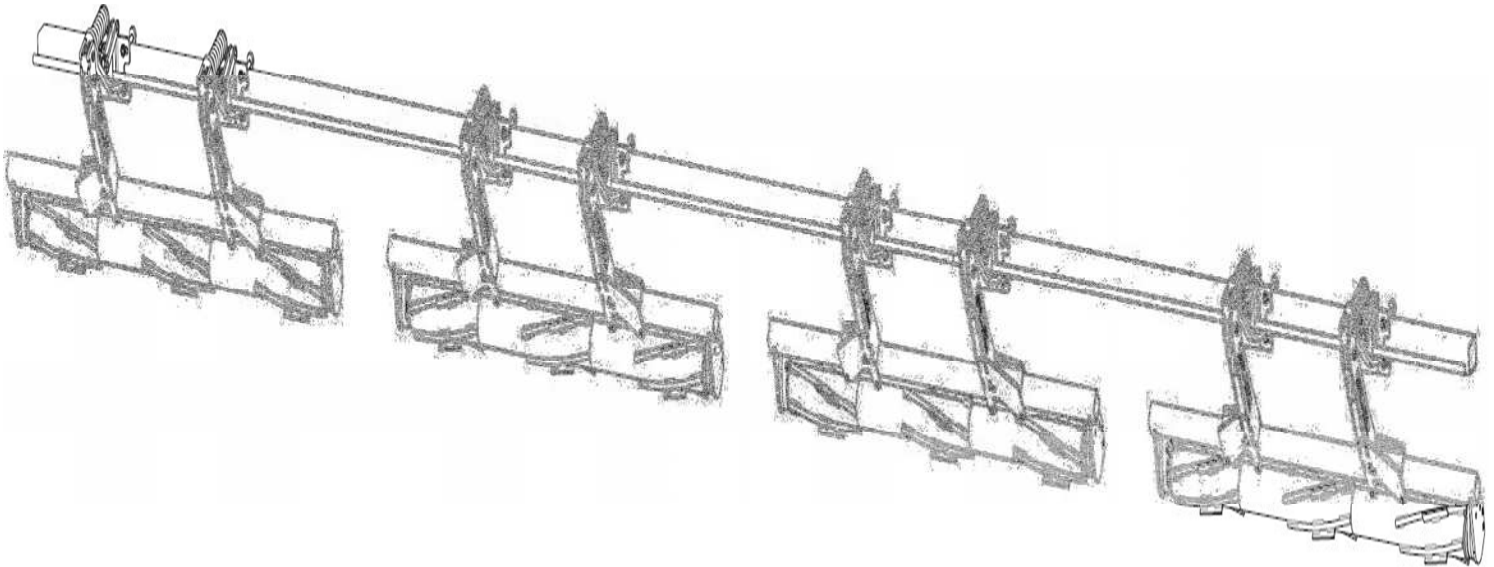

ITEM	PART #	DESCRIPTION	QTY
1	2502-325	5/8 – 11 X 3 HHCS GR 5 ZP	8
2	2502-352	5/8 – 11 X 6 HHCS GR 5 ZP	32
3	2502-353	1/2 – 13 X 2-1/2 HHCS GR 8	24
4	2502-365	1/2 – 13 X 3-3/4 HHCS GR 5	16
5	2505-345	1/2 – 13 X 2 CARRIAGE BOLT GR 5 ZP	16
6	2510-121	5/8 DIAMETER SHOULDER BOLT, 2-1/4 SHOULDER, 1/2 – 13	8
7	2520-357	1/2 - 13 LOCK HEX NUT, GR A, ZP	40
8	2520-361	1/2 - 13 FLANGE WHIZ LOCK HEX NUT, GR 5, ZP	16
9	2520-364	1/2 -13 JAM LOCK HEX NUT	8
10	2520-459	5/8 – 11 LOCK HEX NUT, GR B, ZP	40
11	2520-515	3/4 - 10 LOCK HEX NUT, GR A, ZP	8
12	2526-449	5/8 FLAT WASHER, 1/4 THICK, ZP	16
13	2550-709	1/2 WIRE 2-1/2 OD X 1-1/2 ID X 7-1/4 COMPRESSION SPRING	8
14	2570-126	3/4 X 10 EYEBOLT, ZP	8
15	2570-465	7 GAUGE HAIRPIN COTTER ZP	16
16	2975-302	2975 SPRING BUSHING "PAINTED"	8
17	5000-202	MOUNT BRACKET W.A., SINGLE	8
	2528-369	1.380 OD X 1.00 ID X 1.25 L BEARING SLEEVE	
18	5000-309	SUPPORT STRAP	16
19	5000-318	PIVOT BUSHING	8
20	5000-319	MOUNT STRAP 3"	16
21	5000-322	SHIM WASHER ZP	8
22	5000-323	LOCK UP PIN ZP	8
23	5000-355	1-1/4 DISC HARROW BEARING, W209PPB5, HD ASSEMBLY	8
	2550-059	DEVASTATOR BEARING ONLY (NO CAST HOUSING)	
24	5000-378	SPACER BUSHING	16
25	5000-211A	ROLLER W.A., LH, 76"	2
26	5000-212A	ROLLER W.A., RH, 76"	2
27	5000-254	ROLLER MOUNT 3 ROW	4
28	5000-256	OVER BEARING ARM 19" LH	4
29	5000-259	OVER BEARING ARM 19" RH	4
30	5000-301	"L" MOUNT PLATE FOR 90 SERIES ONLY	2



# 5000-027A 12 ROW PART IDENTIFICATION

**\*SEE PREVIOUS PAGE FOR PART NUMBER REFERENCE\***

FOR USE ON ROWS 2-3 & 10-11 ON 1293

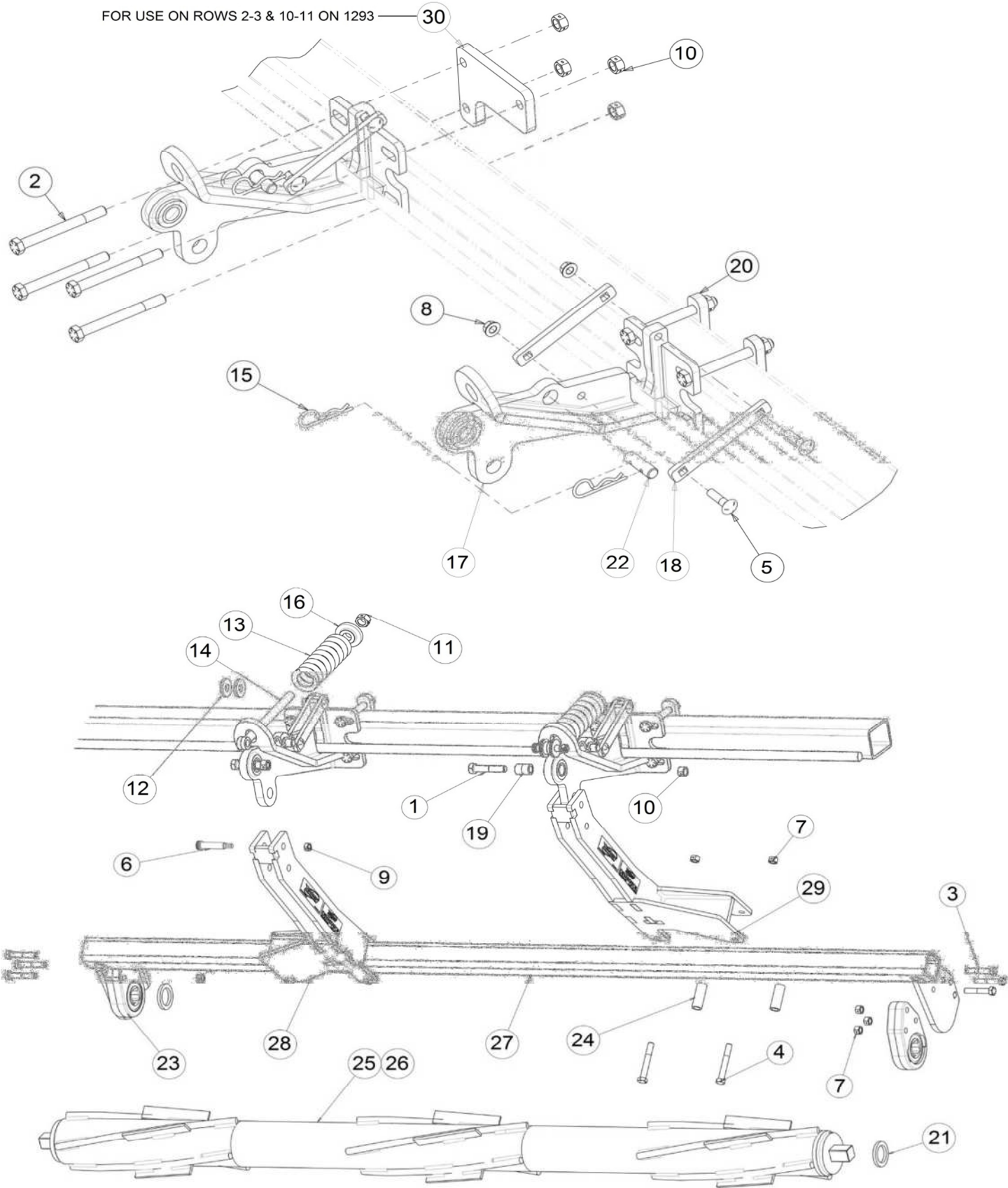

# 5000-028A 16 ROW PART IDENTIFICATION

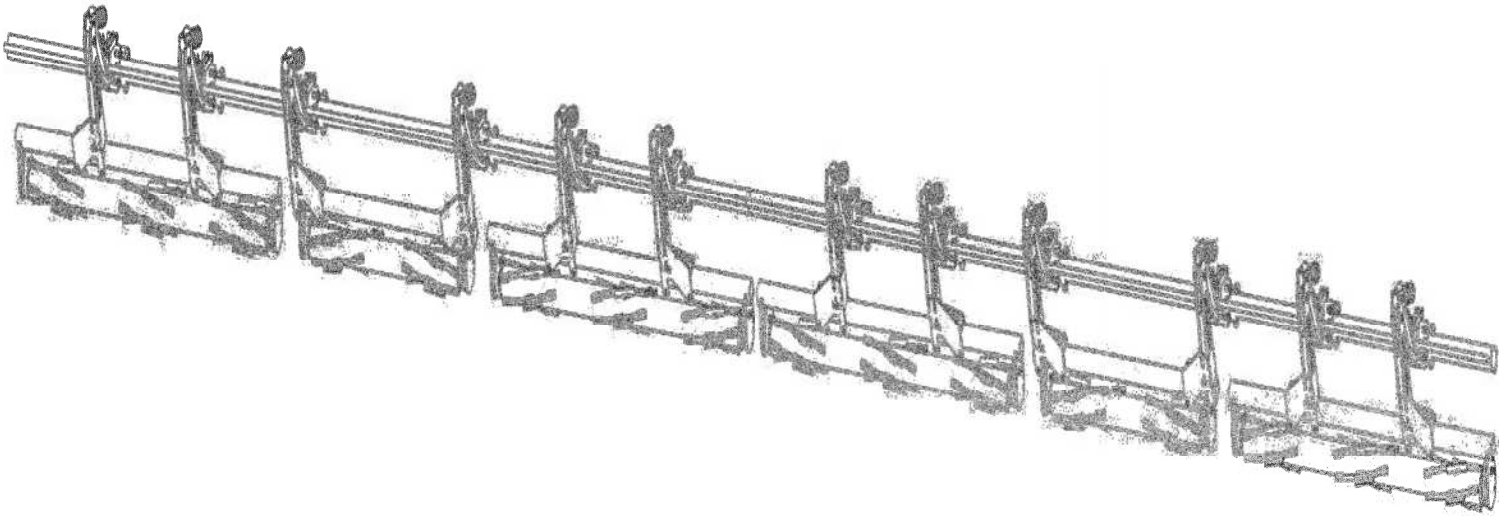

ITEM	PART #	DESCRIPTION	QTY
1	2502-325	5/8 – 11 X 3 HHCS GR 5 ZP	12
2	2502-352	5/8 – 11 X 6 HHCS GR 5 ZP	48
3	2502-353	1/2 – 13 X 2-1/2 HHCS GR 8	36
4	2502-365	1/2 – 13 X 3-3/4 HHCS GR 5	24
5	2505-345	1/2 – 13 X 2 CARRIAGE BOLT GR 5 ZP	24
6	2510-121	5/8 DIAMETER SHOULDER BOLT, 2-1/4 SHOULDER, 1/2 – 13	12
7	2520-357	1/2 - 13 LOCK HEX NUT, GR A, ZP	60
8	2520-361	1/2 - 13 FLANGE WHIZ LOCK HEX NUT, GR 5, ZP	24
9	2520-364	1/2 -13 JAM LOCK HEX NUT	12
10	2520-459	5/8 – 11 LOCK HEX NUT, GR B, ZP	60
11	2520-515	3/4 - 10 LOCK HEX NUT, GR A, ZP	12
12	2526-449	5/8 FLAT WASHER, 1/4 THICK, ZP	24
13	2550-709	1/2 WIRE 2-1/2 OD X 1-1/2 ID X 7-1/4 COMPRESSION SPRING	12
14	2570-126	3/4 X 10 EYEBOLT, ZP	12
15	2570-465	7 GAUGE HAIRPIN COTTER ZP	24
16	2975-302	2975 SPRING BUSHING "PAINTED"	12
17	5000-202	MOUNT BRACKET W.A., SINGLE	12
	2528-369	1.380 OD X 1.00 ID X 1.25 L BEARING SLEEVE	
18	5000-203A	ROLLER W.A. 48"	2
19	5000-211A	ROLLER W.A., LH, 76"	2
20	5000-212A	ROLLER W.A., RH, 76"	2
21	5000-254	ROLLER MOUNT 3 ROW	4
22	5000-255	ROLLER MOUNT W.A.	2
23	5000-256	OVER BEARING ARM 19" LH	6
24	5000-259	OVER BEARING ARM 19" RH	6
25	5000-309	SUPPORT STRAP	24
26	5000-318	PIVOT BUSHING	12
27	5000-319	MOUNT STRAP 3"	24
28	5000-322	SHIM WASHER ZP	12
29	5000-323	LOCK UP PIN ZP	12
30	5000-355	1-1/4 DISC HARROW BEARING, W209PPB5, HD ASSEMBLY	12
	2550-059	DEVASTATOR BEARING ONLY (NO CAST HOUSING)	
31	5000-378	SPACER BUSHING	24

# 5000-028A 16 ROW PART IDENTIFICATION

\*SEE PREVIOUS PAGE FOR PART NUMBER REFERENCE\*

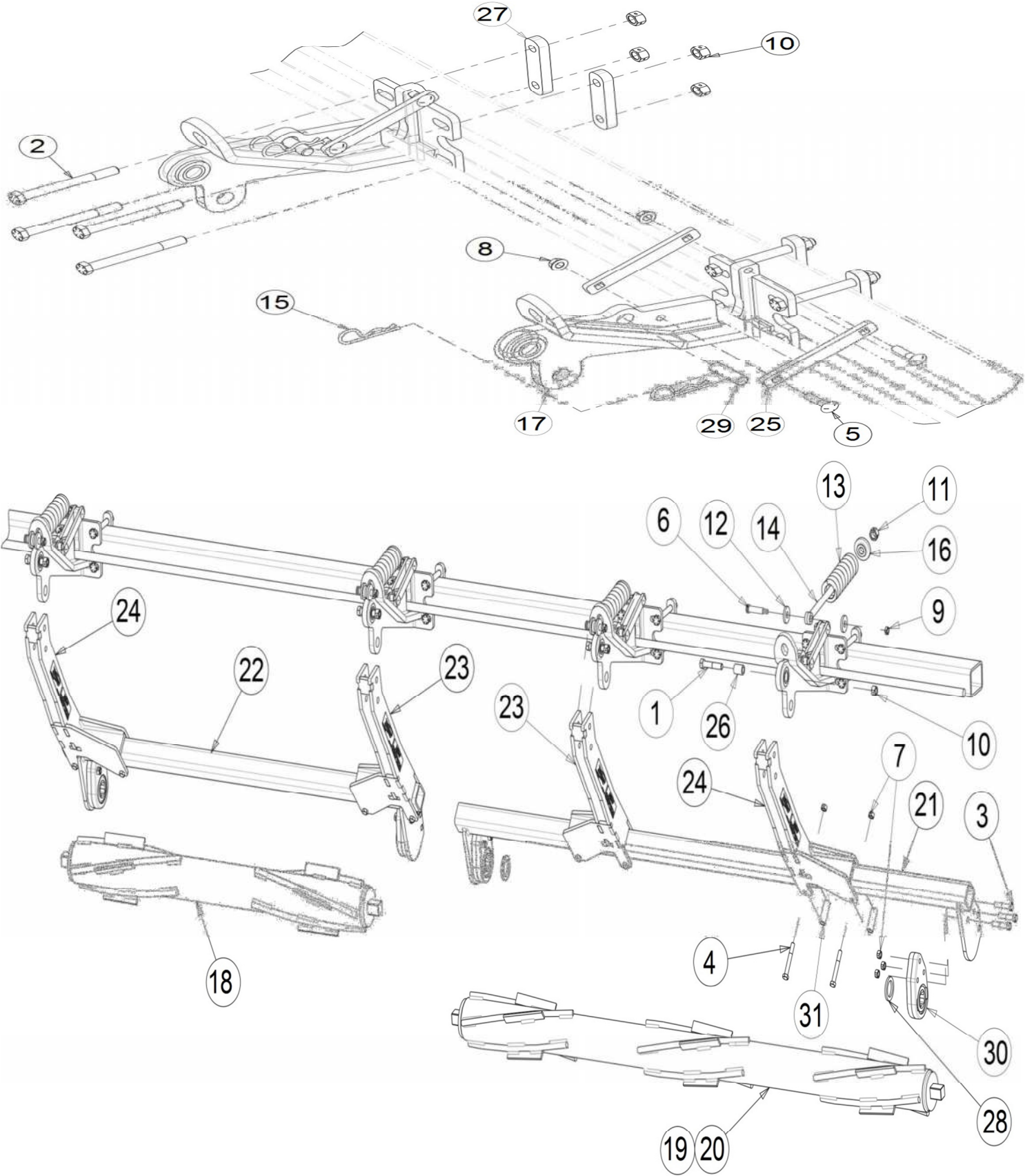

# 5000-034 12 ROW FOLDING PART IDENTIFICATION

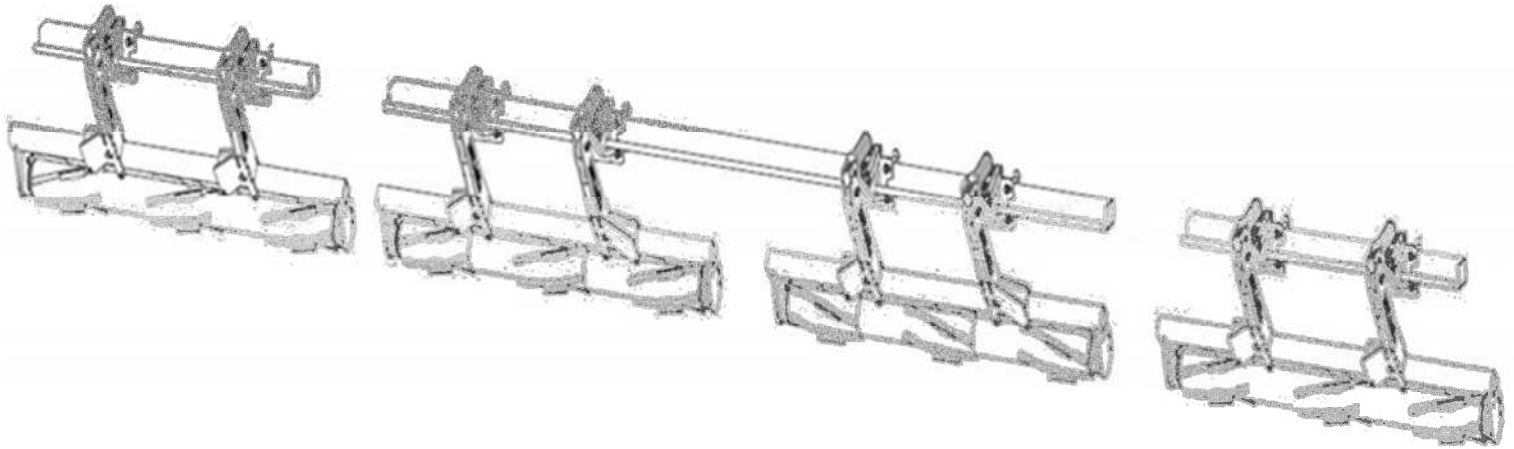

ITEM	PART #	DESCRIPTION	QTY
1	2502-325	5/8 – 11 X 3 HHCS GR 5 ZP	8
2	2502-352	5/8 – 11 X 6 HHCS GR 5 ZP	32
3	2502-353	1/2 – 13 X 2-1/2 HHCS GR 8	24
4	2502-365	1/2 – 13 X 3-3/4 HHCS GR 5	16
5	2505-345	1/2 – 13 X 2 CARRIAGE BOLT GR 5 ZP	16
6	2505-414	5/8 – 11 X 6 CARRIAGE BOLT, GR 5, ZP (used on rows 10/11 & 11/12)	2
7	2510-121	5/8 DIAMETER SHOULDER BOLT, 2-1/4 SHOULDER, 1/2 – 13	8
8	2520-357	1/2 - 13 LOCK HEX NUT, GR A, ZP	40
9	2520-361	1/2 - 13 FLANGE WHIZ LOCK HEX NUT, GR 5, ZP	16
10	2520-364	1/2 -13 JAM LOCK HEX NUT	8
11	2520-459	5/8 – 11 LOCK HEX NUT, GR B, ZP	40
12	2520-515	3/4 - 10 LOCK HEX NUT, GR A, ZP	8
13	2526-449	5/8 FLAT WASHER, 1/4 THICK, ZP	16
14	2550-709	1/2 WIRE 2-1/2 OD X 1-1/2 ID X 7-1/4 COMPRESSION SPRING	8
15	2570-126	3/4 X 10 EYEBOLT, ZP	8
16	2570-465	7 GAUGE HAIRPIN COTTER ZP	16
17	2975-302	2975 SPRING BUSHING "PAINTED"	8
18	5000-202	MOUNT BRACKET W.A., SINGLE	4
	2528-369	1.380 OD X 1.00 ID X 1.25 L BEARING SLEEVE	
19	5000-211A	ROLLER W.A., LH, 76"	2
20	5000-212A	ROLLER W.A., RH, 76"	2
21	5000-254	ROLLER MOUNT 3 ROW	4
22	5000-256	OVER BEARING ARM 19" LH	6
23	5000-259	OVER BEARING ARM 19" RH	2
24	5000-263	MOUNT BRACKET W.A.	4
	2528-369	1.380 OD X 1.00 ID X 1.25 L BEARING SLEEVE	
25	5000-309	SUPPORT STRAP	16
26	5000-318	PIVOT BUSHING	8
27	5000-319	MOUNT STRAP 3"	16
28	5000-322	SHIM WASHER ZP	8
29	5000-323	LOCK UP PIN ZP	8
30	5000-355	1-1/4 DISC HARROW BEARING, W209PPB5, HD ASSEMBLY	8
	2550-059	DEVASTATOR BEARING ONLY (NO CAST HOUSING)	
31	5000-378	SPACER BUSHING	16
32	5000-402	WEDGE	2



# 5000-034 12 ROW FOLDING PART IDENTIFICATION

## CENTER 6 ROWS

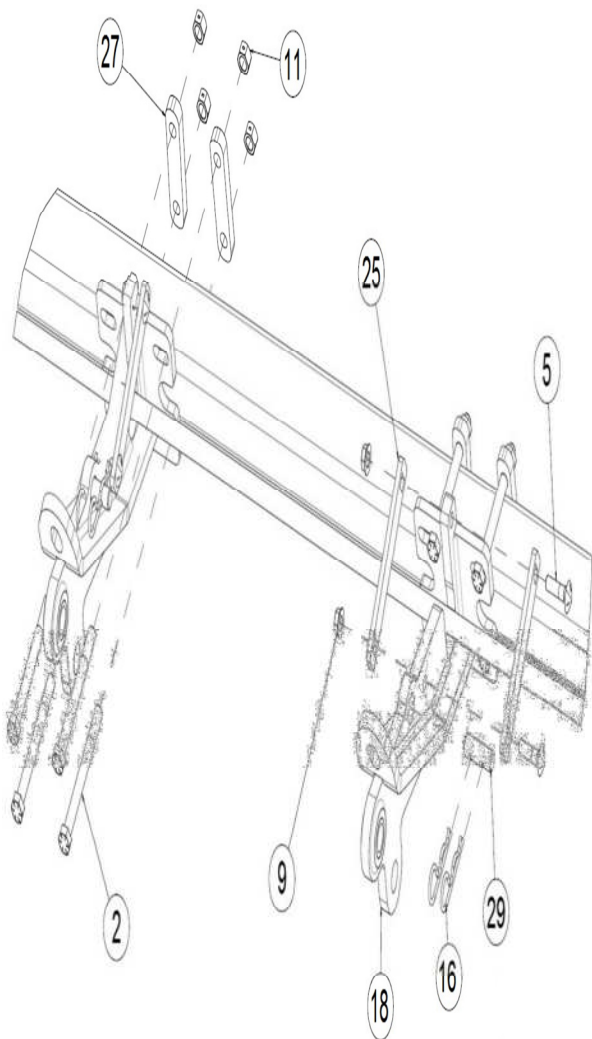

## OUTSIDE 3 ROWS ON EACH END

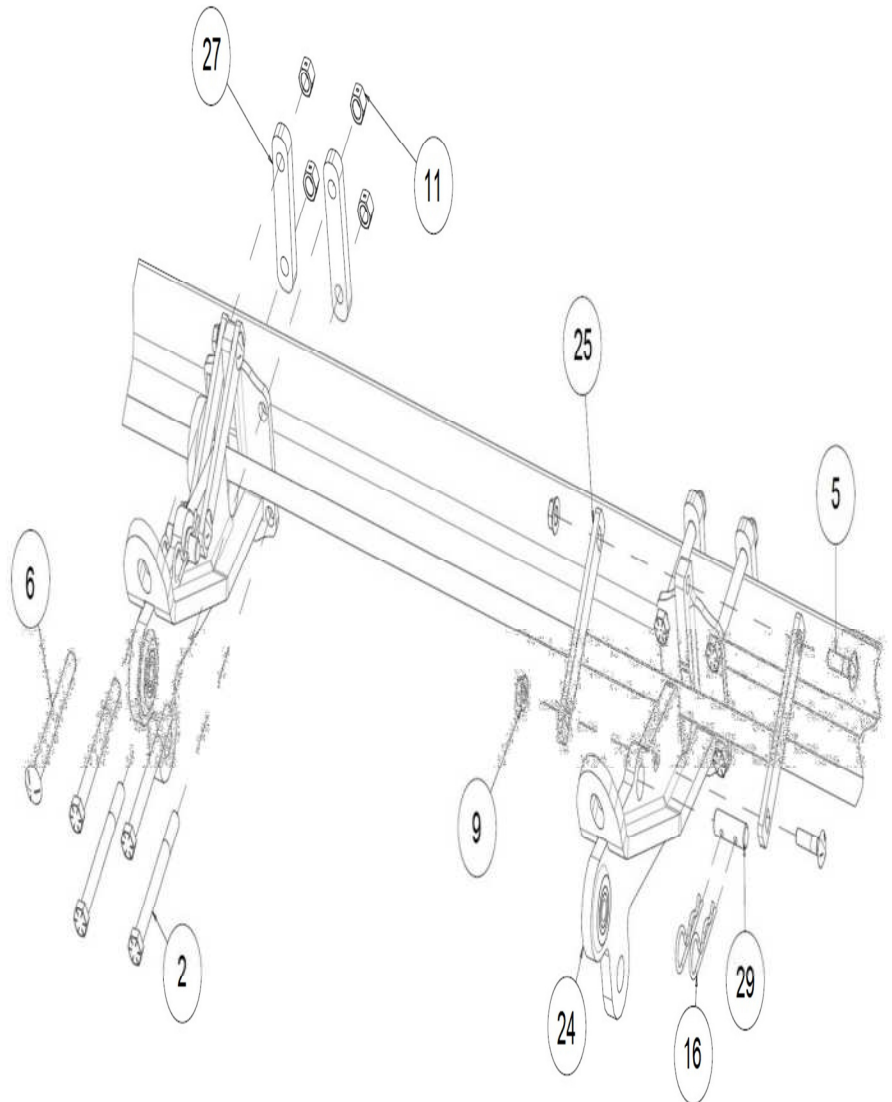

ITEM	PART #	DESCRIPTION	QUANTITY
2	2502-352	5/8 – 11 x 6 HHCS GR 8	32
5	2505-345	1/2 – 13 X 2 CARRIAGE BOLT GR 5	16
6	2505-414	5/8 – 11 X 6 CARRIAGE BOLT GR 5 (USED ON ROWS 10/11 & 11/12)	2
9	2520-361	1/2 - 13 FLANGE WHIZLOCK NUT GR 5	16
11	2520-459	5/8 – 11 LOCK HEX NUT GR B	40
16	2570-465	7 GAUGE HAIRPIN COTTER	16
18	5000-202	MOUNT BRACKET W.A., SINGLE	4
	2528-369	1.380 OD X 1.00 ID X 1.25 L BEARING SLEEVE	8
24	5000-263	MOUNT BRACKET W.A.	4
25	5000-309	SUPPORT STRAP	16
27	5000-319	MOUNT STRAP 3"	16
29	5000-323	LOCK UP PIN	8

# 5000-034 12 ROW FOLDING PART IDENTIFICATION

The model shown is the Part ID for rows 4 - 6 & 7 - 9.  
Rows 1 - 3 & 10 - 12 will have 2 of item 22 & 0 of item 23.

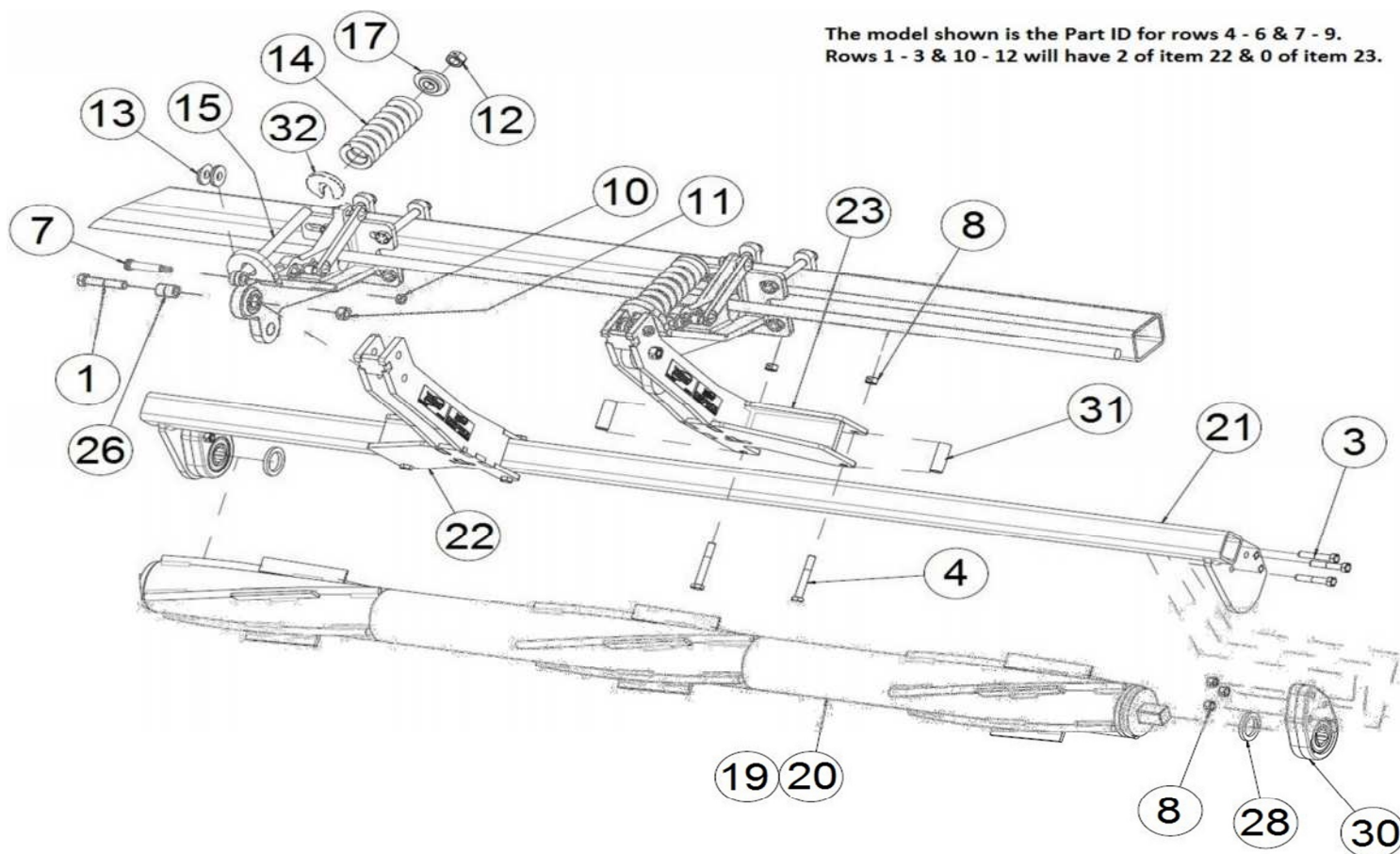

ITEM	PART #	DESCRIPTION	QUANTITY
1	2502-325	5/8 – 11 x 3 HHCS GR 5	8
3	2502-353	1/2 – 13 x 2 1/2 HHCS GR 8	24
4	2502-365	1/2 – 13 x 3 3/4 HHCS GR 5	16
7	2510-121	5/8" DIAMETER SHOULDER BOLT, 2 1/4 L SHOULDER, 1/2 - 13	8
8	2520-357	1/2 – 13 LOCK HEX NUT	40
10	2520-364	1/2 – 13 HEX LOCK JAM NUT	8
11	2520-459	5/8 – 11 LOCK HEX NUT GR B	40
12	2520-515	3/4 – 10 LOCK HEX NUT	8
13	2526-449	5/8 FLAT WASHER	16
14	2550-709	1/2 WIRE 2 1/2 OD X 1 1/2 ID X 7 1/4 COMPRESSION SPRING	8
15	2570-126	3/4 X 10 EYEBOLT, ZP	8
17	2975-302	2975 SPRING BUSHING	8
19	5000-211A	ROLLER W.A. LH, 76"	2
20	5000-212A	ROLLER W.A. RH, 76"	2
21	5000-254	ROLLER MOUNT 3 ROW	4
22	5000-256	OVER BEARING ARM 19" LH	6
23	5000-259	OVER BEARING ARM 19" RH	2
26	5000-318	PIVOT BUSHING	8
28	5000-322	SHIM WASHER	8
30	5000-355	1 1/4 DISC HARROW BEARING, W209PPB5, HD ASSY	8
	2550-059	DEVASTATOR BEARING ONLY	8
31	5000-378	SPACER BUSHING	16
32	5000-402	WEDGE (USED ON MOUNT BRACKETS FOR ROWS 1 – 3)	2











# TROUBLESHOOTING

ISSUE	CAUSE	CORRECTIVE ACTION
Residue Plugging	<ol style="list-style-type: none"> <li>1. Incorrect Head Angle</li> <li>2. Roller Mount Tube incorrectly installed</li> <li>3. Pivot arm orientation incorrect</li> <li>4. Bearing installed incorrectly</li> <li>5. Intermeshing snapping rolls</li> <li>6. Too much Spring Tension</li> </ol>	<ol style="list-style-type: none"> <li>1. Adjust head angle to 23 – 25 degrees (<b>see page 37</b>)</li> <li>2. Make sure the Bearing Support Tab is on the backside of the Roller Arm Mount Tube</li> <li>3. Reposition the pivot arm so that it offsets under the snout &amp; not under the row</li> <li>4. Make sure the side of the bearing that protrudes outside of the cast housing is facing toward the roller (each roller should spin freely by hand)</li> <li>5. Order the 5000-080 Set Back Kit (order 2 per roller)</li> <li>6. Back the nut off of the push rod until the nut is flush</li> </ol>
Stalk aren't "devastated"	<ol style="list-style-type: none"> <li>1. Insufficient spring down pressure</li> <li>2. Operating corn head too high</li> </ol>	<ol style="list-style-type: none"> <li>1. Tighten push rod nut on spring bushing more</li> <li>2. Lower corn head until the rollers engage</li> </ol>
Corn Head won't fit on head cart	<ol style="list-style-type: none"> <li>1. Devastators bottom out</li> <li>2. Roller won't clear cart tire</li> <li>3. Storage stands don't rest in the saddles on the cart</li> </ol>	<ol style="list-style-type: none"> <li>1. Adjust top rail &amp; saddles higher on cart</li> <li>2. Order 5000-082 Lift Kit (raises roller 2")</li> <li>3. Order 5000-081 Head Extensions (JD 600 &amp; 700 series only)</li> </ol>

## NOTES



A Tradition of Solutions since 1930

Yetter Farm Equipment Co

PO BOX 358 109 S. McDonough

Colchester, IL 62326-0358

Phone: 309-776-4111

Toll Free: 800-447-5777

Email: [info@yetterco.com](mailto:info@yetterco.com)

For updated models and manuals visit the Yetter website:

[www.yetterco.com](http://www.yetterco.com)

© Yetter Farm Equipment Co. All Rights Reserved

2565-785\_Rev\_D – 12/2018