



**2984-050-R
CAB CONTROL™
STRIP FRESHENER™
YETTER COMPRESSOR**

OPERATOR MANUAL
PARTS IDENTIFICATION
2565-968 • 11/2019



YETTER MANUFACTURING CO.
FOUNDED 1930

Colchester, IL 62326-0358
Toll free: 800/447-5777
309/776-3222 (Fax)
Website: www.yetterco.com
E-mail: info@yetterco.com

GERMINATE UNIFORMITY™

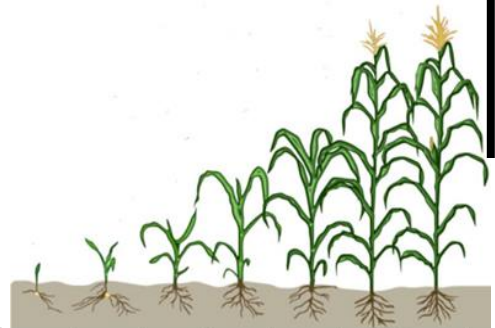

FOREWORD

You've just joined an exclusive but rapidly growing club.

For our part, we want to welcome you to the group and thank you for buying a Yetter product.

We hope your new Yetter products will help you achieve both goals-increase your productivity and increase your efficiency so that you may generate more profit.

This operator's manual has been designed into four major sections: Foreword, Safety Precautions, Installation Instructions and Parts Breakdown.



This **SAFETY ALERT SYMBOL** indicates important safety messages in the manual. When you see this symbol, be alert to the possibility of **PERSONAL INJURY** and carefully read the message that follows.

The word **NOTE** is used to convey information that is out of context with the manual text. It contains special information such as specifications, techniques and reference information of a supplementary nature.

The word **IMPORTANT** is used in the text when immediate damage will occur to the machine due to improper technique or operation. Important will

apply to the same information as specified by note only of an immediate and urgent nature.

It is the responsibility of the user to read the operator's manual and comply with the safe and correct operating procedure and to lubricate and maintain the product according to the maintenance schedule in the operator's manual.

The user is responsible for inspecting his machine and for having parts repaired or replaced when continued use of the product would cause damage or excessive wear to the other parts.

It is the user's responsibility to deliver his machine to the Yetter dealer who sold him the product for service or replacement of defective parts, which are covered by the warranty policy.

If you are unable to understand or follow the instructions provided in this publication, consult your local Yetter dealer or contact:

YETTER MANUFACTURING CO.

309/776-4111

800/447-5777

309/776-3222 (FAX)

Website: www.yetterco.com

E-mail: info@yetterco.com

WARRANTY

Yetter Manufacturing warrants all products manufactured and sold by it against defects in material. This warranty being expressly limited to replacement at the factory of such parts or products as shall appear to be defective after inspection. This warranty does not obligate the Company to bear cost of labor in replacement of parts. It is the policy of the Company to make improvements without incurring obligations to add them to any unit already sold. No warranty is made or authorized to be made, other than herein set forth. This warranty is in effect for one year after purchase.

DEALER _____

Yetter Manufacturing warrants its own products only and cannot be responsible for damages to equipment on which mounted.

SAFETY PRECAUTIONS

A brief description of signal words that may be used in this manual:

CAUTION: Used as a general reminder of good safety practices or to direct attention to unsafe practices.

WARNING: Denotes a specific potential hazard.

DANGER: Denotes the most serious specific potential hazard.



CAUTION

Consult your implement and tractor operator's manual for correct and safe operating practices. Be aware of towed implement width and allow safe clearance.



CAUTION: SAFETY SIGNS

Safety decals are placed on the implement to alert the operator and others to the risk of personal injury or unsafe operation during normal operations and servicing.

1. The safety decals must be kept clean and in good condition to ensure that they are legible.
2. Safety decals must be replaced if they are missing or illegible.
3. When components are replaced during repair or servicing, check that the new components include the necessary safety signs.
4. Replacement safety decals may be obtained from your local dealer.



WARNING

Read these instructions carefully to acquaint yourself with the Equipment. Working with unfamiliar equipment can lead to accidents.

Never park the equipment on a steep incline or leave the equipment running unattended.

Never clean, lubricate or adjust a machine that is in motion.

Always check that straps are secure.

Make sure latches are in pinned position when moving equipment.

Do not allow children to operate this equipment.

Do not allow riders on the equipment, trailer and/or pick-up.

Use speed and caution dictated by the terrain being traversed. Do not operate on any slope steep enough to cause tipping or loss of control.

Read and understand the operator's manual and require all other persons who will operate the equipment to do the same.

If operating on public roadways, where legal, be certain all lighting is operating properly and observe all traffic laws.

Beware of increased stopping distances and control effort when operating with implements attached.

Be familiar with all controls and be prepared to stop equipment quickly in an emergency.

FAILURE TO HEED MAY RESULT IN PERSONAL INJURY OR DEATH.

TABLE OF CONTENTS

FOREWORD/WARRANTY.....	2
SAFETY PRECAUTIONS.....	3
2984 STRIP FRESHENER CC ADVANTAGES & DIMENSIONS.....	4
FEATURES / BOLT TORQUE.....	5
ASSEMBLY INSTRUCTIONS.....	6 – 15
OPERATION PRECAUTIONS.....	16 – 17
OPERATION.....	17 – 18
MAINTENANCE.....	19 – 20
PARTS IDENTIFICATION	
2984-050-R STRIP FRESHENER CC ASSEMBLY.....	21 – 22
2984-132 PARALLEL LINKAGE ASSEMBLY.....	23
NARROW ROW CLEANER ASSEMBLY.....	24
WIDE ROW CLEANER ASSEMBLY.....	25
GAUGE WHEEL ASSEMBLY.....	26
ROLLING BASKET ASSEMBLY.....	27
ROW CLEANER MOUNT & DEPTH STOP ASSEMBLY.....	28
SHARKTOOTH WHEEL & COULTER BLADE ASSEMBLY.....	29
COULTER HUB & SCREW ADJUST ASSEMBLY.....	30
FERTILIZER ADD ON OPTIONS.....	31 – 32
TROUBLESHOOTING.....	33

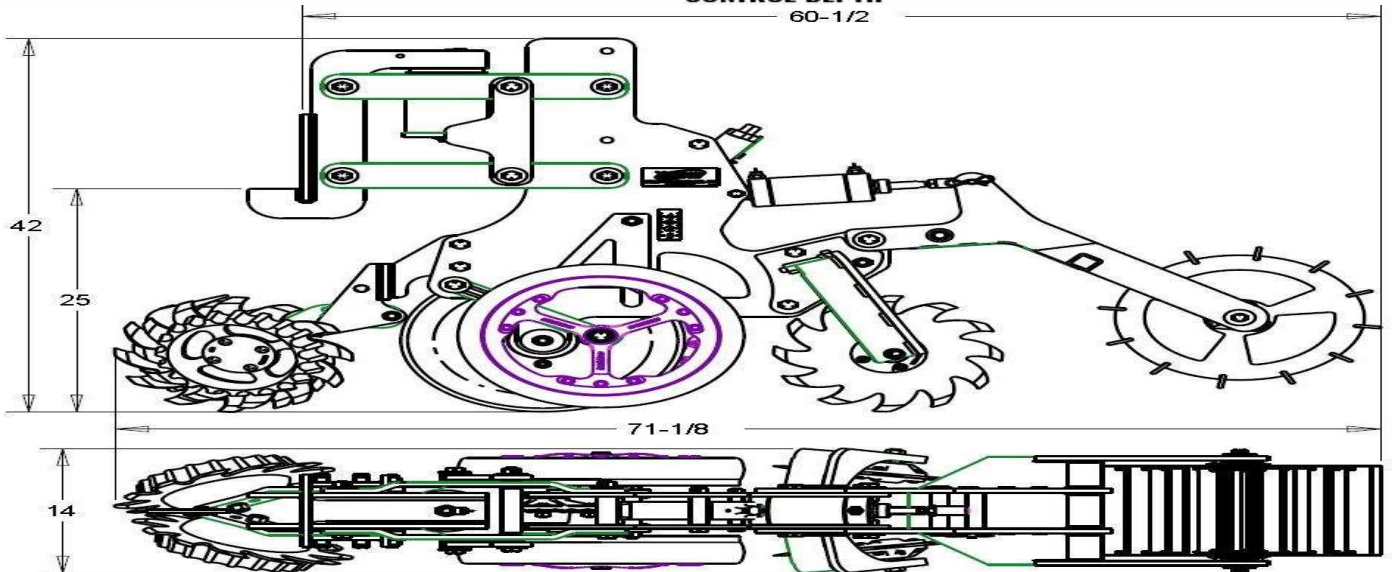
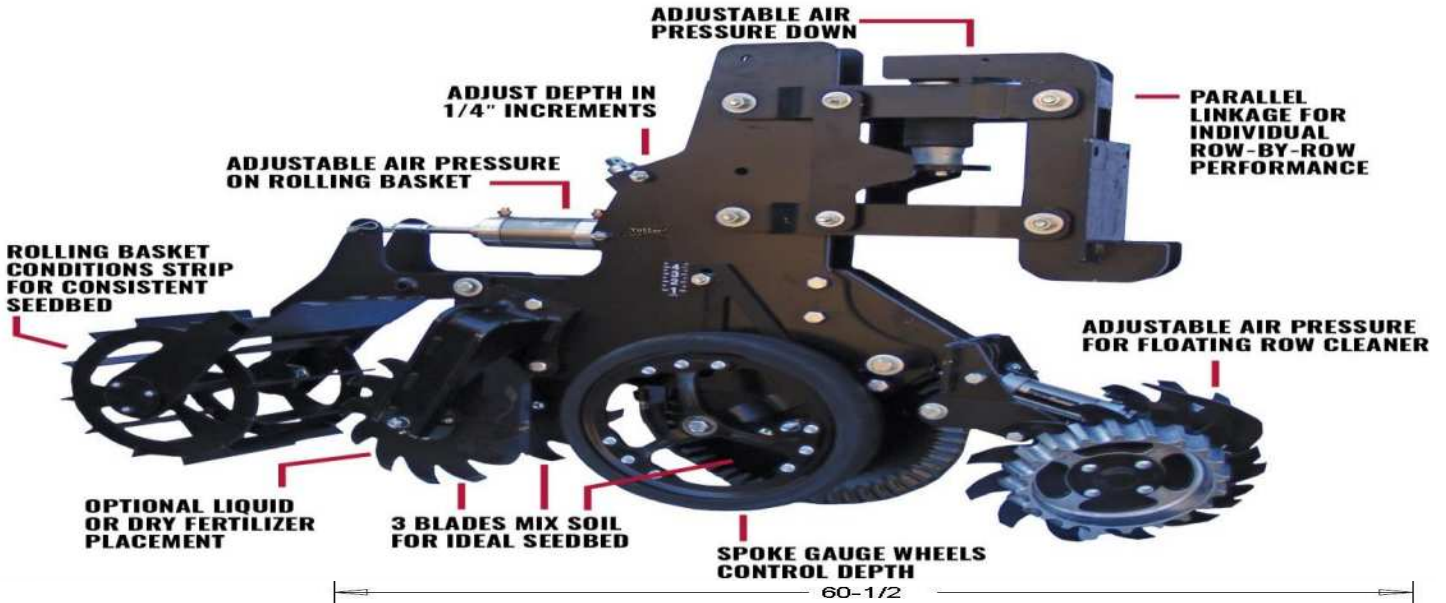

2984-050-R Yetter Strip Freshener

Features:

- Parallel Linkage & Pneumatic Row Unit Down Force for consistency for all field contours, soil types, & field conditions.
- Designed for use with pneumatic row cleaner to enhance strip cleanliness
- Operating speeds between 6-10mph & depth adjustment between 1"-4"
- Two Shark Tooth wheels run at an angle to churn dirt for optimal seed bed preparation
- Optional liquid or dry fertilizer kits are available for additional value to this field pass
- Heavy Duty, Pneumatic Rolling Basket conditions the strip

BOLT TORQUE

Mounting bolts and hardware

All hardware is Grade 5 unless otherwise noted. Grade 5 cap screws are marked with 3 radial lines on the head. If hardware must be replaced, be sure to replace it with hardware of equal size, strength & thread type. Refer to the torque values chart when tightening hardware.







Important: Over-tightening hardware can cause just as much damage as under-tightening. Tightening hardware beyond the recommended range can reduce its shock load capacity.

The chart below is a guide for proper torque. Use it unless a specified torque is called out elsewhere in the manual. Torque is the force applied to the end of the handle or cheater bar, times the length of the handle or bar.

Use a torque wrench wherever possible.

The following table shows torque in ft.-lbs. for coarse thread hardware.

Bolt Diameter and Threads per Inch	 Grade 2	 Grade 5	 A-325	 Grade 8
1/4	6	10	14	14
5/16	12	20	30	30
3/8 – 16	25	35	50	50
7/16 – 14	35	55	80	80
1/2 – 13	55	85	125	125
9/16 – 12	75	125	175	175
5/8 – 11	105	170	235	235
3/4-10	185	305	425	425
7/8 – 9	170	445	690	690
1-8	260	670	1030	1030
1 1/8 – 7	365	900	1460	1460
1 1/4 - 7	515	1275	2060	2060
1 3/8 –6	675	1675	2700	2700
1 1/2 - 6	900	2150	3500	3500
1 3/4 – 5	1410	3500	5600	5600

CHECK HARDWARE DAILY FOR DAMAGE, WEAR, & LOOSENESS. TIGHTEN AS NEEDED

Assembly Instructions

Prepping the Toolbar

Mark the center of the toolbar. Once the center is marked, measure off of the mark half the distance of what the row spacing of each unit will be. For example, if you are setting up the toolbar for 30" row spacing, measure off of your center mark 15" on each side and make a mark. A 30" layout is pictured below for reference. If you are setting the toolbar up on 20" row spacing, measure 10" on each side of the center mark and make a mark. Mark the center of the mounting plate on each strip freshener.

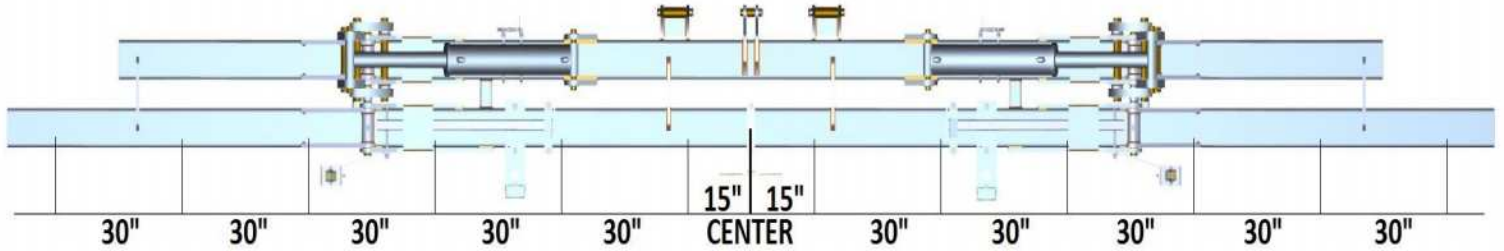

Installing the units

Align the marks on the toolbars where each strip freshener is to be installed with the marks on the mounting plate on the strip freshener & use the hardware to mount each unit. If clearance issues with weldments or hinge points on the toolbar arise, alternate parts may be required. Fold the toolbar when all units installed to check for any clearance issues.

2984-046 - 4 X 6 ADAPTER KIT

2984-066 - 6 X 6 ADAPTER KIT

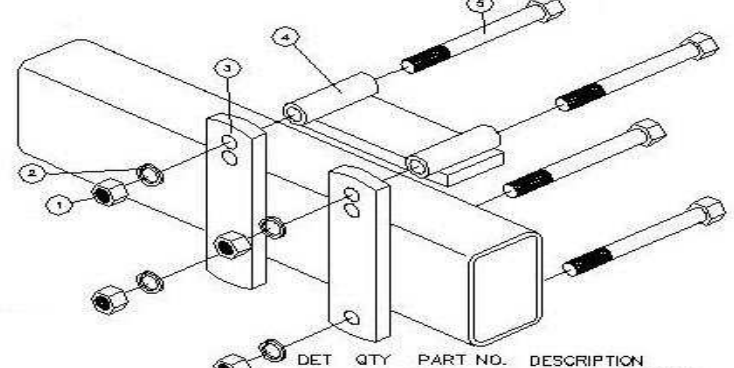
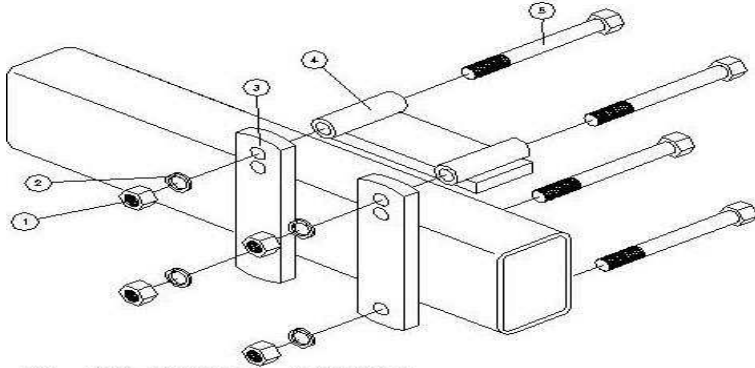

DET	QTY	PART NO.	DESCRIPTION
1	4	2520-504	3/4-10 HEX NUT
2	4	2525-501	3/4 LOCKWASHER
3	2	2986-306	STRAP
4	1	2986-224	ADAPTER
5	4	2502-509	3/4-10 X 7 HHCS GR5

DET	QTY	PART NO.	DESCRIPTION
1	4	2520-504	3/4-10 HEX NUT
2	4	2525-501	3/4 LOCKWASHER
3	2	2986-306	STRAP
4	1	2986-224	ADAPTER
5	4	2502-514	3/4-10 X 9 HHCS GR5

2984-057 5" X 7" U-BOLT KIT

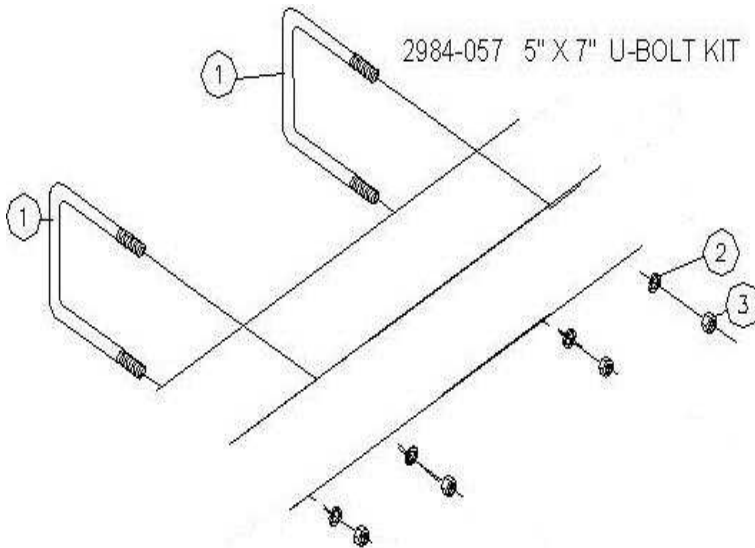

2984-077 7" X 7" U-BOLT KIT

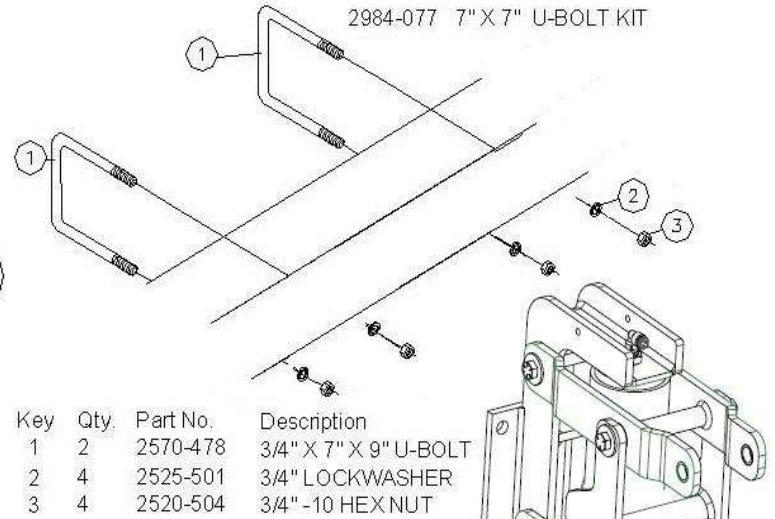

Key	Qty	Part No.	Description
1	2	2570-478	3/4" X 7" X 9" U-BOLT
2	4	2525-501	3/4" LOCKWASHER
3	4	2520-504	3/4" -10 HEX NUT

Key	Qty	Part No.	Description
1	2	2570-477	3/4" X 7" X 7" U-BOLT
2	4	2525-501	3/4" LOCKWASHER
3	4	2520-504	3/4" -10 HEX NUT

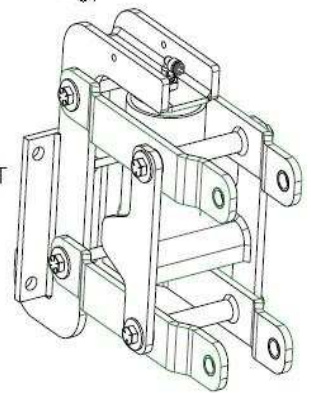

Assembly Instructions

Row Cleaner Assembly

Assemble the wide or narrow pivot arm, depending on application, to the mount on the strip freshener CC unit. Narrow arms will go on the inside of the row cleaner mount plates & wide arms will go on the outside of the row cleaner mount plates. Place a pivot bushing in the rear hole on each side of the pivot arms, align the hole on each arm with the rear hole on each side of the row unit row cleaner mount bracket, slide a 5/8" X 2" bolt through, & fasten with a 5/8" lock nut. Install the down stop & up stop components next. Install a 1/2" X 1 3/4" bolt through the remaining 2 holes on each side of the row cleaner mount plate, slide a 9/16" spacer over each bolt, & fasten in place with a 1/2" lock nut. Assemble the air cylinder to the row cleaner; place the rod end of the cylinder over the hole on the pivot arm handle & install the shorter pin & 1/8" cotter pin. Install the anchor end of the cylinder between the mount tabs on the row cleaner faceplate & install the longer pin & 1/8" cotter pin. Place the half-moon shield over the axle D-bolt on the row cleaner wheel assembly, slide the D-bolt in the D-hole on the pivot arms, & fasten the wheel assembly to the pivot arm using a 5/8" lock washer & 5/8" lock nut. LH wheels go on the LH side of the pivot arm & RH wheels go on the right. On the LH side of the toolbar, the LH wheels should be in the front hole & RH wheels in the rear hole. On the RH side of the toolbar, the RH wheels should be in the front hole & the LH wheels in the rear hole. LH & RH side is determined by sitting in the tractor cab facing forward.

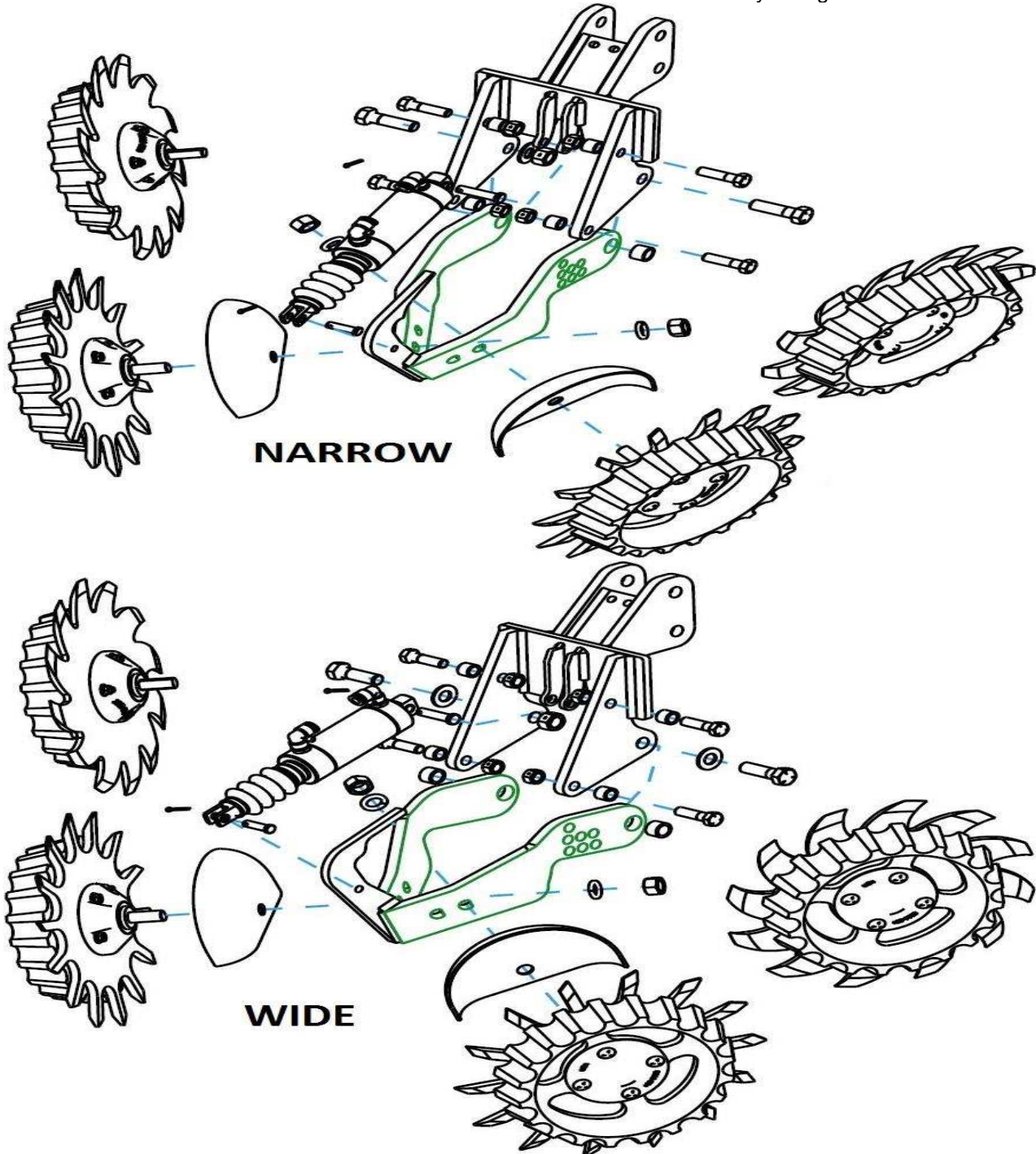

Assembly Instructions

Hydraulic Compressor Assembly (if ordered)

Plumbing

- A) Attach the hydraulic pressure gauge to the port on the hydraulic block labeled GP.
- B) Remove the cap from the - 6 port (also labeled P on the Hydraulic Control Block) & install the 2515-431 - 6 ORB (O-Ring Boss) to - 6 JIC straight adaptor fitting so that the O-Ring end goes into the hydraulic block & the JIC end faces away from the block. Install 1) 2515-831 3/8 - 6 10ft hydraulic hose to that fitting.
- C) Remove the cap from the - 8 port (also labeled T on the Hydraulic Control Block) & install the 2515-833 - 8 ORB to - 8 JIC straight adaptor fitting so that the O-Ring end goes into the hydraulic block & the JIC end faces away from the block. Install the 2515-832 1/2 - 8 10ft hydraulic hose to that fitting.

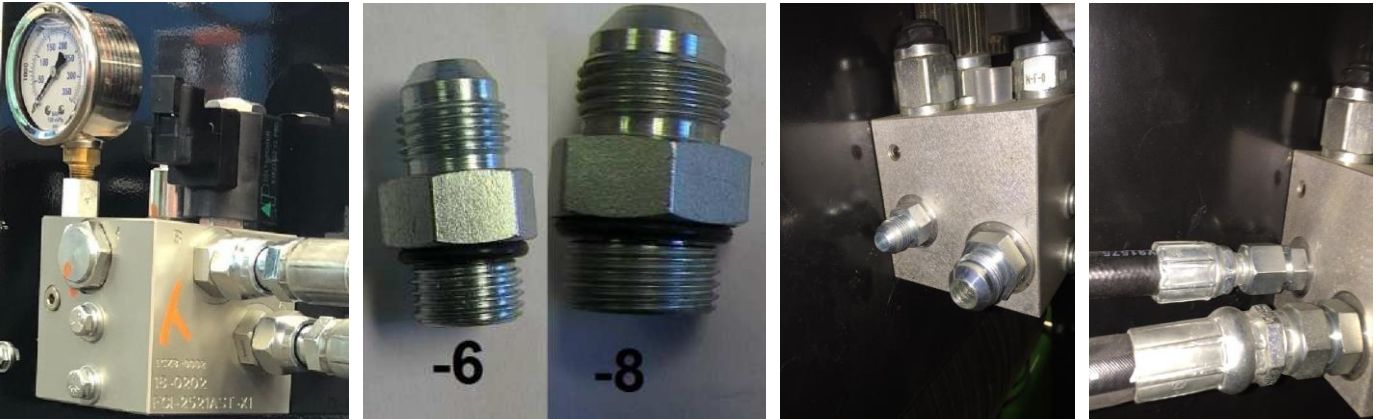

- C) Remove the cap plug from the - 4 port on the motor using a 3/16 hex key wrench (this is the Case Drain) & install the 2515-848 -4 ORB to - 6 JIC 90 degree adaptor fitting so that the O-Ring end goes into the hydraulic motor & the JIC end faces downward. Install 1) 2515-831 3/8 - 6 10ft hydraulic hose to that fitting.



Attach 1 pioneer coupler to the 1/2" hydraulic hose for the compressors return using -8JIC - 8ORB adaptor. Attach 1 pioneer coupler to the 3/8" hydraulic hose for the compressor pressure using -6JIC - 8ORB adaptor. Connect the hydraulic hose attached to case drain on the motor to the case drain connector on the tractor. Case drain coupler not provided. The Yetter hyd. compressor is equipped with a case drain port on the motor. Case Drain is a pressure free circuit that provides a flow path to the reservoir for hydraulic fluid used to cool & lubricate the motor. Make sure to connect case drain to reservoir where the hydraulic flow to the compressor is received. If tractor isn't equipped with case drain, a kit may be purchased from the tractor OEM dealer.

PIONEER COUPLER



CASE DRAIN FLAT FACE COUPLERS



CONNECTED AT TRACTOR DRAIN



Assembly Instructions

Electric Compressor Assembly (if ordered)

Mounting – Each strip till machine will have its own unique mounting location. Select an area to mount the compressor that is centrally located near hitch of tractor. **YOU SHOULD EXERCISE YOUR OWN BEST JUDGEMENT TO FIT YOUR SITUATION.** Use mounts supplied or depending on application different mounts may need to be built or Yetter mounts may need modified. Be sure to check clearance in all locations, especially noting tractor tires, folding/unfolding toolbar for transport mode, marker arms, & fertilizer tanks. The 2940-086 universal mount kit will be most commonly used mount for this application.

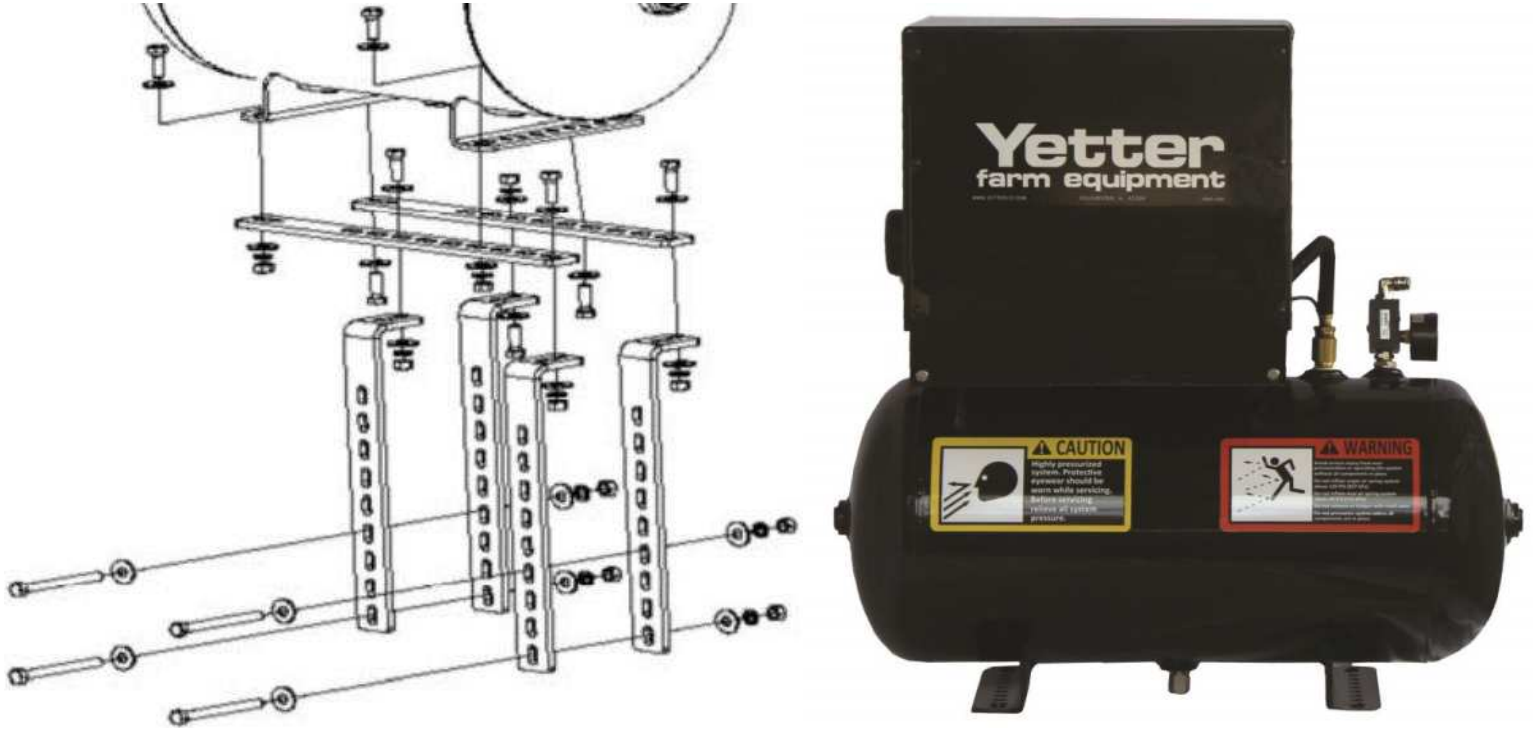

Power Cable Installation - : Install the 2940-150 main power cable with 80A breaker on the operating tractor's battery. Red cable installs on the positive (+) battery terminal post and the black cable installs on the negative (-) battery terminal post. From the open 2 pole Anderson connector of the 2940-150, safely route & install the appropriate length of main power extension cables, 2940-151 is a 10ft main power extension & 2940-163 is a 20ft main power extension, into the Anderson connector that comes out of the bottom of the compressor housing. If operating tractor is articulating or if compressor is further back on the planter than the hitch, more extension cables may be needed. **Cable length from the battery to the compressor should not exceed 50 feet. Longer than 50 feet distances cause the 80A breaker to become weak and trip often. If distance is greater than 50 feet, heavier cable needs made using 00 gauge wire.**



Assembly Instructions

Mount the Control Box

Attach the 2984-512 Ram ball base to the tractor's monitor mounting device. Some tractors have round tube & some have slotted flat steel. Pick a location near the right rear corner post so that adjustments can be made easily while viewing the strip freshener units' performance. Attach the double socket arm to the tractor mounted ball and the control box mounted ball and tighten the T-knob to fix the control box into place.

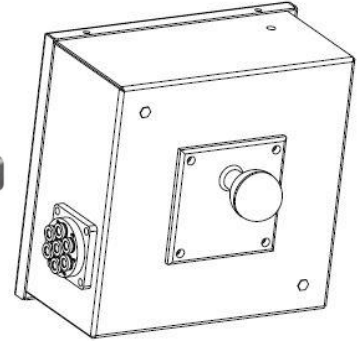

Plumbing the Control Box

Route the tubing harness (10ft of tubing side) into the back of the tractor cab & plug the tubing into the side of the control box connector.

1 – compressor; 2 – row cleaner down, 3 – row cleaner up, 4 – row unit down force, 5 – rolling basket down, 6 – rolling basket up
The center port is not used. The 5ft of tubing on the other side of the hitch bulkhead connector will plumb into each corresponding circuit on the toolbar.

1 – compressor; 2 – row cleaner down, 3 – row cleaner up, 4 – row unit down force, 5 – rolling basket down, 6 – rolling basket up

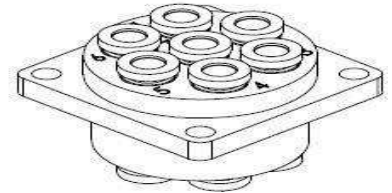
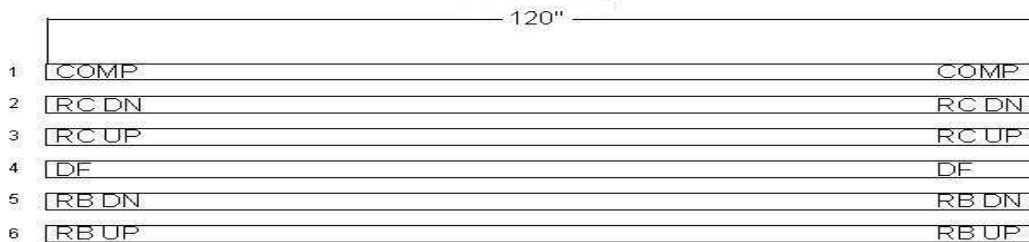
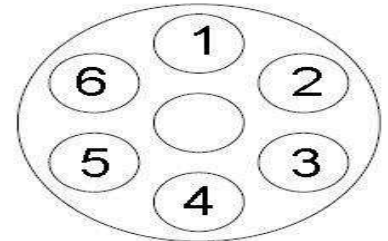
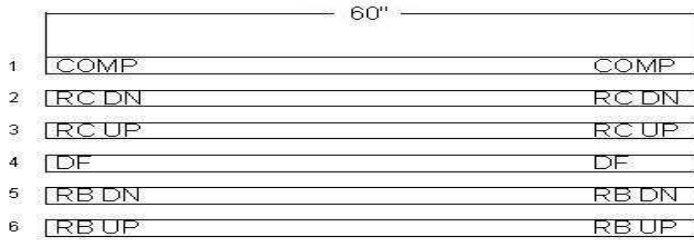

Plumbing the Compressor

Insert the 1200-353 3/8 Stem to 1/4PC reducer into the outlet 3/8" outlet elbow on the compressor. Install the 1/4" airline from the tubing harness labeled COMP into the 1/4"PC.



Assembly Instructions

Switched Power – Electric or Hydraulic Compressors

Attach the male 2 pin connector of the 2940-153 to the female 2 pin connector on the 2984-156 Cab Controller that is closest to the front side. Install the connector not provided for your tractor at the bare end of the 2940-153 and connect to tractors switched power source. Connect the black wire on the Yetter harness to the black wire of the switched power harness. Connect the red wire on the Yetter harness to the orange wire on the switched power harness. Connecting the red wire on the Yetter harness to the red wire on the switched power harness will provide constant power to the switch on the Yetter control box and may lead to draining the tractor's battery.

At the compressor, install the compressor control harness; 1) male 2 pin connector plugs into extension harness from tractor cab, 1) male 2 pin connector plugs into the compressors solenoid, & 1) 2 pin female connector plugs into pressure switch.

Install 1) 2940-156 15' extension from the connector near the back side of the cab controller to the hitch of the tractor. Install as many of the 2940-154 30' Extensions as necessary to connect the Y harness at the compressor to the 2 pin connector at the hitch of the tractor.



Switched Power Source
Connector part #'s:

JD PART #: RE67013

CNH PART #: 187103A1

CAT P/N: AG233356

----->

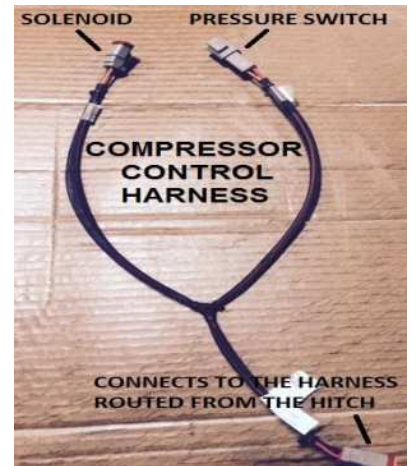
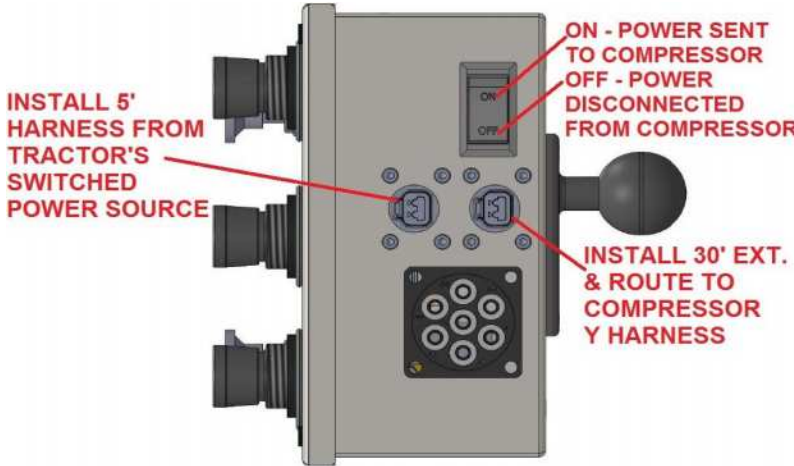

HYDRAULIC COMPRESSOR

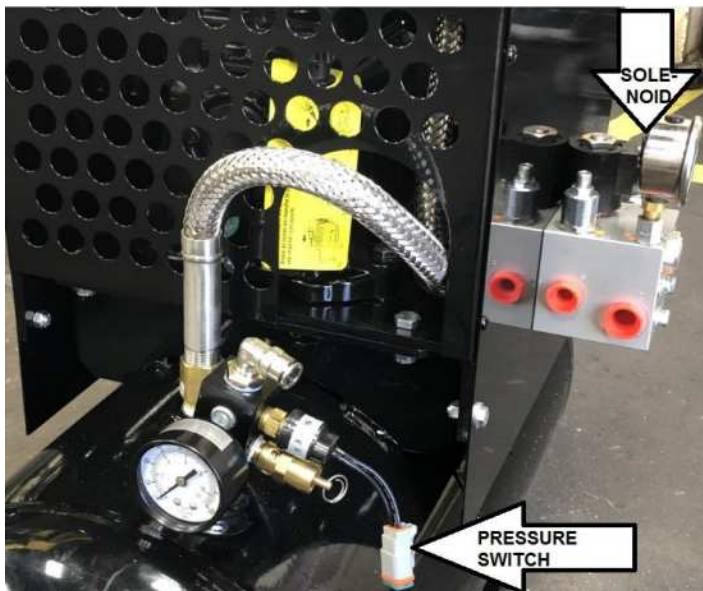

ELECTRIC COMPRESSOR

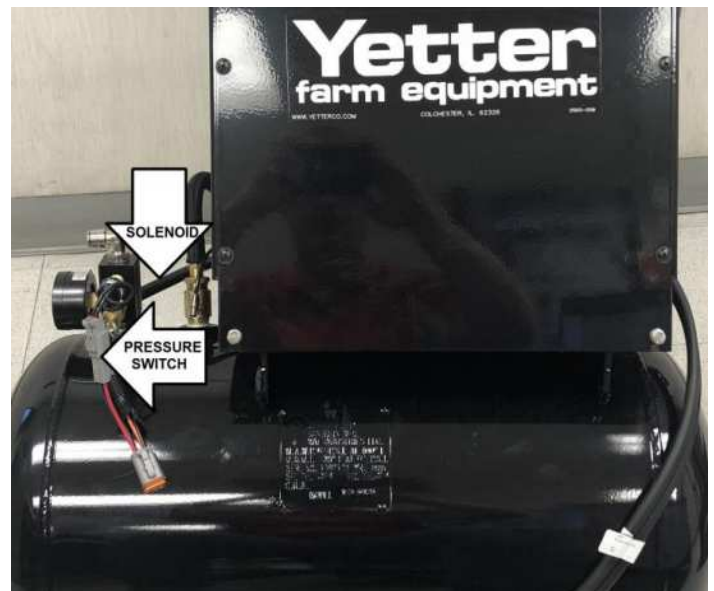

Assembly Instructions

Plumbing each Strip Freshener Circuit

General Plumbing Instructions Smaller, rigid toolbars will have 1 trunk airline from the 1st row to the last row for each circuit. Folding toolbars will have 3 trunk airline groups for each circuit; left wing, center frame, & right wing. See diagrams for rigid (8 row shown) & folding (16 row shown) as a template for your application. Make sure when cutting in tees for each row for a particular circuit that you make sure the airline you are cutting to apply the tee to is the correct circuit. Keep airline away from wear points & pinch points. Each end of the airline should be cut flush. Make sure to leave plenty of slack at the hinges for folding/unfolding.

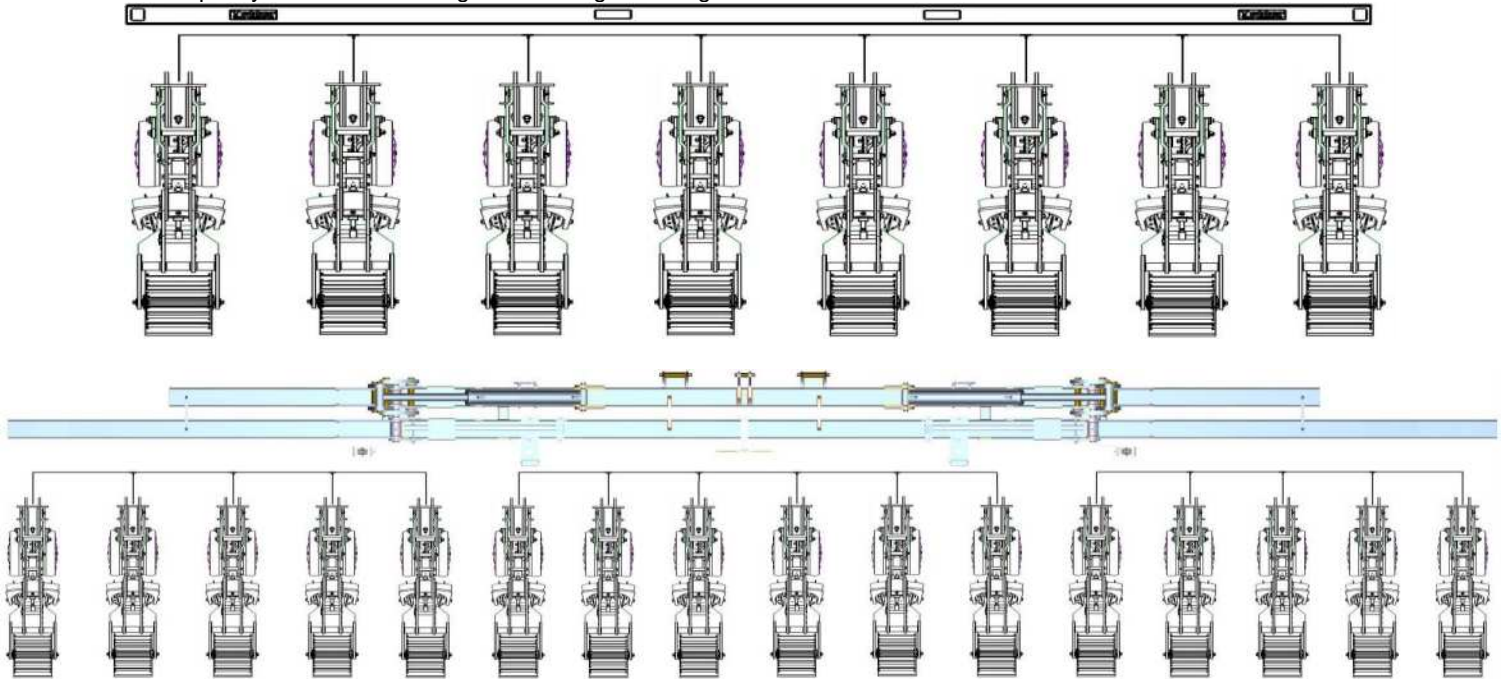

Row Cleaner Down – Use 1/4" black airline & 1/4" tees to plumb this circuit.

On rigid toolbars, start at row 1 & route the airline to the last row & install into the fitting on the down pressure side of the cylinder. Trace this airline back to row 1 installing 1/4" tees at each row. At row 1, cut the airline to length & install into the fitting on the down pressure side of the cylinder. At the tee installed at each row, install airline from the tee to the fitting on the down pressure side of the air cylinder. Install a 1/4" tee in this trunk line near the center of the toolbar & install the 1/4" airline labeled RC DN on the tubing harness from the cab controller.

On folding toolbars, start at row 1 & route airline to the last row on the left wing & install into the fitting on the down pressure side of the cylinder. Trace this airline back to row 1 installing a tee at each row. At row 1, cut the airline to length & install into the fitting on the down pressure side of the cylinder. At the tee installed at each row, install airline from the tee to the fitting on the down pressure side of the air cylinder. Repeat process for the center frame & the right wing rows. Install airline & tees to connect the left wing & right wing to the center frame trunk line. Install a 1/4" tee in the center frame trunk line near the center of the toolbar & install the 1/4" airline labeled RC DN on the tubing harness from the cab controller.

Row Cleaner Up – Use 1/4" black airline & 1/4" tees to plumb this circuit.

On rigid toolbars, start at row 1 & route the airline to the last row & install into the fitting on the up pressure side of the cylinder. Trace this airline back to row 1 installing 1/4" tees at each row. At row 1, cut the airline to length & install into the fitting on the up pressure side of the cylinder. At the tee installed at each row, install airline from the tee to the fitting on the up pressure side of the air cylinder. Install a 1/4" tee in this trunk line near the center of the toolbar & install the 1/4" airline labeled RC UP on the tubing harness from the cab controller.

On folding toolbars, start at row 1 & route airline to the last row on the left wing & install into the fitting on the up pressure side of the cylinder. Trace this airline back to row 1 installing a tee at each row. At row 1, cut the airline to length & install into the fitting on the up pressure side of the cylinder. Repeat this process for the center frame & the right wing rows. Install airline & tees to connect the left wing & right wing to the center frame trunk line. Install a 1/4" tee in the center frame trunk line near the center of the toolbar & install the 1/4" airline labeled RC UP on the tubing harness from the cab controller.

1/4" TEE



Assembly Instructions

Row Unit Down Force – Use 3/8" black airline & 3/8" tees to plumb this circuit.

On rigid toolbars, start at row 1, route the airline to the last row & install into the elbow fitting on the down force air bag. Trace this airline back to row 1 installing 3/8" tees at each row. At row 1, cut the airline to length & install into the fitting on the down force air bag. At the tee installed at each row, install airline from the tee to the fitting on the down pressure air bag. Install a 3/8" X 3/8" X 1/4" tee reducer in this trunk line near the center of the toolbar & install the 1/4" airline labeled DF on the tubing harness from the cab controller to the 1/4" port of the tee reducer.

On folding toolbars, start at row 1, route airline to the last row on the left wing & install into the fitting on the down force air bag. Trace this airline back to row 1 installing a tee at each row. At row 1, cut the airline to length & install into the fitting on the down force air bag. At the tee installed at each row, install airline from the tee to the fitting on the down pressure air bag. Repeat this process for the center frame & right wing rows. Install airline & tees to connect the left wing & right wing to the center frame trunk line. Install a 3/8" X 3/8" X 1/4" tee reducer in the center frame trunk line near the center of the toolbar & install the 1/4" airline labeled DF on the tubing harness from the cab controller.

Rolling Basket Down – Use 3/8" black airline & 3/8" tees to plumb this circuit.

On rigid toolbars, start at row 1 & route the airline to the last row & install into the fitting on the down pressure side of the rolling basket air cylinder. Trace this airline back to row 1 installing 3/8" tees at each row. At row 1, cut the airline to length & install into the fitting on the down pressure side of the rolling basket air cylinder. At the tee installed at each row, install airline from the tee to the fitting on the down pressure side of the rolling basket air cylinder. Install a 3/8" X 3/8" X 1/4" tee reducer in this trunk line near the center of the toolbar & install the 1/4" airline labeled RB DN on the tubing harness from the cab controller.

On folding toolbars, start at row 1 & route airline to the last row on the left wing & install into the fitting on the down pressure side of the rolling basket air cylinder. Trace this airline back to row 1 installing a tee at each row. At row 1, cut the airline to length & install into the fitting on the down pressure side of the rolling basket air cylinder. At the tee installed at each row, install airline from the tee to the fitting on the down pressure side of the rolling basket air cylinder. Repeat this process for the center frame & the right wing rows. Install airline & tees to connect the left wing to the center frame trunk line & the right wing to the center frame trunk line. Install a 3/8" X 3/8" X 1/4" tee reducer in the center frame trunk line near the center of the toolbar & install the 1/4" airline labeled RB DN on the tubing harness from the cab controller.

Rolling Basket Up – Use 3/8" blue airline & 3/8" tees to plumb this circuit.

On rigid toolbars, start at row 1 & route the airline to the last row & install into the fitting on the up pressure side of the rolling basket air cylinder. Trace this airline back to row 1 installing 3/8" tees at each row. At row 1, cut the airline to length & install into the fitting on up pressure side of rolling basket air cylinder. At the tee installed at each row, install airline from the tee to the fitting on the up pressure side of the rolling basket air cylinder. Install a 3/8" X 3/8" X 1/4" tee reducer in this trunk line near the center of the toolbar & install the 1/4" airline labeled RB UP on the tubing harness from the cab controller.

On folding toolbars, start at row 1 & route airline to the last row on the left wing & install into the fitting on up pressure side of rolling basket air cylinder. Trace this airline back to row 1 installing a tee at each row. At row 1, cut the airline to length & install into the fitting on the up pressure side of the rolling basket air cylinder. At the tee installed at each row, install airline from the tee to the fitting on the down pressure side of the rolling basket air cylinder. Repeat this process for the center frame & the right wing rows. Install airline & tees to connect the left & right wing to the center frame trunk line. Install a 3/8" X 3/8" X 1/4" tee reducer in the center frame trunk line near the center of the toolbar & install the 1/4" airline labeled RB UP on the tubing harness from the cab controller.



3/8 TEE



BELOW IS AN EXAMPLE OF HOW TO ROUTE THE AIRLINE FROM THE TOOLBAR TO EACH FUNCTION. ZIP TIE THE AIRLINE NEATLY & OUT OF HARMS WAY WHEN IN USE & FOLDING/UNFOLDING MACHINE

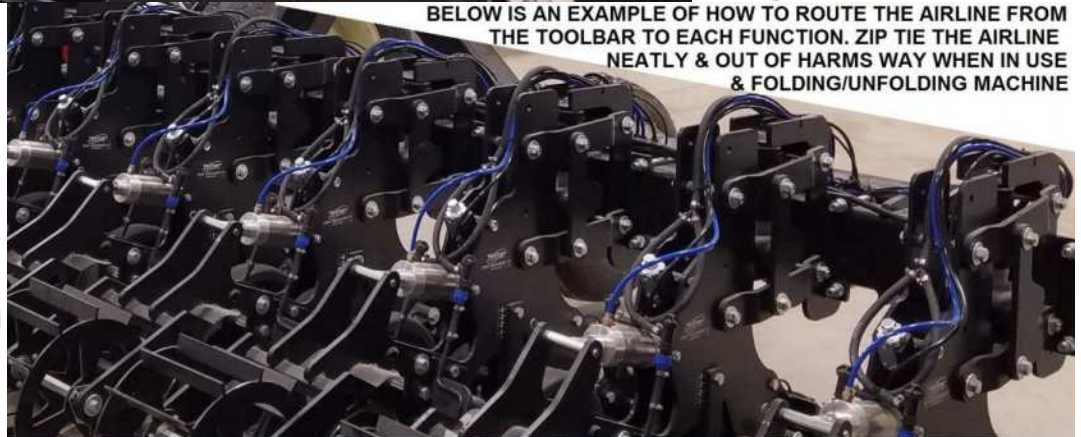
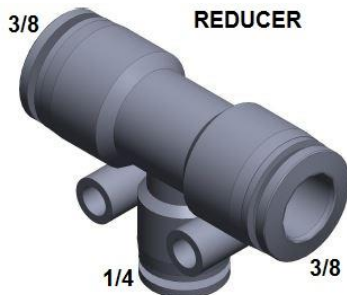

Assembly Instructions

Installation of the Fertilizer Tubes

Below are assembly diagrams for the 4 fertilizer tube kits offered for the 2984 Strip Freshener CC units. An additional clamp on hose is offered for each of the liquid kits to get the fertilizer closer to the soil profile to help keep the fertilizer in the desired location & keep splatter to a minimum. When installing the fertilizer delivery hoses, follow the same route as the airlines. Follow the OEM installation instructions on flow rate, orifices, etc.

2984-082 - RH LIQUID FERTILIZER KIT ASSEMBLY

2984-083 - LH LIQUID FERTILIZER KIT ASSEMBLY

2984-084 - CENTER LIQUID FERTILIZER KIT ASSEMBLY

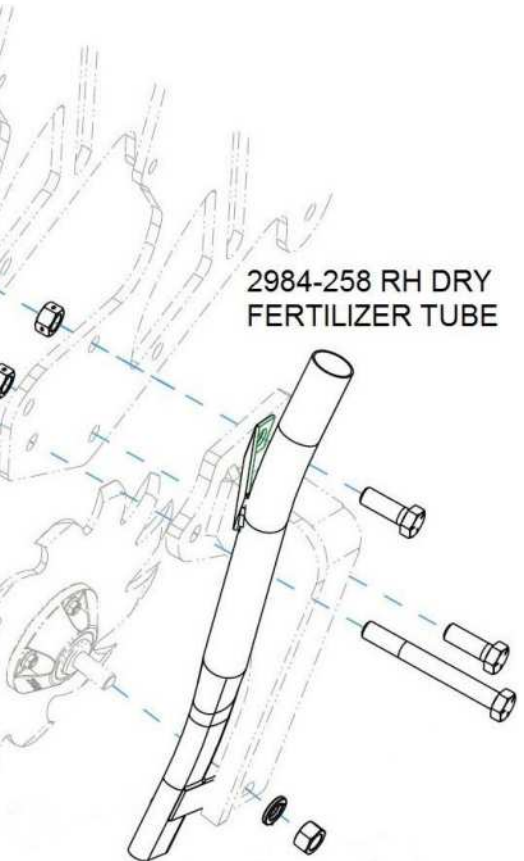
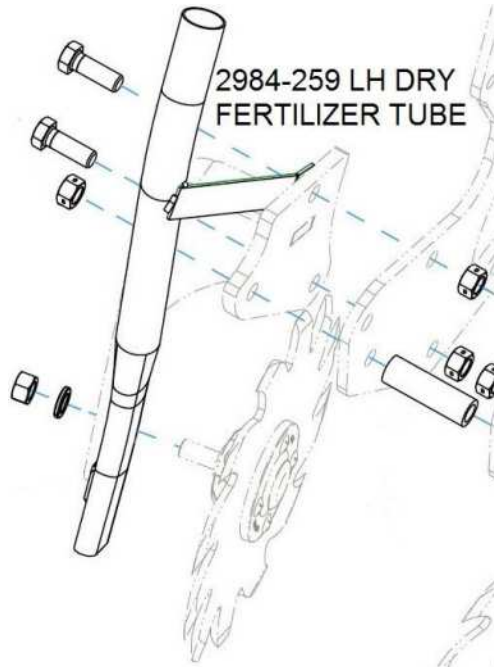
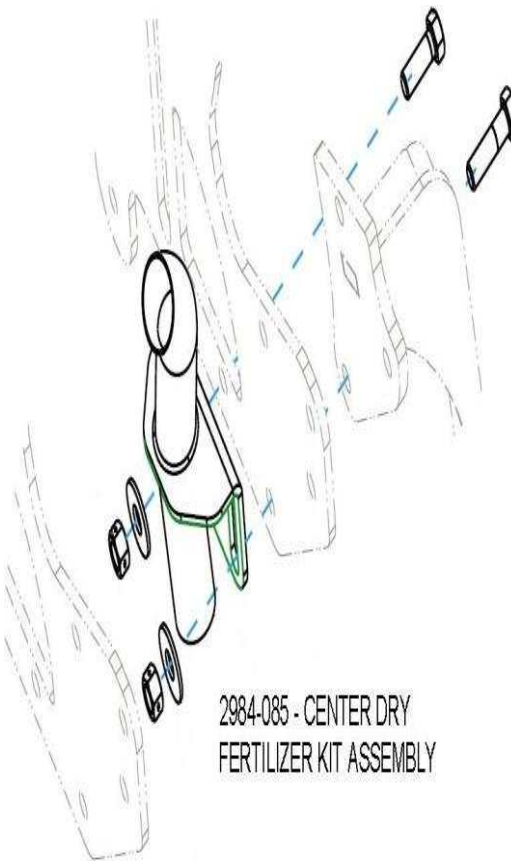
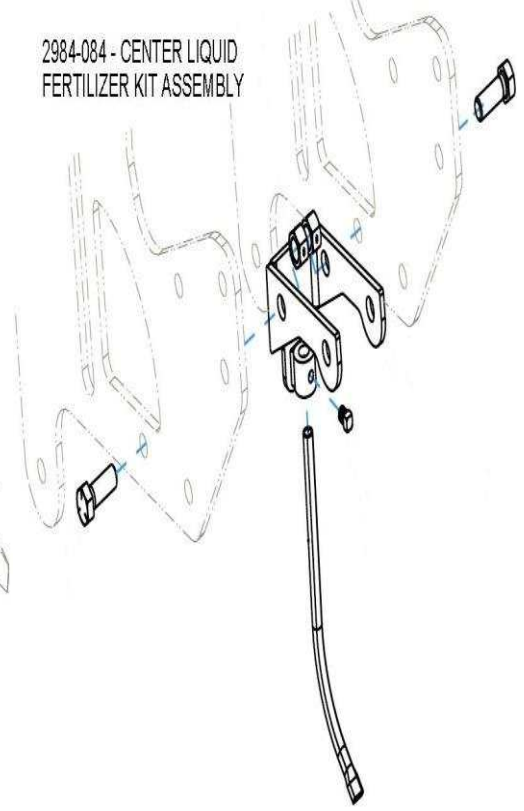
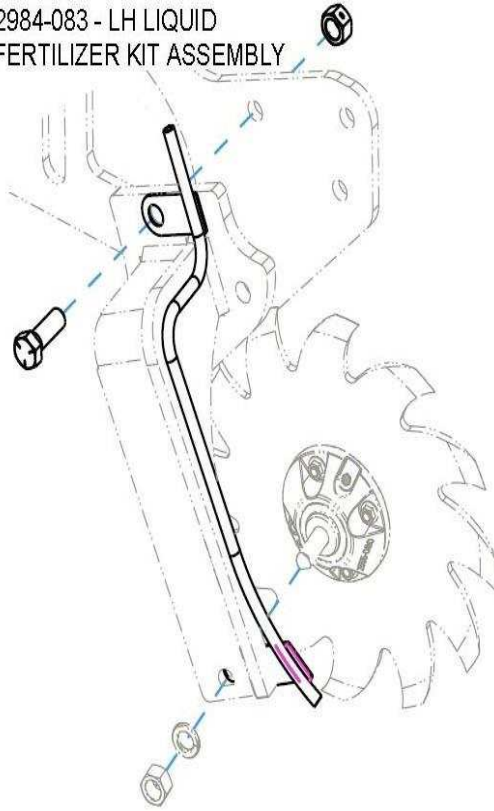
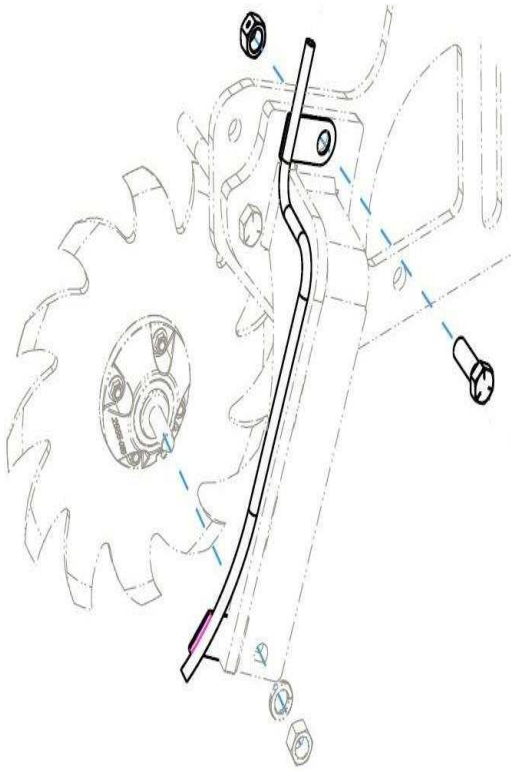

USE EXISTING HARDWARE FOR FERTILIZER TUBE INSTALLATION

2984-085 - CENTER DRY FERTILIZER KIT ASSEMBLY



OPERATION PRECAUTIONS

STOP

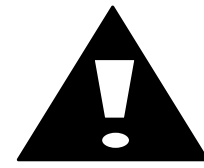

Read this before using the Yetter product.

MACHINE OPERATION

Pneumatic System Check:

Make sure the toolbars compressor source is engaged. Allow the compressor to engage & complete 1 full cycle before applying pressure to any circuit.

Pull the selector valve knob for the row cleaner circuit. Pull the regulator knob (unlock) for the row cleaner up pressure circuit adjustment & turn the knob until ALL row cleaners move to the up position. Push the regulator knob back in to lock in place. Pull the regulator knob for the row unit down force circuit adjustment & turn the knob until the row unit down force gauge reads 50psi on the cab controller. Push the regulator knob back in to lock in place. Pull the selector valve knob for the rolling basket circuit. Pull the regulator knob for the rolling basket up pressure circuit adjustment & turn the knob until ALL rolling baskets move to the up position. Push the regulator knob back in to lock in place. Exit the tractor cab inspecting the bulkhead connector at the hitch & all 3 of the circuits that have air pressure applied (row cleaner up, row unit down force, & rolling basket up). Check for leaks at the tee fittings, air fittings at the cylinders/air bags, & each cylinder/air bag. Repair leaks as needed. Once each of these 3 circuits is leak free, return to the tractor cab.

Push the selector valve for the row cleaner & rolling basket in (all rolling baskets and row cleaners should lower). Pull the regulator knob for the row cleaner down pressure circuit adjustment & turn the knob until the row cleaner gauge reads 50psi. Push the regulator knob back in to lock in place. Pull the regulator knob for the rolling basket down pressure circuit adjustment & turn the knob until the rolling basket gauge reads 50psi. Push the regulator knob back in to lock in place. Exit the tractor cab inspecting the bulkhead connector at the hitch & the down pressure circuit for the row cleaner & rolling baskets. Lift each row cleaner & rolling basket to ensure down pressure in each cylinder is present & equally applied to each row. Check for leaks at the tee fittings, air fittings at the cylinders, & each cylinder. Once all circuits are leak free, return to the tractor cab & return all adjustable circuits to 0psi.

Row Unit Check:

Inspect each individual strip freshener CC unit for loose or damaged hardware. Make sure all pivot points (row unit parallel linkage, row cleaner, rolling basket) travel freely.

IMPORTANT: failure to properly set the frame height and levelness can result in less than successful operation of the Yetter product and may result in damaged equipment. All operators should read and thoroughly understand the instructions given prior to using the Yetter product.

NOTE: **DO NOT** use this product if the toolbar is not adjusted properly!

Leveling the Toolbar:

With the frame lowered to proper operating height (**Usually 22"-26"**) Check to be sure the toolbar is level side to side. **Check** when the toolbar is in the **field** and has been **fully loaded** with fertilizer, etc. Also, a field check with a bubble level on the frame should be made of the hitch height to ensure level operation front to back.

It is important for the toolbar to operate level laterally. Tire pressure must be maintained at pressures specified by the manufacturer.

Field conditions change and will dictate toolbar frame heights. Lower the toolbar and pull forward to allow units to get to desired depth & then recheck toolbar levelness.

Row unit parallel linkage should be parallel to the ground or slightly downhill from front to back.

OPERATION PRECAUTIONS

To ensure the hydraulic compressor motor doesn't exceed the recommended operating RPM level, the hydraulic oil flow control valve has been preset. In some instances, the compressor may run below optimum rpm, or will not reach 145psi of tank pressure read at the gauge on the compressor unit. If this is the case, an adjustment to the flow control valve will need made. Only open the flow control valve enough to allow the compressor to build to 145psi tank pressure read at the gauge on the compressor unit. Opening the flow control too far could cause over speeding and reduced service life of the compressor. Follow the instructions below to make the proper adjustment.

NOTE: Before making any adjustments to the flow control valve, adjust the tractor hydraulic flow fully open. Adjusting the tractor's hydraulic flow will affect the compressor's RPM. The hydraulic motor speed on the hydraulic compressor should not exceed 1350RPM. RPM's on the hydraulic compressor may be checked via the fan blades with an optical tachometer.

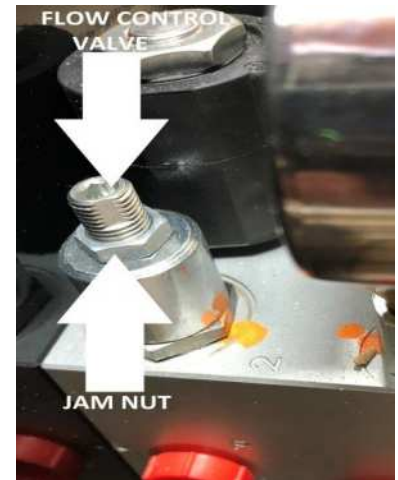

- STEP 1:** Remove the black seal from hydraulic flow control valve and jam nut (2018 and newer will not have seal).
- STEP 2:** Flip the switch to ON on the 2984 Strip Freshener control box & supply hydraulic pressure to the compressor. Make adjustments while hydraulic motor is running. Open tank drain to allow continuous running if necessary.
- STEP 3:** Insert an Allen wrench into flow control valve. 2013 - 05/2018 models use a 5/16, 06/2018 – present use a 3/16.
- STEP 4:** Loosen jam nut by turning counterclockwise. 2013 - 05/2018 models use a 11/16, 06/2018 – present use a 1/2.
- STEP 5:** Using the Allen wrench, **SLIGHTLY** turn the flow control valve counterclockwise (the equivalent to 3 degrees or 1/32 of a turn) to increase the hydraulic motor speed.
- STEP 6:** Hold the Allen wrench in place and tighten the jam nut. Each time an adjustment is made, allow the compressor to build to its potential 145psi shut off mark. If 145psi is not achieved, drain tank pressure until compressor turns on, and make another adjustment. Repeat these steps until 145psi is achieved so that the compressor runs smoothly without struggle. **DO NOT RUN MOTOR ON COMPRESSOR MORE THAN 1350RPM!** RPMs can be checked with an optical tachometer using the fan blades. Once the flow control valve is set properly, hold the Allen wrench in place and tighten the jam nut.

OPERATION

The Tank Pressure should always be above 100psi. If using Yetter Electric/Hydraulic Compressor units, each compressor will shut off at 145psi & engage to recover back to 145psi when tank pressure drops to 120psi. Make sure to have all circuits set at 0psi when setting the toolbar & units for optimum performance begins.

Follow these steps to set the strip freshener CC units to achieve the best results:

- Step 1:** Set the depth (approximate) on each row unit. Adjust screw adjust knob (15/16 wrench) to achieve your preferred depth. Adjustments can be made in 1/4" increments. Rotating the screw adjust knob clockwise will raise the gauge wheels making the units go deeper. Rotating the screw adjust knob counterclockwise will lower the gauge wheels making the units go shallower. The depth decal on the side of each unit is only a reference & NOT an actual depth in inches as to where the unit is set. For example, 3 does not mean 3 inches deep necessarily. Actual depth is determined by how low the cutting couler is below the gauge wheels. Other factors can play in to setting the depth such as row cleaner and rolling basket settings.
- Step 2:** Apply row unit down force until each unit's ride is consistent, smooth, & the correct depth is achieved. **Row unit downforce should never be above 100psi.** Row unit down force may need re-adjusted once the row cleaner is set properly in step 3.
- Step 3:** Fine tune the row cleaners by applying up or down pressure. The row cleaners should only be cleaning residue from the strip & not engaging the soil.
- Step 4:** Apply pressure to the rolling basket cylinder to condition the strip & incorporate fertilizer if applicable. Row unit downforce may need re-adjusted once the rolling basket is set properly.
- Step 5:** Recheck the depth of each row unit & adjust as needed. **(SEE STEP 1)** Check the depth on each row by removing the loose soil until the bottom of each strip is found. For most accurate measurement, remove the residue away from the top of the soil surface next to each strip where measuring & measure from the bottom of each strip to the top of the soil surface.

OPERATION

Cab Control Operation



Row Unit Parallel

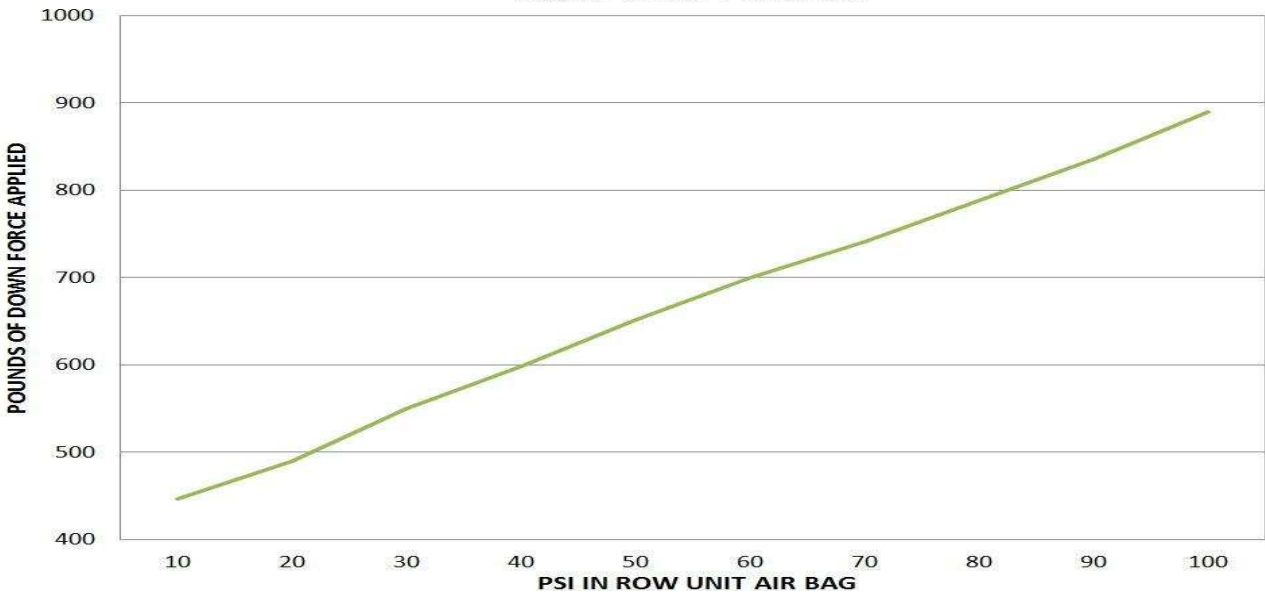

MAINTENANCE

Yetter Compressor Maintenance

WARNING:

 Keep extremities out of the compressor housing when compressor is running, has potential to run, or recently shut off as there are rotating & high temperature parts that may cause injury. Always turn tractor off & disconnect power before performing any maintenance.

LUBRICATION:

Hydraulic compressors are shipped empty of pump lubrication & need oil added before operation. Provided is a 1 Liter bottle of grade 111 synthetic. Add oil until oil level is seen half way up on the sight glass. Recheck oil level on the dipstick. Yetter part # for new bottle is 2940-550.

GUARDS:

Always ensure the housing and guards are in place during operation.

AIR FILTER CARTRIDGE:

Hydraulic Compressor Filter Part # - 2940-549. Electric Compressor Filter Part # - 2940-395, Pre-Cleaner Part # - 2940-396

MAINTENANCE SCHEDULE GUIDE

DAILY

- Check oil level and fill as needed (**hydraulic compressor only**)
- Check air filter cleanliness and clean/replace as needed
- Check hoses for fluid leaks and replace/fix as needed
- Check air lines for air leaks and replace/fix as needed
- Check component parts of the compressor for damage (pressure switch, cooling fan, gauge, etc)
- Open Tank Drain Valve (10 seconds) (**see illustration to the right**) to allow moisture to drain----->

SEASONALLY/200 COMPRESSOR HOURS

- Change compressor oil (**hydraulic compressor only**)
- Change inlet air filter
- Check fluid hoses and air lines for weakness or weathering and replace as needed.
- Check hydraulic fittings for proper connections with no leaks, replace as needed.

Closed



Open

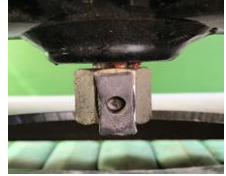

 **FIRST OIL CHANGE SHOULD TAKE PLACE AFTER APPROXIMATELY 50 RUNNING HOURS** (hydraulic compressor only)

CLEANING OR REPLACING THE 2940-106 AIR FILTER

2015 – 2016 MODEL



2017 – PRESENT MODEL



Filter cleanliness is critical to maintain the performance & service life of the compressor. Recommendations for cleaning are DAILY & replace every 200 hours OR at beginning of every planting season. Dirt sucked passed the filter will ruin the pump.

STEP 1: Remove the wing nut & filter cover.

STEP 2: Remove the filter. (If cleaning, tap the filter on a solid surface to remove dirt from the pleats & clean the filter base. **DO NOT USE COMPRESSED AIR TO CLEAN FILTER!**)

STEP 3: Install new or cleaned filter.

STEP 4: Install filter cover & wing nut removed in step 1. **TIGHTEN WING NUT SECURELY**

REPLACING THE COOLING FAN (HYDRAULIC COMPRESSOR)

Remove the filter cover & filter, remove housing (6 bolts), remove hydraulic motor (2 bolts), loosen LH bolt on the end of the shaft, remove the coupler, & replace fan. Reassemble coupler on shaft & tighten LH bolt, reinstall the hydraulic motor, & reassemble the housing, filter, & filter cover. Removing the coupler from the shaft may be difficult. Use a pry bar to hold pressure on the coupler, unthread the LH bolt halfway, & tap with a hammer. Rotate the fan some & repeat this process until coupler breaks loose.

MAINTENANCE



Step 1: Remove the pre-cleaner from the filter cover. Remove the filter cap by turning the cap clockwise.

Step 2: Clean the pre-cleaner & filter. Replace if needed.

Step 3: Install the filter & filter cap, placing the tab in the slots & turning the cap counter clockwise. Make sure the breather hole on the filter cap is facing down. Install the pre-cleaner.

Lubricate all bearings and moving parts as assembled and make certain that they work freely.

WARNING: Never work around the toolbar/implement while in a raised position without using safety lockups.

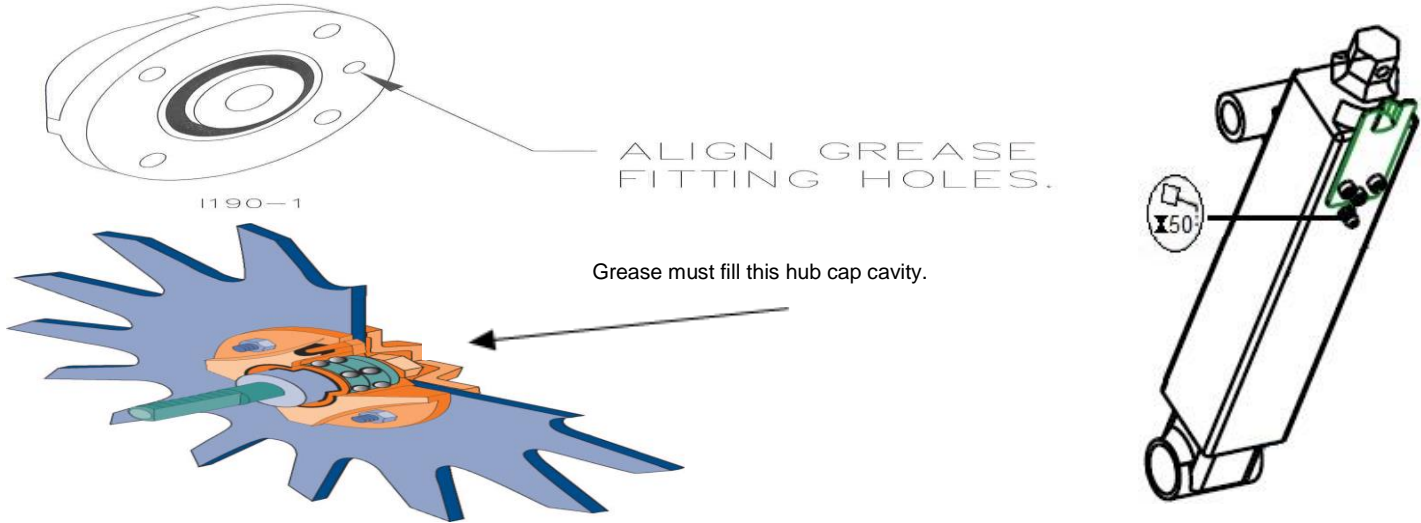

CAUTION: To help prevent serious injury or death to you or other caused by unexpected movement, service machine on a level surface. Lower machine to ground or sufficiently lock or block raised machine before servicing. If machine is connected to a tractor, engage parking brake, place transmission in PARK, shut off engine, & remove the key. If machine is detached from a tractor, block wheel & use shop stands to prevent movement.

CAUTION: Do not clean, lubricate, or adjust a machine while in motion.

Use grease based on NLGI consistency number and the expected air temperature range during the service interval.

Use a **multi-purpose polyurea, water resistant, moderate speed, and NLGI grade #2** grease.

Other greases may be used if they meet the **NLGI Performance Classification: GC-LB**

Important: Some types of grease thickener are not compatible with others. Consult your grease supplier before mixing different types of grease.

Alternative Lubricants

Conditions in certain geographical areas may require special lubricants and lubrication practices which do not appear in the operator's manual. If there are any questions, consult Yetter Manufacturing Co. to obtain the latest information & recommendation.

Part #	Description	Ounces of Grease
2967-404	13" Taper Tooth RM Wheel	1.12 Oz
2967-602	13" SharkTooth RM Wheel	1.12 Oz
2967-186	Floater Wheel Kit w/ RM Wheel	2.08 Oz
2967-596	Heavy Duty or Bevel R.M. Wheel W/Floater Wheel Kit	2.40 Oz

Refilling the cavity with grease on each wheel assembly every 50 hours is required!

All bearings on this unit are sealed bearings. Grease is needed to fill hub cavity to protect seal from damage/contaminants.

Storing Lubricants

Your machine can operate at peak efficiency only if clean lubricants are used. Use clean containers to handle all lubricants. Store them in an area protected from dust, moisture, and other contaminants.

2984-050 STRIP FRESHENER CC PART IDENTIFICATION

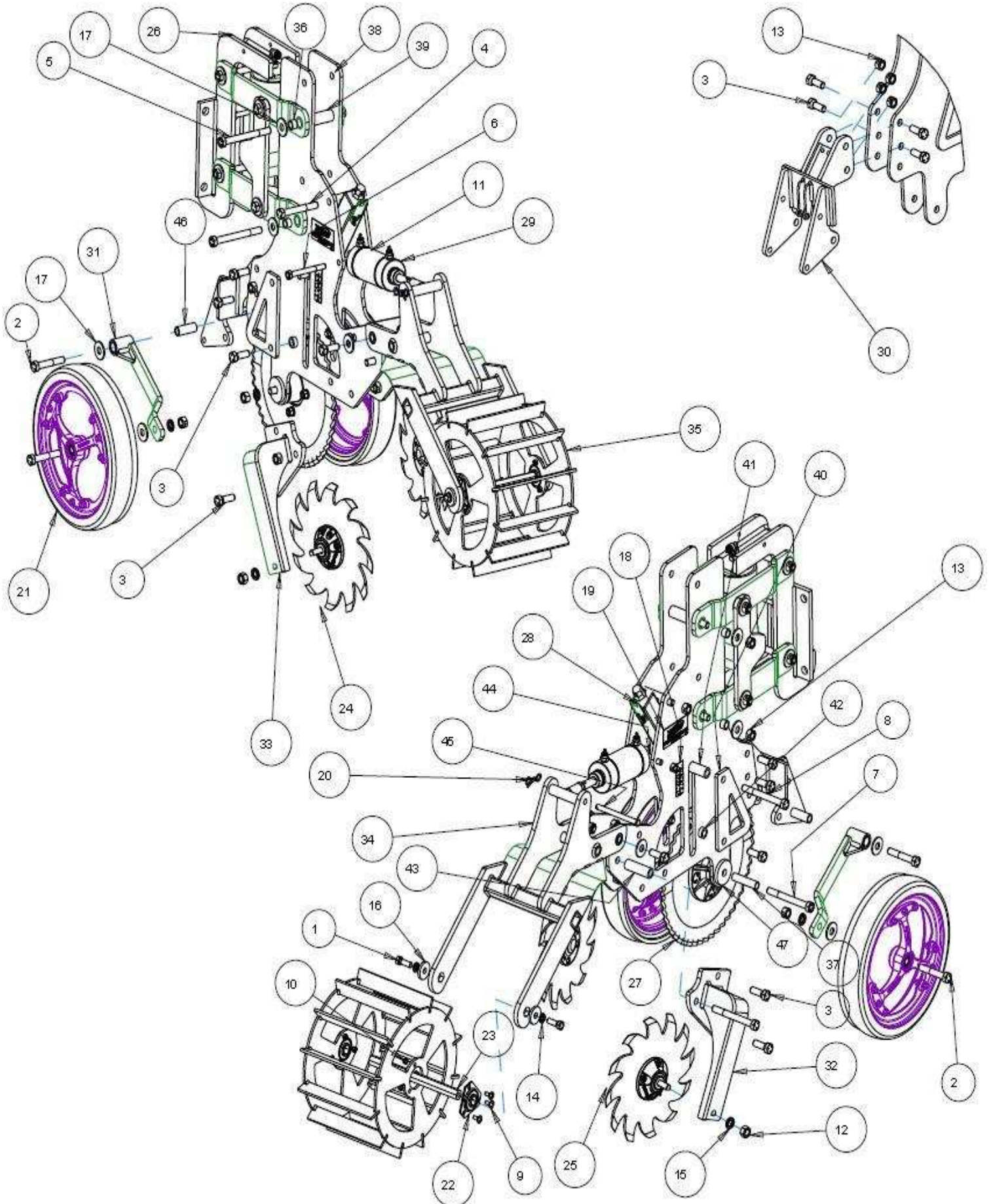

2984-050 STRIP FRESHENER CC PART IDENTIFICATION

ITEM	PART NO.	DESCRIPTION	QTY
1	2502-294	1/2-13 X 1-1/2 HHCS GR5 ZP	2
2	2502-324	5/8-11 X 3-1/2 HHCS GR5 ZP	4
3	2502-331	5/8-11 X 1-3/4 HHCS GR5 ZP	12
4	2502-334	5/8-11 X 4-1/2 HHCS GR5 ZP	1
5	2502-352	5/8-11 X 6 HHCS GRADE 8 ZP	2
6	2502-361	1/2-13 X 4-1/2 HHCS GR8 ZP	1
7	2502-384	5/8-11 X 5.5 HHCS GR8 ZP	1
8	2502-397	5/8-11 X 5 1/2 HHCS GR5 ZP	2
9	2505-205	5/16-18 X 3/4 CARBOLT G5 ZP	6
10	2520-205	5/16-18 LOCK HEX NUT, GR A, ZP	6
11	2520-357	1/2-13 LOCK HEX NUT, GR A, ZP	1
12	2520-452	5/8-11 HEXNUT ZP	3
13	2520-459	5/8-11 LOCK HEX NUT, GR B, ZP	21
14	2525-352	1/2 MED LOCKWASHER ZP.	2
15	2525-451	5/8 MED. LOCKWASHER ZP.	5
16	2526-402	9/16ID X 1-3/4 OD X 1/4MBZP	2
17	2526-451	5/8 STD FLATWASHER ZP	12
18	2565-350	ADJUSTMENT DECAL	2
19	2565-356	STRIP FRESHENER DECAL	2
20	2570-448	.120 BOWTIE LOCKING COTTER ZP	1
21	2570-786	3" X 16" GAUGE WHEEL, TRI-SPOKE	2
22	2570-787	FLANGED BEARING ASSEMBLY, 7/8" HEX ID	2
23	2940-634	HEX SHAFT	1
24	2966-140-ST	SHARKTOOTH ASSY,RH,3" D-BOLT	1
25	2966-141-ST	SHARKTOOTH ASSY,LH,3" D-BOLT	1
26	2984-132	TOOLBAR MOUNT W/ARMS	1
27	2984-143	RIPPLE BLADE ASSEMBLY	1
28	2984-144	DEPTH ADJUST ASSEMBLY	1
29	2984-153	AIR CYLINDER ASSEMBLY	1
30	2984-241	RM ARM MOUNT W.A.	1
31	2984-247	GAUGE WHEEL ARM W.A.	2
32	2984-248	R.H. SHARKTOOTH MOUNT W.A.	1
33	2984-249	L.H. SHARKTOOTH MOUNT W.A.	1
34	2984-250	ROLLING BASKET MOUNT W.A.	1
35	2984-251	ROLLING BASKET W.A.	1
36	2984-330	9/16" BUSHING CHROME PLATED	6
37	2984-455	BEARING BORE ADAPTER, ZP	1
38	2984-462	BODY SIDE PLATE	2
39	2984-463	PARALLEL ARM BUSHING	2
40	2984-468	DEPTH STOP	2
41	2984-469	TOP DEPTH STOP BUSHING	1
42	2984-470	DEPTH ADJ LOWER BUSHING	2
43	2984-479	CROSS BUSHING	1
44	2984-495	STRUT BUSHING SHORT	2
45	2984-497	AIR CYLINDER ROD PIN	1
46	2984-498	GAUGE WHEEL PIVOT BUSHING	2
47	2984-501	WASHER, .688ID X 2.50 OD X .375THK	2

2984-132 PARALLEL LINKAGE ASSEMBLY PART IDENTIFICATION

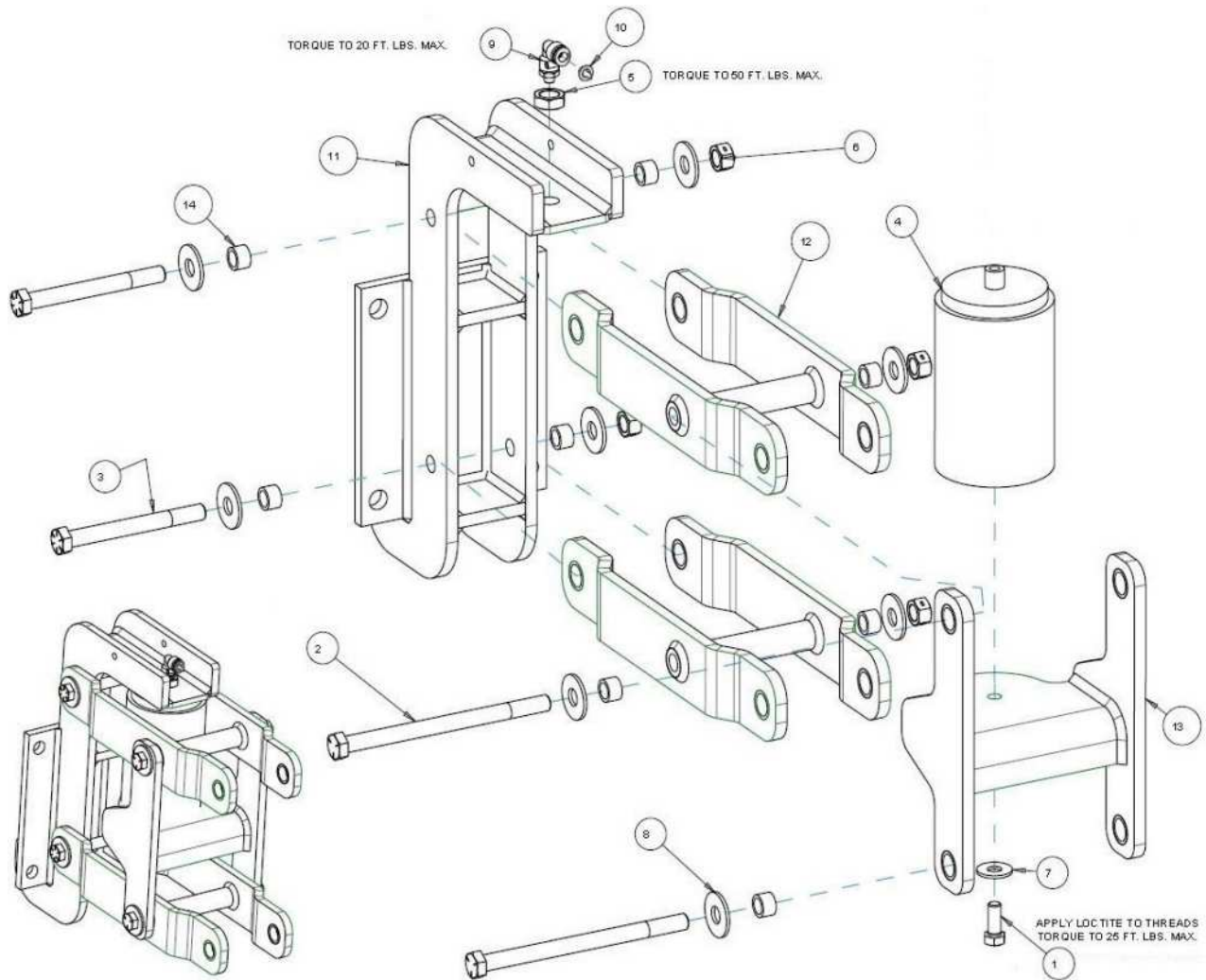

ITEM	PART NO.	DESCRIPTION	QTY
1	2502-293	1/2-13 X 1-1/4 HHCS GR5 ZP	1
2	2502-333	5/8-11 X 9 HHCS GR. 5 ZP	2
3	2502-352	5/8-11 X 6 HHCS GRADE 8 ZP	2
4	2515-304	AIR BAG	1
5	2520-312	3/4-16 JAM HEX NUT ZP	1
6	2520-459	5/8-11 LOCK HEX NUT, GR B, ZP	4
7	2526-351	1/2 STANDARD FLATWASHER ZP	1
8	2526-451	5/8 STD FLATWASHER ZP	8
9	2940-381	3/8 PC X 1/8 BSPP O-RING	1
10	2940-389	RUBBER AIR BAG PLUG	1
11	2984-242	TOOLBAR MOUNT WELDMENT	1
12	2984-243	UPPER PARALLEL ARM WA	2
	2984-500	ARM PIVOT SLEEVE	4
13	2984-244	AIR BAG BASE WELDMENT	1
14	2984-330	9/16" BUSHING CHROME PLATED	8

NARROW ROW CLEANER ASSEMBLY PART IDENTIFICATION

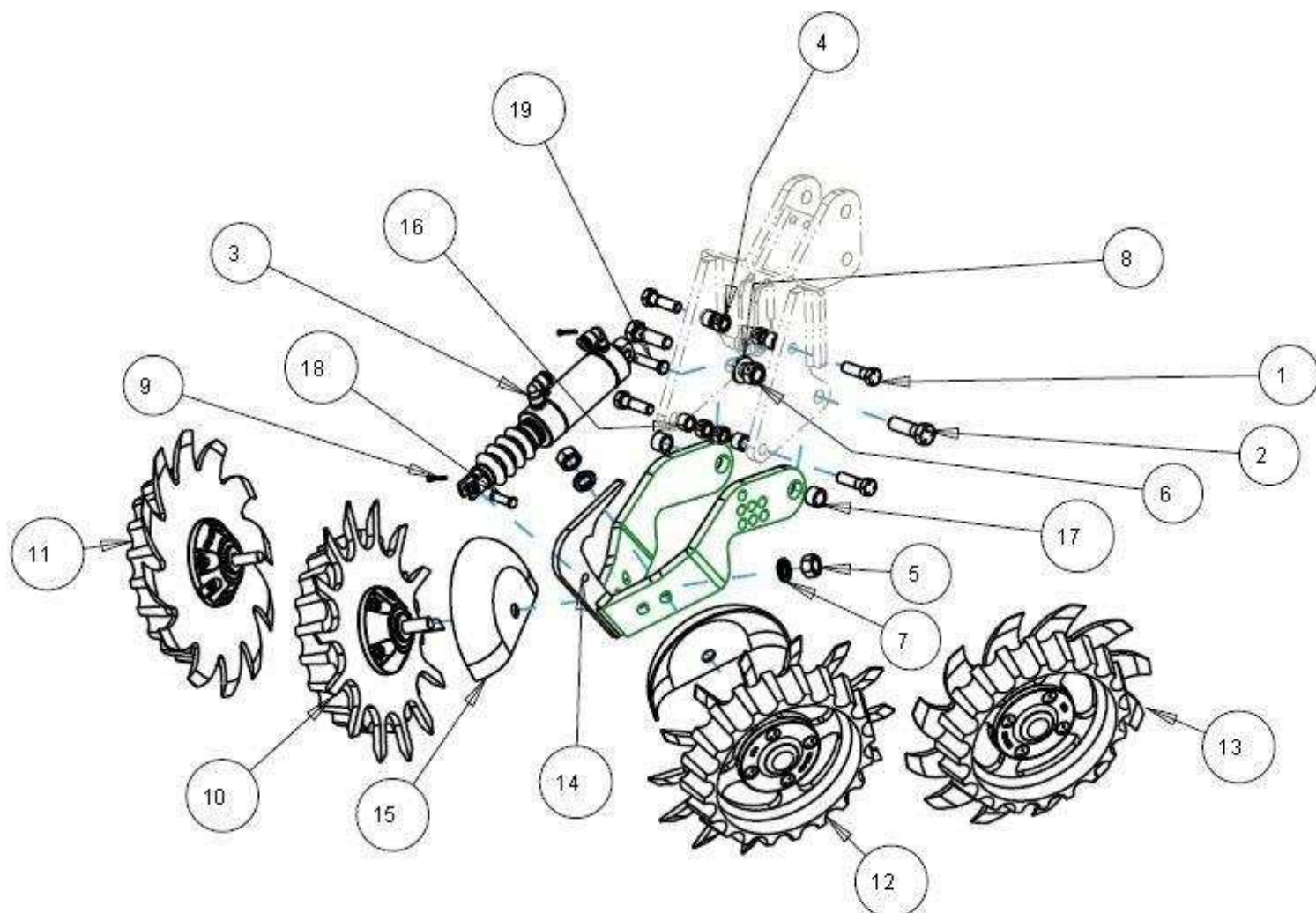

ITEM	PART NO.	DESCRIPTION	QTY
1	2502-317	1/2-13 X 1-3/4 HHCS GR5 ZP	4
2	2502-391	5/8-11 X 2 HHCS GR 5 ZP	2
3	2515-305	CLEAN SWEEP CYLINDER	1
4	2520-357	1/2-13 LOCK HEX NUT, GR A, ZP	4
5	2520-452	5/8-11 HEXNUT ZP	2
6	2520-459	5/8-11 LOCK HEX NUT, GR B, ZP	2
7	2525-451	5/8 MED. LOCKWASHER ZP.	2
8	2526-453	5/8 SAE FLATWASHER ZP	2
9	2531-107	1/8 X 1 COTTER PIN ZP	2
10	2966-140-BW-FW	BEVELWL ASSY,RH,3"D-BOLT FWL	1
11	2966-140-ST-FW	SHRKTH ASSY,RH,3"D-BOLT FLT WL	1
12	2966-141-BW-FW	BEVELWL ASSY,LH,3"D-BOLT FTWL	1
13	2966-141-ST-FW	SHRKTH ASSY,LH,3"D-BOLT FLT WL	1
14	2966-291	ARM, W, NARROW TITAN	1
15	2967-392	SHIELD, RM-PAINTED	2
16	2967-622	9/16" SPACER ZP	4
17	6000-335	9/16" BUSHING	2
18 & 19	2984-154	PIN KIT FOR AIR CYLINDER	1

WIDE ROW CLEANER ASSEMBLY PART IDENTIFICATION

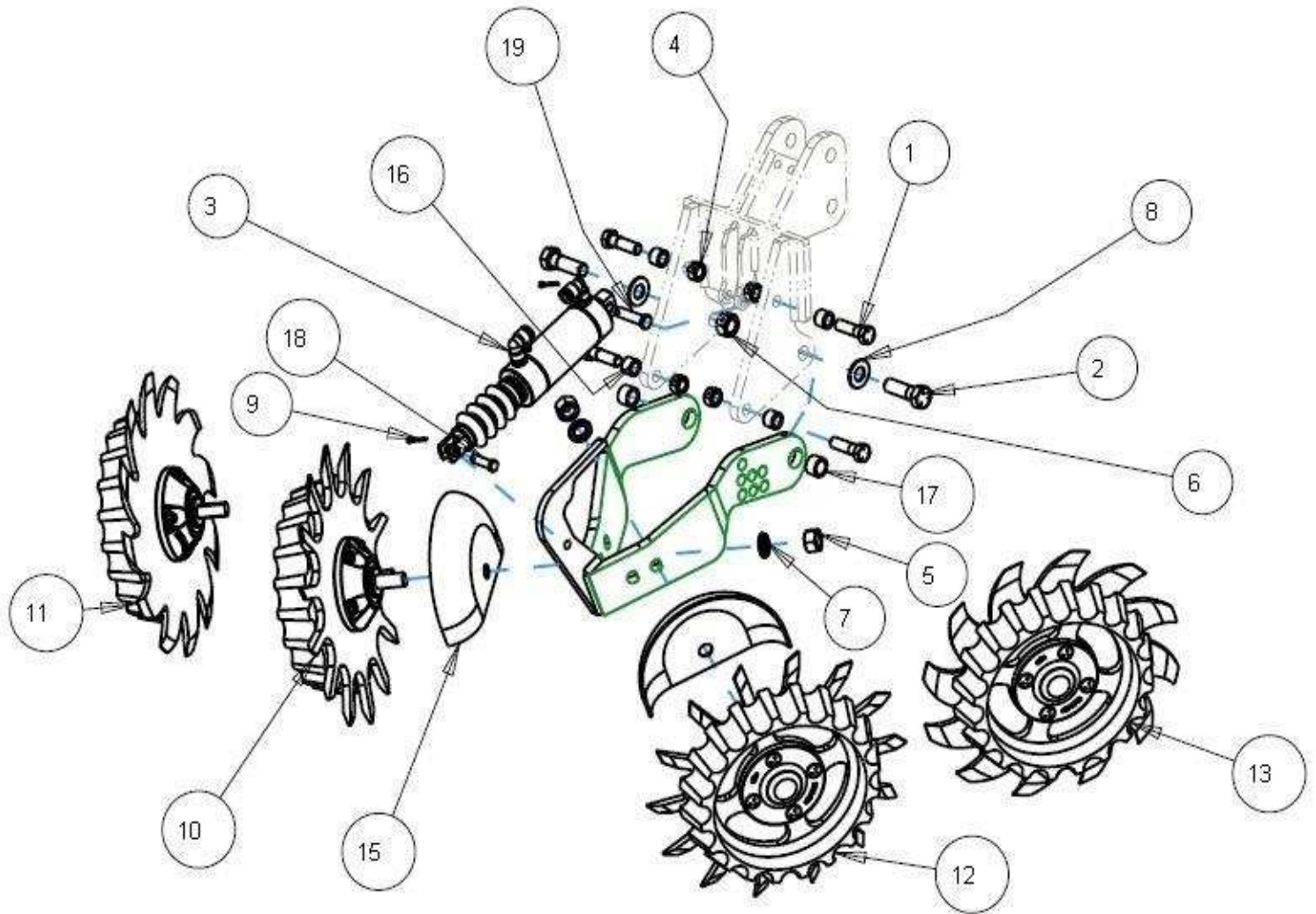

ITEM	PART NO.	DESCRIPTION	QTY
1	2502-317	1/2-13 X 1-3/4 HHCS GR5 ZP	4
2	2502-391	5/8-11 X 2 HHCS GR 5 ZP	2
3	2515-305	CLEAN SWEEP CYLINDER	1
4	2520-357	1/2-13 LOCK HEX NUT, GR A, ZP	4
5	2520-452	5/8-11 HEXNUT ZP	2
6	2520-459	5/8-11 LOCK HEX NUT, GR B, ZP	2
7	2525-451	5/8 MED. LOCKWASHER ZP.	2
8	2526-453	5/8 SAE FLATWASHER ZP	2
9	2531-107	1/8 X 1 COTTER PIN ZP	2
10	2966-140-BW-FW	BEVELWL ASSY,RH,3"D-BOLT FWL	1
11	2966-140-ST-FW	SHRKTH ASSY,RH,3"D-BOLT FLT WL	1
12	2966-141-BW-FW	BEVELWL ASSY,LH,3"D-BOLT FTWL	1
13	2966-141-ST-FW	SHRKTH ASSY,LH,3"D-BOLT FLT WL	1
14	2966-292	ARM, W, WIDE TITAN	1
15	2967-392	SHIELD, RM-PAINTED	2
16	2967-622	9/16" SPACER ZP	4
17	6000-335	9/16" BUSHING	2
18 & 19	2984-154	PIN KIT FOR AIR CYLINDER	1

GAUGE WHEEL ASSEMBLY PARTS IDENTIFICATION

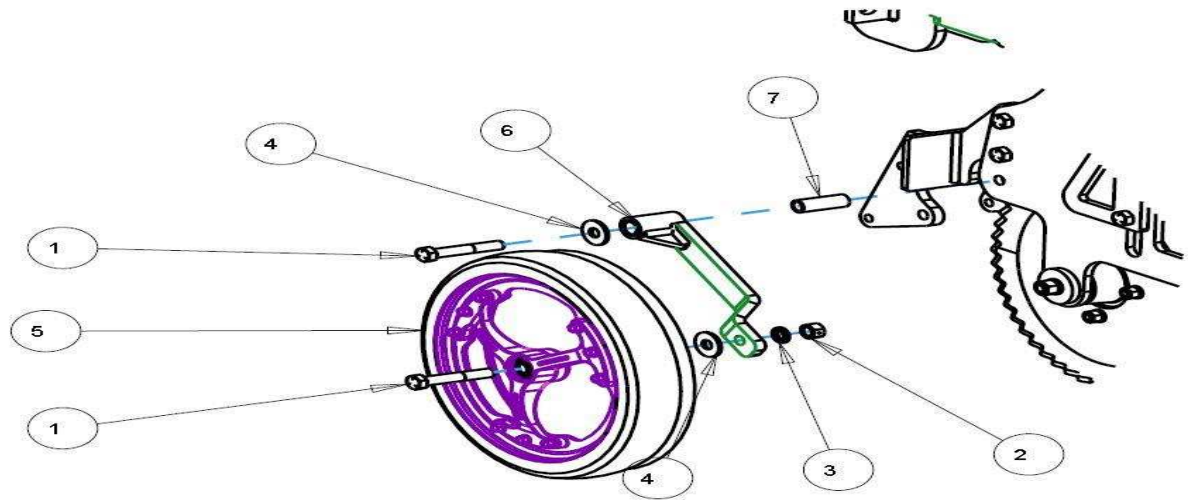

ITEM	PART NO.	DESCRIPTION	QTY
1	2502-324	5/8-11 X 3-1/2 HHCS GR5 ZP	4
2	2520-459	5/8-11 LOCK HEX NUT, GR B, ZP	21
3	2525-451	5/8 MED. LOCKWASHER ZP.	5
4	2526-451	5/8 STD FLATWASHER ZP	12
5	2570-786	3" X 16" GAUGE WHEEL, TRI-SPOKE	2
6	2984-247	GAUGE WHEEL ARM W.A.	2
7	2984-498	GAUGE WHEEL PIVOT BUSHING	2

SHARKTOOTH MOUNT ASSEMBLY PART IDENTIFICATION

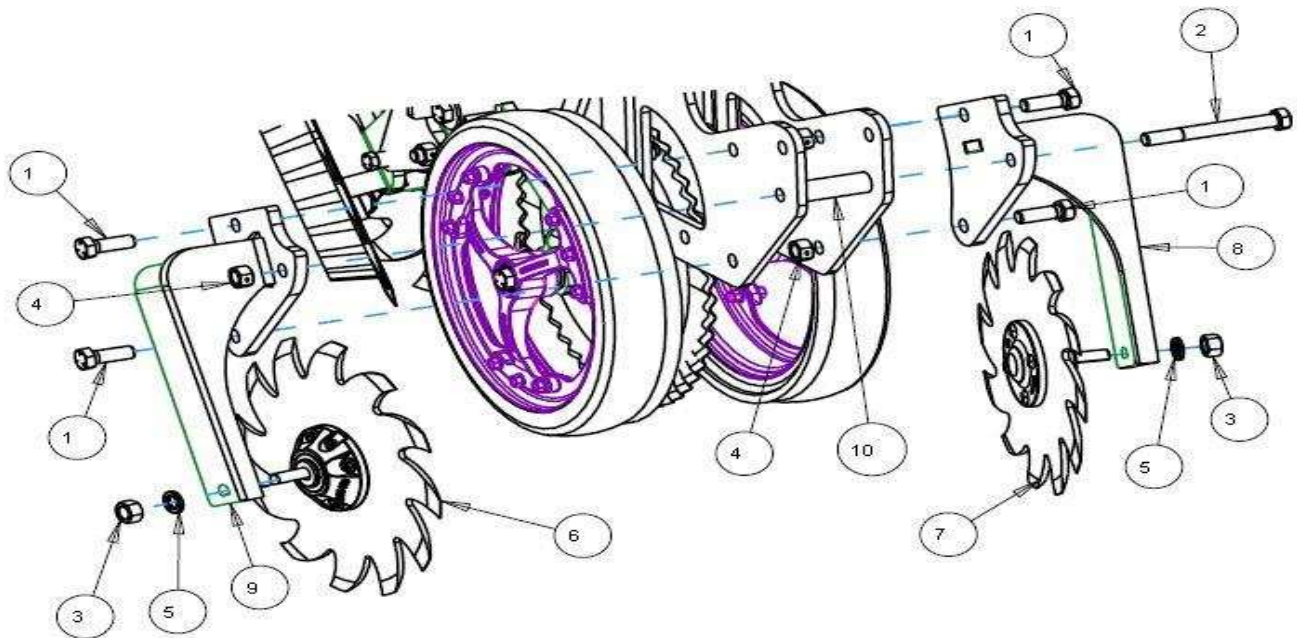

ITEM	PART NO.	DESCRIPTION	QTY
1	2502-331	5/8-11 X 1-3/4 HHCS GR5 ZP	12
2	2502-397	5/8-11 X 5 1/2 HHCS GR5 ZP	2
3	2520-452	5/8-11 HEXNUT ZP	3
4	2520-459	5/8-11 LOCK HEX NUT, GR B, ZP	21
5	2525-451	5/8 MED. LOCKWASHER ZP.	5
6	2966-140-ST	SHARKTOOTH ASSY,RH,3" D-BOLT	1
7	2966-141-ST	SHARKTOOTH ASSY,LH,3" D-BOLT	1
8	2984-248	R.H. SHARKTOOTH MOUNT W.A.	1
9	2984-249	L.H. SHARKTOOTH MOUNT W.A.	1
10	2984-479	CROSS BUSHING	1

ROLLING BASKET ASSEMBLY PART IDENTIFICATION

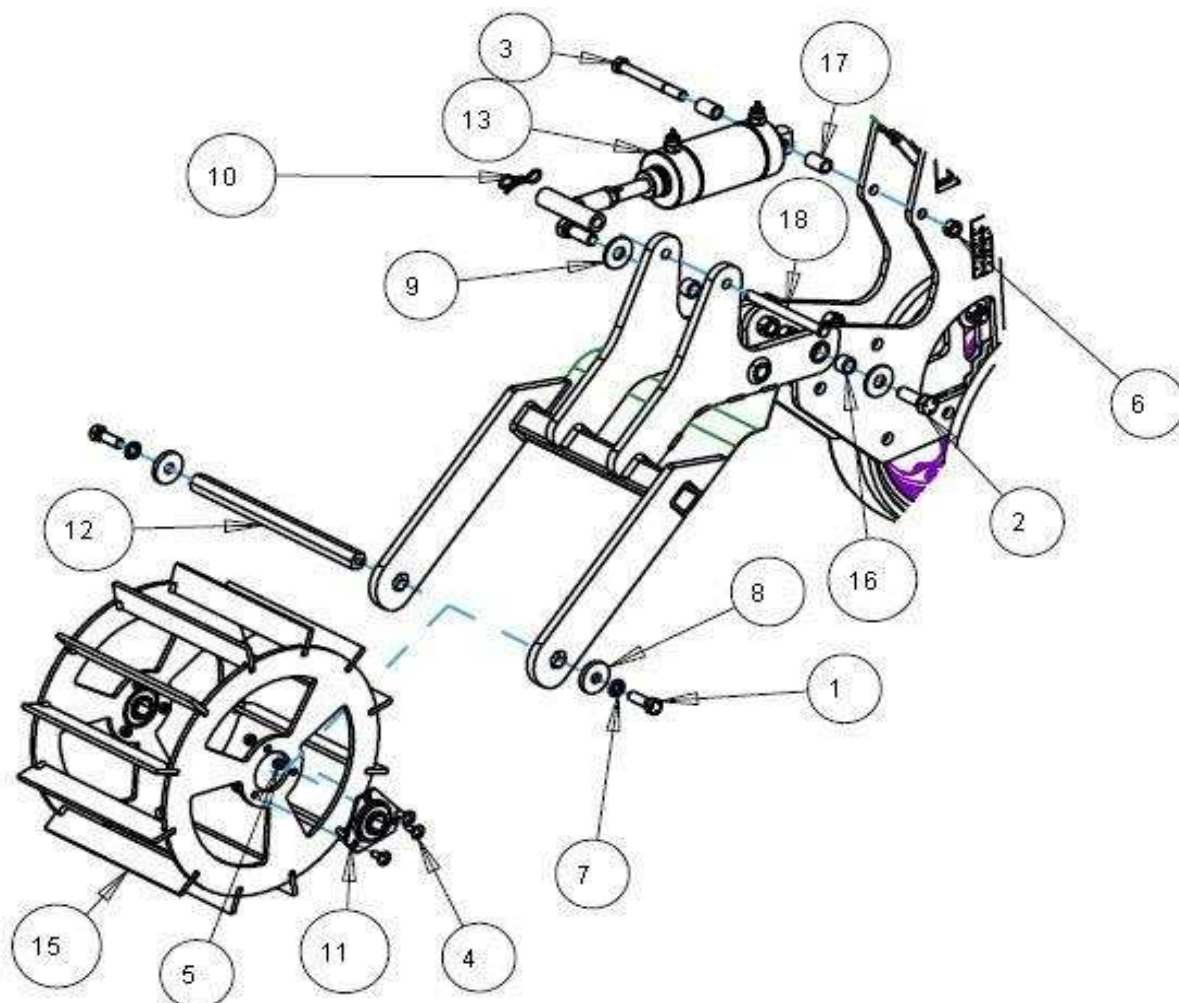

ITEM	PART NO.	DESCRIPTION	QTY
1	2502-294	1/2-13 X 1-1/2 HHCS GR5 ZP	2
2	2502-331	5/8-11 X 1-3/4 HHCS GR5 ZP	12
3	2502-361	1/2-13 X 4-1/2 HHCS GR8 ZP	1
4	2505-205	5/16-18 X 3/4 CARBOLT G5 ZP	6
5	2520-205	5/16-18 LOCK HEX NUT, GR A, ZP	6
6	2520-357	1/2-13 LOCK HEX NUT, GR A, ZP	1
7	2525-352	1/2 MED LOCKWASHER ZP.	2
8	2526-402	9/16ID X 1-3/4 OD X 1/4MBZP	2
9	2526-451	5/8 STD FLATWASHER ZP	12
10	2570-448	.120 BOWTIE LOCKING COTTER ZP	1
11	2570-787	FLANGED BEARING ASSEMBLY, 7/8" HEX ID	2
12	2940-634	HEX SHAFT	1
13	2984-153	AIR CYLINDER ASSEMBLY	1
14	2984-250	ROLLING BASKET MOUNT W.A.	1
15	2984-251	ROLLING BASKET W.A.	1
16	2984-330	9/16" BUSHING CHROME PLATED	6
17	2984-495	STRUT BUSHING SHORT	2
18	2984-497	AIR CYLINDER ROD PIN	1

ROW CLEANER MOUNT ASSEMBLY PART IDENTIFICATION

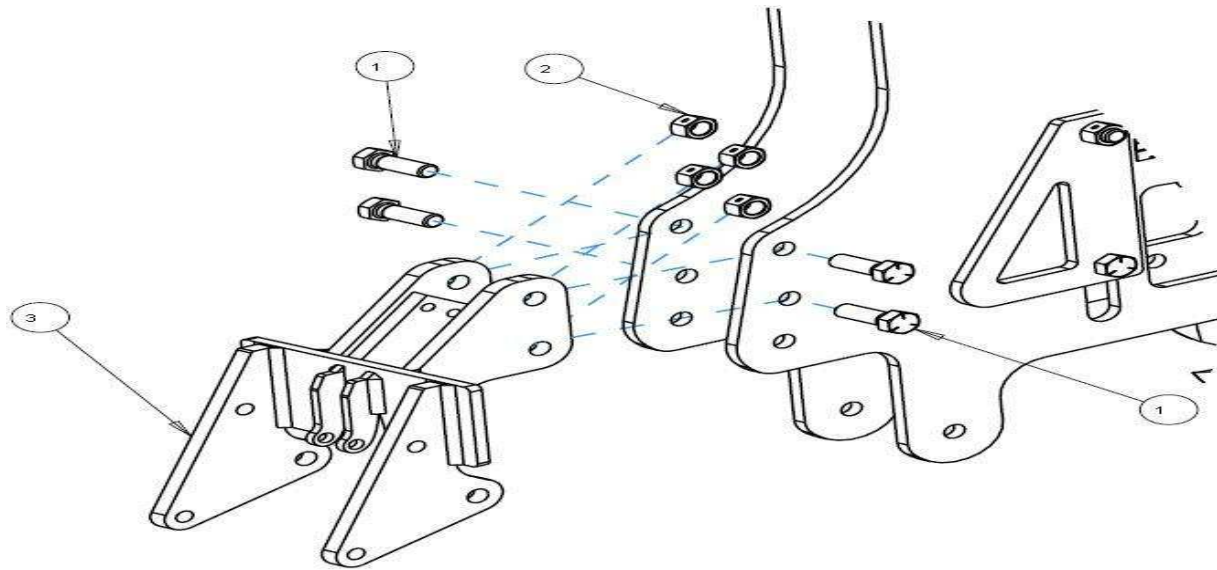

ITEM	PART NO.	DESCRIPTION	QTY
1	2502-331	5/8-11 X 1-3/4 HHCS GR5 ZP	12
2	2520-459	5/8-11 LOCK HEX NUT, GR B, ZP	21
3	2984-241	RM ARM MOUNT W.A.	1

DEPTH STOP ADJUST ASSEMBLY PART IDENTIFICATION

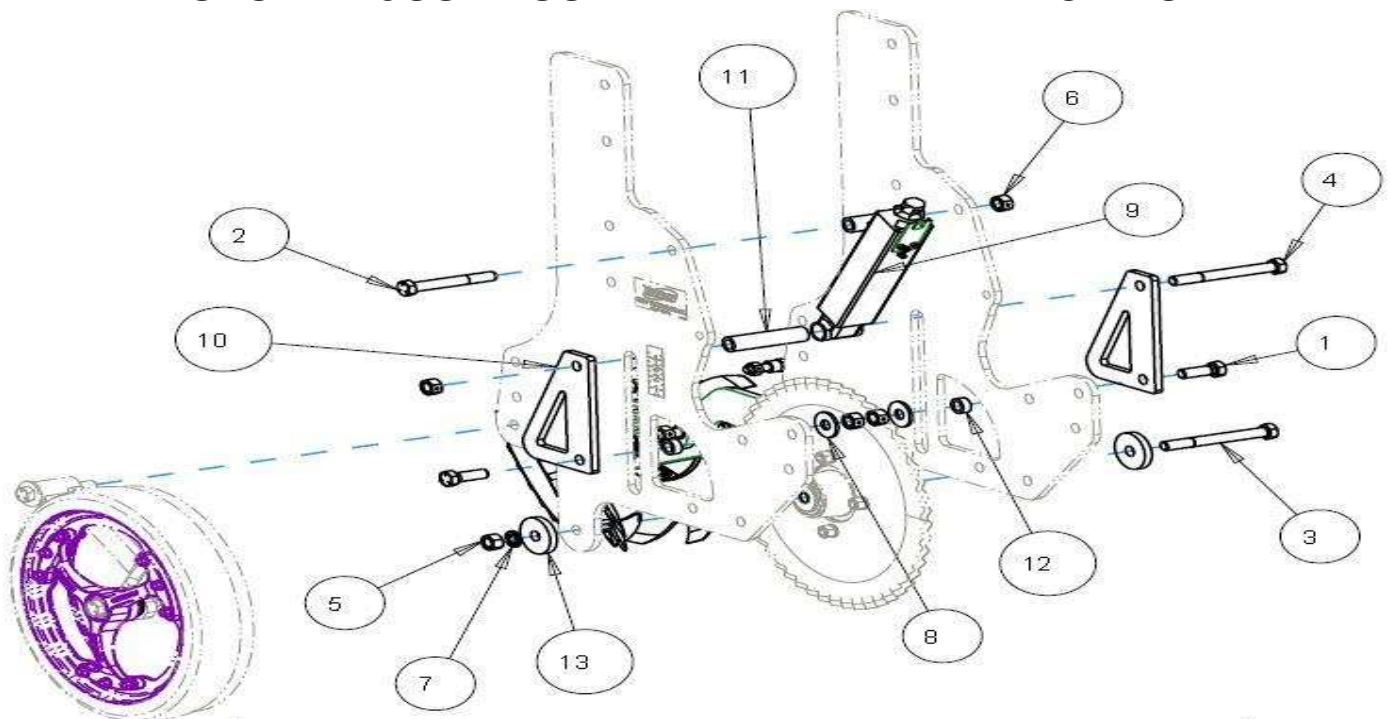

ITEM	PART NO.	DESCRIPTION	QTY
1	2502-331	5/8-11 X 1-3/4 HHCS GR5 ZP	12
2	2502-334	5/8-11 X 4-1/2 HHCS GR5 ZP	1
3	2502-384	5/8-11 X 5.5 HHCS GR8 ZP	1
4	2502-397	5/8-11 X 5 1/2 HHCS GR5 ZP	2
5	2520-452	5/8-11 HEXNUT ZP	3
6	2520-459	5/8-11 LOCK HEX NUT, GR B, ZP	21
7	2525-451	5/8 MED. LOCKWASHER ZP.	5
8	2526-451	5/8 STD FLATWASHER ZP	12
9	2984-144	DEPTH ADJUST ASSEMBLY	1
10	2984-468	DEPTH STOP	2
11	2984-469	TOP DEPTH STOP BUSHING	1
12	2984-470	DEPTH ADJ LOWER BUSHING	2
13	2984-501	WASHER, .688ID X 2.50 OD X .375THK.	2

2966-140 & 2966-141 WHEEL ASSEMBLY PART IDENTIFICATION

RESIDUE MANAGER WHEEL ASSEMBLY
 (LEFT HAND WHEEL ASSEMBLY IS SHOWN)
 (FLIPPING THE WHEEL (ITEM 8) WILL MAKE
 A RIGHT HAND WHEEL ASSEMBLY
 EXCEPT FOR BEVELED WHEELS)

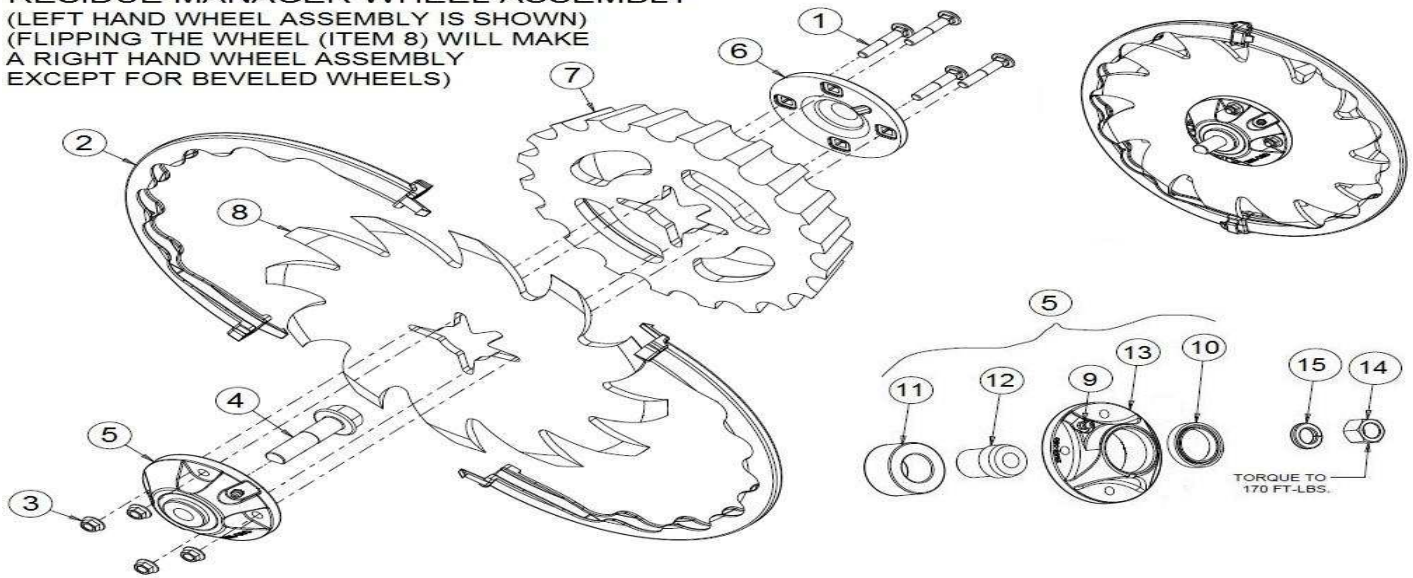

Item	Part Number	Description	Qty
1	2505-207	5/16-18 X 1 1/4 CAR BLT GR5 ZP	4
	2505-208	5/16-18 X 1 1/2 CAR BLT GR5 ZP (For use with Heavy Duty Wheel)	4
	2505-209	5/16-18 X 1 3/4 CAR BLT GR5 ZP (For use with Floater Wheel)	4
2	2515-562	13" WHEEL COVER, BLACK	2
3	2520-206	5/16 - 18 FLANGE LOCK NUT	4
4	2570-740	D-BOLT, FLANGED, 5/8-11 X 2.812 GR 8 (ROW CLEANERS ONLY)	1
	2570-766	D-BOLT, FLANGED, 5/8 - 11 X 2.562 GR 8 (FOR COULTER/COMBO WHEELS)	1
5	2965-128	HUB AND BEARING ASSEMBLY, 4 BOLT	1
6	2965-352	HUB CAP CASTING, 4 BOLT, BLACK	1
7	2967-555	FLOATER WHEEL (ONLY USED ON ROW CLEANER WHEEL ASSEMBLIES)	1
8	2967-404	13" TAPER TOOTH SPOKE WHEEL	1
	2967-596	3/8 TAPER TOOTH SPOKE WHEEL	1
	2967-602	13" SHARK TOOTH WHEEL	1
	6200-350	13" BEVELED WHEEL, LH	1
	6200-351	13" BEVELED WHEEL, RH	1
9	2533-110	1/2" SELF TAP ZERK (NOT SHOWN)	1
10	2550-069	SEAL, TRIPLE LIP, NTI# 1812-5	1
11	2570-594	BEARING, 2 ROW, NTN DF0654L	1
12	2570-715	BEARING INSERT, TRASHMASTER	1
13	2965-351	HUB CAST, MACHINED, 4 BOLT	1
14	2520-452	5/8-11 HEX NUT	1
15	2525-451	5/8 LOCKWASHER	1

2984-143 RIPPLE BLADE ASSEMBLY PART IDENTIFICATION

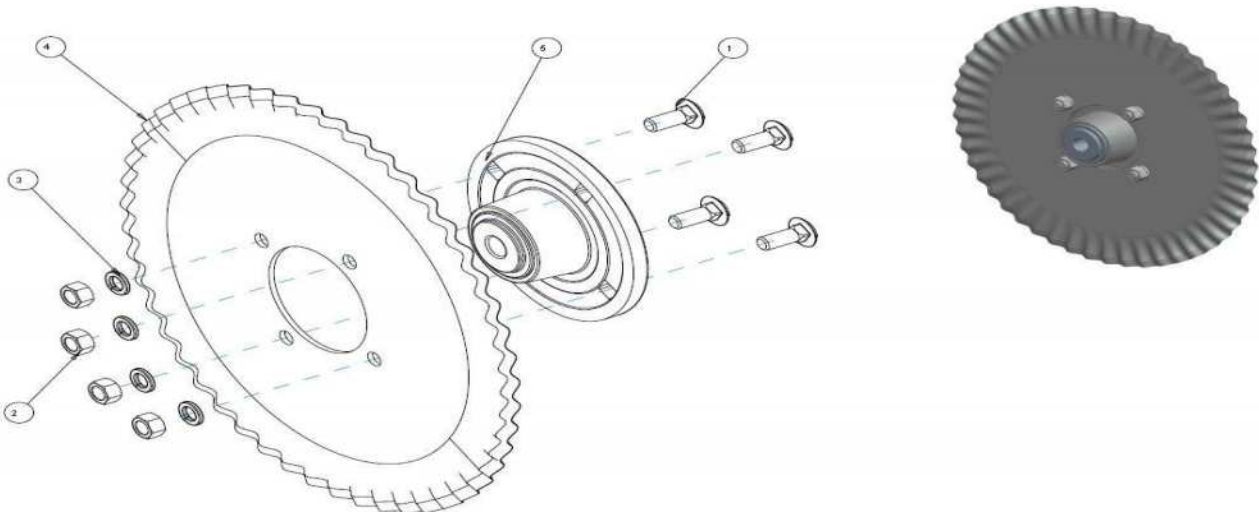

Item	Part Number	Description	Qty
1	2505-337	1/2 - 13 X 1 1/4 CARRIAGE BOLT GR 5 ZP	4
2	2520-352	1/2 - 13 HEX NUT ZP	4
3	2525-352	1/2 MEDIUM LOCK WASHER ZP	4
4	2571-161	.157 X 15.94" RIPPLE BLADE	1
5	2984-152	HUB ASSEMBLY	1

HUB ASSEMBLY PART IDENTIFICATION

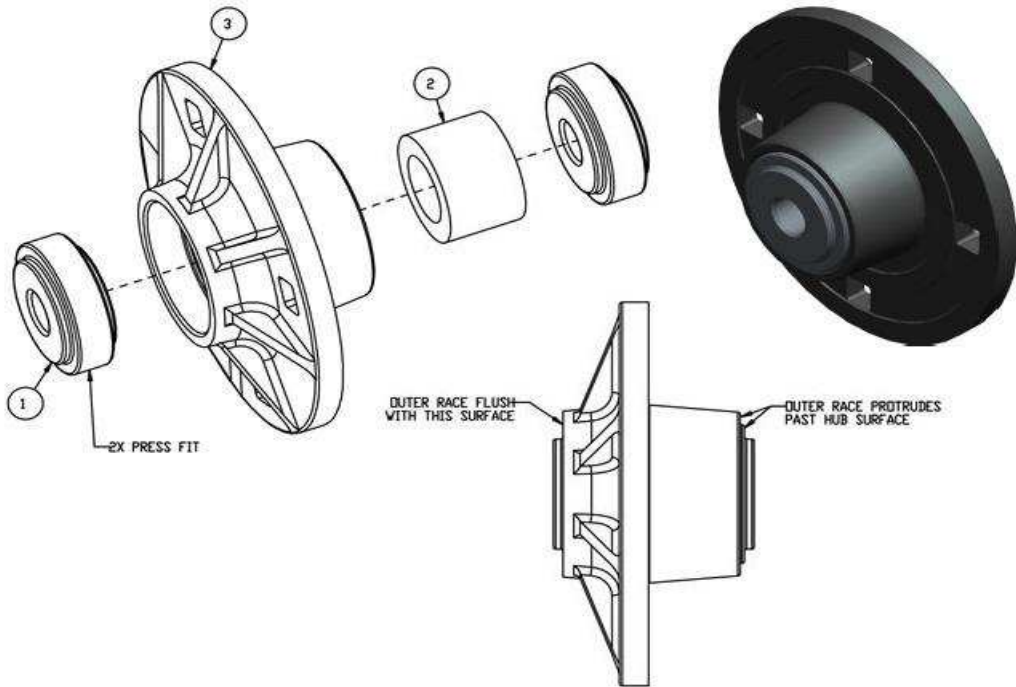

ITEM	PART NO.	DESCRIPTION	QTY
1	2570-575	BEARING, MARKER DISC	2
2	2984-456	BEARING SPACER	1
3	2984-457	STRIP FRESHENER HUB, MACHINED	1

SCREW ADJUST ASSEMBLY PART IDENTIFICATION

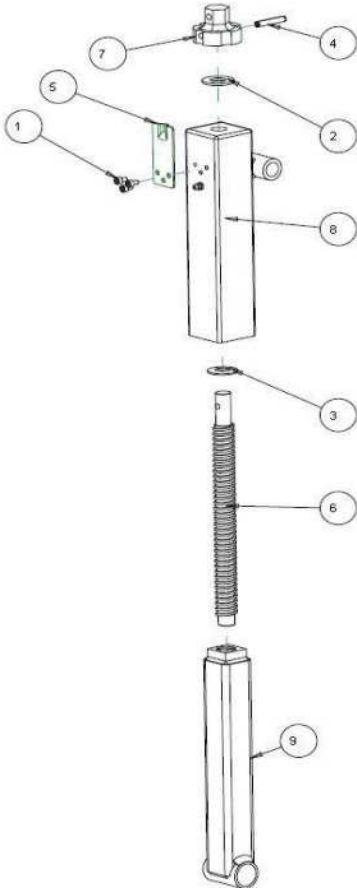

ITEM	PART NO.	DESCRIPTION	QTY
1	2510-102	#10-32X.31HSHCPS ZP W/TRDLCK	3
2	2526-453	5/8 SAE FLATWASHER ZP	1
3	2526-456	BVLE DISC SPRG .630 IDX 1.25OD	1
4	2530-158	PIN, COILED SPRING, 1/4X1-1/2, HD	1
5	2967-652	DETENT PLATE, ZP	1
6	2967-657	ACME SCREW	1
7	2967-699	ADJUSTMENT KNOB (9/07)	1
8	2984-245	DEPTH ADJUST HOUSING W.A.	1
	2533-110	1/4-28 ZERK STRAIGHT SELF-TAP	1
9	2984-246	INNER TUBE W.A.	1

PARTS IDENTIFICATION

2984-082 - RH LIQUID FERTILIZER KIT ASSEMBLY

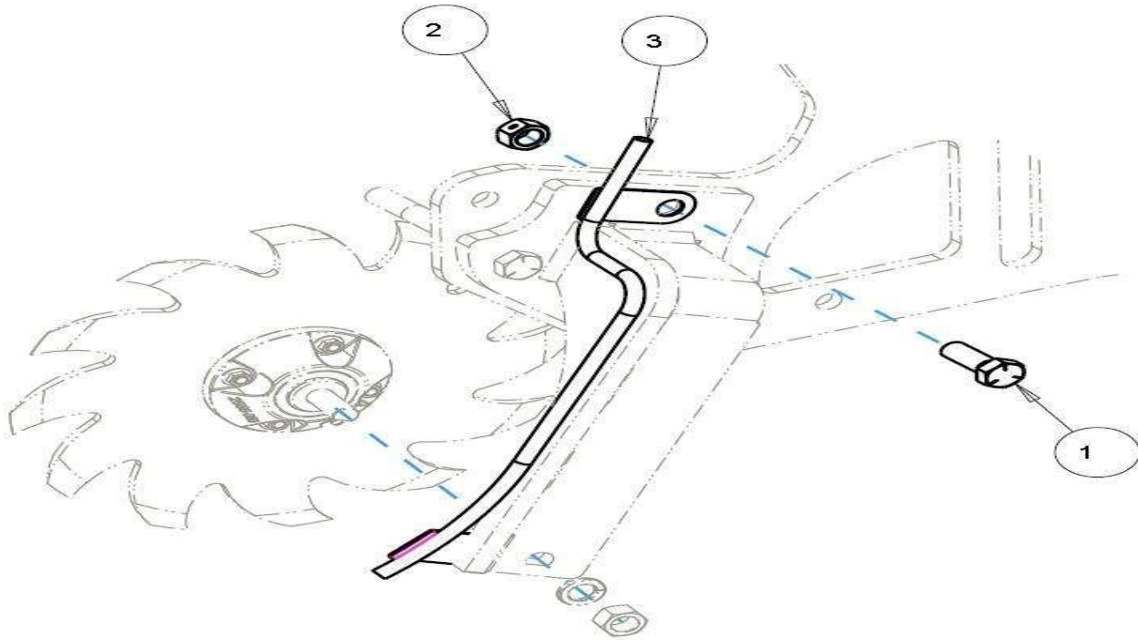

ITEM	PART NO.	DESCRIPTION	QTY
1	2502-331	5/8-11 X 1-3/4 HHCS GR5 ZP	1
2	2520-459	5/8-11 LOCK HEX NUT, GR B, ZP	1
3	2984-254	RH FERTILIZER TUBE W.A.	1

2984-083 - LH LIQUID FERTILIZER KIT ASSEMBLY

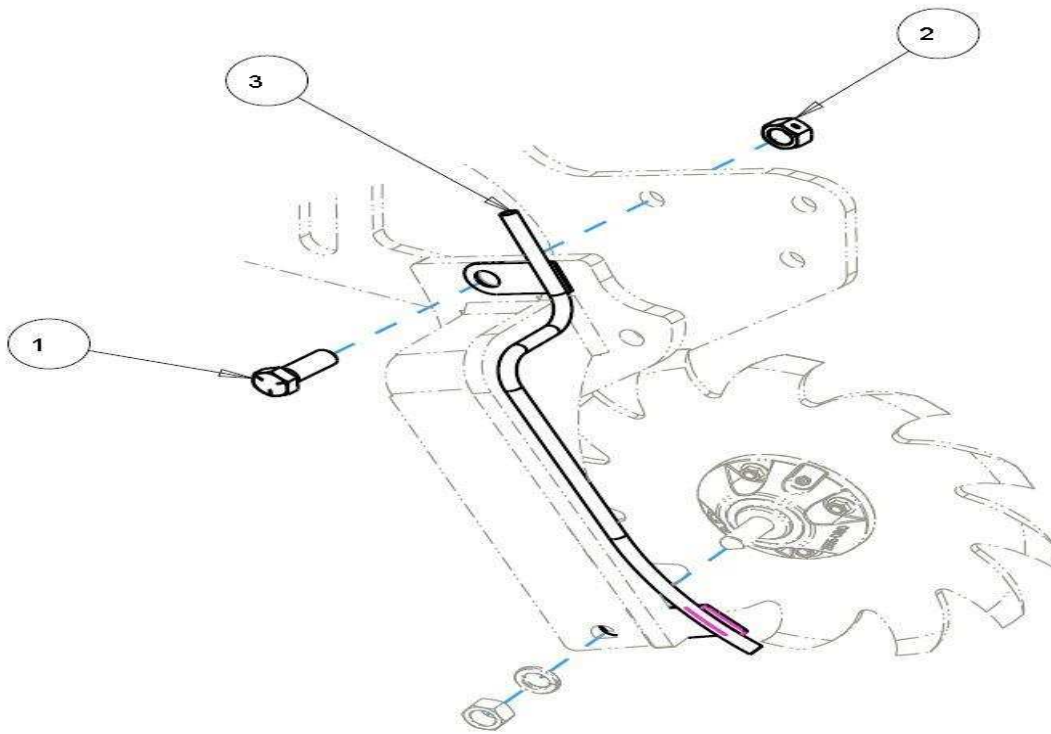

ITEM	PART NO.	DESCRIPTION	QTY
1	2502-331	5/8-11 X 1-3/4 HHCS GR5 ZP	1
2	2520-459	5/8-11 LOCK HEX NUT, GR B, ZP	1
3	2984-253	LH FERTILIZER TUBE W.A.	1

PARTS IDENTIFICATION

2984-084 - CENTER LIQUID FERTILIZER KIT ASSEMBLY

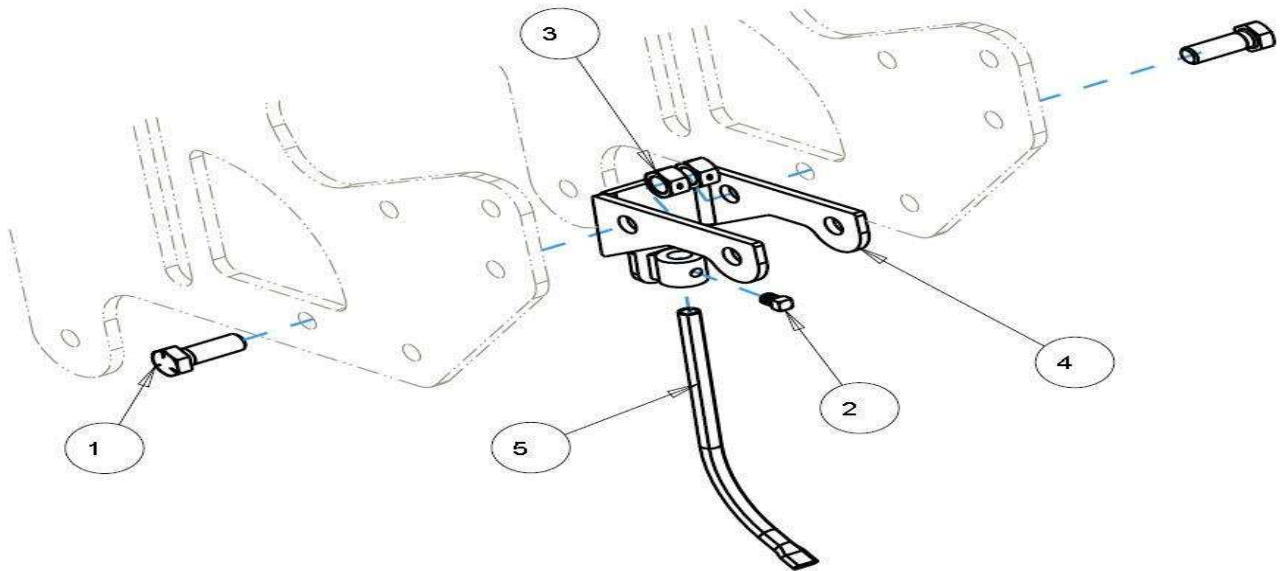

ITEM	PART NO.	DESCRIPTION	QTY
1	2502-331	5/8-11 X 1-3/4 HHCS GR5 ZP	2
2	2503-256	3/8-16X1/2SQHCPSS GR5 STAINLSS	1
3	2520-459	5/8-11 LOCK HEX NUT, GR B, ZP	2
4	2984-252	CENTER FERT MOUNT WA	1
5	2984-446	STRIP FRESHENER LIQ TUBE	1

2984-085 - CENTER DRY FERTILIZER KIT ASSEMBLY

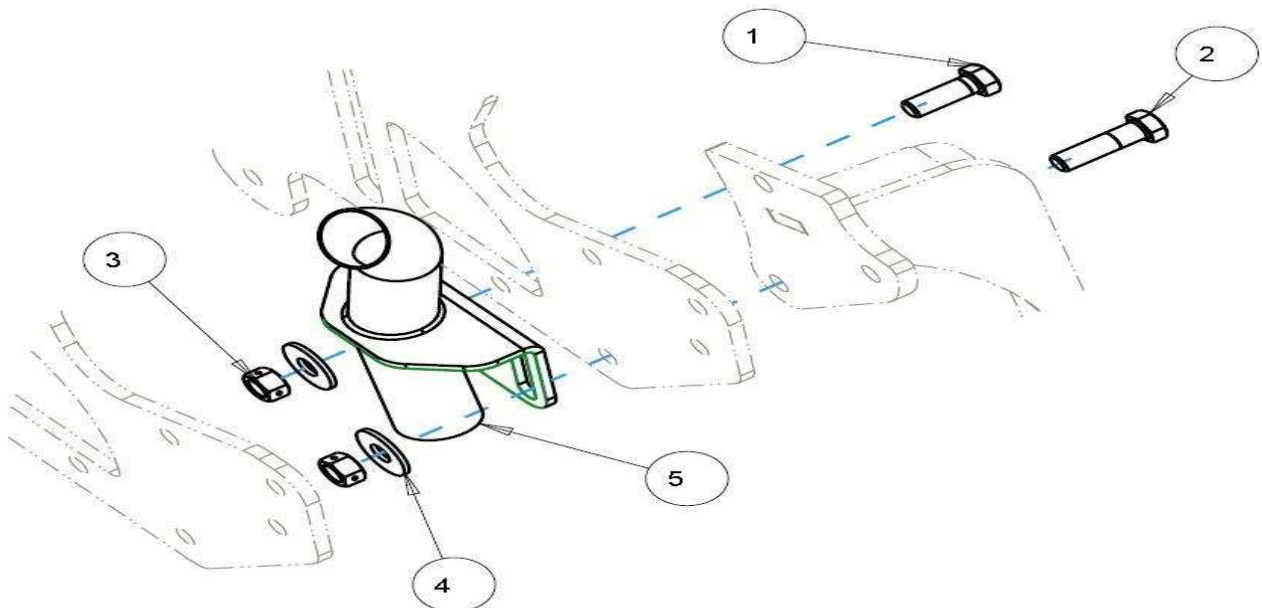

ITEM	PART NO.	DESCRIPTION	QTY
1	2502-331	5/8-11 X 1-3/4 HHCS GR5 ZP	1
2	2502-332	5/8-11 X 2-1/4 HHCS GR5 ZP	1
3	2520-459	5/8-11 LOCK HEX NUT, GR B, ZP	2
4	2526-451	5/8 STD FLATWASHER ZP	2
5	2984-255	CENTER FERT MOUNT WA	1

Troubleshooting Guide

Problem	Cause	Corrective Action
Compressor will not run	<ol style="list-style-type: none"> 1. air system is off 2. hydraulics disengaged 3. no power from battery 4. electrical connection issue 5. shut off psi(145psi) reached 6. worn compressor 7. Improper pressure switch function 	<ol style="list-style-type: none"> 1. Flip switch to ON on cab controller 2. engage compressor hydraulic circuit 3. check power connections from battery, check 2940-150 breaker at the battery 4. check harnesses from cab controller to compressor 5. compressor will restart after tank pressure drops below 125psi 6. replace compressor 7. replace pressure switch
Compressor runs continuously/air flow lower than normal, Compressor Run Time High warning on cab controller if compressor runs continuously for 15 minutes	<ol style="list-style-type: none"> 1. excessive air usage 2. loose connections/air leak 3. Improper pressure switch function 4. clogged air filter element 5. worn compressor 6. defective safety valve 7. tank drain valve open 8. water separator valve leaking 	<ol style="list-style-type: none"> 1. decrease air usage 2. perform leak check on all circuits 3. replace pressure switch 4. clean/replace filter element 5. replace compressor 6. replace safety valve 7. close tank drain valve 8. replace water separator valve
Compressor struggles to build/won't build 145psi	flow control valve adjustment needed	flow control valve adjustment needed
Excessive noise from compressor	<ol style="list-style-type: none"> 1. loose mounting bolts 2. worn bearings 3. cylinder or piston is worn 4. compressor over speeding 	<ol style="list-style-type: none"> 1. tighten bolts 2. replace compressor 3. rebuild compressor 4. check compressor RPMs & slow motor down if needed, hydraulic plumbing of the compressor is incorrect
Excessive moisture in circuits	<ol style="list-style-type: none"> 1. excessive water in air tank 2. high humidity 	<ol style="list-style-type: none"> 1. drain tank, drain tank more frequently 2. move compressor to area with less humidity.
Hydraulic motor front seal leakage	<ol style="list-style-type: none"> 1. case drain clogged or unplugged 2. case drain not plumbed correctly 	<ol style="list-style-type: none"> 1. remove case drain plumbing and clean out debris/obstruction, replace seal 2. Plumb case drain according to the instructions, replace seal
Not able to adjust air in a circuit	<ol style="list-style-type: none"> 1. regulator adjustment knob locked 2. selector valve has activated incorrect circuit 3. defective regulator 	<ol style="list-style-type: none"> 1. unlock regulator adjustment knob (pull) 2. adjust the selector valve to correct circuit 3. replace regulator
Too much residue in the strip	Row cleaner not set properly	<ol style="list-style-type: none"> 1. make row cleaner more aggressive 2. make row cleaner less aggressive (if residue is being thrown on row by adjacent row units)
Strips are not desirable	1. Large clods are left on/in strip	1. decrease row unit depth &/or rolling basket pressure (should decrease wet soil disturbance)

NOTES:





A Tradition of Solutions since 1930

Yetter Farm Equipment Co

PO BOX 358 109 S. McDonough

Colchester, IL 62326-0358

Phone: 309-776-4111

Toll Free: 800-447-5777

Email: info@yetterco.com

For updated models and manuals visit the Yetter website:

www.yetterco.com

© Yetter Farm Equipment Co. All Rights Reserved

2565-968 • 11/2019