



**2984-050E/2984-051B  
CAB CONTROL™  
STRIP FRESHENER™**

OPERATOR MANUAL  
PARTS IDENTIFICATION  
2565-968\_REV\_H • 06/2026



**YETTER MANUFACTURING CO.**  
*FOUNDED 1930*

Colchester, IL 62326-0358

Toll free: 800/447-5777

309/776-3222 (Fax)

Website: [www.yetterco.com](http://www.yetterco.com)

E-mail: [info@yetterco.com](mailto:info@yetterco.com)

**GERMINATE UNIFORMITY™**

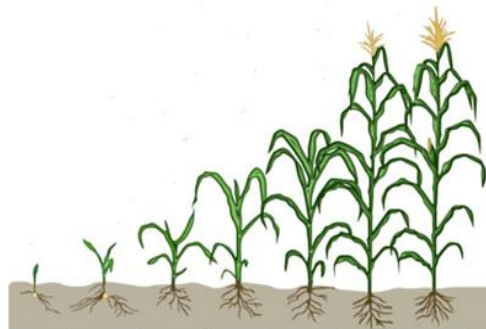

# FOREWORD

You've just joined an exclusive but rapidly growing club.

For our part, we want to welcome you to the group and thank you for buying a Yetter product.

We hope your new Yetter products will help you achieve both goals-increase your productivity and increase your efficiency so that you may generate more profit.

This operator's manual has been designed into four major sections: Foreword, Safety Precautions, Installation Instructions and Parts Breakdown.

This **SAFETY ALERT SYMBOL** indicates important safety messages in the manual. When you see this symbol, be alert to the possibility of **PERSONAL INJURY** and carefully read the message that follows.

 **DANGER:** Indicates an imminently hazardous situation which, if not avoided "will" result in death or serious injury. This signal word is to be limited to the most extreme situations

 **WARNING:** Indicates a potentially hazardous situation which, if not avoided, "could" result in death or serious injury.

 **CAUTION:** Indicates a potentially hazardous situation, which if not avoided, "may" result in minor or moderate injury. It may also be used to alert against unsafe practices.

 **NOTICE:** Indicates information considered important, but not hazard related (e.g., messages relating to property damage).

It is the responsibility of the user to read the operator's manual and comply with the safe and correct operating procedure and to lubricate and maintain the product according to the maintenance schedule in the operator's manual.

The user is responsible for inspecting his machine and for having parts repaired or replaced when continued use of the product would cause damage or excessive wear to the other parts.

It is the user's responsibility to deliver his machine to the Yetter dealer who sold him the product for service or replacement of defective parts, which are covered by the warranty policy.

If you are unable to understand or follow the instructions provided in this publication, consult your local Yetter dealer or contact:

## YETTER MANUFACTURING CO.

309/776-4111

800/447-5777

309/776-3222 (FAX)

Website: [www.yetterco.com](http://www.yetterco.com)

E-mail: [info@yetterco.com](mailto:info@yetterco.com)

## WARRANTY

Yetter Manufacturing warrants all products manufactured and sold by it against defects in material. This warranty being expressly limited to replacement at the factory of such parts or products as shall appear to be defective after inspection. This warranty does not obligate the Company to bear cost of labor in replacement of parts. It is the policy of the Company to make improvements without incurring obligations to add them to any unit already sold. No warranty is made or authorized to be made, other than herein set forth. This warranty is in effect for one year after purchase.

DEALER \_\_\_\_\_

**Yetter Manufacturing warrants its own products only and cannot be responsible for damages to equipment on which mounted.**



## SAFETY PRECAUTIONS



A brief description of signal words that may be used in this manual:

**DANGER**: Indicates an imminently hazardous situation which, if not avoided “will” result in death or serious injury. This signal word is to be limited to the most extreme situations.

**WARNING**: Indicates a potentially hazardous situation which, if not avoided, “could” result in death or serious injury.

**CAUTION**: Indicates a potentially hazardous situation, which if not avoided, “may” result in minor or moderate injury. It may also be used to alert against unsafe practices.

**NOTICE**: Indicates information considered important, but not hazard related (e.g., messages relating to property damage).

Consult your implement and tractor operator's manual for correct and safe operating practices. Be aware of towed implement width and allow safe clearance.

Safety decals are placed on the implement to alert the operator and others to the risk of personal injury or unsafe operation during normal operations and servicing.

1. The safety decals must be kept clean and in good condition to ensure that they are legible.
2. Safety decals must be replaced if they are missing or illegible.
3. When components are replaced during repair or servicing, check that the new components include the necessary safety signs.
4. Replacement safety decals may be obtained from your local dealer.



### WARNING

Read these instructions carefully to acquaint yourself with the Equipment. Working with unfamiliar equipment can lead to accidents.

Never park the equipment on a steep incline or leave the equipment running unattended.

Never clean, lubricate or adjust a machine that is in motion.

Always check that straps are secure.

Make sure latches are in pinned position when moving equipment.

Do not allow children to operate this equipment.

Do not allow riders on the equipment, trailer and/or pick-up.

Use speed and caution dictated by the terrain being traversed. Do not operate on any slope steep enough to cause tipping or loss of control.

Read and understand the operator's manual and require all other persons who will operate the equipment to do the same.

If operating on public roadways, where legal, be certain all lighting is operating properly and observe all traffic laws.

Beware of increased stopping distances and control effort when operating with implements attached.

Be familiar with all controls and be prepared to stop equipment quickly in an emergency.

**FAILURE TO HEED MAY RESULT IN PERSONAL INJURY OR DEATH.**

# 2984-050-R Yetter Strip Freshener

## Features:

- Parallel Linkage/Pneumatic Row Unit Down Force for consistency for all field contours, soil types, & conditions.
- Designed for use with pneumatic row cleaner to enhance strip cleanliness
- Operating speeds between 6-10mph & depth adjustment between 1"-4"
- Two Shark Tooth or Shallow (13) wave wheels run at an angle to churn dirt for optimal seed bed preparation
- Optional liquid or dry fertilizer kits are available for additional value to this field pass
- Heavy Duty, Pneumatic Rolling Basket conditions the strip

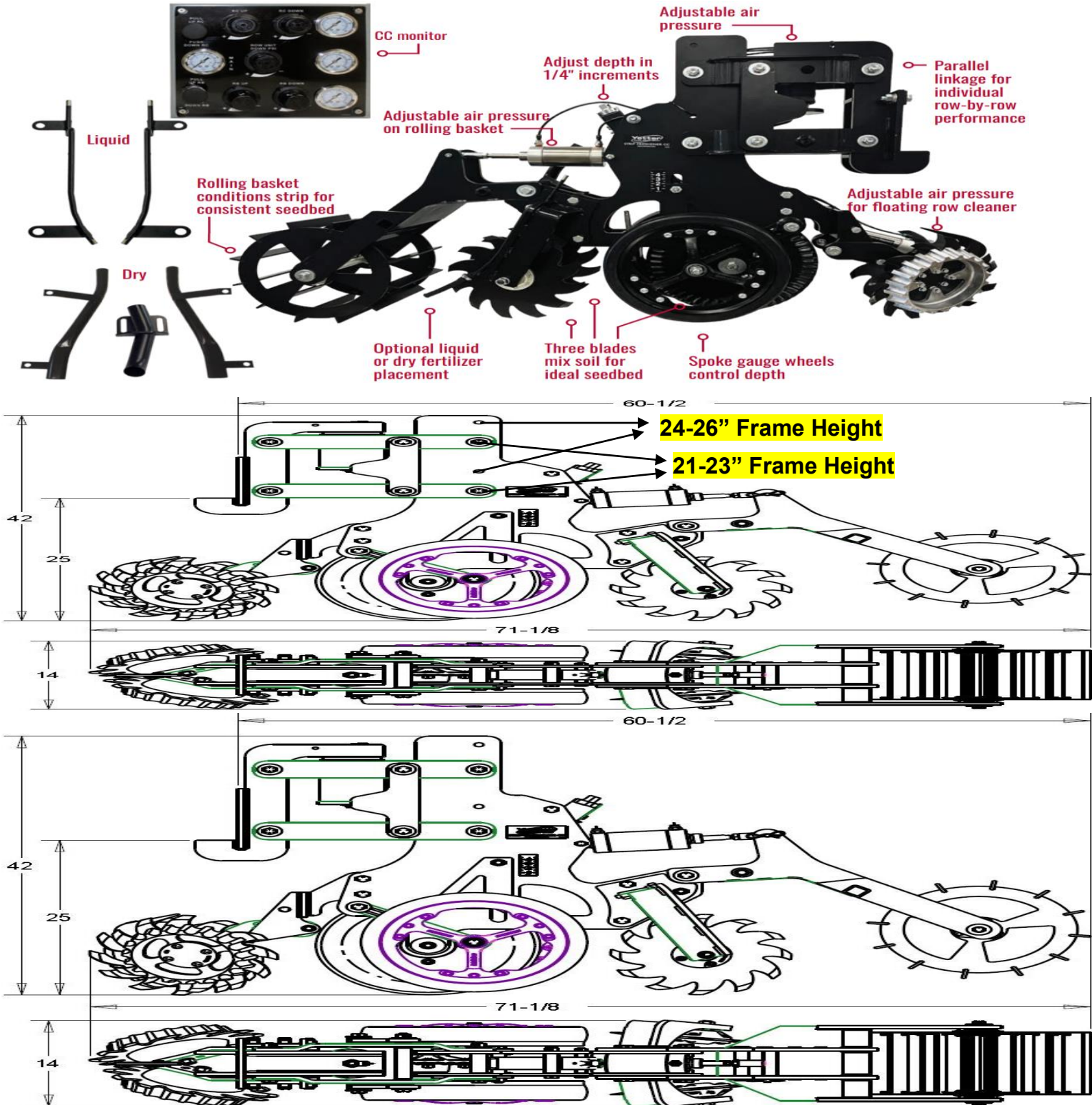

# TABLE OF CONTENTS

FOREWORD/WARRANTY.....	2
SAFETY PRECAUTIONS.....	3
2984 STRIP FRESHENER CC FEATURES/DIMENSIONS .....	4
TABLE OF CONTENTS / BOLT TORQUE.....	5
ASSEMBLY INSTRUCTIONS.....	6 – 15
OPERATION PRECAUTIONS.....	16 – 17
OPERATION.....	17 – 18
MAINTENANCE.....	19 – 20
<b>PARTS IDENTIFICATION</b>	
2984-050/051 STRIP FRESHENER CC ASSEMBLY.....	21
SIDE PLATE / DEPTH ADJUST ASSEMBLY .....	22
PIVOT HARDWARE / PARALLEL LINKAGE ASSEMBLY.....	23
ROW CLEANER MOUNT / NARROW ROW CLEANER ASSEMBLY.....	24
WIDE ROW CLEANER ASSEMBLY.....	25
GAUGE WHEEL ASSEMBLY / BERMING DISC ASSEMBLY .....	26
ROLLING BASKET ASSEMBLY.....	27
WHEEL & HUB/BEARING ASSEMBLY.....	28
SCREW ADJUST ASSEMBLY / 2984-082/083 FERTILIZER TUBE KIT....	29
2984-084 & 2984-085 FERTILIZER KIT.....	30
PNEUMATIC CONTROL BOX.....	31
COMPRESSOR/COMPRESSOR MOUNT KITS.....	32-33
SMALL PARTS / AIRLINE KITS.....	34
<b>TROUBLESHOOTING.....</b>	<b>35</b>

## BOLT TORQUE

Mounting bolts and hardware

All hardware is Grade 5 unless otherwise noted. Grade 5 cap screws are marked with 3 radial lines on the head. If hardware must be replaced, be sure to replace it with hardware of equal size, strength & thread type. Refer to the torque values chart when tightening hardware.







**NOTICE:** Over-tightening hardware can cause just as much damage as under-tightening. Tightening hardware beyond the recommended range can reduce its shock load capacity.

The chart below is a guide for proper torque. Use it unless a specified torque is called out elsewhere in the manual. Torque is the force applied to the end of the handle or cheater bar, times the length of the handle or bar.

**Use a torque wrench wherever possible.**

The following table shows torque in ft.-lbs. for coarse thread hardware.

Bolt Diameter and Threads per Inch	 Grade 2	 Grade 5	 A-325	 Grade 8
1/4	6	10		14
5/16	12	20		30
3/8 – 16	25	35		50
7/16 – 14	35	55		80
1/2 – 13	55	85		125
9/16 – 12	75	125		175
5/8 – 11	105	170		235
3/4-10	185	305		425
7/8 – 9	170	445		690
1-8	260	670		1030
1 1/8 – 7	365	900		1460
1 1/4 - 7	515	1275		2060
1 3/8 – 6	675	1675		2700
1 1/2 - 6	900	2150		3500
1 3/4 – 5	1410	3500		5600

**CHECK HARDWARE DAILY FOR DAMAGE, WEAR, & LOOSENESS. TIGHTEN AS NEEDED**

# Assembly Instructions

**TOOLS NEEDED:** ½" Drive Impact, ½" Drive Torque Wrench, ¼" Drive Socket & Ratchet Set, Funnel for adding oil in Yetter Hyd. Compressor, Air Tubing Cutters, Side Cutters, Pliers, Standard Wrenches, Standard Sockets, Tape Measure, Marker

**Prepping Toolbar** – Using a Marker, mark center of toolbar. Once center is marked, measure off of that mark half the distance of what row spacing of each unit will be. For example, if you're setting up toolbar for 30" row spacing, measure off of your center mark 15" on each side & make a mark. A 30" layout is pictured below for reference. If you are setting toolbar up on 20" row spacing, measure 10" on each side of center mark & make a mark. Mark the center of mounting plate on each strip freshener.

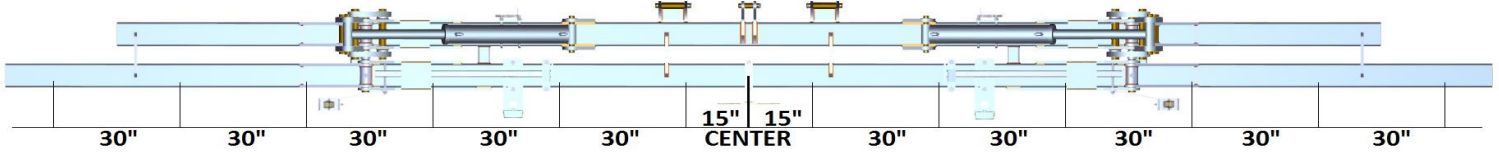

**Installing units** – Align marks on toolbars where each strip freshener is to be installed with marks on mounting plate on strip freshener. Use hardware to mount each unit. If clearance issues with weldments/hinge points on toolbar arise, alternate parts may be required. Fold toolbar when all units installed to check for any clearance issues.

**OFFSET MOUNTING BRACKET OPTIONS ARE AVAILABLE, CALL YETTER SERVICE, 1-800-447-5777**

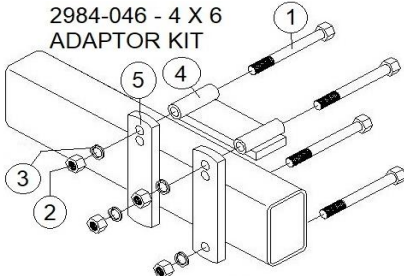

ITEM	PART #	DESCRIPTION	QTY
1	2502-509	¾-10 X 7 HHCS GR 5	4
2	2520-504	¾-10 HEX NUT	4
3	2525-501	¾ LOCKWASHER	4
4	2986-224	ADAPTER	1
5	2986-306	STRAP	2

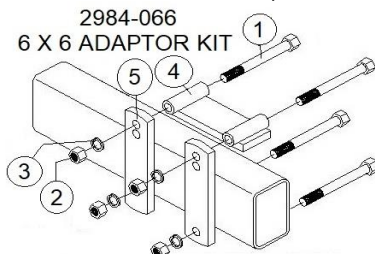

ITEM	PART #	DESCRIPTION	QTY
1	2502-514	¾-10 X 9 HHCS GR 5	4
2	2520-504	¾-10 HEX NUT	4
3	2525-501	¾ LOCKWASHER	4
4	2986-224	ADAPTER	1
5	2986-306	STRAP	2

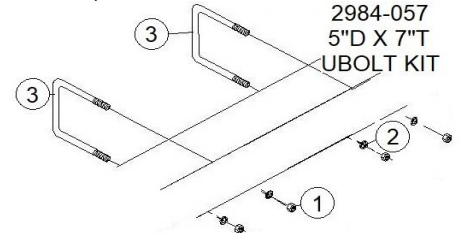

ITEM	PART #	DESCRIPTION	QTY
1	2520-504	¾-10 HEX NUT	4
2	2525-501	¾ LOCKWASHER	4
3	2570-477	¾" X 7 X 7 U-BOLT	2

ITEM	PART #	DESCRIPTION	QTY
1	2520-504	¾-10 HEX NUT	4
2	2525-501	¾ LOCKWASHER	4
3	2570-478	¾" X 7 X 9 U-BOLT	2

2984-077  
7" D X 7" T  
UBOLT KIT

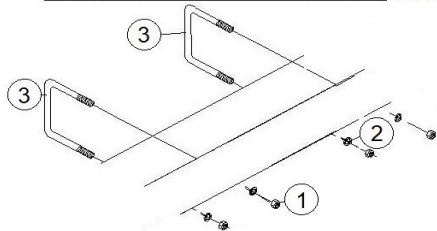

ITEM	PART #	DESCRIPTION	QTY
1	2520-504	¾-10 HEX NUT	4
2	2525-501	¾ LOCKWASHER	4
3	2570-644	¾" X 9 X 9 U-BOLT	2

2984-079  
7" D X 9" T  
UBOLT KIT



3800-115  
7" OFFSET  
4.5" SETBACK  
KIT

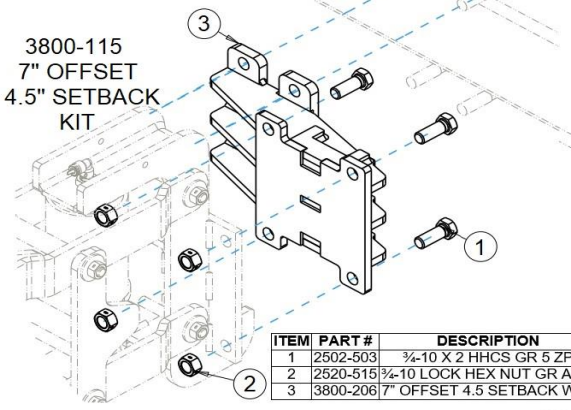

ITEM	PART #	DESCRIPTION	QTY
1	2502-503	¾-10 X 2 HHCS GR 5 ZP	4
2	2520-515	¾-10 LOCK HEX NUT GR A ZP	4
3	3800-206	7" OFFSET 4.5 SETBACK W.A.	2

3000-131 EXTENSION  
MOUNT KIT  
(USED AT HINGE BRACES  
ON TOOLBARS)

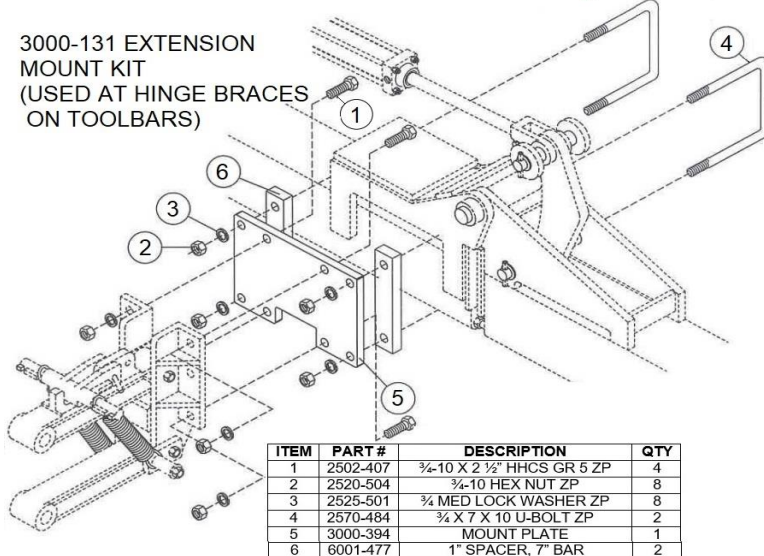

ITEM	PART #	DESCRIPTION	QTY
1	2502-407	¾-10 X 2 ½" HHCS GR 5 ZP	4
2	2520-504	¾-10 HEX NUT ZP	8
3	2525-501	¾ MED LOCK WASHER ZP	8
4	2570-484	¾ X 7 X 10 U-BOLT ZP	2
5	3000-394	MOUNT PLATE	1
6	6001-477	1" SPACER, 7" BAR	2

3831-050  
4" OFFSET  
SETBACK KIT  
FOR 2984

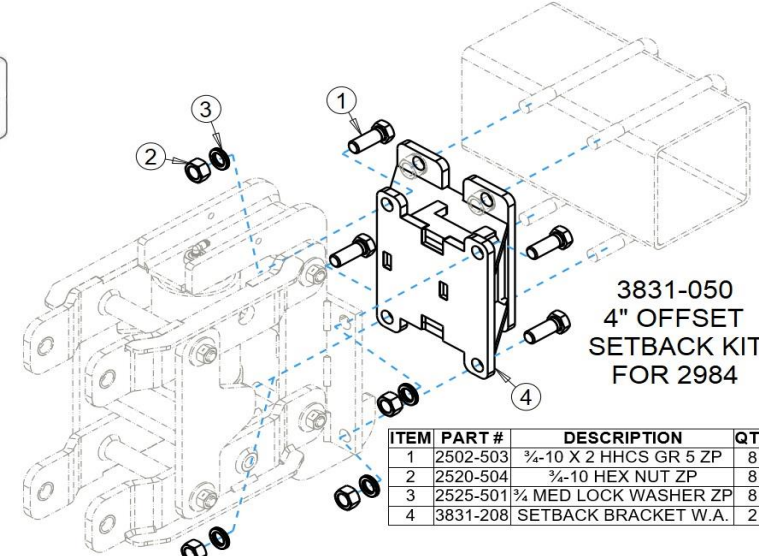

ITEM	PART #	DESCRIPTION	QTY
1	2502-503	¾-10 X 2 HHCS GR 5 ZP	8
2	2520-504	¾-10 HEX NUT ZP	8
3	2525-501	¾ MED LOCK WASHER ZP	8
4	3831-208	SETBACK BRACKET W.A.	2

# Assembly Instructions

## Row Cleaner Assembly

Assemble pivot arm to row cleaner mount on strip freshener CC unit. Narrow arms go on inside of row cleaner mount plates & wide arms go on outside of row cleaner mount plate. Place a 9/16 pivot bushing inside the split tension bushing in rear hole on each side of pivot arm, align hole on each arm with rear hole on each side of row cleaner mount, slide a 5/8 flat washer over each 5/8" X 2" bolt, install each bolt through the arm/mount plate, & fasten with a 5/8" lock nut. Install down/up stop components using a 1/2" X 1 3/4" bolt through remaining 2 holes on each side of row cleaner mount plate, slide a 9/16" spacer over each bolt, & fasten in place with a 1/2" lock nut. Assemble air cylinder to row cleaner; place clevis on rod end of cylinder over hole on pivot arm handle & install shorter pin & 1/8" cotter pin. Install cap end of cylinder between mount tabs on row cleaner faceplate & install longer pin & 1/8" cotter pin. Install wheel assemblies by sliding D-bolt in D-hole on pivot arms, & fasten wheel assembly to pivot arm using a 5/8" lock washer & 5/8" nut, torque to 190ft/lbs. **REMOVE PLASTIC GUARDS FROM WHEEL ASSEMBLIES!!!**  
**Install row cleaner wheels in back set of holes on pivot arm.**

## NARROW ROW ASSEMBLY

## WIDE ROW ASSEMBLY

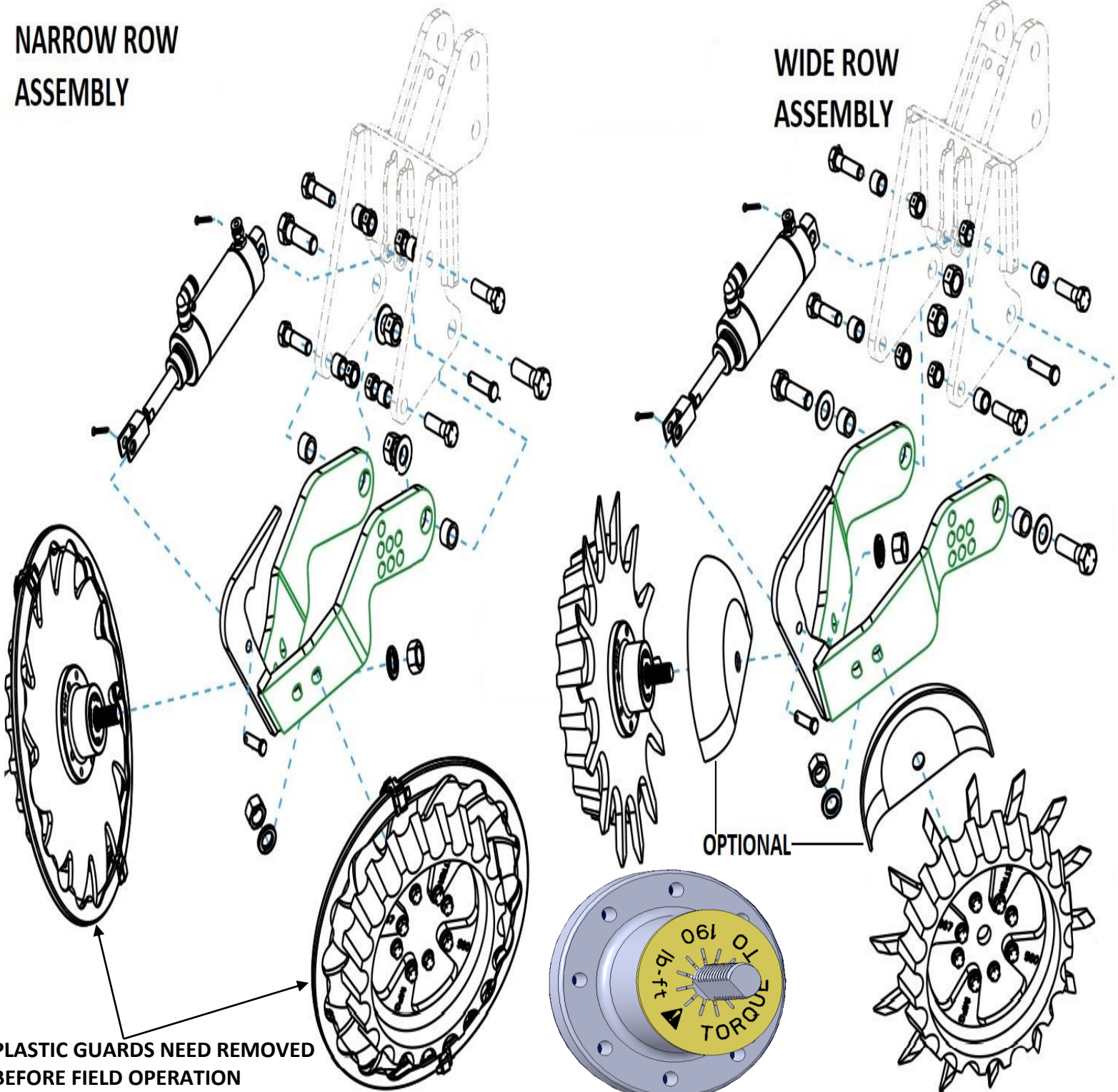

PLASTIC GUARDS NEED REMOVED BEFORE FIELD OPERATION

Torque to 190ft/lbs

# Assembly Instructions

## Hydraulic Compressor Assembly (if ordered)

**Prepping** – The crate labeled 2940-055 should include the Yetter hydraulic compressor, 1 liter bottle of oil, 2940-181 hyd. comp. solenoid/pressure switch “Y” harness, & 2940-189 10’ hyd. communication harness. The 2940-181 & 2940-189 can be discarded. Remove compressor from crate. Remove housing by removing 6 bolts (4 are pictured in picture 1 below, the other 2 are on opposite side of the housing) using a ratchet with 7/16 socket & a 7/16 wrench. Remove the dipstick & slowly fill pump with provided oil until oil reaches the fill line on the sight glass. Fill pump slowly as there is a significant delay between oil entering pump & seeing oil on the sight glass. Confirm the oil level is full on the dipstick as well. Reinstall the dipstick, housing, & control block. Remove the wing nut on the air filter housing, remove the air filter cover, & inspect the condition of the air filter. Reinstall the filter, cover, & wing nut making sure the filter is sealed between the filter base plate & cover.

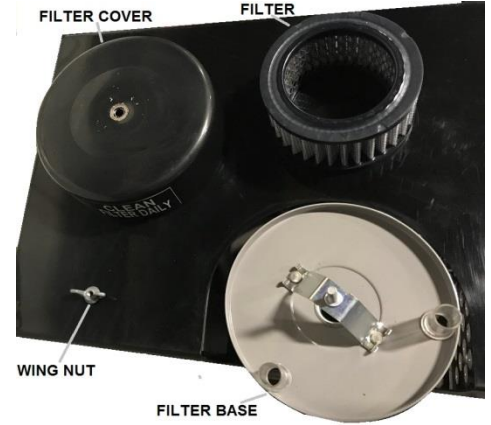
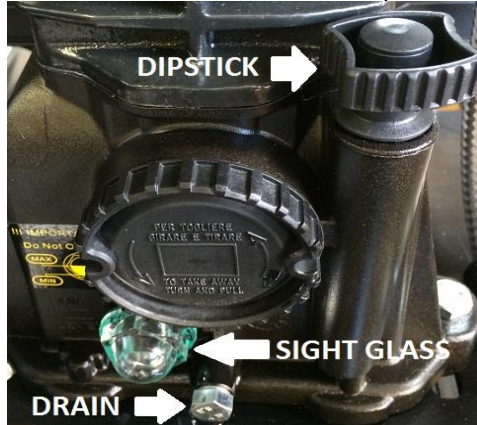
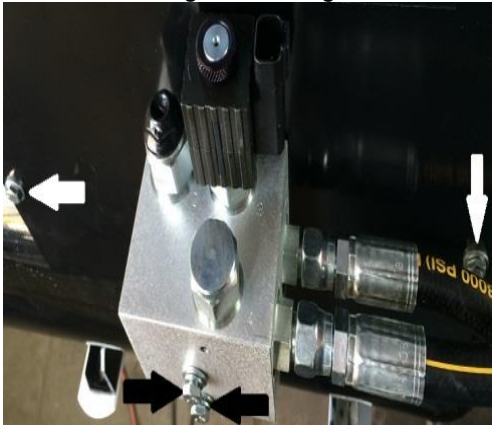

**Mounting** – Each strip till machine will have its own unique mounting location. Select an area to mount the compressor that is centrally located near hitch of tractor. **YOU SHOULD EXERCISE YOUR OWN BEST JUDGEMENT TO FIT YOUR SITUATION.** Use mounts supplied or depending on application different mounts may need to be built or Yetter mounts may need modified. Be sure to check clearance in all locations, especially noting tractor tires, folding/unfolding toolbar for transport mode, marker arms, & fertilizer tanks. The 2940-086 universal mount kit is most commonly used mount for this application, longer bolts may be needed.

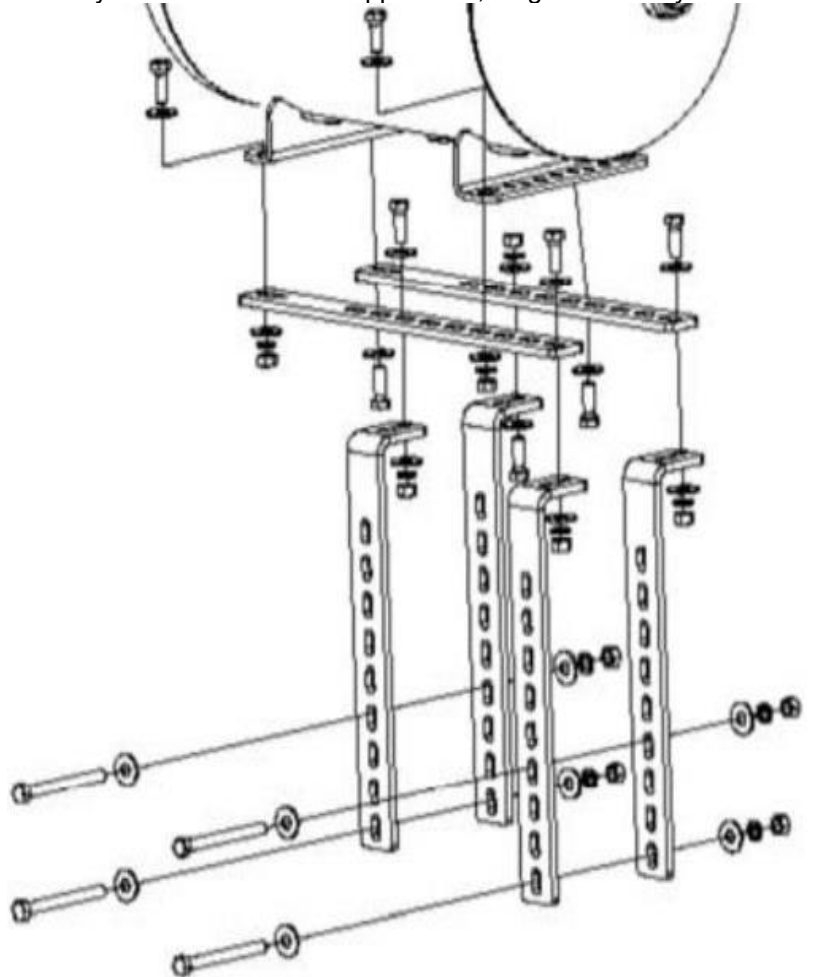

# Assembly Instructions

## Hydraulic Compressor Assembly (if ordered)

### Plumbing

- A) Attach the hydraulic pressure gauge to the port on the hydraulic block labeled GP (may already be assembled).
- B) Remove the cap from the - 6 port (also labeled P on the Hydraulic Control Block) & install the 2515-431 - 6 ORB (O-Ring Boss) to - 6 JIC straight adaptor fitting so that the O-Ring end goes into the hydraulic block & the JIC end faces away from the block. Install 1) 2515-831 3/8 - 6 10ft hydraulic hose to that fitting.
- C) Remove the cap from the - 8 port (also labeled T on the Hydraulic Control Block) & install the 2515-833 - 8 ORB to - 8 JIC straight adaptor fitting so that the O-Ring end goes into the hydraulic block & the JIC end faces away from the block. Install the 2515-832 1/2 - 8 10ft hydraulic hose to that fitting.

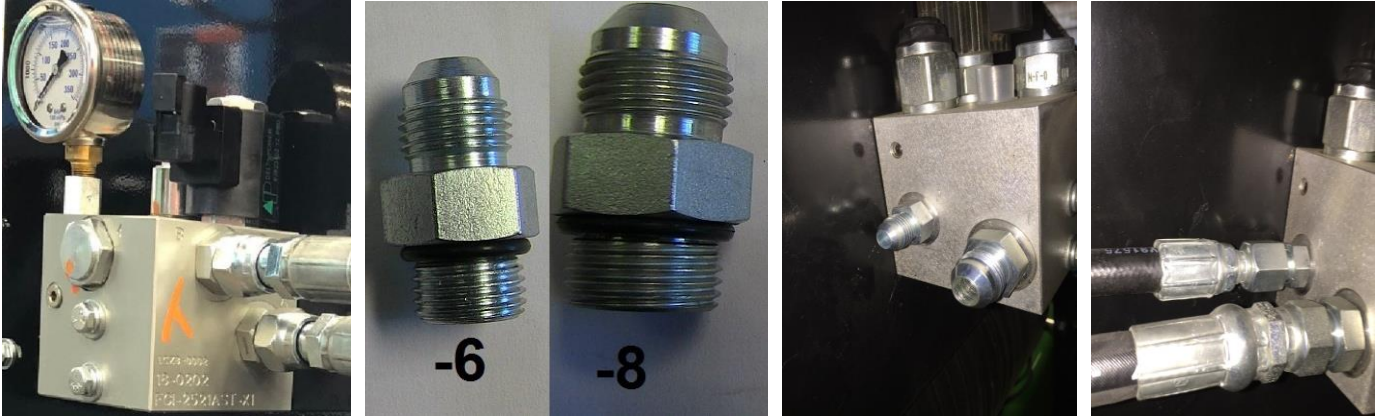

- C) Remove the cap plug from the - 4 port on the motor using a 3/16 hex key wrench or screwdriver if this has a rubber plug (this is the Case Drain port) & install the 2515-848 -4 ORB to - 6 JIC 90 degree adaptor fitting so that the O-Ring end goes into the hydraulic motor & the JIC end faces downward. Install 1) 2515-831 3/8 - 6 10ft hydraulic hose to that fitting.

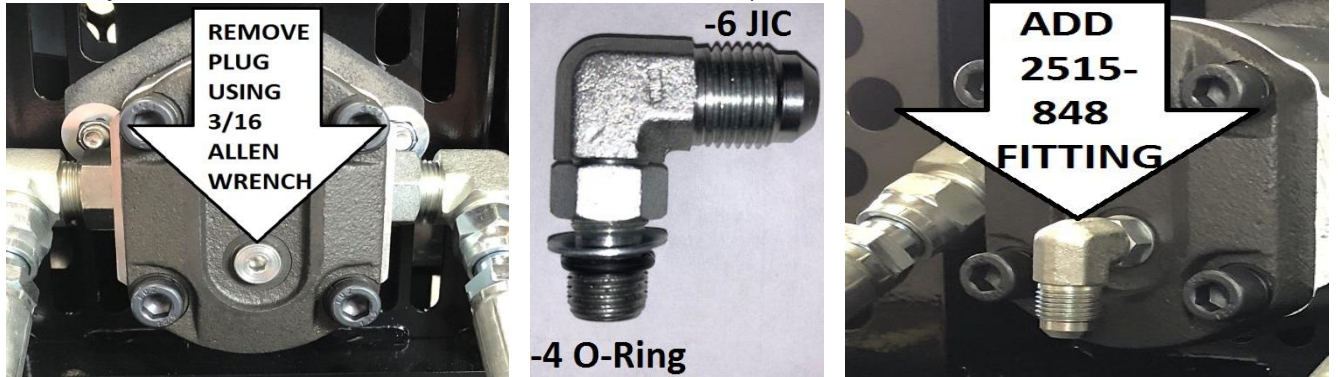

Attach 1 pioneer coupler to the 1/2" hydraulic hose for the compressors return using -8JIC - -8ORB adaptor. Attach 1 pioneer coupler to the 3/8" hydraulic hose for the compressor pressure using -6JIC - -8ORB adaptor. Connect the hydraulic hose attached to case drain on the motor to the case drain connector on the tractor. Case drain coupler not provided. The Yetter hyd. compressor is equipped with a case drain port on the motor. Case Drain is a pressure free circuit that provides a flow path to the reservoir for hydraulic fluid used to cool & lubricate the motor. Make sure to connect case drain to reservoir where the hydraulic flow to the compressor is received. If tractor isn't equipped with case drain, a kit may be purchased from the tractor OEM dealer.

### PIONEER COUPLER



### CASE DRAIN FLAT FACE COUPLERS



### CONNECTED AT TRACTOR DRAIN



# Assembly Instructions

## Electric Compressor Assembly (if ordered)

**Mounting** – Each strip till machine will have its own unique mounting location. Select an area to mount the compressor that is centrally located near hitch of tractor. **YOU SHOULD EXERCISE YOUR OWN BEST JUDGEMENT TO FIT YOUR SITUATION.** Use mounts supplied or depending on application different mounts may need to be built or Yetter mounts may need modified. Be sure to check clearance in all locations, especially noting tractor tires, folding/unfolding toolbar for transport mode, marker arms, & fertilizer tanks. The 2940-086 universal mount kit will be most commonly used mount for this application.

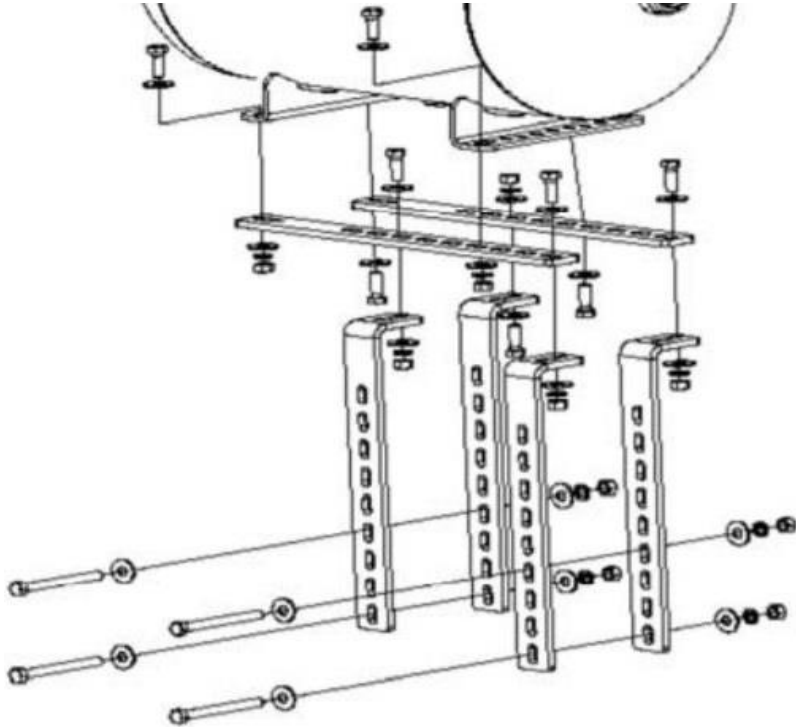

**Power Cable Installation** - : Install the 2940-150 main power cable with 80A breaker on the operating tractor's battery. Red cable installs on the positive (+) battery terminal post and the black cable installs on the negative (-) battery terminal post. From the open 2 pole Anderson connector of the 2940-150, safely route & install the appropriate length of main power extension cables, 2940-151 is a 10ft main power extension & 2940-163 is a 20ft main power extension, into the Anderson connector that comes out of the bottom of the compressor housing. If operating tractor is articulating or if compressor is further back on the planter than the hitch, more extension cables may be needed. **Cable length from the battery to the compressor should not exceed 50 feet. Longer than 50 feet distances cause the 80A breaker to become weak and trip often. If distance is greater than 50 feet, heavier cable needs made using 00 gauge wire.**



# Assembly Instructions

## Mount the Control Box

Attach the 2984-512 Ram ball base to the tractor's monitor mounting device. Some tractors have round tube & some have slotted flat steel. Pick a location near the right rear corner post so that adjustments can be made easily while viewing the strip freshener units' performance. Attach the 2984-513 double socket arm to the tractor mounted ball & the control box mounted ball & tighten the T-knob to fix the control box into place.



## Plumbing the Control Box – Mounting the 2515-907 Coupler

Route the 2984-162 Cab Airline Bundle from the toolbar to the control box inside the tractor cab. Install each color airline into the port # that matches the circuit described below. Install the 2515-907 6 port airline coupler at the hitch of the tractor (mounting hardware not included), cut each color airline of the 2984-162 at the coupler & install the airline into each side of the coupler as shown in the diagram below. At the end of the 2984-162 that is at the toolbar, cut each color (except RED) of airline to length & tee each color into its corresponding circuit once the trunk airline is plumbed for each circuit. If the remaining length of airline from the 2984-162 isn't long enough to reach from the hitch to the toolbar, use airline out of the 100ft rolls & use the remainder of the 2984-162 somewhere else.

- 1 – Compressor Supply **RED**
- 2 – Row Cleaner Down **BLACK**
- 3 – Row Cleaner Up **BLUE**
- 4 – Row Unit Down Force **ORANGE**
- 5 – Rolling Basket Down **GREEN**
- 6 – Rolling Basket Up **YELLOW**

1	COMP	<b>RED</b>	COMP
2	RC DN	<b>BLACK</b>	RC DN
3	RC UP	<b>BLUE</b>	RC UP
4	DF	<b>ORANGE</b>	DF
5	RB DN	<b>GREEN</b>	RB DN
6	RB UP	<b>YELLOW</b>	RB UP

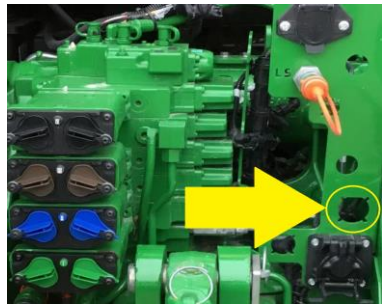
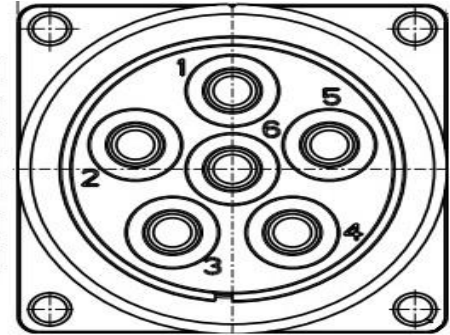

1	COMPRESSOR SUPPLY
2	ROW CLEANER DOWN
3	ROW CLEANER UP
4	ROW UNIT DOWN FORCE
5	ROLLING BASKET DOWN
6	ROLLING BASKET UP



2515-907 6 PORT COUPLER

## Plumbing the Compressor

Install the 1200-353 3/8 Stem to 1/4PC reducer into the outlet 3/8" outlet elbow on the compressor. Install the 1/4" **RED** airline from the 2984-162 Cab Airline Bundle into the 1/4"PC.



# Assembly Instructions

## Switched Power – Electric or Hydraulic Compressors

Attach the male 2 pin connector of the 2940-153 to the female 2 pin connector on the 2984-156 Cab Controller that is closest to the front side. Install the connector not provided for your tractor at the bare end of the 2940-153 and connect to tractors switched power source. Connect the black wire on the Yetter harness to the black wire of the switched power harness. Connect the red wire on the Yetter harness to the orange wire on the switched power harness. Connecting the red wire on the Yetter harness to the red wire on the switched power harness will provide constant power to the switch on the Yetter control box and may lead to draining the tractor's battery.

At the compressor, install the compressor control harness; 1) male 2 pin connector plugs into the compressors solenoid, & 1) 2 pin female connector plugs into pressure switch.

Install 1) 2940-154 30' extension from the connector near the back side of the cab controller to the hitch of the tractor. Install as many of the 2940-154 30' Extensions as necessary to connect the Y harness at the compressor to the 2 pin connector at the hitch of the tractor.

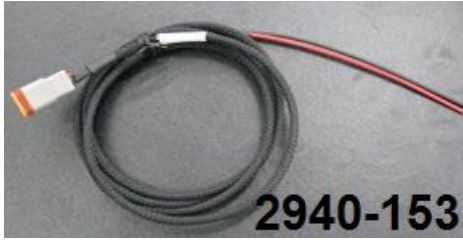

Switched Power Source  
Connector part #'s:

**JD PART #: RE67013**

**CNH PART #: 187103A1**

**CAT P/N: AG233356**

----->

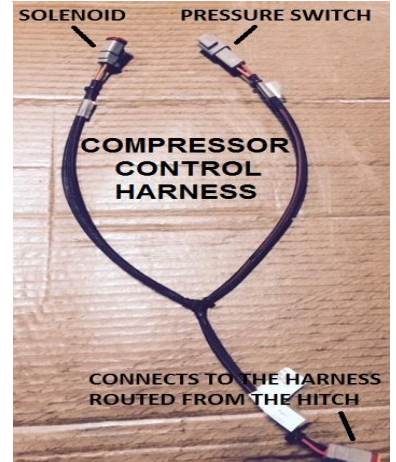
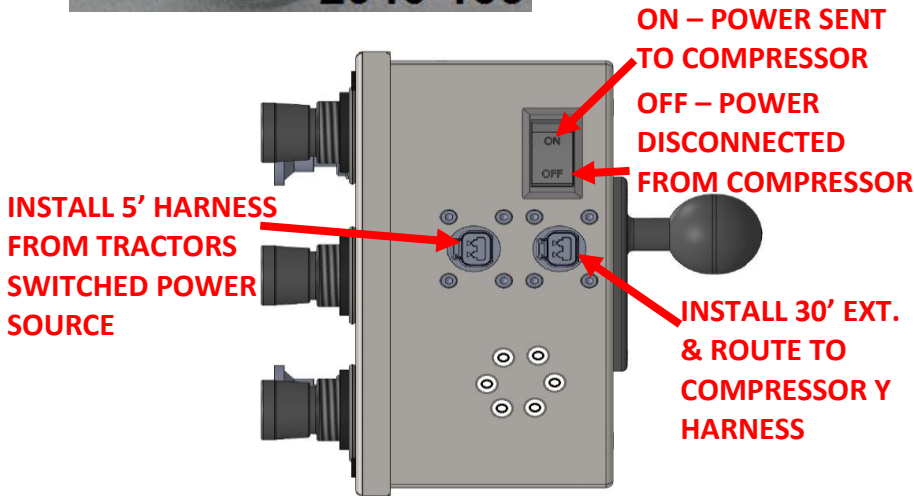

### HYDRAULIC COMPRESSOR

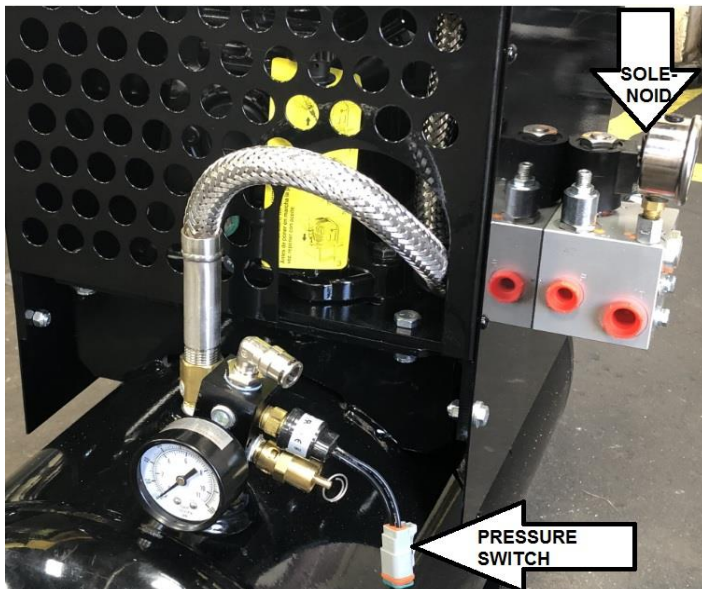

### ELECTRIC COMPRESSOR

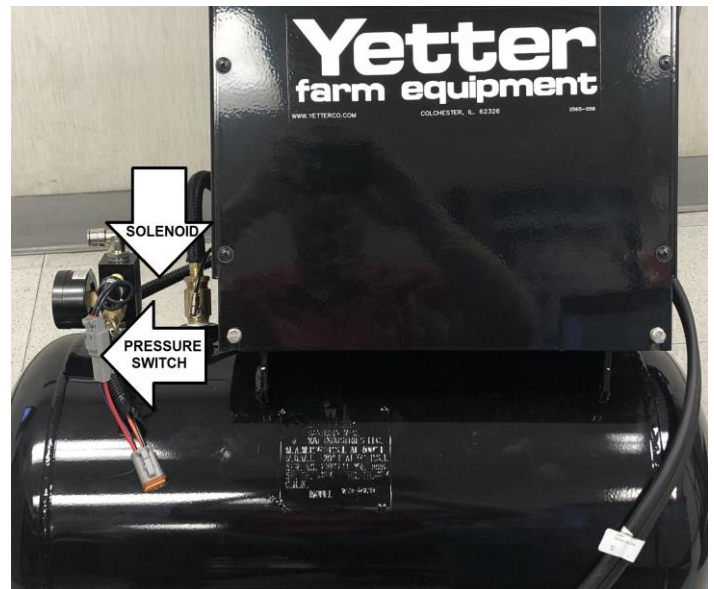

# Assembly Instructions

## Plumbing Each Strip Freshener – Row Unit Bundle

**Row Cleaner Down** – Use 1/4" **BLACK** plumb this circuit **Row Cleaner Up** – Use 1/4" **BLUE** airline to plumb this circuit **Row Unit Down Force** – Use 1/4" **ORANGE** airline to plumb this circuit **Rolling Basket Down** – Use 1/4" **GREEN** airline to plumb this circuit **Rolling Basket Up** – Use 1/4" **YELLOW** airline to plumb this circuit

**Step 1:** Install 2984-161 Row Unit Bundle W/ Tee Bank at each row unit. Use zip ties to keep airlines away from wear/pinch points on each row

1/4" TEE

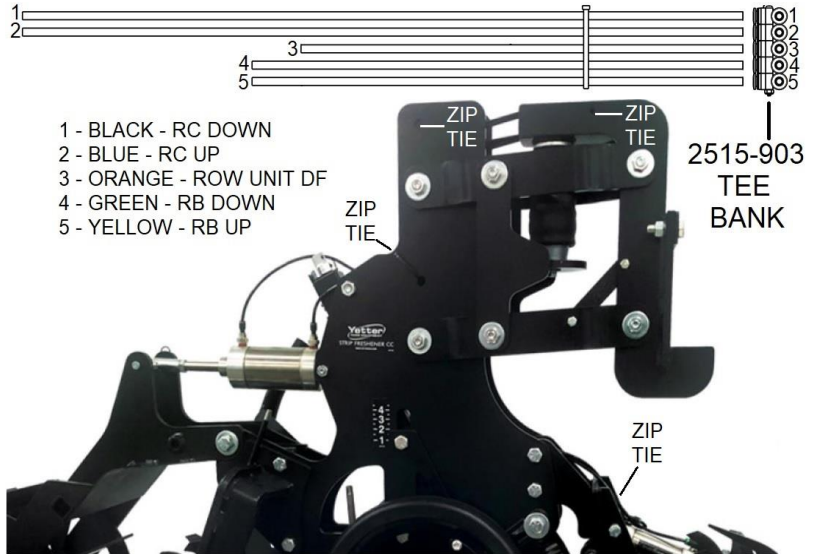
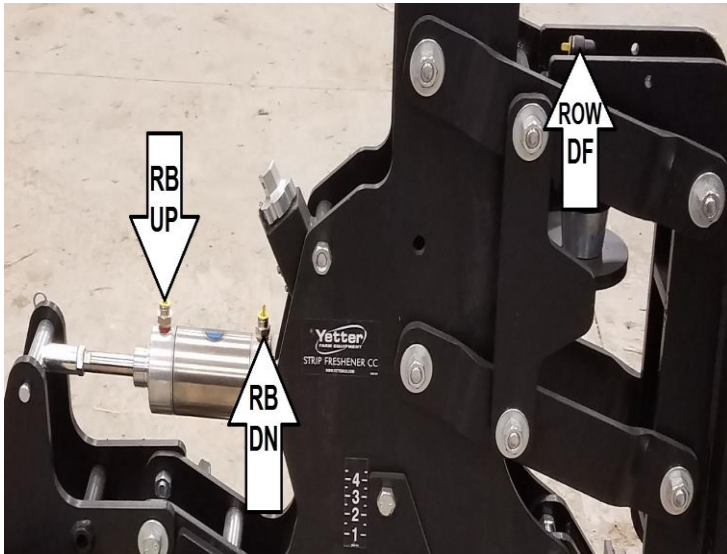
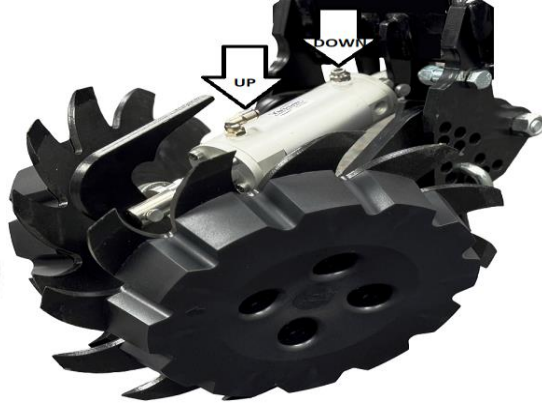

ROW CLEANER

ROLLING BASKET

BACKSIDE TO TOOLBAR

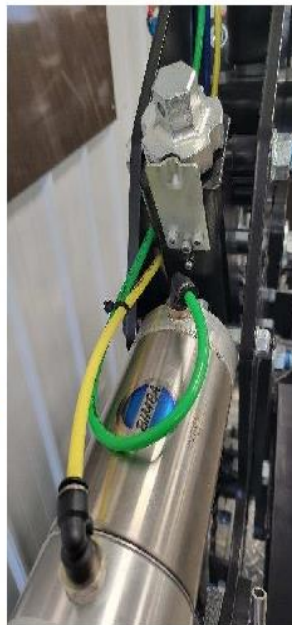

# Assembly Instructions

## Plumbing Strip Freshener Trunk Airlines

### General Plumbing Instructions

Smaller, rigid toolbars will have 1 trunk airline from 1<sup>st</sup> row to last row for each circuit. Folding toolbars will have 3 trunk airline groups for each circuit; left wing, center frame, & right wing. See diagrams below for rigid (8 row shown) & folding (16 row shown) as a template for your application. Trunk airlines should be routed on top side of toolbar keeping airline away from wear points & pinch points. Each end of airline should be cut flush. Make sure to leave plenty of slack at hinges for folding/unfolding & for when toolbar flexes. On front fold toolbars, route the airline from the 6 port hitch coupler down 1 or both draft tubes to feed trunk airlines.

**Rigid Toolbar** – After each row unit airline bundle & tee bank are installed on each row, use the 100' rolls of each color of airline to install airline between each row & make sure to keep the airline color coordinated for each circuit. At each end row's tee bank, use 2515-904 1/4" plugs to cap off the end of the tee bank. If you do not want to use the plugs, you could remove the row unit airline bundle & tee bank from each outside row & use the 100ft rolls to connect row 1 to row 2s tee bank & the last row to the next to last rows tee bank. When the trunk airline is complete, install a tee bank centrally located on the toolbar, install the 2984-162 Cab Airline Bundle from page 11 into this tee bank to complete the installation of the supply airline into the trunk airline.

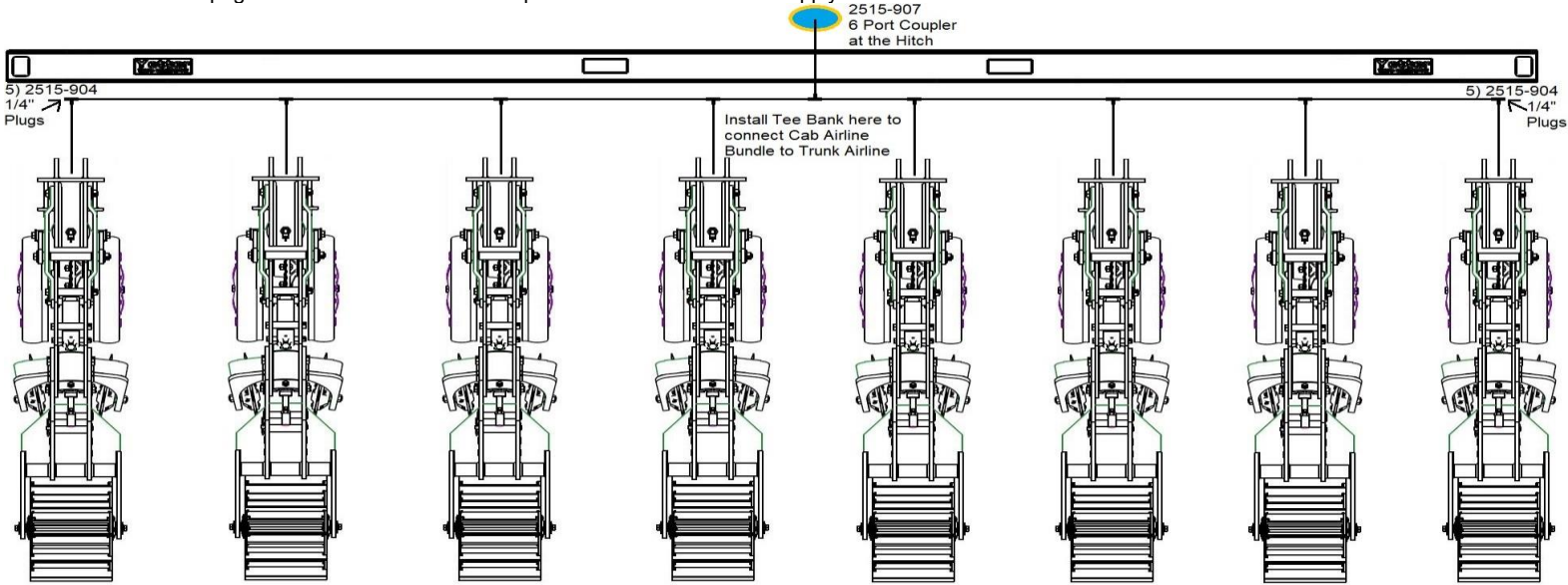

**Folding Toolbar** – After each row unit airline bundle/tee bank are installed on each row, use 100' rolls of each color of airline to install airline between each row, keep airline color coordinated for each circuit. Narrow transport toolbars may only have 4 rows on center section so number of rows for each sections' trunk airline will vary. Plumb airline between each row on left wing, then center section, & then right wing. Use 5) 2515-904 1/4" Plugs to cap off the tee bank on 1<sup>st</sup> & last row of each section. At center of each sections' trunk airline, cut each color of airline & install a Tee Bank. Install each color of airline from Tee Bank on left wing & right wing to the center of toolbar. Use a Tee Bank to connect airlines from each wing by circuit, & then install each color of airline from the remaining port of this Tee Bank to Tee Bank on center section. Install another Tee Bank next to Tee Bank that connects all 3 sections together & install each color airline between this Tee Bank & 2515-907 6 Port Coupler at Hitch. This should complete plumbing installation as 2984-156 Cab Controller should be supplying air to each circuit on each section of toolbar.

- 1 - Red - Compressor Supply
- 2 - Black - RC Down
- 3 - Blue - RC Up
- 4 - Orange - Row Unit DF
- 5 - Green - RB Down
- 6 - Yellow - RB Up

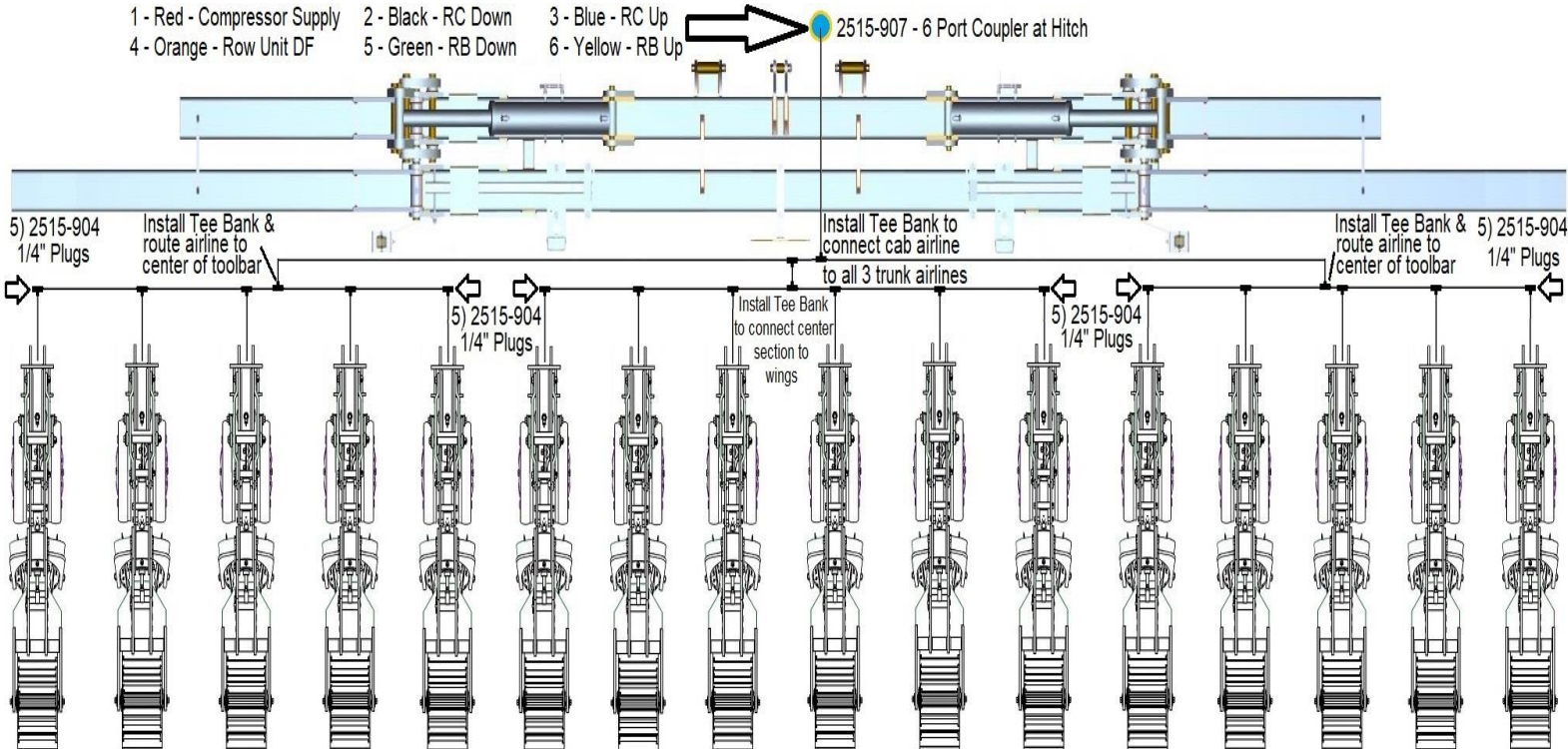

# Assembly Instructions

## Installation of the Fertilizer Tubes (If Applicable)

Below are assembly diagrams for the 4 fertilizer tube kits offered for the 2984 Strip Freshener CC units. An additional clamp on hose is offered for each of the liquid kits to get the fertilizer closer to the soil profile to help keep the fertilizer in the desired location & keep splatter to a minimum. When installing the fertilizer delivery hoses, follow the same route as the airlines. Follow the OEM installation instructions on flow rate, orifices, etc.

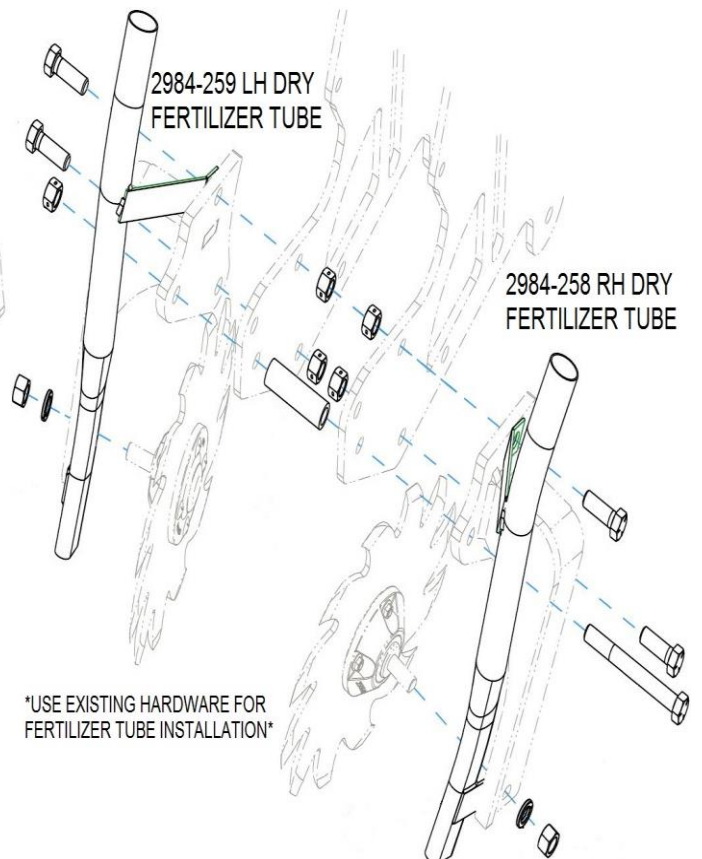
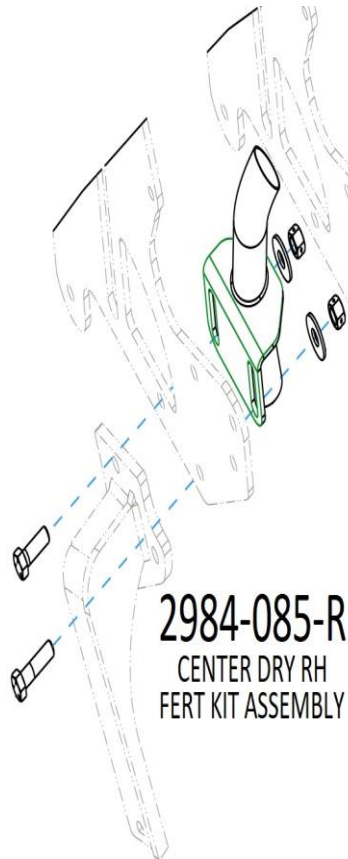
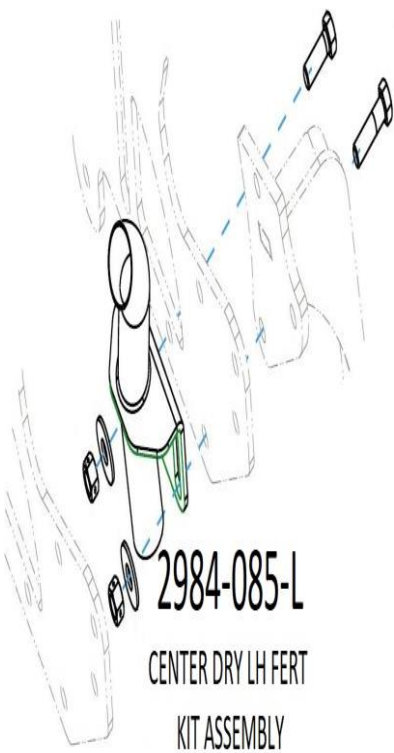
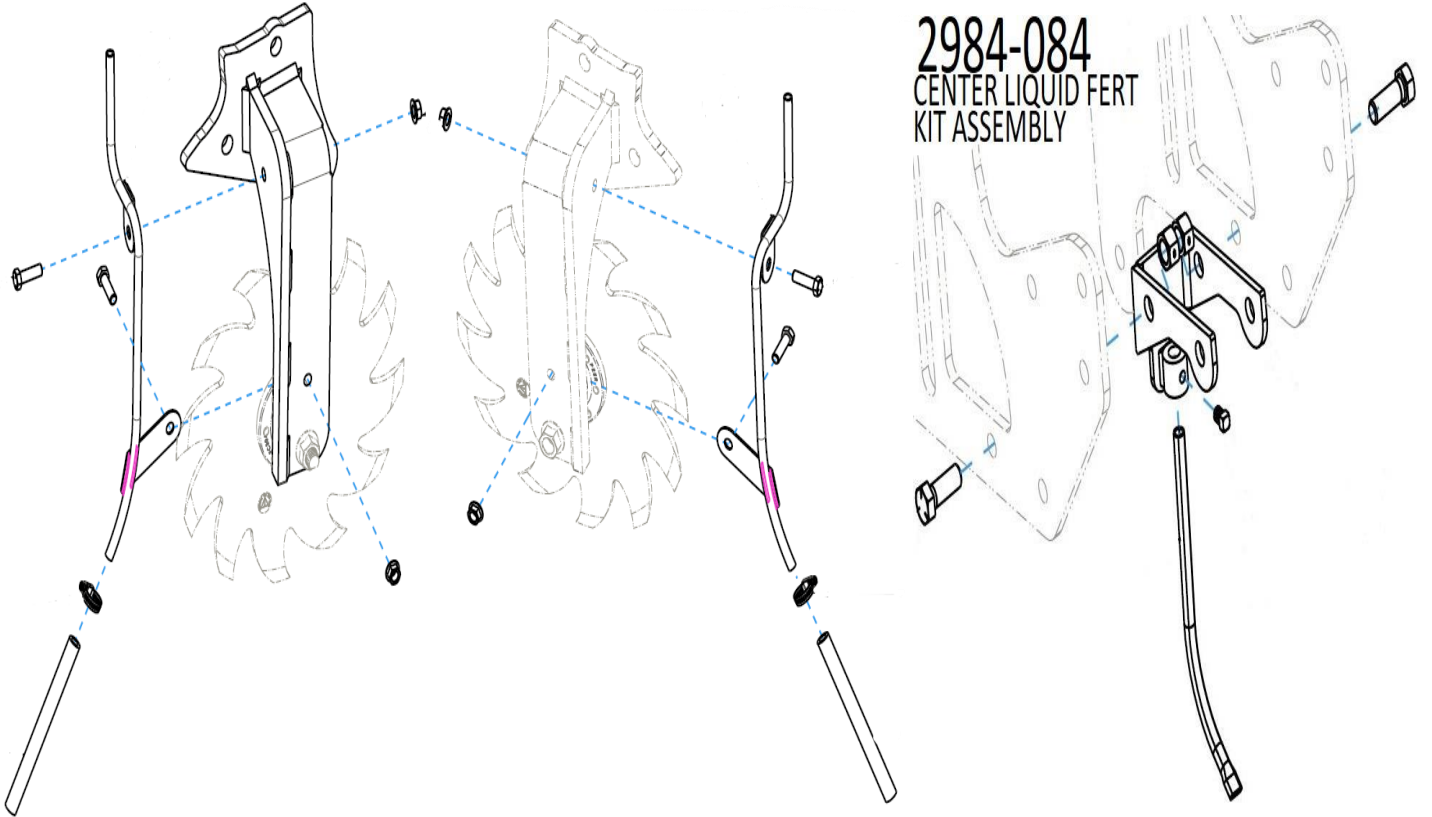

# OPERATION PRECAUTIONS

# STOP

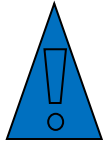

Read this before using the Yetter product.

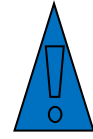

## MACHINE OPERATION

### Pneumatic System Check:

Make sure the toolbars compressor source is engaged. Allow the compressor to engage & complete 1 full cycle before applying pressure to any circuit.

Pull the selector valve knob for the row cleaner circuit. Pull the regulator knob (unlock) for the row cleaner up pressure circuit adjustment & turn the knob until ALL row cleaners move to the up position. Push the regulator knob back in to lock in place. Pull the regulator knob for the row unit down force circuit adjustment & turn the knob until the row unit down force gauge reads 50psi on the cab controller. Push the regulator knob back in to lock in place. Pull the selector valve knob for the rolling basket circuit. Pull the regulator knob for the rolling basket up pressure circuit adjustment & turn the knob until ALL rolling baskets move to the up position. Push the regulator knob back in to lock in place. Exit the tractor cab inspecting the blue, orange, & yellow airline at the bulkhead connector at hitch & all 3 of the circuits that have air pressure applied (row cleaner up, row unit down force, & rolling basket up). Check for leaks at the tee fittings, air fittings at the cylinders/air bags, & each cylinder/air bag. Repair leaks as needed. Once each of these 3 circuits is leak free, return to the tractor cab.

Push the selector valve for the row cleaner & rolling basket in (all rolling baskets and row cleaners should lower). Pull the regulator knob for the row cleaner down pressure circuit adjustment & turn the knob until the row cleaner gauge reads 50psi. Push the regulator knob back in to lock in place. Pull the regulator knob for the rolling basket down pressure circuit adjustment & turn the knob until the rolling basket gauge reads 50psi. Push the regulator knob back in to lock in place. Exit the tractor cab inspecting the black & green airline at the bulkhead connector at hitch. Lift each row cleaner & rolling basket to ensure down pressure in each cylinder is present & equally applied to each row. Check for leaks at each tee bank, air fittings at the cylinders, & each cylinder. Once all circuits are leak free, return to the tractor cab & return all adjustable circuits to 0psi. Pull the Row Lock to vent the row unit down force to 0psi & then push back in.

### Row Unit Check:

Inspect each individual strip freshener CC unit for loose or damaged hardware. Make sure all pivot points (row unit parallel linkage, row cleaner, rolling basket) travel freely.



**NOTICE:** failure to properly set frame height & levelness can result in less than successful operation of Yetter product & may result in damaged equipment. All operators should read & thoroughly understand the instructions given prior to using the Yetter product.

**DO NOT** use this product if the toolbar is not adjusted properly!

### Leveling the Toolbar:

Lower operating Toolbar Frames, such as planters, need to have toolbar height adjust to 21"-23" with the rear of parallel arms in the lower holes on the strip freshener CC side plates.

Higher operating Toolbar Frames need to have toolbar height adjusted to 24-26" with rear of parallel arms in the upper holes on the strip freshener CC side plates.

**SEE DIMENSIONS DIAGRAM AT THE BOTTOM OF [PAGE 4](#)**

With the frame lowered to proper operating height (**Usually 22"-26"**, depending on toolbar application) Check to be sure toolbar is level side to side. **Check** when toolbar is in **field** & has been **fully loaded** with fertilizer, etc. Also, a field check with a bubble level on the frame should be made of the hitch height to ensure level operation front to back.

It is important for the toolbar to operate level laterally. Tire pressure must be maintained at pressures specified by the manufacturer.

Field conditions change and will dictate toolbar frame heights. Lower the toolbar and pull forward to allow units to get to desired depth & then recheck toolbar levelness.

Row unit parallel linkage should be parallel to the ground or slightly downhill from front to back.

# OPERATION PRECAUTIONS

To ensure hydraulic compressor motor doesn't exceed recommended operating RPM level, the hydraulic oil flow control valve has been preset. In some instances, compressor may run below optimum rpm, or will not reach 145psi of tank pressure read at the gauge on compressor unit. If this is the case, an adjustment to the flow control valve will need made. Only open the flow control valve enough to allow the compressor to build to 145psi tank pressure read at the gauge on the compressor unit. Opening the flow control too far could cause over speeding and reduced service life of the compressor. Follow the instructions below to make the proper adjustment.

**NOTE: Before making any adjustments to the flow control valve, adjust the tractor hydraulic flow fully open. Adjusting the tractor's hydraulic flow will affect the compressor's RPM. The hydraulic motor speed on the hydraulic compressor should not exceed 1350RPM. RPM's on the hydraulic compressor may be checked via the fan blades with an optical tachometer.**

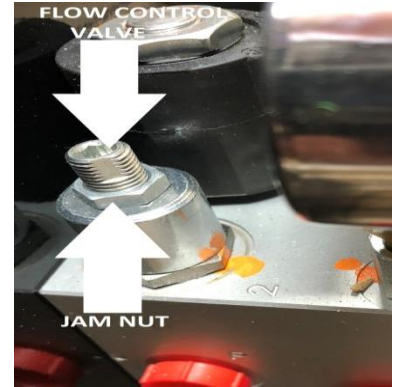
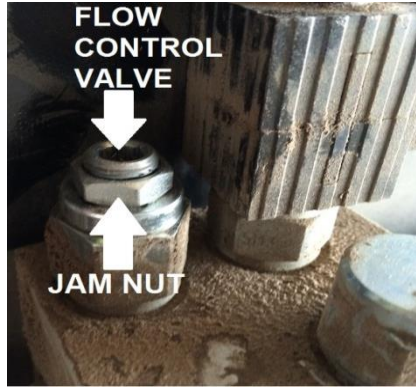

- STEP 1:** Remove the black seal from hydraulic flow control valve and jam nut (2018 & newer hyd. compressors will not have seal).
- STEP 2:** Flip the switch to ON on the 2984 Strip Freshener control box & supply hydraulic pressure to the compressor.  
**Make adjustments while hydraulic motor is running.** Open tank drain to allow continuous running if necessary.
- STEP 3:** Insert an Allen wrench into flow control valve. 2013 - 05/2018 models use a 5/16, 06/2018 – present use a 3/16.
- STEP 4:** Loosen jam nut by turning counterclockwise. 2013 - 05/2018 models use a 11/16, 06/2018 – present use a 1/2.
- STEP 5:** Using Allen wrench, **SLIGHTLY** turn flow control valve counterclockwise (the equivalent to 3 degrees or 1/32 of a turn) to increase the hydraulic motor speed.
- STEP 6:** Hold the Allen wrench in place and tighten the jam nut. Each time an adjustment is made, allow the compressor to build to its potential 145psi shut off mark. If 145psi is not achieved, drain tank pressure until compressor turns on, and make another adjustment. Repeat these steps until 145psi is achieved so that the compressor runs smoothly without struggle. **DO NOT RUN MOTOR ON COMPRESSOR MORE THAN 1350RPM!** RPMs can be checked with an optical tachometer using the fan blades. Once the flow control valve is set properly, hold the Allen wrench in place and tighten the jam nut.

## OPERATION

The Tank Pressure should always be above 100psi. If using Yetter Electric/Hydraulic Compressor units, each compressor will shut off at 145psi & engage to recover back to 145psi when tank pressure drops to 120psi. Make sure to have all circuits set at 0psi when setting the toolbar & units for optimum performance begins. Follow these steps to set the strip freshener CC units to achieve the best results:

- Step 1:** Set depth (approximate) on each row unit. Adjust screw adjust knob (15/16 wrench) to achieve your preferred depth. Adjustments can be made in 1/4" increments. Rotating the screw adjust knob clockwise will raise the gauge wheels making the units go deeper. Rotating the screw adjust knob counterclockwise will lower the gauge wheels making the units go shallower. The depth decal on the side of each unit is only a reference & NOT an actual depth in inches as to where the unit is set. For example, 3 does not mean 3 inches deep necessarily. Actual depth is determined by how low the cutting coulters is below the gauge wheels. Other factors can play in to setting the depth such as row cleaner and rolling basket settings.
- Step 2:** Apply row unit down force until each unit's ride is consistent, smooth, & correct depth is achieved. **Row Unit Downforce should never be above 100psi.** Row unit down force may need re-adjusted once the row cleaner is set properly. Push Row Lock down to lock pressure in circuit. To lower DF pressure, pull regulator knob to unlock, rotate knob counterclockwise, pull row lock knob out for 3-5seconds, push row lock knob back in. Repeat as necessary until desired pressure is achieved & then push regulator knob in to lock. To add DF pressure, simply pull regulator knob out, rotate clockwise to desired pressure, & push regulator knob in to lock.
- Step 3:** Fine tune the row cleaners by applying up or down pressure. Row cleaners should only be cleaning residue from the strip & not engaging the soil.
- Step 4:** Apply pressure to rolling basket to condition strip & incorporate fertilizer if applicable. Row unit downforce needs readjusted once rolling basket is set.
- Step 5:** Recheck depth of each row unit & condition of strips, adjust as needed. (SEE STEP 1) Check depth on each row by removing loose soil until bottom of each strip is found. For most accurate measurement, remove residue away from top of soil surface next to each strip where measuring & measure from bottom of each strip to top of soil surface.

## INITIAL SETTINGS

	<u>FRESHENING STRIPS</u>	<u>NEW STRIPS</u>
<b>Row Unit DF:</b>	20-35psi	40-60psi
<b>Row Cleaners:</b>	20-40psi UP	15-25psi DN
<b>Rolling Basket:</b>	30psi DN	30psi DN

**These are just starting point recommendations Adjustments to these settings may be necessary for optimal performance for your conditions**

# OPERATION

**ROW CLEANER UP PRESSURE CONTROL**  
PULL KNOB TO UNLOCK  
TURN CLOCKWISE TO INCREASE AIR  
TURN COUNTERCLOCKWISE TO DECREASE AIR  
PUSH KNOB TO LOCK

**ROW CLEANER DOWN PRESSURE CONTROL**  
PULL KNOB TO UNLOCK  
TURN CLOCKWISE TO INCREASE AIR  
TURN COUNTERCLOCKWISE TO DECREASE AIR  
PUSH KNOB TO LOCK

**ROW CLEANER SELECTOR VALVE**  
PULL UP TO APPLY AIR TO UP PRESSURE SIDE OF ROW CLEANER CYLINDER  
PUSH DOWN TO APPLY AIR TO DOWN PRESSURE SIDE OF ROW CLEANER CYLINDER

**TANK PRESSURE FROM AIR SOURCE**  
MINIMUM OF 100PSI  
MAXIMUM OF 145PSI

**ROW LOCK**  
PULL UP TO VENT AIR IN ROW UNIT DOWNFORCE CIRCUIT  
PUSH DOWN TO LOCK AIR IN ROW UNIT DOWNFORCE CIRCUIT

**ROLLING BASKET SELECTOR VALVE**  
PULL UP TO APPLY AIR TO UP PRESSURE SIDE OF ROLLING BASKET AIR CYLINDER  
PUSH DOWN TO APPLY AIR TO DOWN PRESSURE SIDE OF ROLLING BASKET CYLINDER

**ROLLING BASKET UP PRESSURE CONTROL**  
PULL KNOB TO UNLOCK  
TURN CLOCKWISE TO INCREASE AIR  
TURN COUNTERCLOCKWISE TO DECREASE AIR  
PUSH KNOB TO LOCK

**ROW CLEANER PRESSURE GAUGE**

**ROW UNIT DOWNFORCE PRESSURE CONTROL**  
PULL KNOB TO UNLOCK  
TURN CLOCKWISE TO INCREASE AIR  
TURN COUNTERCLOCKWISE TO DECREASE AIR (MUST ALSO PULL ROW LOCK TO DECREASE AIR & THEN PUSH TO LOCK AGAIN)  
PUSH KNOB TO LOCK

**ROW UNIT DOWNFORCE PRESSURE GAUGE**

**ROLLING BASKET PRESSURE GAUGE**

**ROLLING BASKET DOWN PRESSURE CONTROL**  
PULL KNOB TO UNLOCK  
TURN CLOCKWISE TO INCREASE AIR  
TURN COUNTERCLOCKWISE TO DECREASE AIR  
PUSH KNOB TO LOCK

Row Unit Parallel

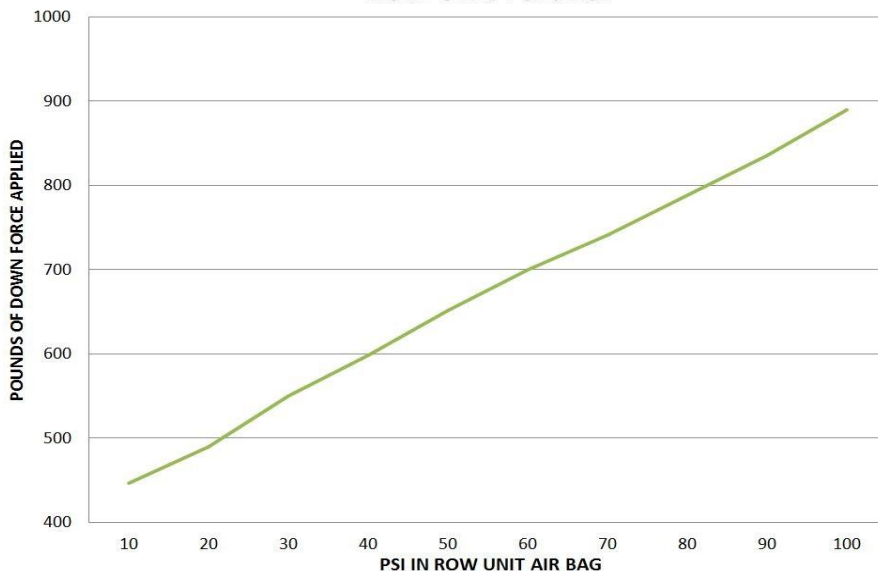

# MAINTENANCE

## Yetter Compressor Maintenance

### WARNING:



Keep extremities out of the compressor housing when compressor is running, has potential to run, or recently shut off as there are rotating & high temperature parts that may cause injury. Always turn tractor off & disconnect power before performing any maintenance.

### LUBRICATION:

Hydraulic compressors are shipped empty of pump lubrication & need oil added before operation. Provided is a 1 Liter bottle of grade 111 synthetic. Add oil until oil level is seen half way up on the sight glass. Recheck oil level on the dipstick. Yetter part # for new bottle is 2940-550.

### GUARDS:

Always ensure the housing and guards are in place during operation.

### AIR FILTER CARTRIDGE:

Hydraulic Compressor Filter Part # - 2940-549. Electric Compressor Filter Part # - 2940-395, Pre-Cleaner Part # - 2940-396

## MAINTENANCE SCHEDULE GUIDE

### DAILY

- Check oil level and fill as needed (**hydraulic compressor only**)
- Check air filter cleanliness and clean/replace as needed
- Check hoses for fluid leaks and replace/fix as needed
- Check air lines for air leaks and replace/fix as needed
- Check component parts of the compressor for damage (pressure switch, cooling fan, gauge, etc)
- Open Tank Drain Valve (10 seconds) (**see illustration to the right**) to allow moisture to drain----->

Closed



Open

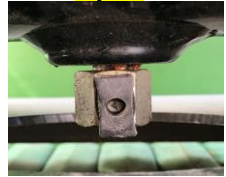

### SEASONALLY/200 COMPRESSOR HOURS

- Change compressor oil (**hydraulic compressor only**)
- Change inlet air filter
- Check fluid hoses and air lines for weakness or weathering and replace as needed.
- Check hydraulic fittings for proper connections with no leaks, replace as needed.



**FIRST OIL CHANGE SHOULD TAKE PLACE AFTER APPROXIMATELY 50 RUNNING HOURS (hydraulic compressor only)**

### CLEANING OR REPLACING THE 2940-106 AIR FILTER

#### 2015 – 2016 MODEL



#### 2017 – PRESENT MODEL



Filter cleanliness is critical to maintain the performance & service life of the compressor. Recommendations for cleaning are DAILY & replace every 200 hours OR at beginning of every planting season. Dirt sucked passed the filter will ruin the pump.

**STEP 1:** Remove the wing nut & filter cover.

**STEP 2:** Remove the filter. (If cleaning, tap the filter on a solid surface to remove dirt from the pleats & clean the filter base. **DO NOT USE COMPRESSED AIR TO CLEAN FILTER!**)

**STEP 3:** Install new or cleaned filter.

**STEP 4:** Install filter cover & wing nut removed in step 1. **TIGHTEN WING NUT SECURELY**

### REPLACING THE COOLING FAN (HYDRAULIC COMPRESSOR)

Remove the filter cover & filter, remove housing (6 bolts), remove hydraulic motor (2 bolts), loosen LH bolt on the end of the shaft, remove the coupler, & replace fan. Reassemble coupler on shaft & tighten LH bolt, reinstall the hydraulic motor, & reassemble the housing, filter, & filter cover. Removing the coupler from the shaft may be difficult. Use a pry bar to hold pressure on the coupler, unthread the LH bolt halfway, & tap with a hammer. Rotate the fan some & repeat this process until coupler breaks loose.

# MAINTENANCE



- Step 1:** Remove the pre-cleaner (if equipped) from the filter cover. Remove the filter cap by turning the cap clockwise.  
**Step 2:** Clean the pre-cleaner & filter. Replace if needed.  
**Step 3:** Install the filter & filter cap, placing the tab in the slots & turning the cap counter clockwise. Make sure the breather hole on the filter cap is facing down. Install the pre-cleaner.

 **Lubricate all bearings and moving parts as assembled and make certain that they work freely.**  
**WARNING:** Never work around the toolbar/implement while in a raised position without using safety lockups.

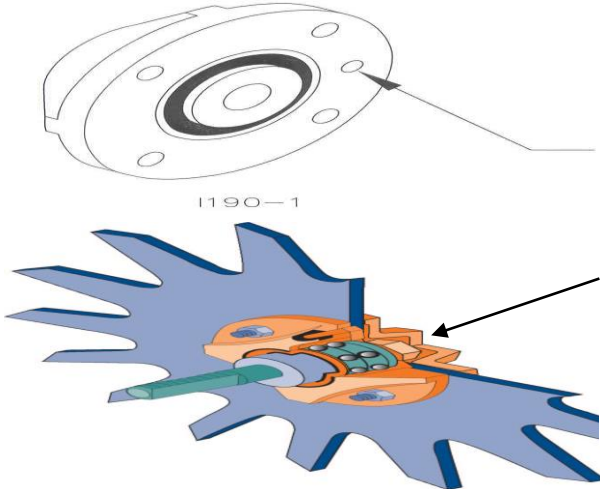



ALIGN GREASE FITTING HOLES.

**2021 – Older Hub/Bearing Assemblies**  
 Grease must fill this hub cap cavity.

**2022 – Present Hub/Bearing Assemblies**  
 DO NOT have a grease zerk.

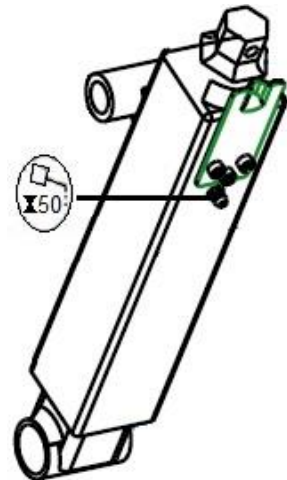
**This applies to row cleaner wheel & berming disc wheel assemblies.**



 **CAUTION:** To help prevent serious injury or death to you or other caused by unexpected movement, service machine on a level surface. Lower machine to ground or sufficiently lock or block raised machine before servicing. If machine is connected to a tractor, engage parking brake, place transmission in PARK, shut off engine, & remove the key. If machine is detached from a tractor, block wheel & use shop stands to prevent movement.

 **CAUTION:** Do not clean, lubricate, or adjust a machine while in motion.

Use grease based on NLGI consistency number and the expected air temperature range during the service interval.

Use a **multi-purpose polyurea, water resistant, moderate speed, and NLGI grade #2** grease.

Other greases may be used if they meet the **NLGI Performance Classification: GC-LB**

**Important:** Some types of grease thickener are not compatible with others. Consult your grease supplier before mixing different types of grease.

## Alternative Lubricants

Conditions in certain geographical areas may require special lubricants and lubrication practices which do not appear in the operator's manual. If there are any questions, consult Yetter Manufacturing Co. to obtain the latest information & recommendation.

Part #	Description	Ounces of Grease
2967-404	13" Taper Tooth RM Wheel	1.12 Oz
2967-602	13" Shark Tooth RM Wheel	1.12 Oz
2967-186	Floater Wheel Kit w/ RM Wheel	2.08 Oz
2967-596	Heavy Duty or Bevel R.M. Wheel W/Floater Wheel Kit	2.40 Oz
2571-601	13" Shark Tooth Finger Wheel	1.12 Oz

**Refilling cavity with grease on each wheel assembly every 50 hours is required!**

All bearings on this unit are sealed bearings. Grease is needed to fill hub cavity to protect seal from damage/contaminants.

## Storing Lubricants

Your machine can operate at peak efficiency only if clean lubricants are used. Use clean containers to handle all lubricants. Store them in an area protected from dust, moisture, and other contaminants.

## 2984-168 SMALL PARTS KIT IDENTIFICATION

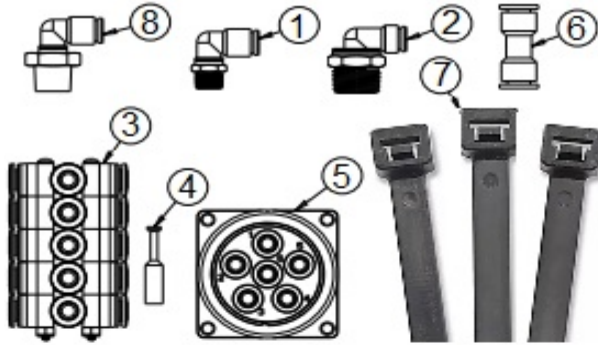

ITEM	PART #	DESCRIPTION	QTY
1	1200-323	1/4" TUBE TO 1/8NPT MALE 90° SWIVEL	2
2	2515-307	1/4" TUBE X 3/8NPTM 90° SWIVEL	4
3	2515-903	5 CIRCUIT 1/4" TEE BANK ASSEMBLY	7
4	2515-904	1/4" PUSH PLUG	32
5	2515-907	6 PORT FLNG MOUNT PUSH CONNECTOR	1
6	2515-911	1/4" PUSH IN STRT UNION	4
7	2940-148	PKG OF 100 ZIP TIES	4
8	2940-423	1/4" TUBE X 1/4"NPT MALE 90° SWIVEL	4

## AIR LINE KIT PART IDENTIFICATION

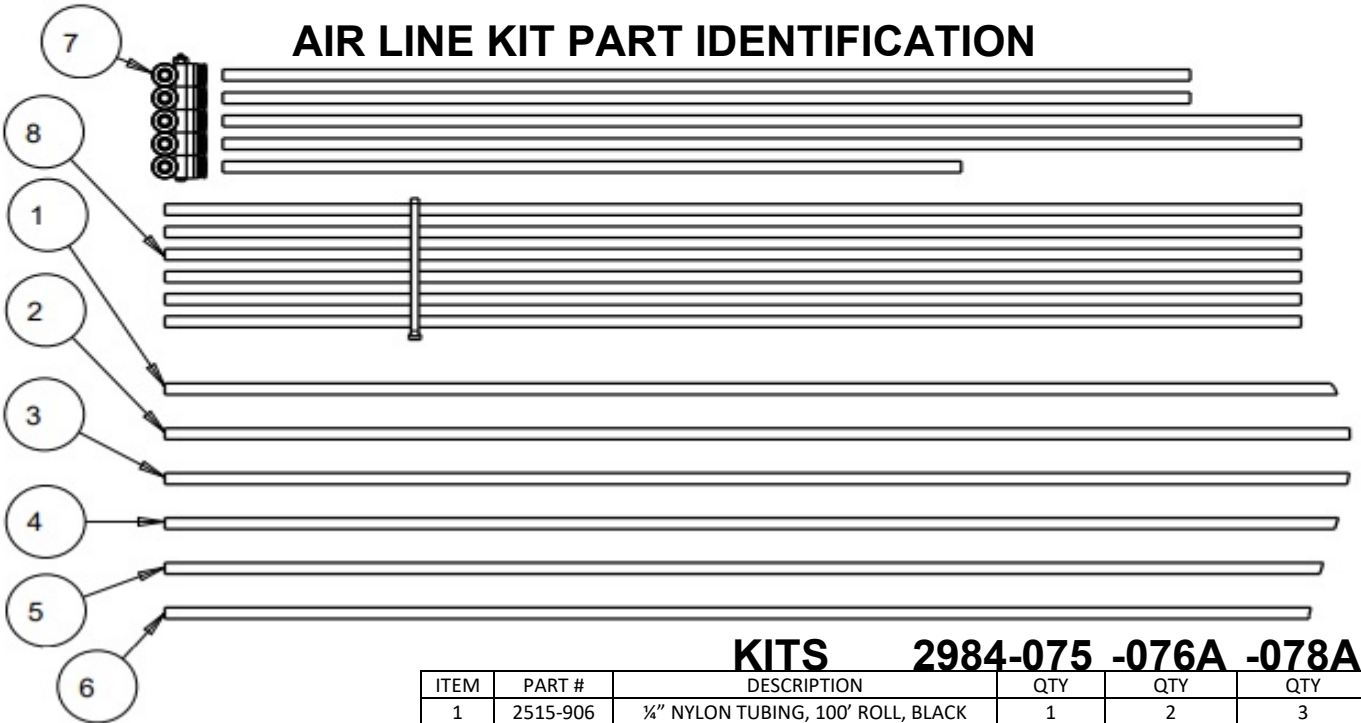

## KITS 2984-075 -076A -078A

ITEM	PART #	DESCRIPTION	QTY	QTY	QTY
1	2515-906	1/4" NYLON TUBING, 100' ROLL, BLACK	1	2	3
2	2515-908	1/4" NYLON TUBING, 100' ROLL, BLUE	1	2	3
3	2515-909	1/4" NYLON TUBING, 100' ROLL, ORANGE	1	2	3
4	2515-910	1/4" NYLON TUBING, 100' ROLL, RED	1	1	1
5	2515-913	1/4" NYLON TUBING, 100' ROLL, GREEN	1	2	3
6	2515-914	1/4" NYLON TUBING, 100' ROLL, YELLOW	1	2	3
7	2984-161	ROW UNIT AIR LINE BUNDLE	12	16	24
8	2984-162	CAB TO HITCH AIRLINE BUNDLE	1	1	1

# PART IDENTIFICATION

## 2984-050E-R-ST STRIP FRESHENER CC

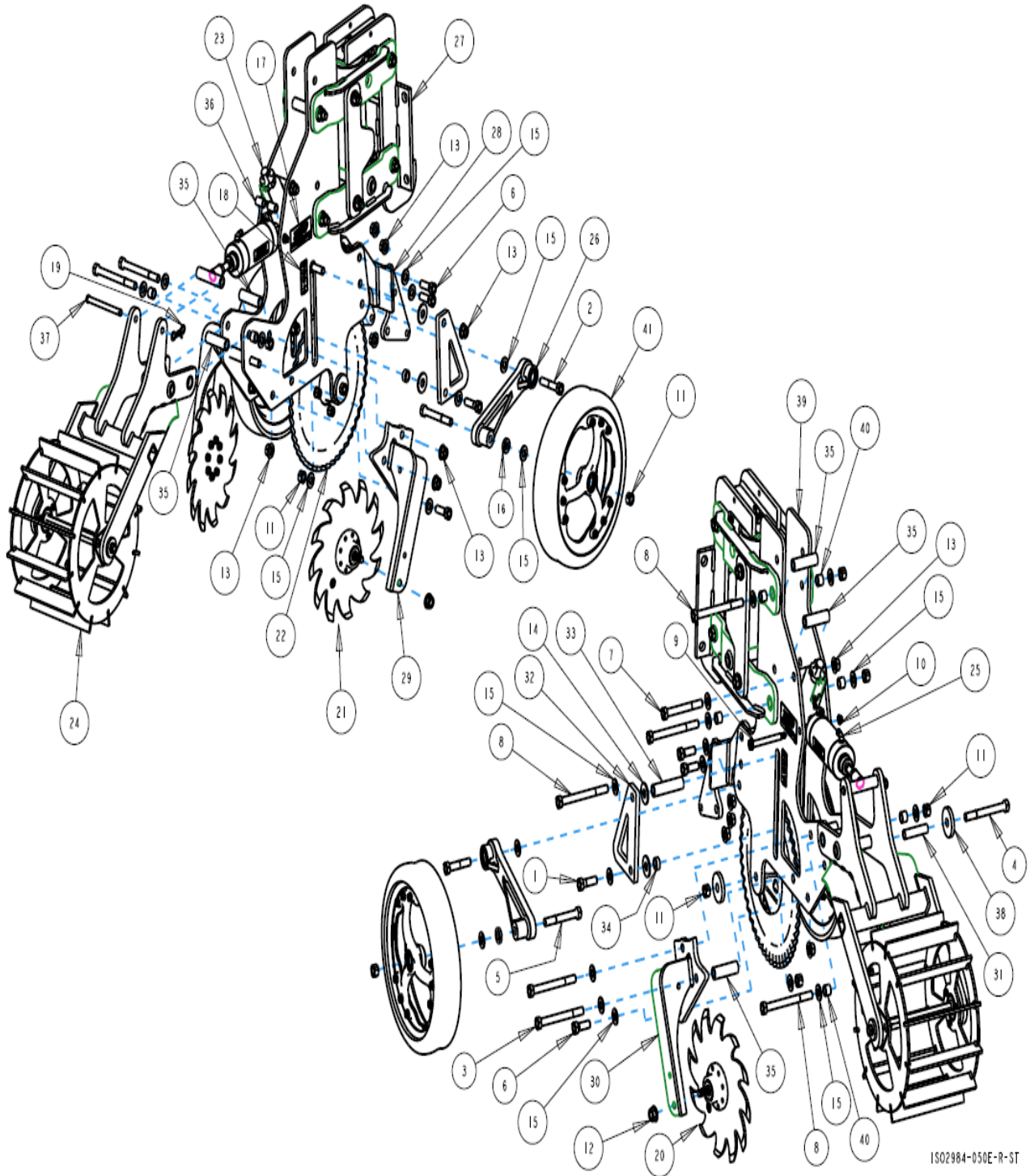

ISO2984-050E-R-ST

**PART IDENTIFICATION**  
**2984-050E-R-ST STRIP FRESHENER CC**

ITEM	PART NO.	DESCRIPTION	QTY
1	2502-322	5/8-11 x 2 HHCS GR 8	2
2	2502-330	5/8-11 X 3 HHCS GRADE 8 ZP	2
3	2502-352	5/8-11 X 6 HHCS GRADE 8 ZP	2
4	2502-384	5/8-11 X 5.5 HHCS GR8 ZP	1
5	2502-433	5/8-11 X 4-1/2 HHCS GR8 ZP	2
6	2502-440	5/8-11 X 1 3/4 HHCS GR8 ZP	6
7	2502-441	5/8-11 X 5 HHCS GR 8 ZP	1
8	2502-444	5/8-11 X 6-1/2" HHCS GR8 ZP	4
9	2510-312	1/2" DIA. X 4" L SHOULDER SCREW	1
10	2520-252	3/8-16 HEX FLANGE TOP LOCK NUT, GR G, ZP	1
11	2520-462	5/8-11 HEX LOCK NUT GR 8 ZP	8
12	2520-465	5/8-11 SER. FLANGE NUT, GR 8, ZP	2
13	2520-478	5/8-11 SER. FLNG NUT, GR 8, ZP W/THDLOCK	12
14	2526-451	5/8 STD FLATWASHER ZP	4
15	2526-454	5/8 SAE FLATWASHER HRD'ND ZP	24
16	2526-455	WASH 21/32" X 1 1/4" X 1/4	2
17	2565-356	STRIP FRESHENER DECAL	2
18	2565-836	ADJUSTMENT DECAL	2
19	2570-448	.120 BOWTIE LOCKING COTTER ZP	1
20	2966-140-ST	SHARKTOOTH ASSY,RH,3" D-BOLT	1
21	2966-141-ST	SHARKTOOTH ASSY,LH,3" D-BOLT	1
22	2984-143	RIPPLE BLADE ASSEMBLY	1
23	2984-144	DEPTH ADJUST ASSEMBLY	1
24	2984-146	ROLLING BASKET ASSEMBLY, 2984-050	1
25	2984-153	AIR CYLINDER ASSEMBLY	1
26	2984-157	GAUGE WHEEL ARM ASS'Y	2
27	2984-158A	PARALLEL ARM ASSEMBLY (1/4" AIR FITTINGS)	1
28	2984-241	RM ARM MOUNT W.A.	1
29	2984-248A	R.H. SHARKTOOTH MOUNT W.A.	1
30	2984-249A	L.H. SHARKTOOTH MOUNT W.A.	1
31	2984-455	BEARING BORE ADAPTER, ZP	1
32	2984-468	DEPTH STOP	2
33	2984-469	TOP DEPTH STOP BUSHING	1
34	2984-470	DEPTH ADJ LOWER BUSHING	2
35	2984-479	CROSS BUSHING	5
36	2984-495	STRUT BUSHING SHORT	2
37	2984-497	AIR CYLINDER ROD PIN	1
38	2984-501	WASHER, .688ID X 2.50 OD X .375THK	2
39	2984-551	SIDE PLATE	2
40	2984-565	BUSHING, CHROME PLATED	6
41	6000-070	3" X 16" SPOKED GAUGE WHEEL (2023)	2

ISO2984-050E-R-ST

# PART IDENTIFICATION

## 2984-050E-R-SW STRIP FRESHENER CC

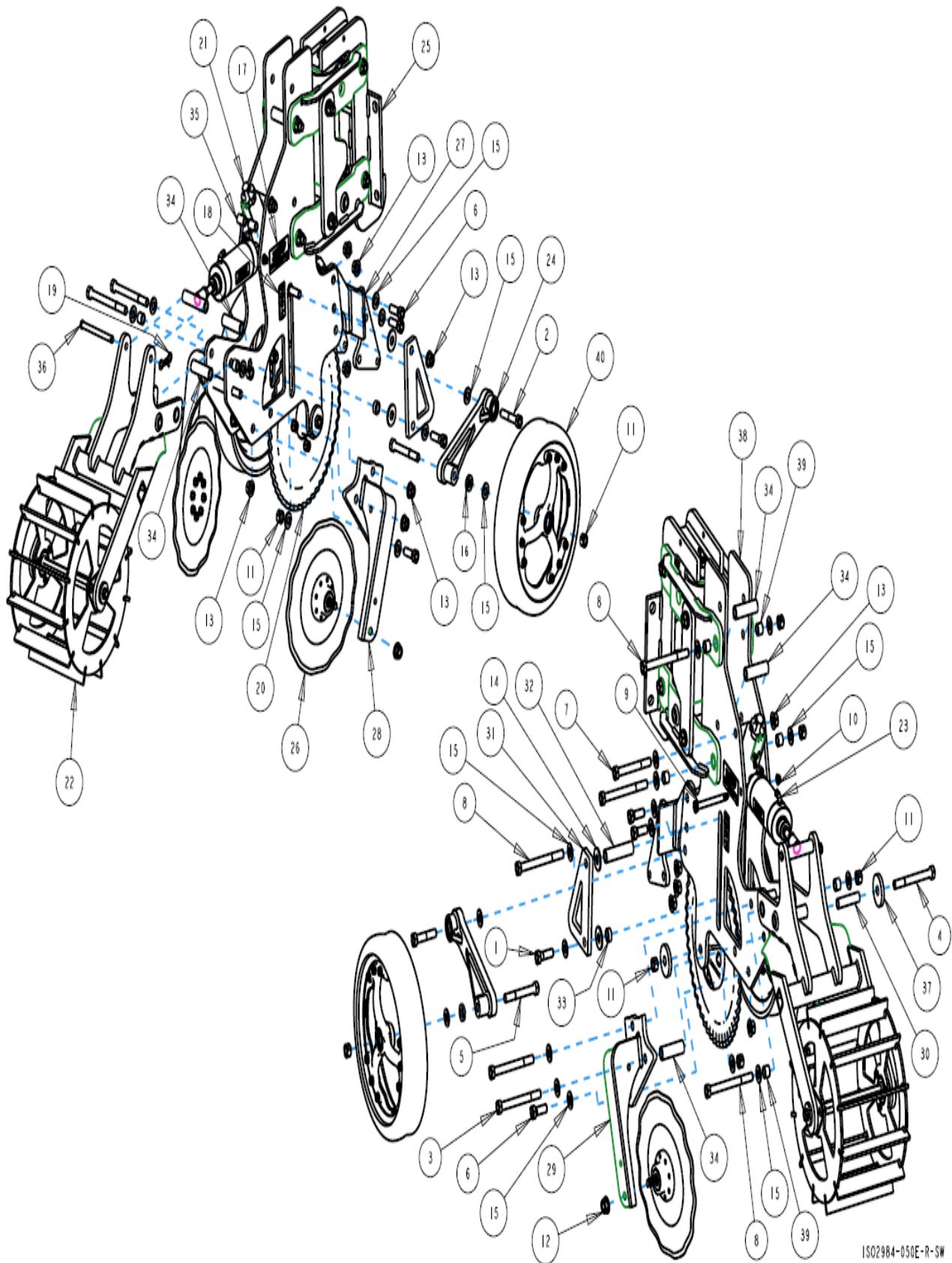

ISO2984-050E-R-SW

## PART IDENTIFICATION

### 2984-050E-R-SW STRIP FRESHENER CC

ITEM	PART NO.	DESCRIPTION	QTY
1	2502-322	5/8-11 x 2 HHCS GR 8	2
2	2502-330	5/8-11 X 3 HHCS GRADE 8 ZP	2
3	2502-352	5/8-11 X 6 HHCS GRADE 8 ZP	2
4	2502-384	5/8-11 X 5.5 HHCS GR8 ZP	1
5	2502-433	5/8-11 X 4-1/2 HHCS GR8 ZP	2
6	2502-440	5/8-11 X 1 3/4 HHCS GR8 ZP	6
7	2502-441	5/8-11 X 5 HHCS GR 8 ZP	1
8	2502-444	5/8-11 X 6-1/2" HHCS GR8 ZP	4
9	2510-312	1/2" DIA. X 4" L SHOULDER SCREW	1
10	2520-252	3/8-16 HEX FLANGE TOP LOCK NUT, GR G, ZP	1
11	2520-462	5/8-11 HEX LOCK NUT GR 8 ZP	8
12	2520-465	5/8-11 SER. FLANGE NUT, GR 8, ZP	2
13	2520-478	5/8-11 SER. FLNG NUT, GR 8, ZP W/THDLOCK	12
14	2526-451	5/8 STD FLATWASHER ZP	4
15	2526-454	5/8 SAE FLATWASHER HRD'ND ZP	24
16	2526-455	WASH 21/32" X 1 1/4" X 1/4	2
17	2565-356	STRIP FRESHENER DECAL	2
18	2565-836	ADJUSTMENT DECAL	2
19	2570-448	.120 BOWTIE LOCKING COTTER ZP	1
20	2984-143	RIPPLE BLADE ASSEMBLY	1
21	2984-144	DEPTH ADJUST ASSEMBLY	1
22	2984-146	ROLLING BASKET ASSEMBLY, 2984-050	1
23	2984-153	AIR CYLINDER ASSEMBLY	1
24	2984-157	GAUGE WHEEL ARM ASS'Y	2
25	2984-158A	PARALLEL ARM ASSEMBLY (1/4" AIR FITTINGS)	1
26	2984-159	13 WAVE WHEEL ASSEMBLY	2
27	2984-241	RM ARM MOUNT W.A.	1
28	2984-248A	R.H. SHARKTOOTH MOUNT W.A.	1
29	2984-249A	L.H. SHARKTOOTH MOUNT W.A.	1
30	2984-455	BEARING BORE ADAPTER, ZP	1
31	2984-468	DEPTH STOP	2
32	2984-469	TOP DEPTH STOP BUSHING	1
33	2984-470	DEPTH ADJ LOWER BUSHING	2
34	2984-479	CROSS BUSHING	5
35	2984-495	STRUT BUSHING SHORT	2
36	2984-497	AIR CYLINDER ROD PIN	1
37	2984-501	WASHER, .688ID X 2.50 OD X .375THK	2
38	2984-551	SIDE PLATE	2
39	2984-565	BUSHING, CHROME PLATED	6
40	6000-070	3" X 16" SPOKED GAUGE WHEEL (2023)	2

ISO2984-050E-R-SW

# PART IDENTIFICATION

## 2984-051B-R-ST STRIP FRESHENER CC

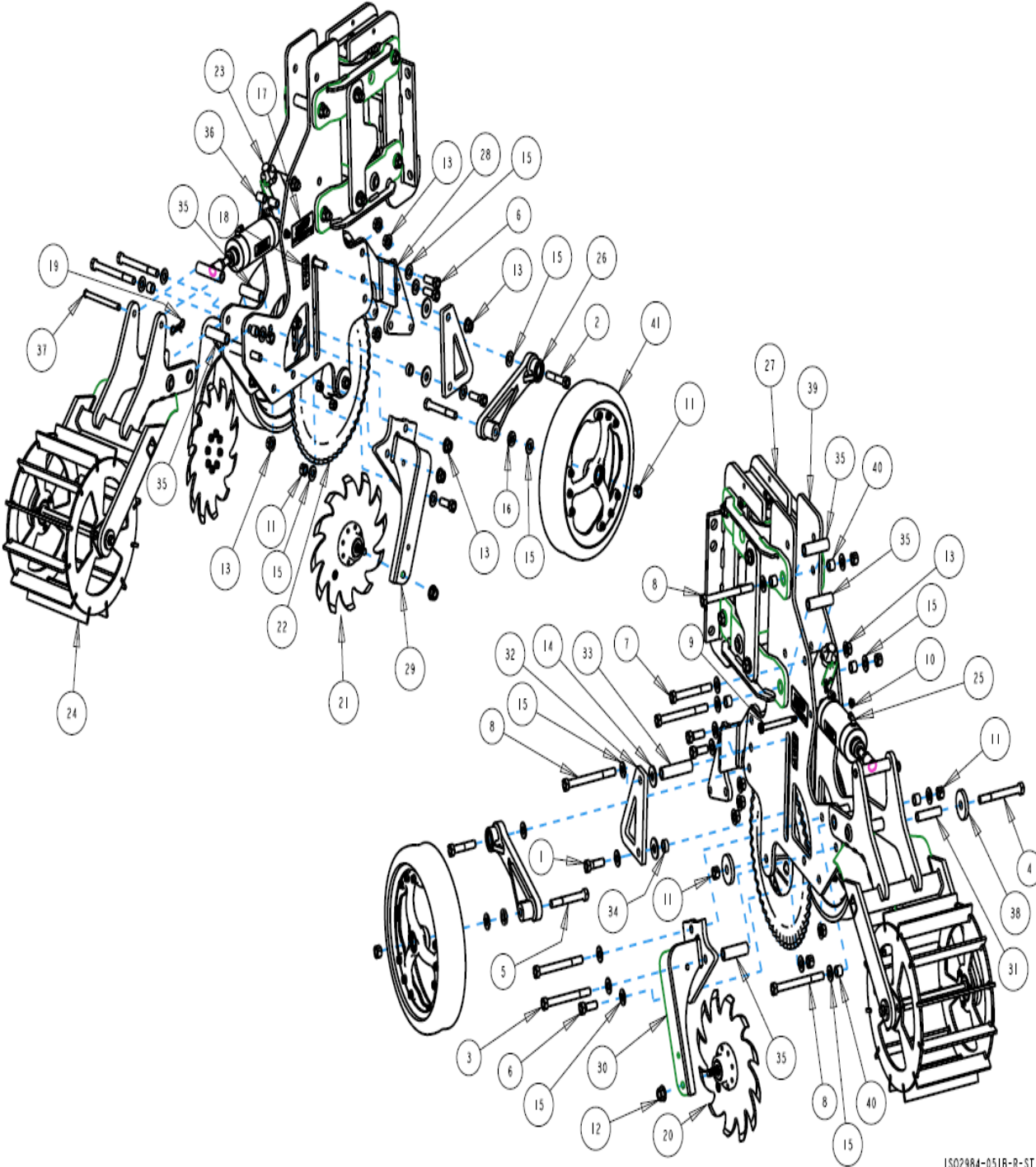

ISO2984-051B-R-ST

**PART IDENTIFICATION**  
**2984-051B-R-ST STRIP FRESHENER CC**

ITEM	PART NO.	DESCRIPTION	QTY
1	2502-322	5/8-11 x 2 HHCS GR 8	2
2	2502-330	5/8-11 X 3 HHCS GRADE 8 ZP	2
3	2502-352	5/8-11 X 6 HHCS GRADE 8 ZP	2
4	2502-384	5/8-11 X 5.5 HHCS GR8 ZP	1
5	2502-433	5/8-11 X 4-1/2 HHCS GR8 ZP	2
6	2502-440	5/8-11 X 1 3/4 HHCS GR8 ZP	6
7	2502-441	5/8-11 X 5 HHCS GR 8 ZP	1
8	2502-444	5/8-11 X 6-1/2" HHCS GR8 ZP	4
9	2510-312	1/2" DIA. X 4" L SHOULDER SCREW	1
10	2520-252	3/8-16 HEX FLANGE TOP LOCK NUT, GR G, ZP	1
11	2520-462	5/8-11 HEX LOCK NUT GR 8 ZP	8
12	2520-465	5/8-11 SER. FLANGE NUT, GR 8, ZP	2
13	2520-478	5/8-11 SER. FLNG NUT, GR 8, ZP W/THDLOCK	12
14	2526-451	5/8 STD FLATWASHER ZP	4
15	2526-454	5/8 SAE FLATWASHER HRD'ND ZP	24
16	2526-455	WASH 21/32" X 1 1/4" X 1/4	2
17	2565-356	STRIP FRESHENER DECAL	2
18	2565-836	ADJUSTMENT DECAL	2
19	2570-448	.120 BOWTIE LOCKING COTTER ZP	1
20	2966-140-ST	SHARKTOOTH ASSY,RH,3" D-BOLT	1
21	2966-141-ST	SHARKTOOTH ASSY,LH,3" D-BOLT	1
22	2984-143	RIPPLE BLADE ASSEMBLY	1
23	2984-144	DEPTH ADJUST ASSEMBLY	1
24	2984-146	ROLLING BASKET ASSEMBLY, 2984-050	1
25	2984-153	AIR CYLINDER ASSEMBLY	1
26	2984-157	GAUGE WHEEL ARM ASS'Y	2
27	2984-160A	PARALLEL ARM ASSEMBLY, 7X7 & 7X9 TOOLBARS	1
28	2984-241	RM ARM MOUNT W.A.	1
29	2984-248A	R.H. SHARKTOOTH MOUNT W.A.	1
30	2984-249A	L.H. SHARKTOOTH MOUNT W.A.	1
31	2984-455	BEARING BORE ADAPTER, ZP	1
32	2984-468	DEPTH STOP	2
33	2984-469	TOP DEPTH STOP BUSHING	1
34	2984-470	DEPTH ADJ LOWER BUSHING	2
35	2984-479	CROSS BUSHING	5
36	2984-495	STRUT BUSHING SHORT	2
37	2984-497	AIR CYLINDER ROD PIN	1
38	2984-501	WASHER, .688ID X 2.50 OD X .375THK	2
39	2984-551	SIDE PLATE	2
40	2984-565	BUSHING, CHROME PLATED	6
41	6000-070	3" X 16" SPOKED GAUGE WHEEL (2023)	2

ISO2984-051B-R-ST

# PART IDENTIFICATION

## 2984-051B-R-SW STRIP FRESHENER CC

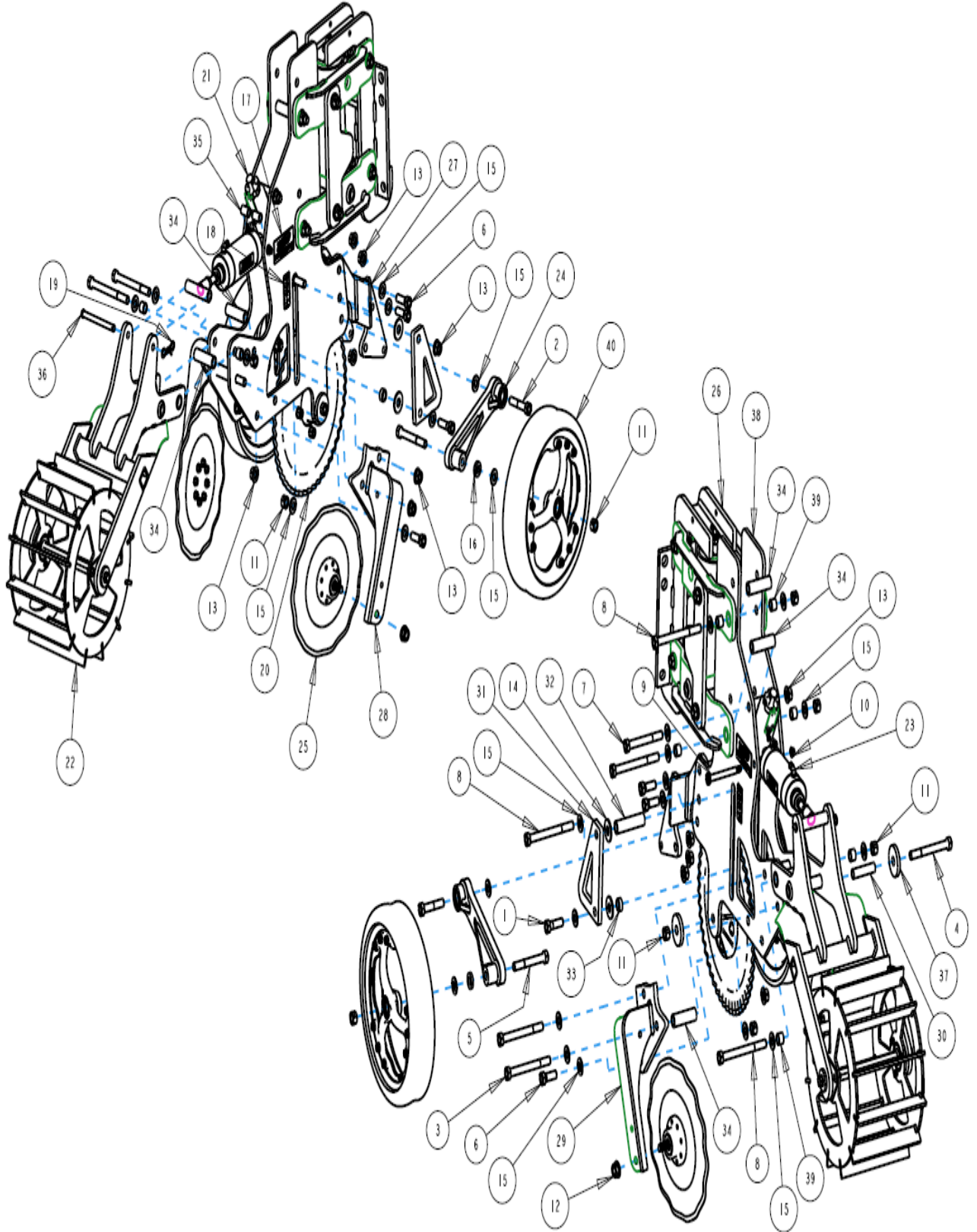

ISO2984-051B-R-SW

**PART IDENTIFICATION**  
**2984-051B-R-SW STRIP FRESHENER CC**

ITEM	PART NO.	DESCRIPTION	QTY
1	2502-322	5/8-11 x 2 HHCS GR 8	2
2	2502-330	5/8-11 X 3 HHCS GRADE 8 ZP	2
3	2502-352	5/8-11 X 6 HHCS GRADE 8 ZP	2
4	2502-384	5/8-11 X 5.5 HHCS GR8 ZP	1
5	2502-433	5/8-11 X 4-1/2 HHCS GR8 ZP	2
6	2502-440	5/8-11 X 1 3/4 HHCS GR8 ZP	6
7	2502-441	5/8-11 X 5 HHCS GR 8 ZP	1
8	2502-444	5/8-11 X 6-1/2" HHCS GR8 ZP	4
9	2510-312	1/2" DIA. X 4" L SHOULDER SCREW	1
10	2520-252	3/8-16 HEX FLANGE TOP LOCK NUT, GR G, ZP	1
11	2520-462	5/8-11 HEX LOCK NUT GR 8 ZP	8
12	2520-465	5/8-11 SER. FLANGE NUT, GR 8, ZP	2
13	2520-478	5/8-11 SER. FLNG NUT, GR 8, ZP W/THDLOCK	12
14	2526-451	5/8 STD FLATWASHER ZP	4
15	2526-454	5/8 SAE FLATWASHER HRD'ND ZP	24
16	2526-455	WASH 21/32" X 1 1/4" X 1/4	2
17	2565-356	STRIP FRESHENER DECAL	2
18	2565-836	ADJUSTMENT DECAL	2
19	2570-448	.120 BOWTIE LOCKING COTTER ZP	1
20	2984-143	RIPPLE BLADE ASSEMBLY	1
21	2984-144	DEPTH ADJUST ASSEMBLY	1
22	2984-146	ROLLING BASKET ASSEMBLY, 2984-050	1
23	2984-153	AIR CYLINDER ASSEMBLY	1
24	2984-157	GAUGE WHEEL ARM ASS'Y	2
25	2984-159	13 WAVE WHEEL ASSEMBLY	2
26	2984-160A	PARALLEL ARM ASSEMBLY, 7X7 & 7X9 TOOLBARS	1
27	2984-241	RM ARM MOUNT W.A.	1
28	2984-248A	R.H. SHARKTOOTH MOUNT W.A.	1
29	2984-249A	L.H. SHARKTOOTH MOUNT W.A.	1
30	2984-455	BEARING BORE ADAPTER, ZP	1
31	2984-468	DEPTH STOP	2
32	2984-469	TOP DEPTH STOP BUSHING	1
33	2984-470	DEPTH ADJ LOWER BUSHING	2
34	2984-479	CROSS BUSHING	5
35	2984-495	STRUT BUSHING SHORT	2
36	2984-497	AIR CYLINDER ROD PIN	1
37	2984-501	WASHER, .688ID X 2.50 OD X .375THK	2
38	2984-551	SIDE PLATE	2
39	2984-565	BUSHING, CHROME PLATED	6
40	6000-070	3" X 16" SPOKED GAUGE WHEEL (2023)	2

ISO2984-051B-R-SW

# PART IDENTIFICATION

## 2984-050E/2984-051B STRIP FRESHENER CC

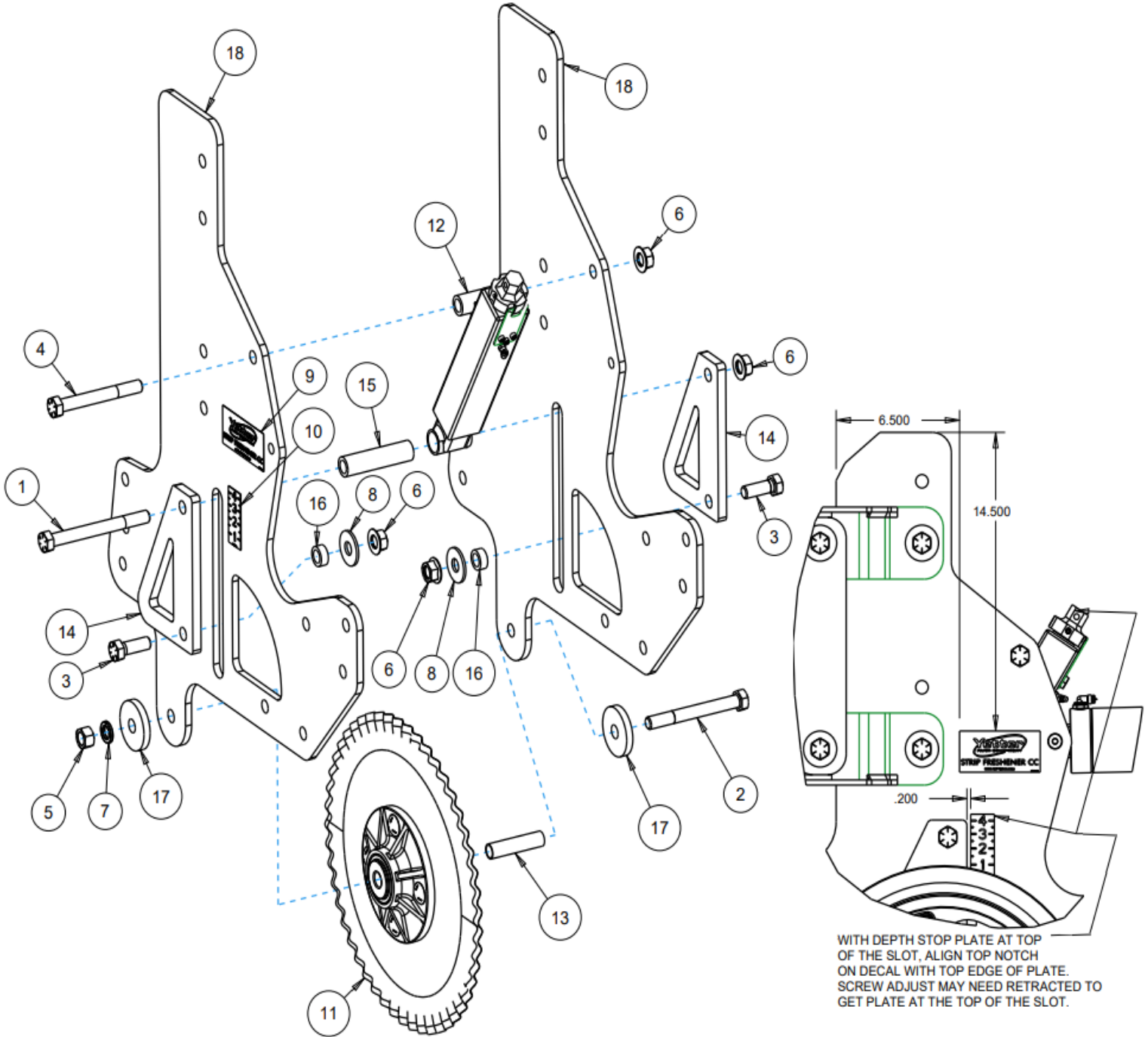

ITEM	PART #	DESCRIPTION	QTY
1	2502-322	5/8-11 X 2 HHCS GR 8	2
2	2502-384	5/8-11 X 5 1/2 HHCS GR 8	1
3	2502-441	5/8-11 X 5 HHCS GR 8	1
4	2502-444	5/8-11 x 6-1/2" HHCS GR8	4
5	2520-462	5/8-11 HEX NUT GR 8	8
6	2520-478	5/8-11 SER FLG NUT W/ THD LCK GR 8	12
7	2526-451	5/8 STD FLATWASHER	4
8	2526-454	5/8 SAE FLATWASHER HRD'D	24
9	2565-356	STRIP FRESHENER DECAL	2
10	2565-836	ADJUSTMENT DECAL	2
11	2984-143	RIPPLE BLADE ASSEMBLY	1
12	2984-144	DEPTH ADJUST ASSEMBLY	1
13	2984-455	BEARING BORE ADAPTER ZP	1
14	2984-468	DEPTH STOP	2
15	2984-469	TOP DEPTH STOP BUSHING	1
16	2984-470	DEPTH ADJUSTMENT LOWER BUSHING	2
17	2984-501	WASHER, .688ID X 2.500D X .375THK	2
18	2984-551	SIDE PLATE	2

## PART IDENTIFICATION PIVOT HARDWARE

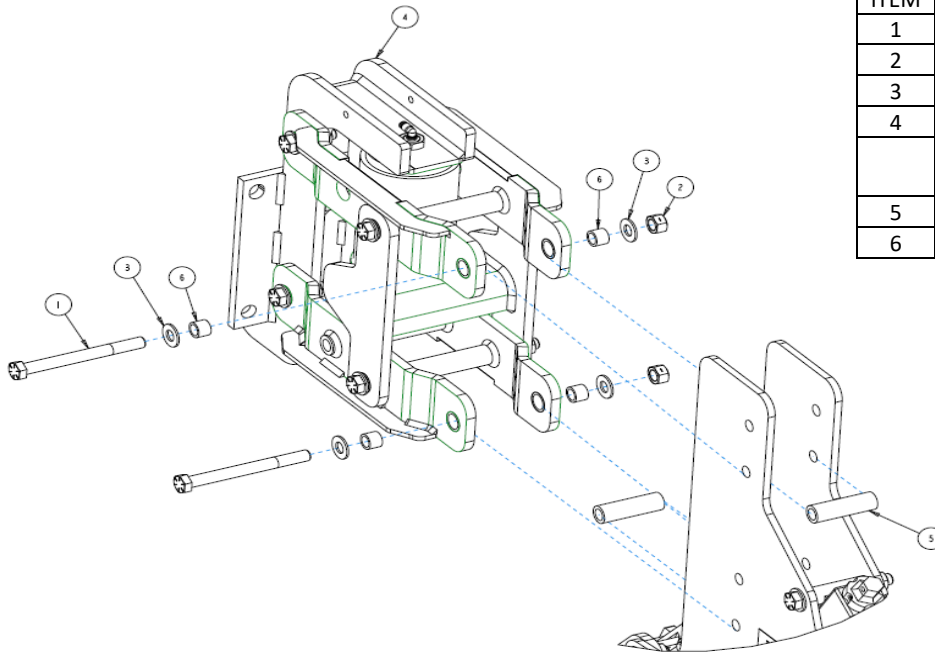

ITEM	PART #	DESCRIPTION	QTY
1	2502-444	5/8-11 X 6-1/2 HHCS GR 8	4
2	2520-462	5/8-11 HEX LOCK NUT GR 8	8
3	2526-454	5/8 SAE FLATWASHER HRD'ND	24
4	2984-158A	PARALLEL ARM ASSEMBLY	1
	*2984-160A	PARALLEL ARM ASSEMBLY 7X7/7X9	1
5	2984-479	CROSS BUSHING	5
6	2984-565	BUSHING CHROME	6

## 2984-158A/160A PARALLEL LINKAGE ASSEMBLY PART IDENTIFICATION

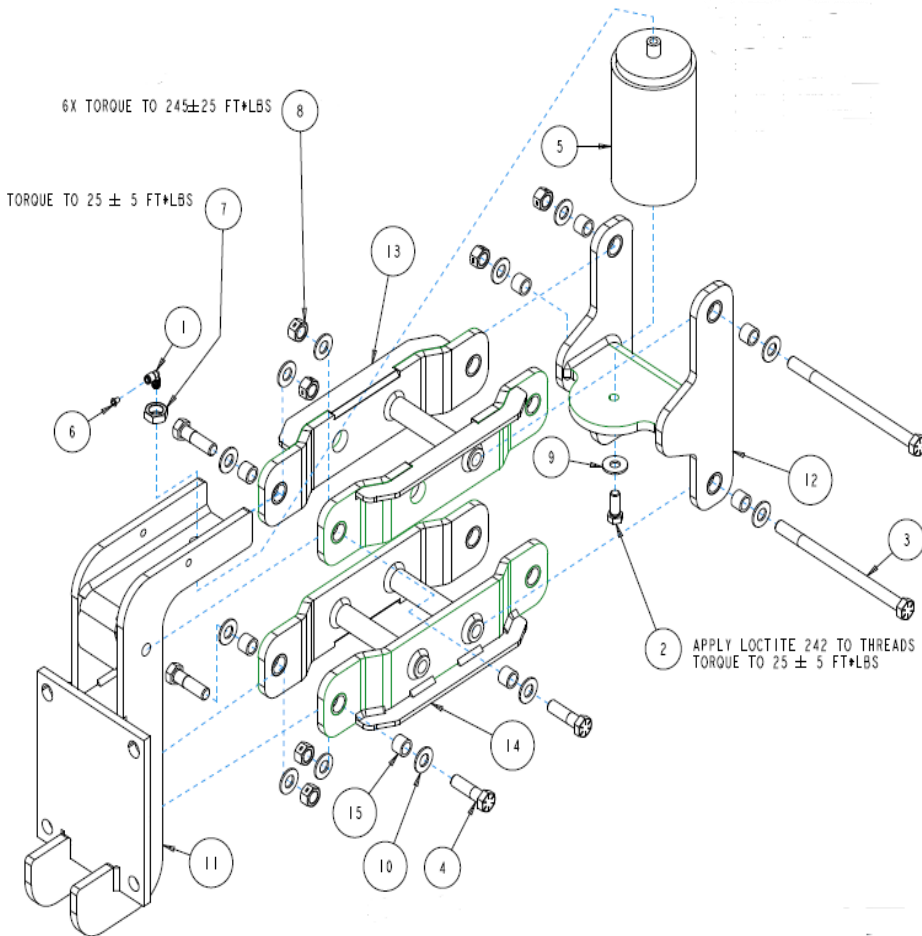

ITEM	PART #	DESCRIPTION	QTY
1	1200-323	¼ TUBE TO 1/8NPT ELBOW FITTING	1
2	2502-293	½-13 X 1 ¼ HHCS GR 5	1
3	2502-445	5/8-11 X 9.5" HHCS GR 8	2
4	2502-823	5/8-11 X 2-1/4" HHCS GR 8	4
5	2515-304	AIR BAG	1
6	2515-856	¼" AIR FITTING PLUG	1
7	2520-312	¾'16 JAM HEX NUT	1
8	2520-462	5/8-11 HEX LOCK NUT GR 8	4
9	2526-351	½ STD FLATWASHER	1
10	2526-454	5/8 SAE FLATWASHER HRD'ND	12
11	*2984-242	TOOLBAR MOUNT	1
	2984-266	7X7/7X9 TOOLBAR MOUNT	1
12	2984-262A	AIR BAG BASE WELDMENT	1
	2984-500	PIVOT SLEEVE	4
13	2984-263A	UPPER PARALLEL ARM	1
	2984-500	PIVOT SLEEVE	4
14	2984-264A	LOWER PARALLEL ARM	1
	2984-500	PIVOT SLEEVE	4
15	2984-565	9/16" BUSHING CHROME PLATED	8

\*INDICATES ASSEMBLY THAT IS SHOWN

## 2984-241 RM ARM MOUNT PART ID

ITEM	PART #	DESCRIPTION	QTY
1	2502-440	5/8-11 X 1-3/4" HHCS GR 8	6
2	2520-478	5/8-11 HEX FLANGE LOCK NUT GR 8	12
3	2526-454	5/8 SAE FLATWASHER HRD'ND	24
4	2984-241	RESIDUE MANAGER MOUNT	1

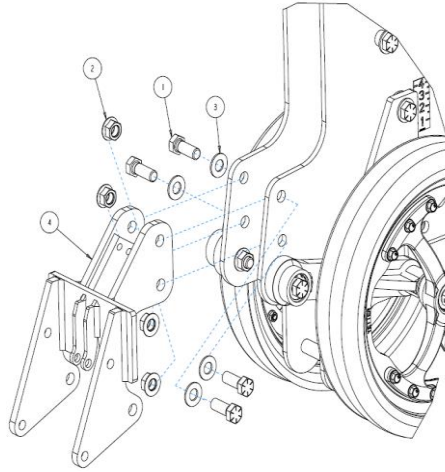

## 2984-090A-NR ROW CLEANER ASSEMBLY PART ID

2984-154A INCLUDES:

- 1) 2529-511, 1) 2529-512,
- 2) 2531-107, & 1) 2940-650

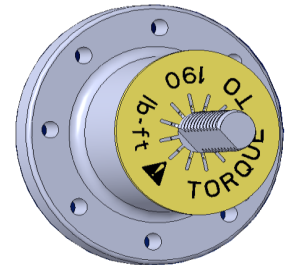
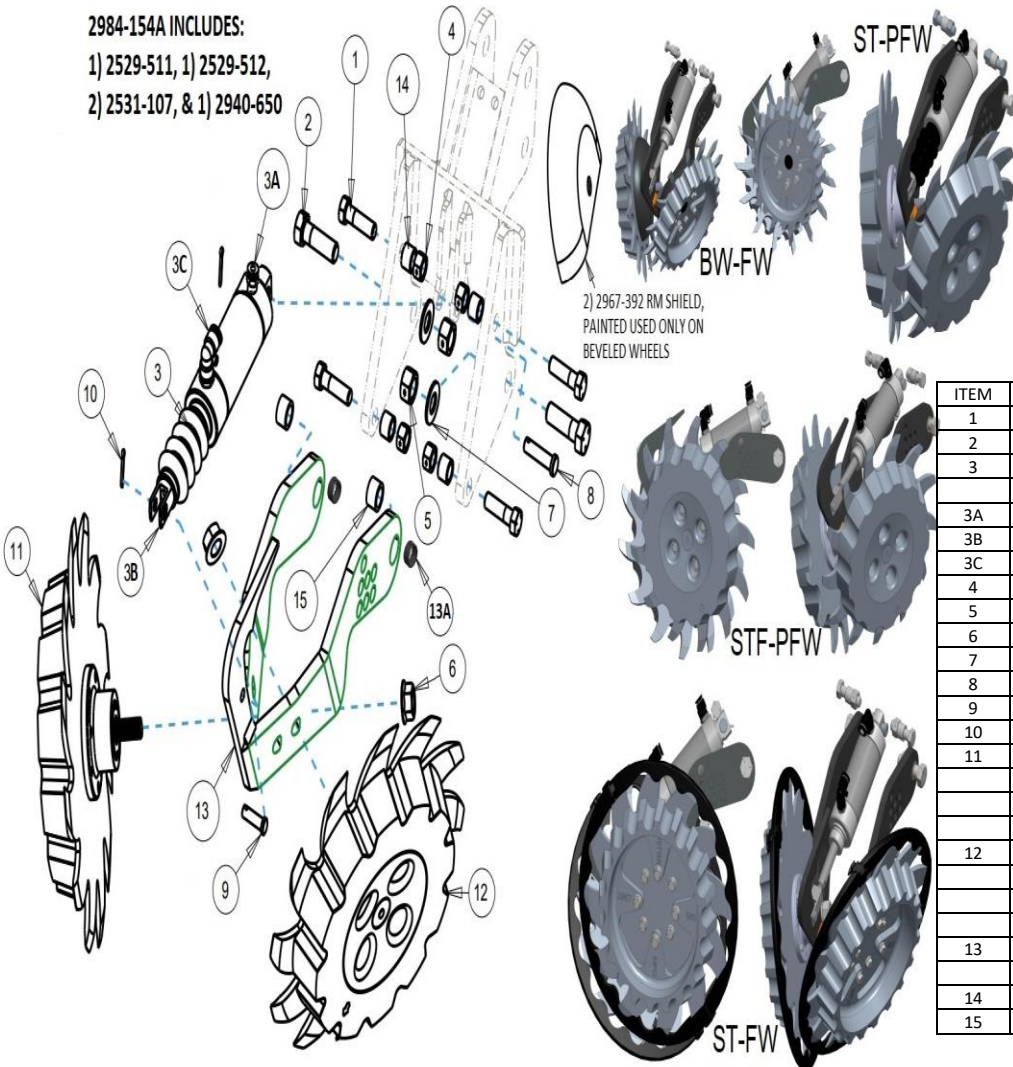

**Torque to 190ft/lbs**

ITEM	PART #	DESCRIPTION	QTY
1	2502-317	½-13 X 1 ¾ HHCS GR 5 ZP	4
2	2502-391	5/8-11 X 2 HHCS GR 5 ZP	2
3	2515-305A	AIR ASSIST CYLINDER ASSEMBLY	1
	2515-082	AIR ASSIST CYLINDER SEAL KIT	
3A	2515-916	1/4PC X 1/4NPT STRAIGHT, BRSS NKL	1
3B	2515-917	AIR CYLINDER CLEVIS	1
3C	2940-650	1/4PC X 1/4NPT ELBOW, BRSS NKL	1
4	2520-357	½-13 LOCK HEX NUT GR A ZP	4
5	2520-459	5/8-11 LOCK HEX NUT GR B ZP	2
6	2520-465	5/8-11 SERRATED FLG NUT GR 8 ZP	2
7	2526-453	5/8 SAE FLATWASHER ZP	2
8	2529-511	CAP PIN, AIR ASSIST CYLINDER	1
9	2529-512	CLEVIS PIN, AIR ASSIST CYLINDER	1
10	2531-107	1/8 X 1 COTTER PIN ZP	2
11	2966-140-BW-FW	RH BEVEL W/ FLTR WHL, 3" D BLT	1
	2966-140-STFW	RH SHKTTH W/ FLTR WHL, 3" D BLT	1
	2966-140-ST-PFW	RH SHKTTH W/ PLY FLTR, 3" D BLT	1
	2966-140-STF-FW	RH SHKTTH FNGR W/ PLY FLTR, 3" D BLT	1
12	2966-141-BW-FW	LH BEVEL W/ FLTR WHL, 3" D BLT	1
	2966-141-STFW	LH SHKTTH W/ FLTR WHL, 3" D BLT	1
	2966-141-ST-PFW	LH SHKTTH W/ PLY FLTR, 3" D BLT	1
	2966-141-STF-FW	LH SHKTTH FNGR W/ PLY FLTR, 3" D BLT	1
13	2966-291	ARM. NARROW TITAN	1
	6000-560	SPLIT TENSION BUSHING	2
14	2967-622	9/16 SPACER ZP	4
15	600-335	9/16 BUSHING	2

# 2984-090A-W ROW CLEANER ASSEMBLY PART IDENTIFICATION

2984-154A INCLUDES:  
ITEM 3C, 10 (2),  
8, & 9

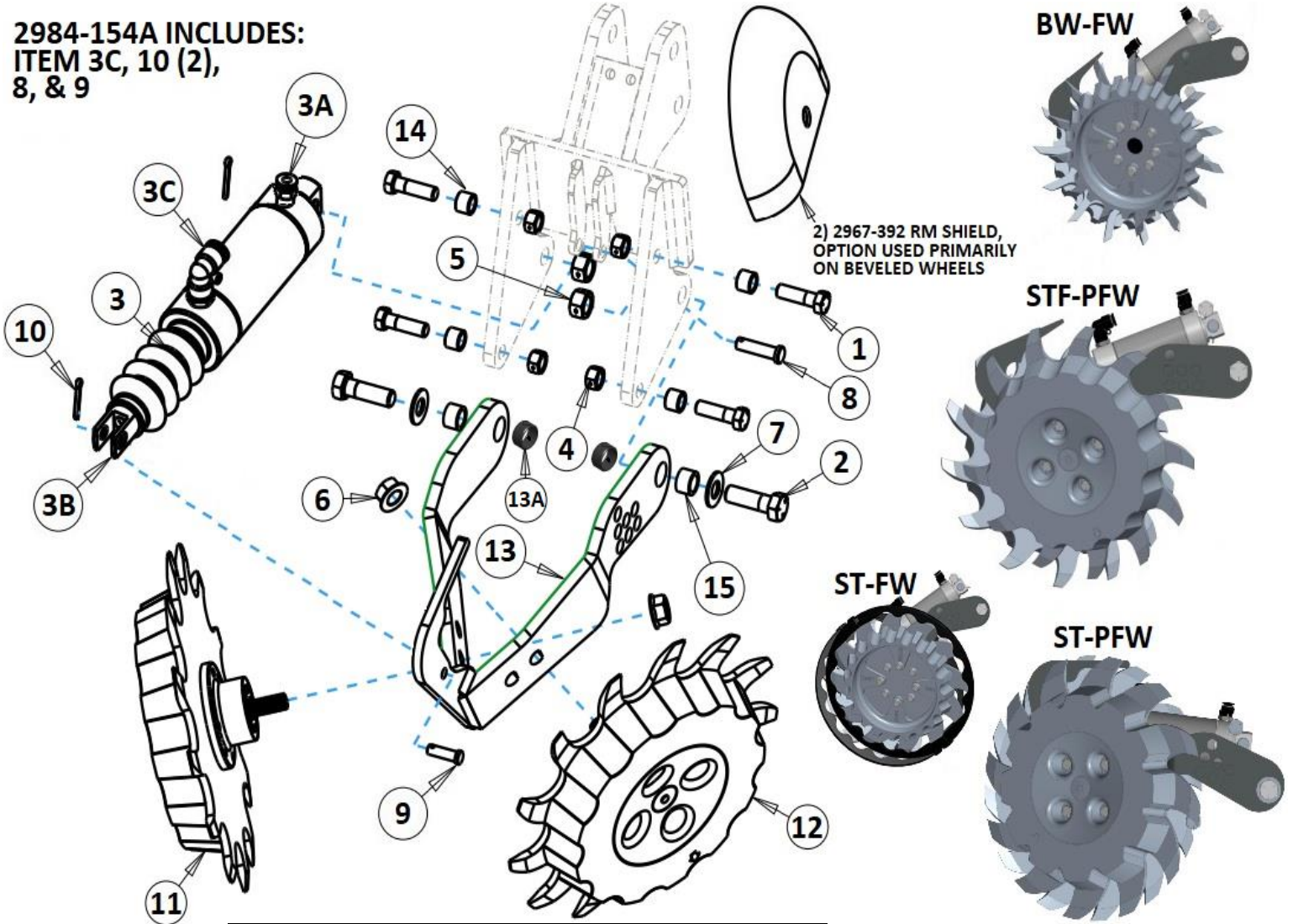

ITEM	PART #	DESCRIPTION	QTY
1	2502-317	½-13 X 1 ¼ HHCS GR 5 ZP	4
2	2502-391	5/8-11 X 2 HHCS GR 5 ZP	2
3	2515-305A	AIR ASSIST CYLINDER ASSEMBLY	1
	2515-082	AIR ASSIST CYLINDER SEAL KIT	
3A	2515-916	1/4PC X 1/4NPT STRAIGHT, BRSS NKL	1
3B	2515-917	AIR CYLINDER CLEVIS	1
3C	2940-650	1/4PC X 1/4NPT ELBOW, BRSS NKL	1
4	2520-357	½-13 LOCK HEX NUT GR A ZP	4
5	2520-459	5/8-11 LOCK HEX NUT GR B ZP	2
6	2520-465	5/8-11 SERRATED FLG NUT GR 8 ZP	2
7	2526-453	5/8 SAE FLATWASHER ZP	2
8	2529-511	CAP PIN, AIR ASSIST CYLINDER	1
9	2529-512	CLEVIS PIN, AIR ASSIST CYLINDER	1
10	2531-107	1/8 X 1 COTTER PIN ZP	2
11	2966-140-BW-FW	RH BEVEL W/ FLTR WHL, 3" D BLT	1
	2966-140-STFW	RH SHKTTH W/ FLTR WHL, 3" D BLT	1
	2966-140-ST-PFW	RH SHKTTH W/ PLY FLTR, 3" D BLT	1
	2966-140-STF-FW	RH SHKTTH FNGR W/ PLY FLTR, 3" D BLT	1
12	2966-141-BW-FW	LH BEVEL W/ FLTR WHL, 3" D BLT	1
	2966-141-STFW	LH SHKTTH W/ FLTR WHL, 3" D BLT	1
	2966-141-ST-PFW	LH SHKTTH W/ PLY FLTR, 3" D BLT	1
	2966-141-STF-FW	LH SHKTTH FNGR W/ PLY FLTR, 3" D BLT	1
13	2966-292	ARM. WIDE TITAN	1
13A	6000-560	SPLIT TENSION BUSHING	2
14	2967-622	9/16 SPACER ZP	4
15	600-335	9/16 BUSHING	2

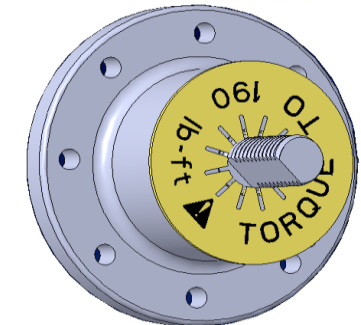

**Torque to 190ft/lbs**

## GAUGE WHEEL ASSEMBLY PARTS IDENTIFICATION

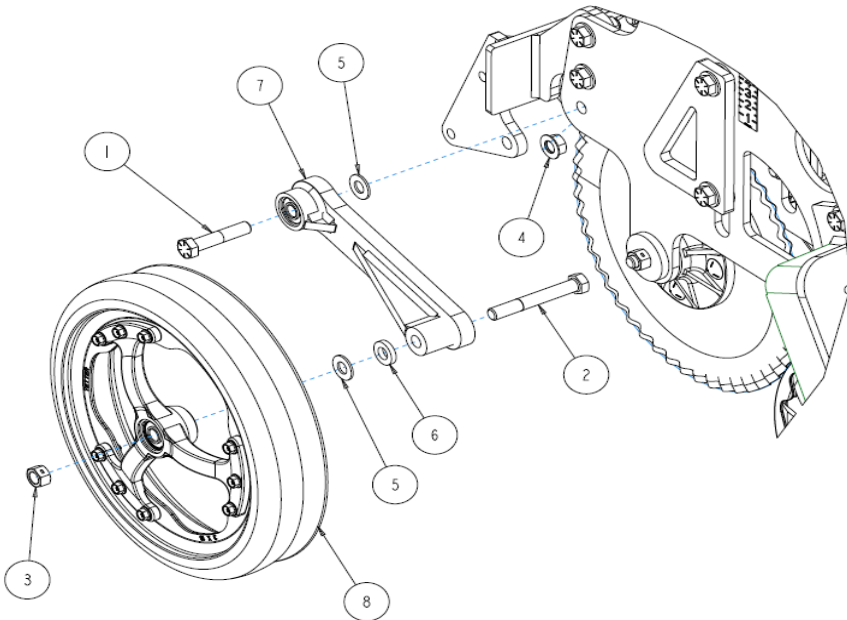

ITEM	PART #	DESCRIPTION	QTY
1	2502-330	5/8-11 X 3 HHCS GR 8	2
2	2502-433	5/8-11 X 4 1/2 HHCS GR 8	2
3	2520-462	5/8-11 HEX LOCK NUT GR 8	2
4	2520-478	5/8-11 SER FLG NUT GR 8 ZP W/ THRD LK	2
5	2526-454	5/8 SAE FLAT WASHER HRD'ND	4
6	2526-455	WASHER 21/32" X 1-1/4" X 1/4"	2
7	2984-157	GAUGE WHEEL ARM ASSEMBLY	2
	2550-526	SNAP RING	2
	2570-069	BEARING	2
8	6000-070	3" X 16" SPOKED GAUGE WHEEL	2
	2570-069	BEARING	2

## BERMING DISC ASSEMBLY PART IDENTIFICATION

ITEM	PART #	DESCRIPTION	QTY
1	2502-352	5/8-11 X 6 HHCS GR 8 ZP	2
2	2502-440	5/8-11 X 1 3/4 HHCS GR 8 ZP	2
3	2520-465	5/8-11 SER FLG NUT GR 8 ZP	2
4	2520-478	5/8-11 SER FLG NUT GR 8 ZP W/ THRD LK	4
5	2526-454	5/8 SAE FLATWASHER HRD'ND	4
6	2966-140-ST	RH SHKTTH WHL ASSEMBLY, 3" D BOLT	1
6A	2984-159	13 WAVE WHEEL ASSEMBLY	2
7	2966-141-ST	LH SHKTTH WHL ASSEMBLY, 3" D BOLT	1
8	2984-248A	RH WHEEL MOUNT	1
9	2984-249A	LH WHEEL MOUNT	1
10	2984-479	CROSS BUSHING	2

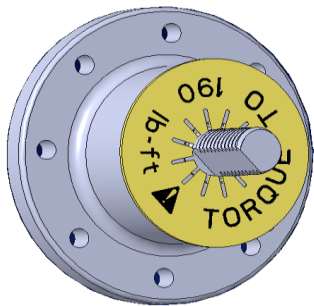
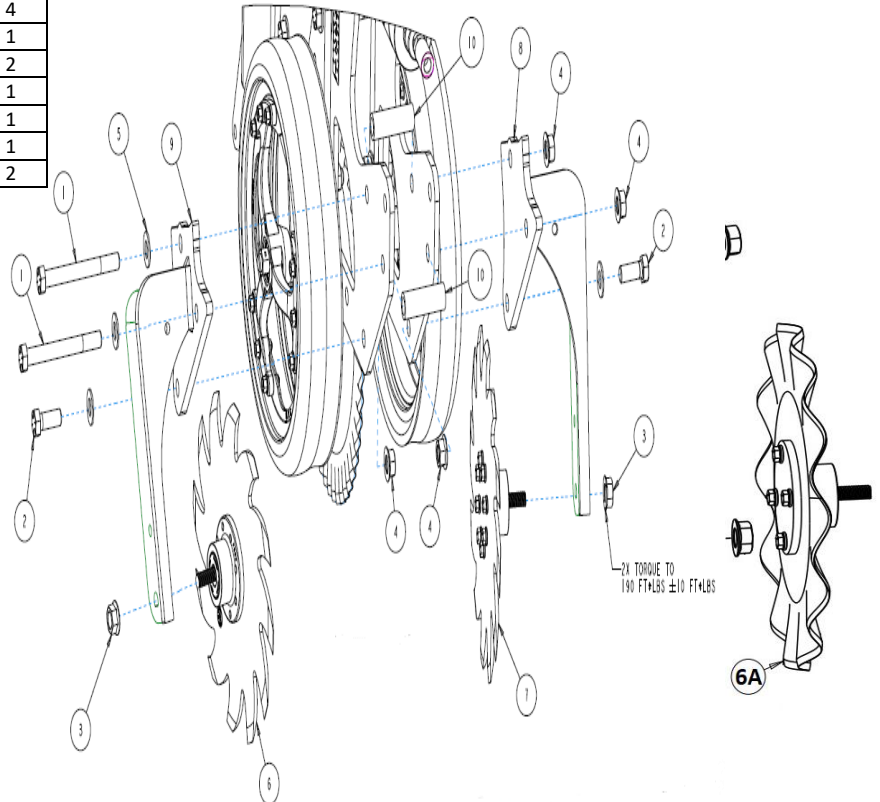

**Torque to 190ft/lbs**

# ROLLING BASKET ASSEMBLY PART ID

ITEM	PART #	DESCRIPTION	QTY
1	2515-306A	3"BORE X 3" STROKE AIR CYLINDER	1
2	2515-307	90 DEG SW ELBOW, 1/4" TUBE X 3/8NPTM	2
3	2515-856	1/4" AIR FITTING PLUG	2
4	2520-460	5/8-18 JAM HEX NUT ZP	1
5	2984-265	CYLINDER CLEVIS W.A.	1

## 2984-153 AIR CYLINDER ASSEMBLY PART ID

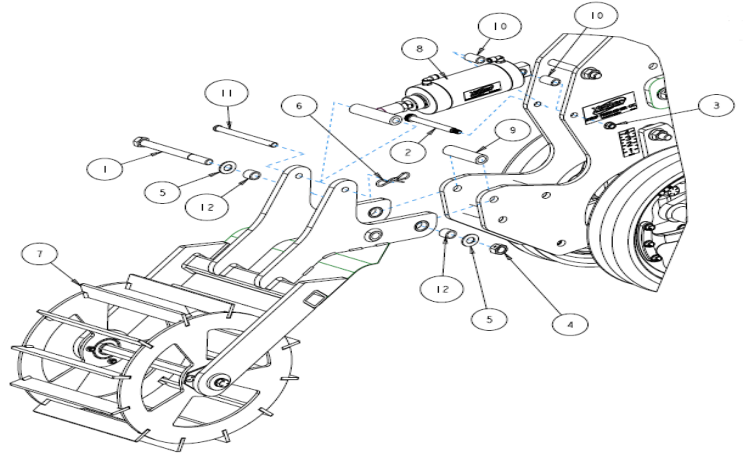
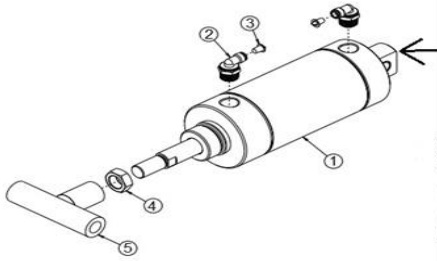

1	2502-444	5/8-11 X 6-1/2" HHCS GR 8	1
2	2510-312	1/2" DIA. X 4" L SHOULDER SCREW	1
3	2520-252	3/8-16 HEX FLG TOP LOCK NUT GR G	1
4	2520-462	5/8-11 HEX LOCK NUT GR 8	1
5	2526-454	5/8 SAE FLATWASHER HRD'ND	2
6	2570-448	.120 BOWTIE LOCKING COTTER ZP	1
7	2984-146	ROLLING BASKET ASSEMBLY	1
8	2984-153	AIR CYLINDER ASSEMBLY	1
9	2984-479	CROSSING BUSHING	2
10	2984-495	STRUT BUSHING SHORT	2
11	2984-497	AIR CYLINDER ROD PIN	1
12	2984-565	BUSHING CHROME	2

## 2984-146 ROLLING BASKET ASSEMBLY

ITEM	PART #	DESCRIPTION	QTY
1	2502-294	1/2-13 X 1 1/2 JJCS GR 5 ZP	2
2	2505-205	5/16-18 X 3/4 CAR BOLT GR 5 ZP	6
3	2520-205	5/16-18 LOCK HEX NUT GR A ZP	6
4	2525-352	1/2 MED LOCK WASHER ZP	2
5	2526-402	9/16ID X 1 3/4 OD X 1/4MB ZP	2
6	2550-338	BEARING ONLY	2
7	2570-787	FLANGED BEARING ASSEMBLY, 7/8" HEX	2
8	2940-634	HEX SHAFT	1
9	2984-250	ROLLING BASKET MOUNT W.A.	1
10	2984-251	ROLLING BASKET W.A.	1

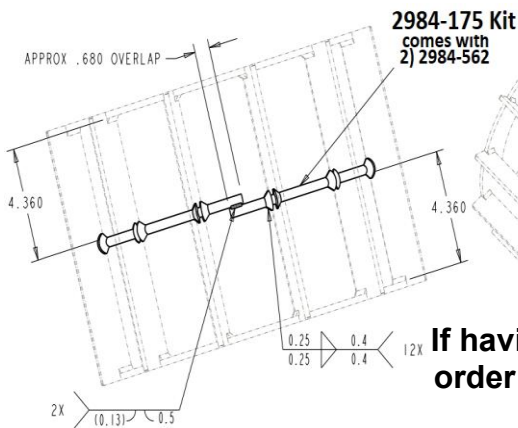

2984-175 Kit  
comes with  
2) 2984-562

**If having issues with rocks,  
order 1) 2984-175 per row**

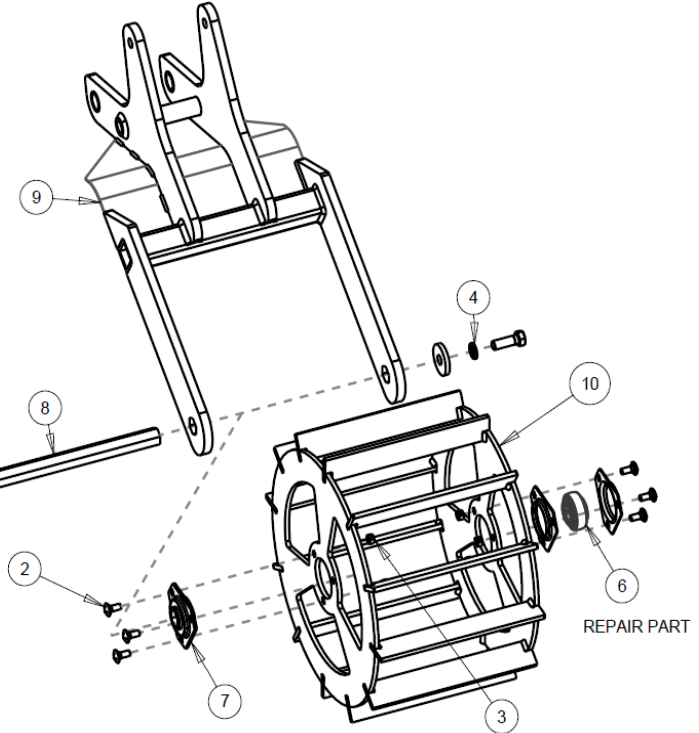

REPAIR PART

# WHEEL ASSEMBLY & HUB/BEARING PART IDENTIFICATION

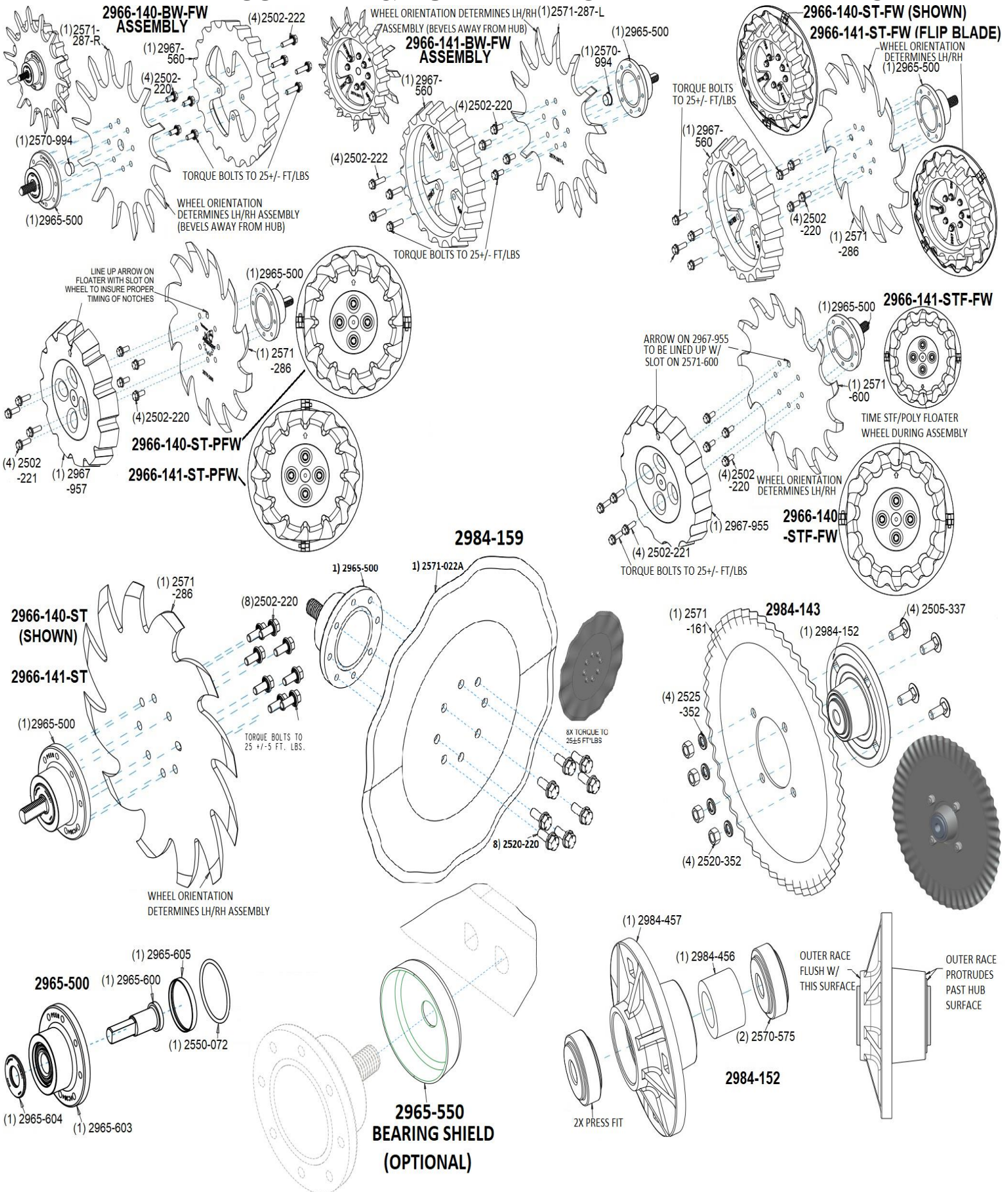

## SCREW ADJUST ASSEMBLY PART IDENTIFICATION

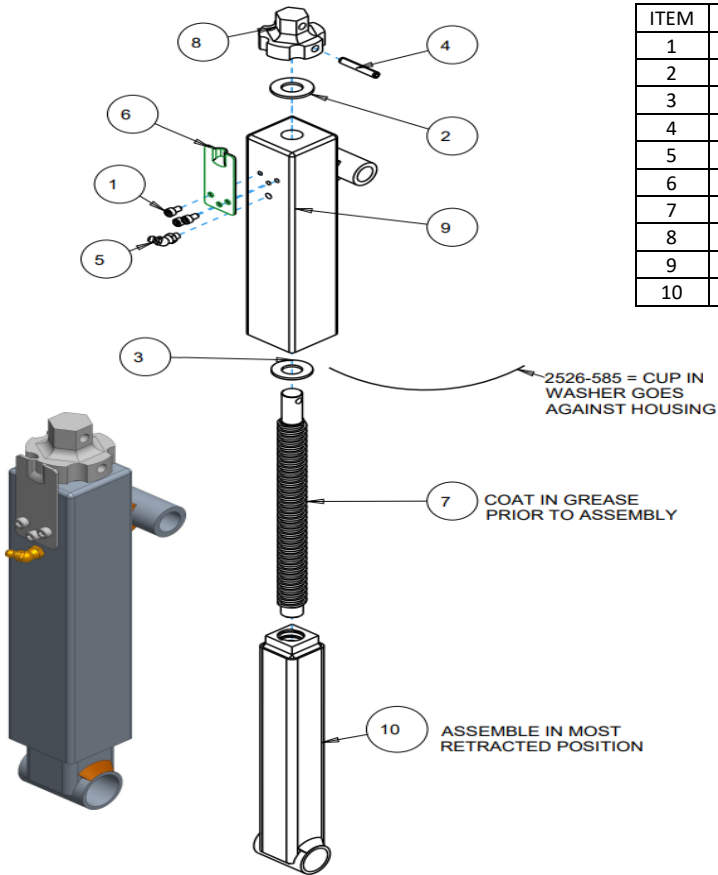

ITEM	PART #	DESCRIPTION	QTY
1	2510-102	#10-32 X .31 HSHCPS ZP W/ THRD LCK	3
2	2526-453	5/8 SAE FLATWASHER ZP	1
3	2526-585	DISC SPRING	1
4	2530-158	PIN, COILED SPRING, 1/4 X 1 1/2 HD	1
5	2533-111	1/4-28 45 DEGREE GREASE ZERK, SELF TAPPED	
6	2967-652	DETENT PLATE ZP	1
7	2967-657	ACME SCREW	1
8	2967-699	ADJUSTMENT KNOB	1
9	2984-245	DEPTH ADJUSTMENT HOUSING	1
10	2984-246	INNER TUBE W.A.	1

## FERTILIZER TUBE ASSEMBLY PART IDENTIFICATION

2984-083A LIQUID KIT LEFT

2984-082A LIQUID KIT RIGHT

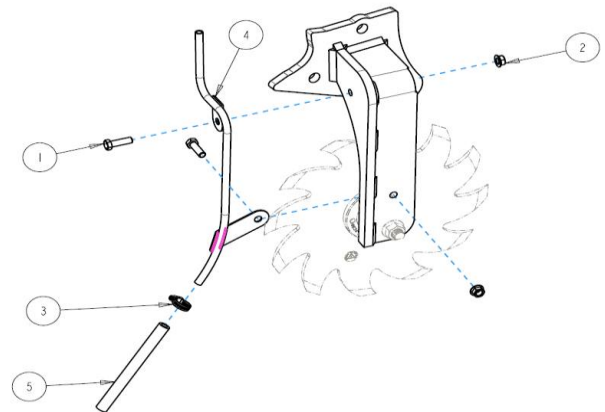
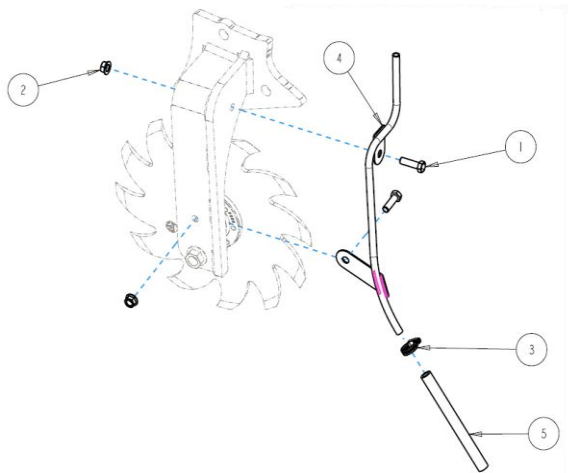

ITEM	PART #	DESCRIPTION	QTY
1	2502-244	3/8-16 X 1-1/4 HHCS GR 5	4
2	2520-252	3/8-16 HEX FLANGE TOP LOCK GR G	4
3	2570-718	HOSE CLAMP	2
4	2984-253A	LH FERTILIZER TUBE	1
	2984-254A	RH FERTILIZER TUBE	1
5	2984-518	DISCHARGE HOSE	2

# FERTILIZER TUBE ASSEMBLY PARTS IDENTIFICATION

2984-084 - CENTER LIQUID FERTILIZER KIT ASSEMBLY

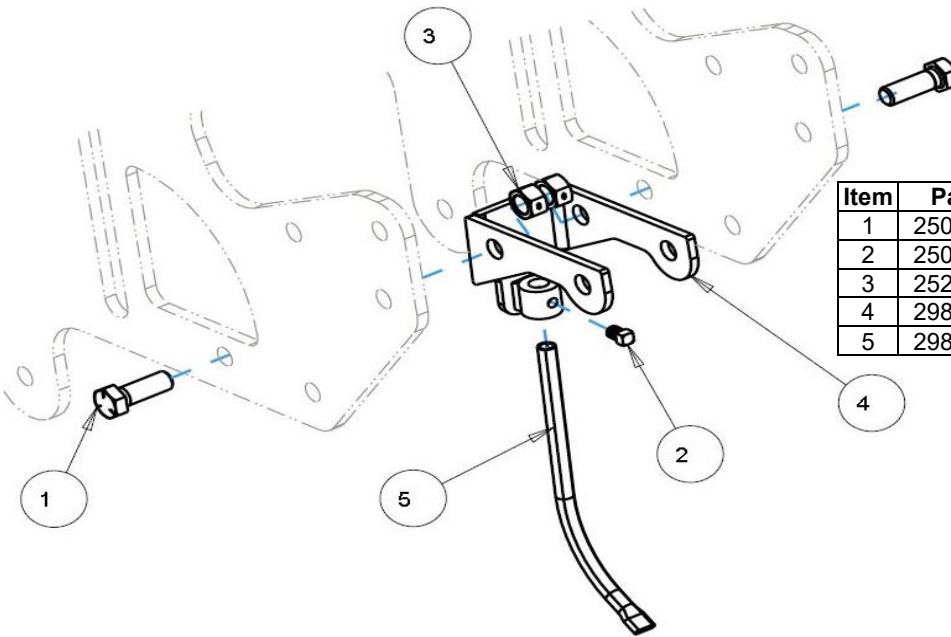

Item	Part #	Description	Qty
1	2502-331	5/8-11 X 1 3/4 HHCS GR 5 ZP	2
2	2503-256	3/8-16 X 1/2 SQ HCPSS GR 5 SS	1
3	2520-459	5/8-11 LOCK HEX NUT GR 8 ZP	2
4	2984-252	CENTER FERT MOUNT W.A.	1
5	2984-446	STRIP FRESHENER LIQ TUBE	1

## 2984-085-L CENTER DRY FERT KIT ASSEMBLY, LH

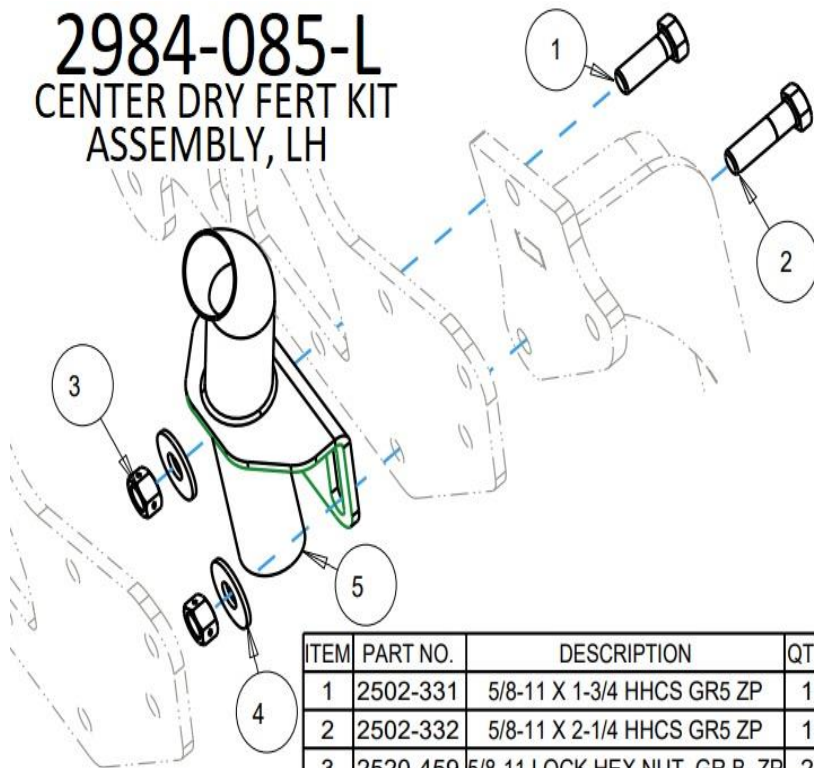

ITEM	PART NO.	DESCRIPTION	QTY
1	2502-331	5/8-11 X 1-3/4 HHCS GR5 ZP	1
2	2502-332	5/8-11 X 2-1/4 HHCS GR5 ZP	1
3	2520-459	5/8-11 LOCK HEX NUT, GR B, ZP	2
4	2526-451	5/8 STD FLATWASHER ZP	2
5	2984-255	CENTER FERT MOUNT WA, LH	1
6	2984-260	CENTER FERT MOUNT WA, RH	1

## 2984-085-R CENTER DRY FERT KIT ASSEMBLY, RH

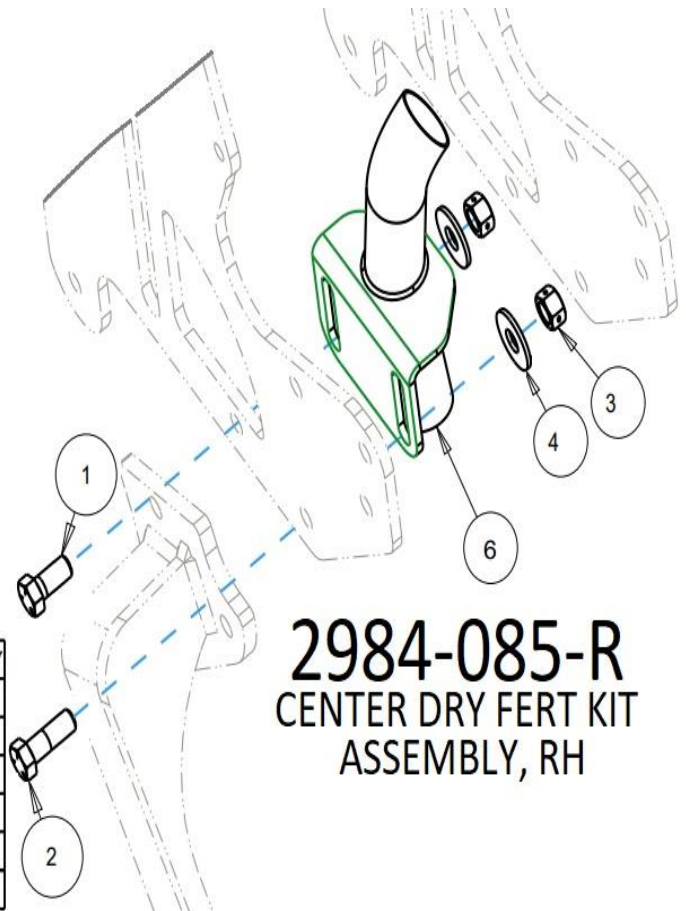

# 2984-156 CONTROL BOX PARTS IDENTIFICATION

ITEM	PART #	DESCRIPTION	QTY
1	2565-357	CONTROL BOX DECAL	1
2	2984-520	RAM-2461U VESA PLATE ADAPTER	1
3	2984-523	ELBOW FITTING, PLF-532-N01U	2
4	2984-524	358-910 PUSH PULL VALVE	1
5	2984-525	358-910 TOP SELECTOR VALVE	1
6	2984-526	CONTROL BOX ENCLOSURE W/ LID	1
7	2984-527	HAA51737 GAUGE SHUTTLE	2
8	2984-528	PANEL MOUNT GAUGE, 0-100PSI	1
9	2984-529	REGULATOR ASSEMBLY	5
10	2984-530	PANEL MOUNT GAUGE, 0-160PSI	1
11	2984-542	BULKHEAD FITTING, 3/8"PC X M14 X 1 STRT	6
12	2984-545	SWITCH	1
13	2984-546	DEUTSCH HOUSING FOR MALE TERM.	2
14	2984-550	ROW LOCK MANUAL ADJUST	1

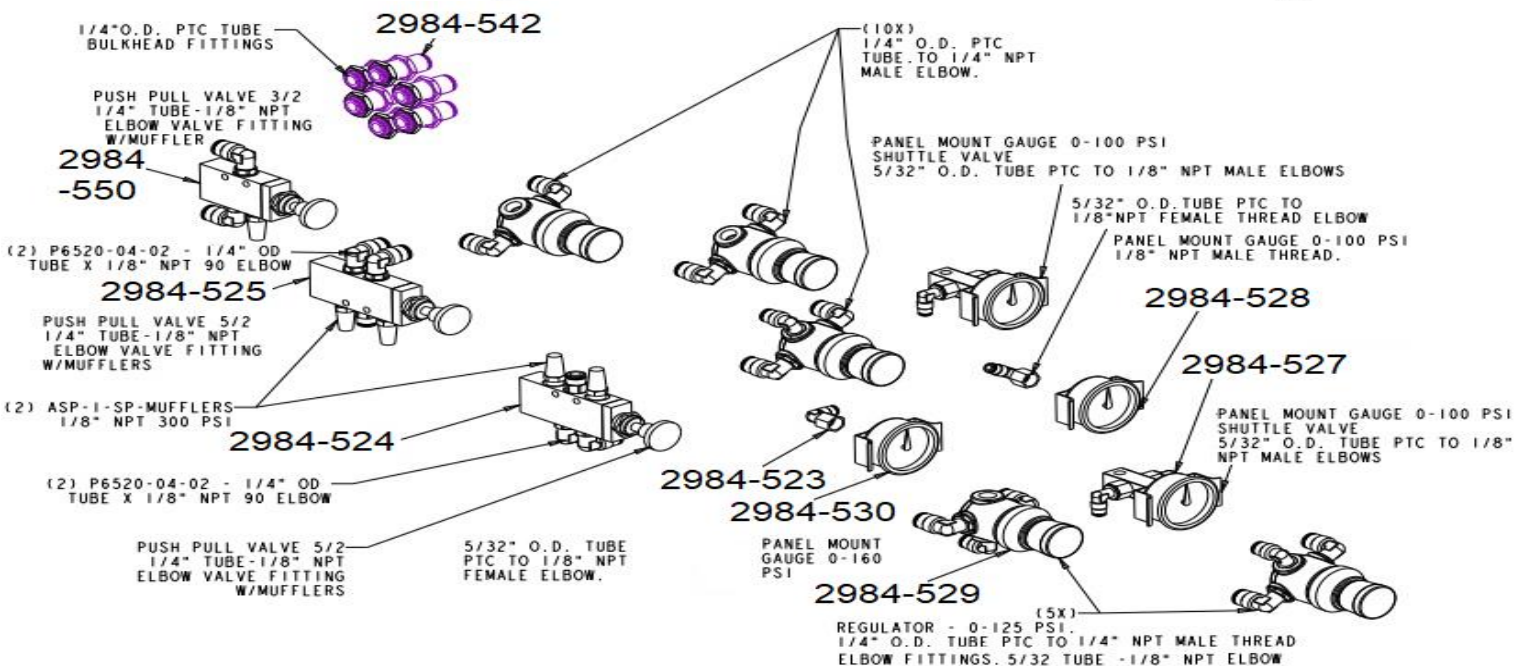
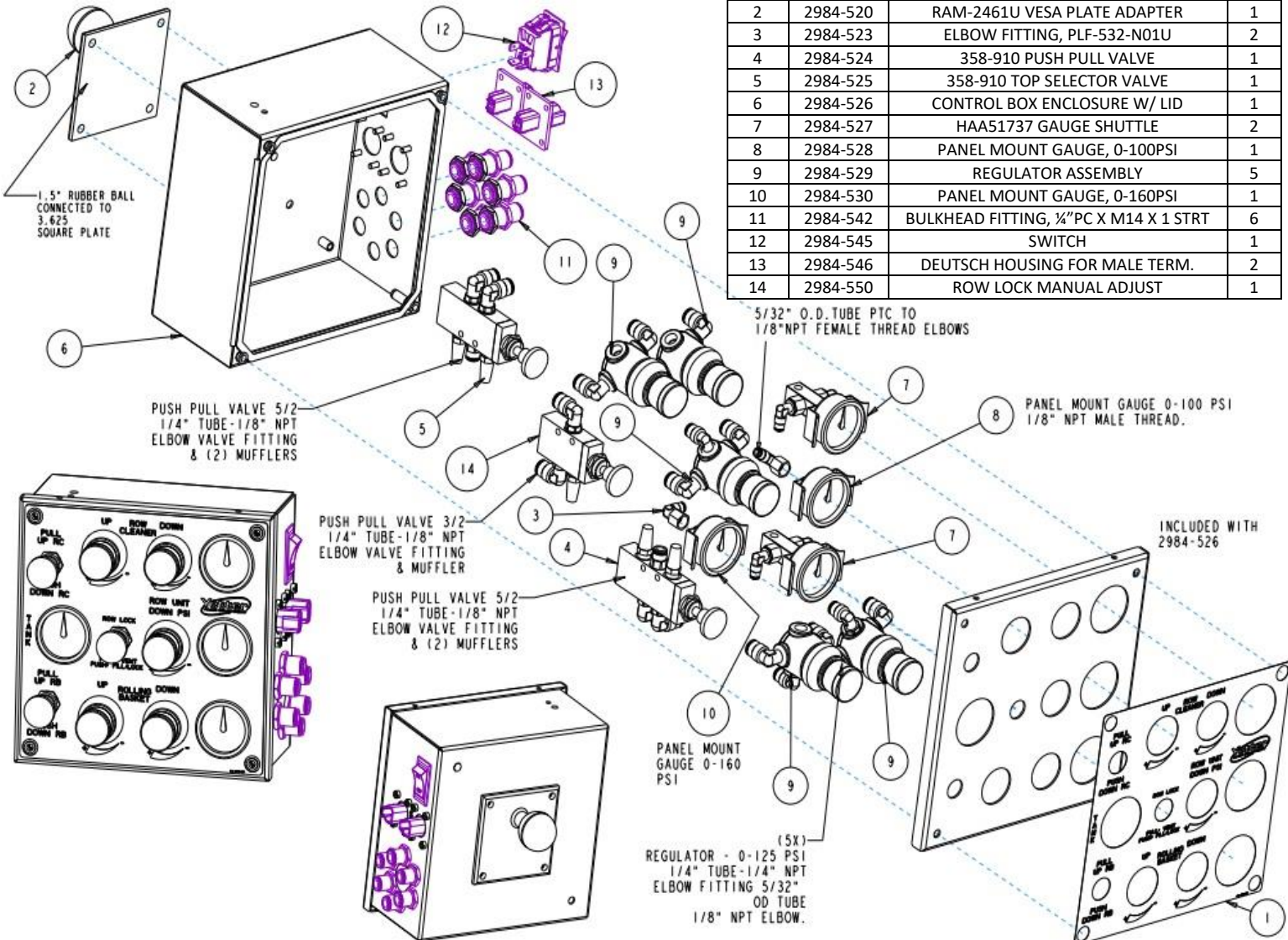

# PARTS IDENTIFICATION

## 2984-071 AUXILIARY DOWN PRESSURE REGULATOR KIT

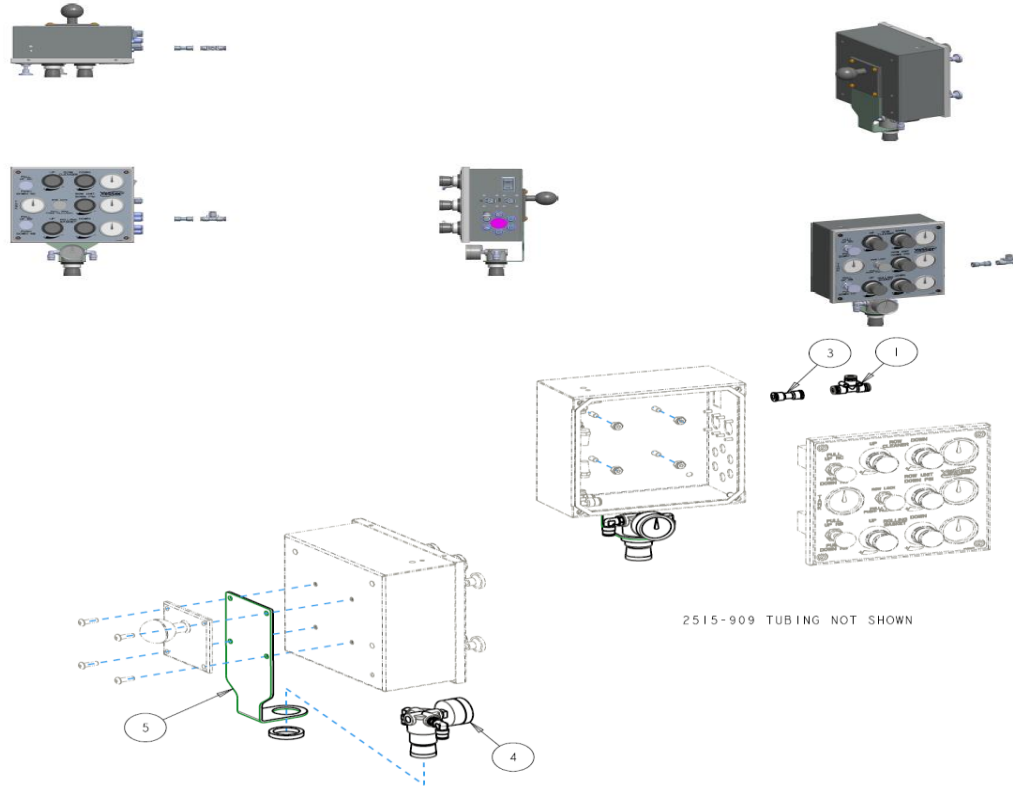

1SO2984-071

ITEM	PART NO.	DESCRIPTION	QTY
1	2515-905	1/4" PUSH IN UNION TEE	1
2	2515-909	ORANGE 1/4" NYLON TUBING, 100' ROLL	1
3	2515-911	1/4" PUSH IN STRAIGHT UNION CONNECTOR	1
4	2984-156	CONTROL BOX, STRIP FRESHENER CC	1
5	2984-571	REGULATOR BRACKET	1

### 8 BOLT HUB ASSEMBLY

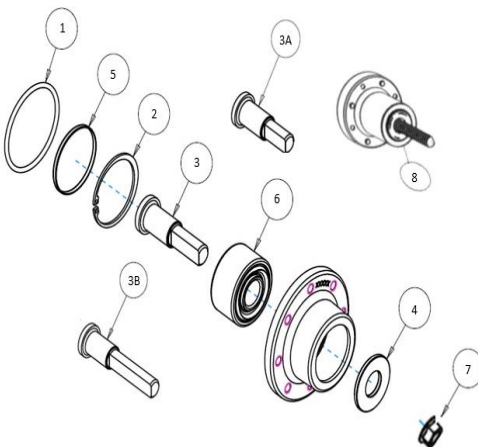

ITEM	PART #	DESCRIPTION	QTY
1	2550-074	O-RING 3.55MM X 56MM ID	1
2	2550-529	SNAP RING	1
3	2965-600A	SHAFT 73 MM (2965-500A HUB ASSEMBLY)	1
3A	2965-602A	SHAFT 66.7 MM (2965-502A HUB ASSEMBLY)	1
3B	2965-601A	SHAFT 98.4 MM (2965-501A HUB ASSEMBLY)	1
4	2965-604A	SPACER	1
5	2965-605A	CAP	1
6	2965-606	BEARING	1
7	2520-465	5/8-11 FLANGE HEX NUT GRADE 8	1
8	2965-500A	HUB ASSEMBLY 1.406" SPINDLE	1
	2965-501A	HUB ASSEMBLY 2.406" SPINDLE	1
	2965-502A	HUB ASSEMBLY 1.157" SPINDLE	1

# 2940-106 HYD COMP PARTS IDENTIFICATION

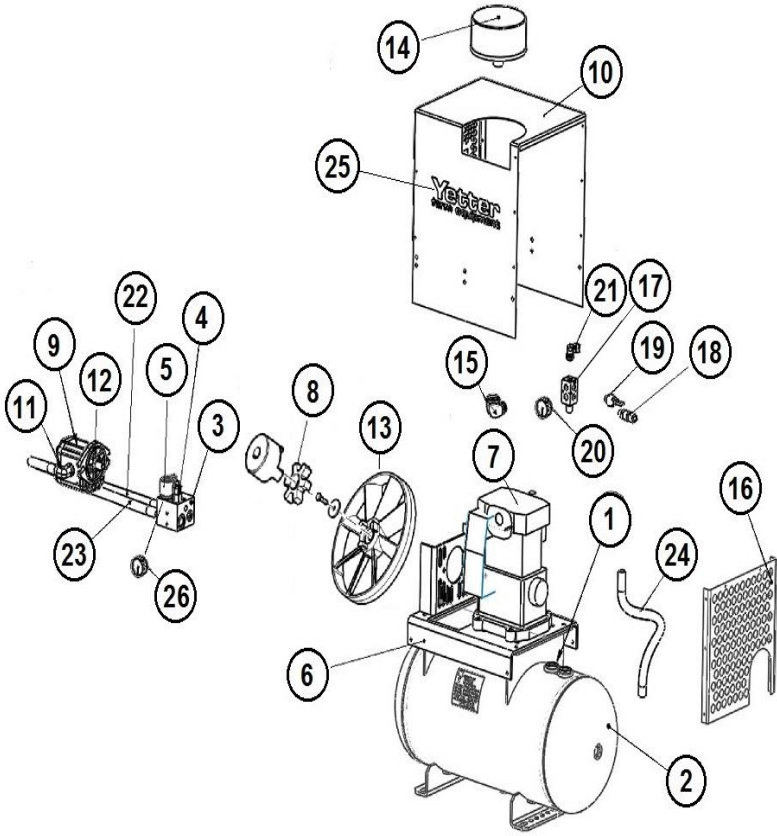

Item	Part #	Description	Qty
1	N/A	CHECK VALVE	1
2	2940-440	12 GALLON TANK	1
3	2940-546	HYDRAULIC COMPRESSOR CONTROL BLOCK	1
4	N/A	FLOW CONTROL VALVE	1
5	2940-506 2940-543	ON/OFF SOLENOID (COIL ONLY) ON/OFF SOLENOID (CARTRIDGE VALVE)	1
6	N/A	FRAME	1
7	2940-545	ROL-AIR COMPRESSOR PUMP UNIT	1
8	2940-531	RUBBER SPIDER INSERT FOR LOVEJOY COUPLER	1
9	2940-554	HYDRAULIC MOTOR	1
10	N/A	HOUSING COVER	1
11	N/A	MOTOR ELBOW FITTING	1
12	N/A	INLET ELBOW FITTING	1
13	2940-519A	HYDRAULIC COMPRESSOR FAN, CAST (will fit on all Yetter Hyd. Compressors)	1
14	2940-549	HYDRAULIC COMPRESSOR AIR FILTER (FILTER ELEMENT ONLY)	1
15	N/A	FILTER ELBOW	1
16	N/A	BACK GUARD	1
17	N/A	AIR MANIFOLD	1
18	2940-416	175PSI TANK SAFETY RELIEF VALVE	1
19	2940-377	COMPRESSOR PRESSURE SWITCH 125-145PSI	1
20	2940-439	0-160PSI HYDRAULIC COMPRESSOR GAUGE	1
21	2940-635	3/8PTC X 3/8 NPT 90 DEGREE ELBOW FITTING, SWIVEL	1
22	N/A	TANK HOSE	1
23	N/A	INLET HOSE	1
24	N/A	PRESSURE LINE	1
25	2565-058	YETTER DECAL	1
26	2940-544	HYDRAULIC PRESSURE GAUGE WITH ADAPTER 0 - 5000PSI (LIQUID FILLED)	1

# 2940-545 PARTS IDENTIFICATION

**ROLAIR**  
SCHEMATIC FOR  
PMP12MK103

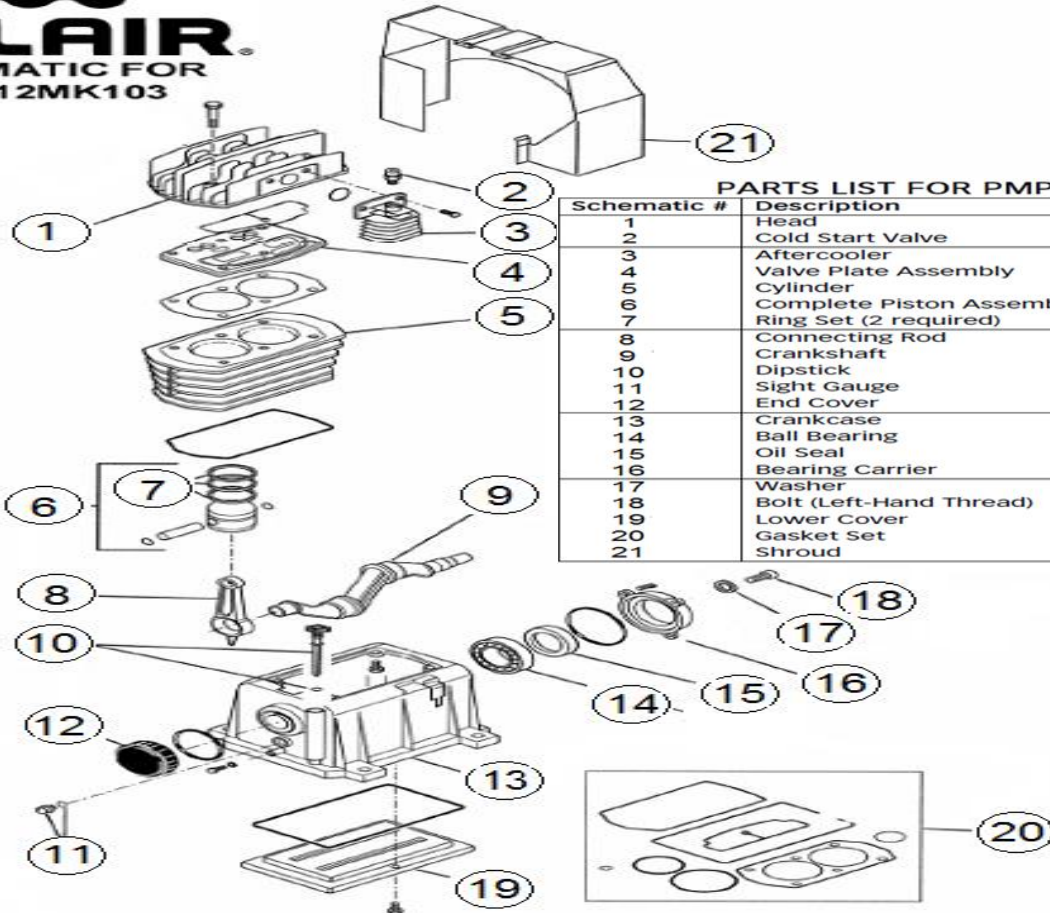

PARTS LIST FOR PMP12MK103

Schematic #	Description	Part #	Qty.
1	Head	FC113167020	1
2	Cold Start Valve	FC011158000	1
3	Aftercooler	FC116091024	1
4	Valve Plate Assembly	FC413167005	1
5	Cylinder	FC113167002	1
6	Complete Piston Assembly	FC413167006	2
7	Ring Set (2 required)	FC213167001	2
8	Connecting Rod	FC113150004	2
9	Crankshaft	FC113167003	1
10	Dipstick	FC312036000	1
11	Sight Gauge	FC012029000	1
12	End Cover	FC113149009	1
13	Crankcase	FC113167001	1
14	Ball Bearing	FC033027000	1
15	Oil Seal	FC010053000	1
16	Bearing Carrier	FC113149008	1
17	Washer	FC014005001	1
18	Bolt (Left-Hand Thread)	FC014001057	1
19	Lower Cover	FC113149015	1
20	Gasket Set	FC213167002	1
21	Shroud	FC113150002	1

# 2940-101A PARTS IDENTIFICATION

Item	Part #	Description	Qty
1	2940-416	175PSI TANK SAFETY RELIEF VALVE	1
2	2940-439	0-160PSI HYDRAULIC COMPRESSOR GAUGE	1
3	N/A	AIR MANIFOLD	1
4	2940-635	3/8PC X 3/8NPT 90° ELBOW FITTING, SWIVEL	1
5	2940-336	HIGH PRESSURE RELIEF VALVE (NO FITTINGS)	1
	1200-323	1/4"PC TO 1/8NPT ELBOW	
6	2940-377	COMPRESSOR PRESSURE SWITCH 125-145PSI	1
7	2940-395	FILTER ELEMENT	1
8	2940-390	ELECTRIC COMPRESSOR	1
9	2940-391	COMPRESSOR RELAY	1
10	N/A	12 GALLON TANK	1
11	N/A	1/4 TURN TANK DRAIN VALVE	1

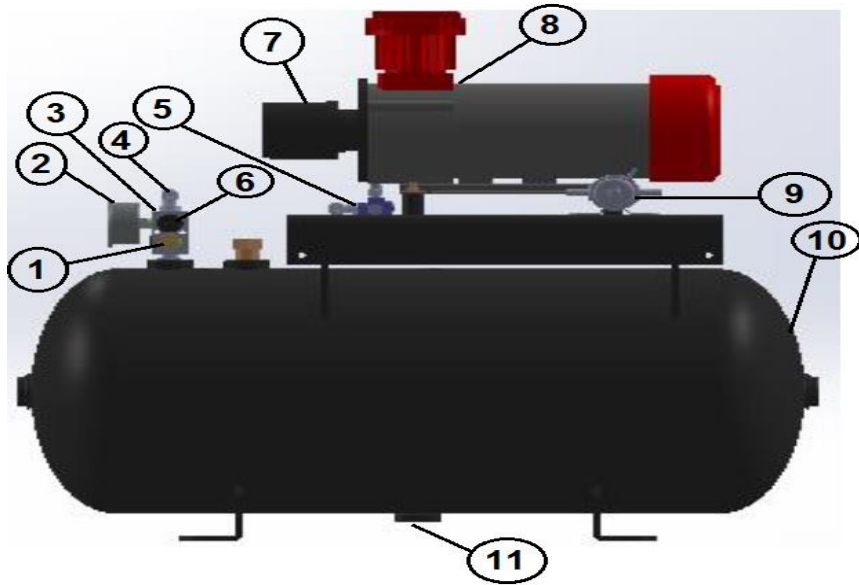

## PARTS IDENTIFICATION

2940-086 DRAFT TUBE/UNIVERSAL COMPRESSOR MOUNT KIT

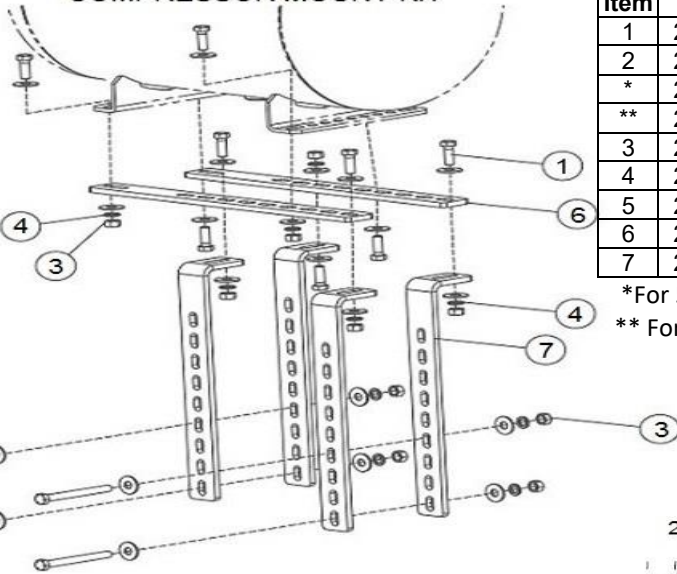

Item	Part #	Description	Qty
1	2502-294	1/2-13 X 1 1/2 HHCS GR 5 ZP	8
2	2502-349	1/2-13 X 5 FLTHD HHCS GR 5 ZP	4
*	2502-371	1/2-13 X 7 GR 5 ZP (NOT INCLUDED)	4
**	2502-374	1/2-13 X 9 GR 5 ZP (NOT INCLUDED)	4
3	2520-352	1/2-13 HEX NUT ZP	12
4	2525-352	1/2 MED LOCK WASHER ZP	12
5	2526-351	1/2 STANDARD FLAT WASHER ZP	24
6	2940-344	COMPRESSOR STRAP	2
7	2940-351	COMPRESSOR MOUNT BRACKET	4

\*For 5"D X 7"T toolbar

\*\* For 7"D X 7"T toolbar

2940-090 8x12 & 2940-091 8x16 HYD COMP MOUNT KIT

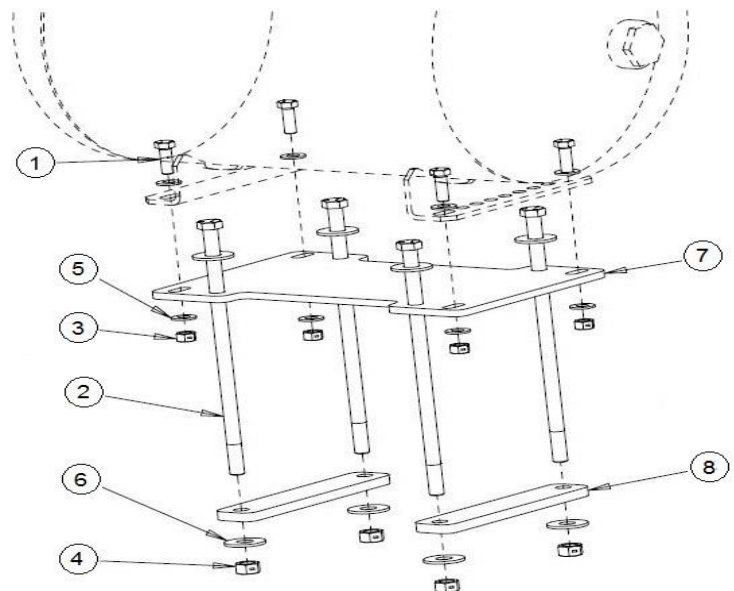

Item	Part #	Description	Qty
1	2502-294	1/2-13 X 1 1/2 HHCS GR 5 ZP	4
2	2502-388	5/8-11 X 14 HHCS GR 5 ZP (IN THE 2940-090 KIT)	4
	2502-389	5/8-11 X 18 HHCS GR 5 ZP (IN THE 2940-091 KIT)	4
3	2520-357	1/2-13 HEX LOCK NUT ZP	4
4	2520-459	5/8-11 HEX LOCK NUT ZP	4
5	2526-352	1/2 STANDARD FLAT WASHER ZP	8
6	2526-451	5/8 STANDARD FLAT WASHER ZP	8
7	2940-372	HYDRAULIC COMPRESSOR MOUNT PLATE	1
8	2940-373	MOUNT STRAP	2

# Troubleshooting Guide

Problem	Cause	Corrective Action
Compressor will not run	<ol style="list-style-type: none"> <li>1. air system is off</li> <li>2. hydraulics disengaged</li> <li>3. no power from battery</li>   <li>4. electrical connection issue</li> <li>5. shut off psi(145psi) reached</li>   <li>6. worn compressor</li> <li>7. Improper pressure switch function</li> </ol>	<ol style="list-style-type: none"> <li>1. Flip switch to ON on cab controller</li> <li>2. engage compressor hydraulic circuit</li> <li>3. check power connections from battery, check 2940-150 breaker at the battery</li> <li>4. check harnesses from cab controller to compressor</li> <li>5. compressor will restart after tank pressure drops below 125psi</li> <li>6. replace compressor</li> <li>7. replace pressure switch</li> </ol>
Compressor runs continuously/air flow lower than normal	<ol style="list-style-type: none"> <li>1. excessive air usage</li> <li>2. loose connections/air leak</li> <li>3. Improper pressure switch function</li> <li>4. clogged air filter element</li> <li>5. worn compressor</li> <li>6. defective safety valve</li> <li>7. tank drain valve open</li> </ol>	<ol style="list-style-type: none"> <li>1. decrease air usage</li> <li>2. perform leak check on all circuits</li> <li>3. replace pressure switch</li> <li>4. clean/replace filter element</li> <li>5. replace compressor pump</li> <li>6. replace safety valve</li> <li>7. close tank drain valve</li> </ol>
Hyd. Compressor struggles to build/won't build 145psi	flow control valve adjustment needed	Adjust flow control on hyd. block <b>(see page 17)</b>
Excessive noise from compressor	<ol style="list-style-type: none"> <li>1. loose mounting bolts</li> <li>2. worn bearings</li> <li>3. cylinder or piston is worn</li> <li>4. compressor over speeding</li> </ol>	<ol style="list-style-type: none"> <li>1. tighten bolts</li> <li>2. replace compressor</li> <li>3. rebuild compressor</li> <li>4. check compressor RPMs &amp; slow motor down if needed, hydraulic plumbing of the compressor is incorrect</li> </ol>
Excessive moisture in circuits	<ol style="list-style-type: none"> <li>1. excessive water in air tank</li> <li>2. high humidity</li> </ol>	<ol style="list-style-type: none"> <li>1. drain tank, drain tank more frequently</li> <li>2. move compressor to area with less humidity.</li> </ol>
Hydraulic motor front seal leakage	<ol style="list-style-type: none"> <li>1. case drain clogged or unplugged</li>   <li>2. case drain not plumbed correctly</li> </ol>	<ol style="list-style-type: none"> <li>1. remove case drain plumbing and clean out debris/obstruction, replace seal</li> <li>2. Plumb case drain according to instructions, replace seal</li> </ol>
Not able to adjust air in a circuit	<ol style="list-style-type: none"> <li>1. regulator adjustment knob locked</li> <li>2. selector valve has activated incorrect circuit</li> <li>3. defective regulator</li> </ol>	<ol style="list-style-type: none"> <li>1. unlock regulator adjustment knob (pull)</li> <li>2. adjust the selector valve to correct circuit</li>   <li>3. replace regulator</li> </ol>
Too much residue in the strip	Row cleaner not set properly	<ol style="list-style-type: none"> <li>1. make row cleaner more aggressive</li> <li>2. make row cleaner less aggressive (if residue is being thrown on row by adjacent row units)</li> </ol>
Strips are not desirable	1. Large clods are left on/in strip	1. decrease row unit depth &/or rolling basket pressure (should decrease wet soil disturbance)
Baskets stop turning	Rocks get stuck between basket paddles	Order/install 1) 2984-175 Kit per row <b>(see page 27)</b>





A Tradition of Solutions since 1930

Yetter Farm Equipment Co

PO BOX 358 109 S. McDonough

Colchester, IL 62326-0358

Phone: 309-776-4111

Toll Free: 800-447-5777

Email: [info@yetterco.com](mailto:info@yetterco.com)

For updated models and manuals visit the Yetter website:

[www.yetterco.com](http://www.yetterco.com)

© Yetter Farm Equipment Co. All Rights Reserved

2565-968\_REV\_H • 06/2026