



2984-150

STRIP FRESHENER™

OPERATOR MANUAL
PARTS IDENTIFICATION
2565-963_REV_A 12/2019



YETTER MANUFACTURING CO.
FOUNDED 1930

Colchester, IL 62326-0358
Toll free: 800/447-5777
309/776-3222 (Fax)
Website: www.yetterco.com
E-mail: info@yetterco.com

GERMINATE UNIFORMITY™

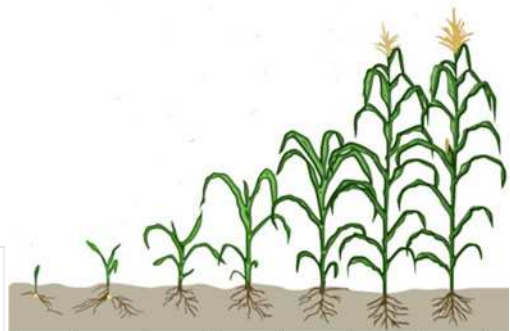

FOREWORD

You've just joined an exclusive but rapidly growing club.

For our part, we want to welcome you to the group and thank you for buying a Yetter product.

We hope your new Yetter products will help you achieve both goals-increase your productivity and increase your efficiency so that you may generate more profit.

This operator's manual has been designed into four major sections: Foreword, Safety Precautions, Installation Instructions and Parts Breakdown.



This **SAFETY ALERT SYMBOL** indicates important safety messages in the manual. When you see this symbol, be alert to the possibility of **PERSONAL INJURY** and carefully read the message that follows.

The word **NOTE** is used to convey information that is out of context with the manual text. It contains special information such as specifications, techniques and reference information of a supplementary nature.

The word **IMPORTANT** is used in the text when immediate damage will occur to the machine due to improper technique or operation. Important will

apply to the same information as specified by note only of an immediate and urgent nature.

It is the responsibility of the user to read the operator's manual and comply with the safe and correct operating procedure and to lubricate and maintain the product according to the maintenance schedule in the operator's manual.

The user is responsible for inspecting his machine and for having parts repaired or replaced when continued use of the product would cause damage or excessive wear to the other parts.

It is the user's responsibility to deliver his machine to the Yetter dealer who sold him the product for service or replacement of defective parts, which are covered by the warranty policy.

If you are unable to understand or follow the instructions provided in this publication, consult your local Yetter dealer or contact:

YETTER MANUFACTURING CO.

309/776-4111

800/447-5777

309/776-3222 (FAX)

Website: www.yetterco.com

E-mail: info@yetterco.com

WARRANTY

Yetter Manufacturing warrants all products manufactured and sold by it against defects in material. This warranty being expressly limited to replacement at the factory of such parts or products as shall appear to be defective after inspection. This warranty does not obligate the Company to bear cost of labor in replacement of parts. It is the policy of the Company to make improvements without incurring obligations to add them to any unit already sold. No warranty is made or authorized to be made, other than herein set forth. This warranty is in effect for one year after purchase.

DEALER _____

Yetter Manufacturing warrants its own products only and cannot be responsible for damages to equipment on which mounted.

SAFETY PRECAUTIONS

A brief description of signal words that may be used in this manual:

CAUTION: Used as a general reminder of good safety practices or to direct attention to unsafe practices.

WARNING: Denotes a specific potential hazard.

DANGER: Denotes the most serious specific potential hazard.



CAUTION

Consult your implement and tractor operator's manual for correct and safe operating practices. Be aware of towed implement width and allow safe clearance.



CAUTION: SAFETY SIGNS

Safety decals are placed on the implement to alert the operator and others to the risk of personal injury or unsafe operation during normal operations and servicing.

1. The safety decals must be kept clean and in good condition to ensure that they are legible.
2. Safety decals must be replaced if they are missing or illegible.
3. When components are replaced during repair or servicing, check that the new components include the necessary safety signs.
4. Replacement safety decals may be obtained from your local dealer.



WARNING

Read these instructions carefully to acquaint yourself with the Equipment. Working with unfamiliar equipment can lead to accidents.

Never park the equipment on a steep incline or leave the equipment running unattended.

Never clean, lubricate or adjust a machine that is in motion.

Always check that straps are secure.

Make sure latches are in pinned position when moving equipment.

Do not allow children to operate this equipment.

Do not allow riders on the equipment, trailer and/or pick-up.

Use speed and caution dictated by the terrain being traversed. Do not operate on any slope steep enough to cause tipping or loss of control.

Read and understand the operator's manual and require all other persons who will operate the equipment to do the same.

If operating on public roadways, where legal, be certain all lighting is operating properly and observe all traffic laws.

Beware of increased stopping distances and control effort when operating with implements attached.

Be familiar with all controls and be prepared to stop equipment quickly in an emergency.

FAILURE TO HEED MAY RESULT IN PERSONAL INJURY OR DEATH.

TABLE OF CONTENTS

FOREWORD.....	2
SAFETY PRECAUTIONS.....	3
2984 STRIP FRESHENER.....	5-7
BOLT TORQUE.....	8
OPERATION PRECAUTIONS.....	9
MAINTENANCE.....	10
PARTS IDENTIFICATION	
2984-150-R.....	11
2984-150-ST.....	12
2984-150-SW.....	13
2984-152.....	14
2966-140-ST.....	15
2966-141-ST.....	16
3000-149.....	17
2984-080.....	18
2984-086-L.....	19
2984-086-R.....	20
ASSEMBLY 2984-086 LIQUID FERTILIZER KIT.....	21

2984 Series Strip Freshener™



STANDARD FEATURES FOR ALL MODELS

- Operating speeds at 6-10 mph and 2"-4" deep
- Blade arrangement and rolling basket conditions existing strips to warm and condition planting zone
- Features parallel linkage to follow field contour and easy adjustments
- Has universal mounting bracket to fit 4" x 4", 4" x 6", 6" x 6", 5" x 7" and 7" x 7" toolbars
- Front bracket enables mounting existing planter attachments for more options
- Photo shown with Optional 2967-029A-ST-FW, [See page 14](#)
- Optional fertilizer attachments available

• Order manual: 2565-963

ORDER from A and B

Section A:

Model No.	Description	Est. Wt.	
2984-150-ST	Strip Freshener, SharkTooth® center blade w/ -ST® closer wheels	360 lbs.	
2984-150-SW	Strip Freshener, 16" 13 SW center blade w/ -ST® closer wheels	360 lbs.	
2984-150-R	Strip Freshener, 16" center Ripple blade w/ -ST® closer wheels	360 lbs.	

-ST denotes SharkTooth® wheel

Section B:

U-bolt Options:			
2984-044	4" x 4" U-bolt assembly	2 lbs.	
2984-046	4" x 6" Adapter kit	21 lbs.	
2984-066	6" X 6" Adapter kit	21 lbs.	
2984-057	5" x 7" U-bolt assembly	2 lbs.	
2984-077	7" x 7" U-bolt assembly	8 lbs.	

Optional Equipment:

2984-080	Liquid Fertilizer Kit Center	1 lb.	
2984-081	Dry Fertilizer Kit Center	3 lbs.	
2984-086-L	LH Fertilizer Tube Bracket	5 lbs.	
2984-086-R	RH Fertilizer Tube Bracket	5 lbs.	



2984-150

Yetter Strip Freshener

Features:

- Adjustable arm linkage for toolbar frame heights between 22-26”
- Can run any style row cleaner in front of the row unit
- Single tillage coulters cleanly cut residue without hair pinning, Optional fluted coulters, smooth coulters, or Shark Tooth Wheel
- Two Shark Tooth wheels run at an angle to churn dirt for optimal seed bed
- Optional fertilizer injector
- Heavy Duty Rolling basket gauges the depth of the row unit.

Model Options:

- Able to utilize Cutting Ripple Coulters, Shallow Wave Coulters, or Shark Tooth Wheel
- 3 models: 2984-150-ST, 2984-150-SW (2571-162), & 2984-150-R (2571-161)
- 9 degree angle on Shark Tooth Wheels
- Has universal mounting bracket to fit 4” X 4”, 4” X 6”, 6” X 6”, 5” X 7”, and 7” X 7” toolbars
 - Operating Speeds at 6-10 mph and 2” – 4” deep

2984-150

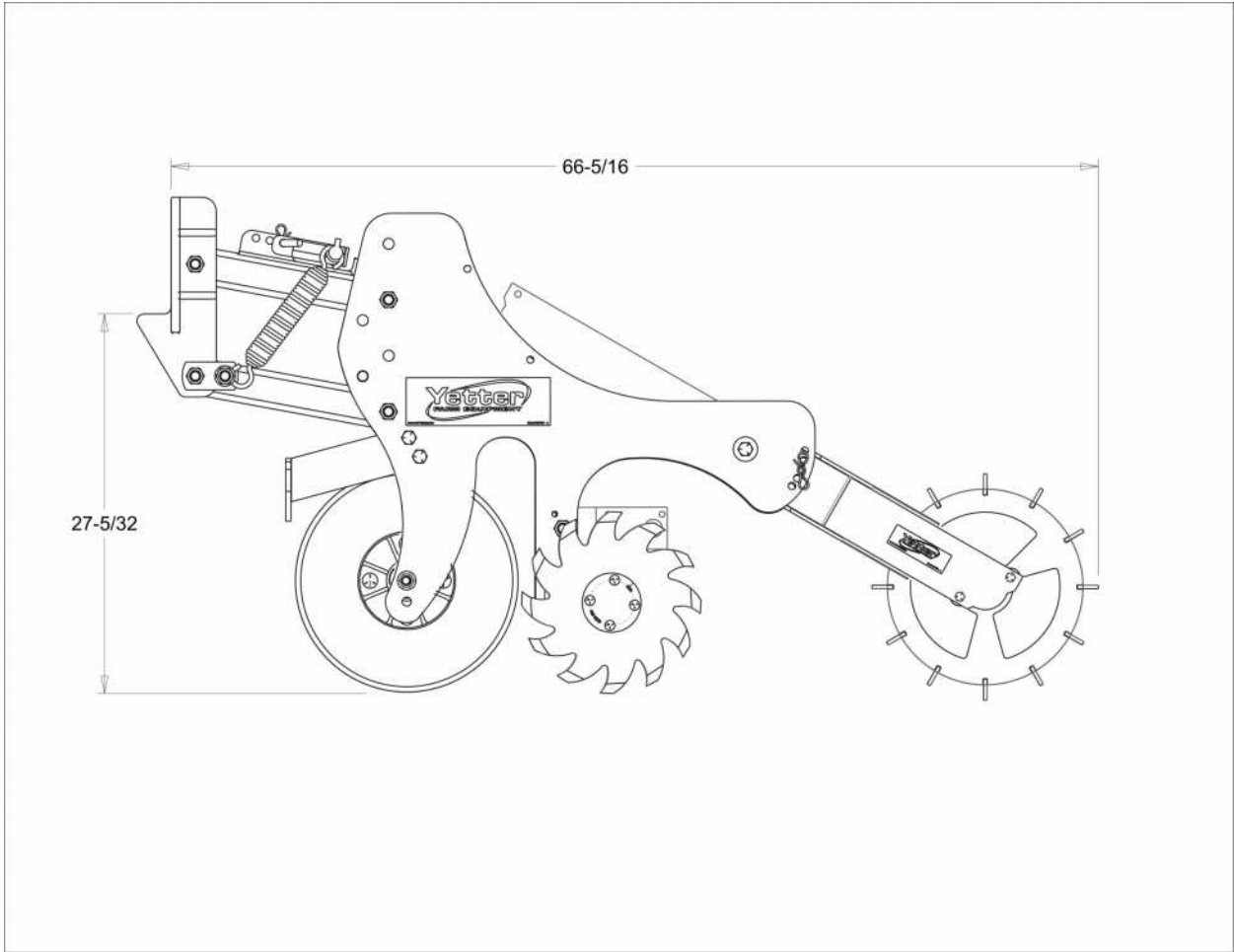

INSTALLATION

BOLT TORQUE

Mounting bolts and hardware

All hardware is Grade 5 unless otherwise noted. Grade 5 cap screws are marked with three radial lines on the head. If hardware must be replaced, be sure to replace it with hardware of equal size, strength and thread type. Refer to the torque values chart when tightening hardware.

Important: Over-tightening hardware can cause just as much damage as under-tightening. Tightening hardware beyond the recommended range can reduce its shock load capacity.







The chart below is a guide for proper torque. Use it unless a specified torque is called out elsewhere in the manual.

Torque is the force applied to the end of the handle or cheater bar, times the length of the handle or bar.

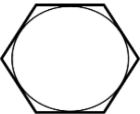
Use a torque wrench wherever possible.

The following table shows torque in ft.-lbs. for coarse thread hardware.

Bolt Diameter and Threads per Inch	 Grade 2	 Grade 5	 A-325	 Grade 8
1/4	6	10		14
5/16	12	20		30
3/8 – 16	25	35		50
7/16 – 14	35	55		80
1/2 – 13	55	85		125
9/16 – 12	75	125		175
5/8 – 11	105	170		235
3/4-10	185	305		425
7/8 – 9	170	445		690
1-8	260	670		1030
1 1/8 – 7	365	900		1460
1 1/4 - 7	515	1275		2060
1 3/8 – 6	675	1675		2700
1 1/2 - 6	900	2150		3500
1 3/4 – 5	1410	3500		5600

Lubricate all bearings and moving parts as assembled and make certain that they work freely.

WARNING: Never work around the toolbar/implement while in a raised position without using safety lockups.

OPERATION PRECAUTIONS

STOP

Read this before using the Yetter product.

- MACHINE OPERATION

IMPORTANT: failure to properly set the planter frame height and levelness can result in less than successful operation of the Yetter product and may result in damaged equipment. All operators should read and thoroughly understand the instructions given prior to using the Yetter product.

NOTE: **DO NOT** use this product if the planter is not adjusted properly!

Leveling the planter:

With the frame lowered to proper operating height (**Usually 22"-26"**) Check to be sure the toolbar is level side to side. **Check** when the toolbar is in the **field** and has been **fully loaded** with fertilizer, etc. Also, a field check with a bubble level on the frame should be made of the hitch height to ensure level operation front to back.

It is important for the toolbar to operate level laterally. Tire pressure must be maintained at pressures specified by the manufacturer.

Field conditions change and will dictate frame heights.

MAINTENANCE



CAUTION: To help prevent serious injury or death to you or other caused by unexpected movement, service machine on a level surface. Lower machine to ground or sufficiently lock or block raised machine before servicing. If machine is connected to a tractor, engage parking brake, place transmission in PARK, shut off engine, and remove the key. If machine is detached from a tractor, block wheel and use shop stands to prevent movement.



CAUTION: Do not clean, lubricate, or adjust a machine while in motion.

Use grease based on NLGI consistency number and the expected air temperature range during the service interval.

Use a **multi-purpose poly urea, water resistant, moderate speed, and NLGI grade #2** grease.

Other greases may be used if they meet the **NLGI Performance Classification: GC-LB**

Important: Some types of grease thickener are not compatible with others. Consult your grease supplier before mixing different types of grease.

Alternative Lubricants

Conditions in certain geographical areas may require special lubricants and lubrication practices which do not appear in the operator's manual. If there are any questions, consult Yetter Manufacturing Co. to obtain the latest information and recommendation.

Part #	Description	Ounces of Grease
2967-404	13" Taper Tooth RM Wheel	1.12 Oz
2967-602	13" Shark Tooth RM Wheel	1.12 Oz
2967-186	Floater Wheel Kit w/ RM Wheel	2.08 Oz
2967-596	Heavy Duty or Bevel R.M. Wheel W/Floater Wheel Kit	2.40 Oz

Storing Lubricants

Your machine can operate at peak efficiency only if clean lubricants are used. Use clean containers to handle all lubricants. Store them in an area protected from dust, moisture, and other contaminants.

PARTS IDENTIFICATION 2984-150-R

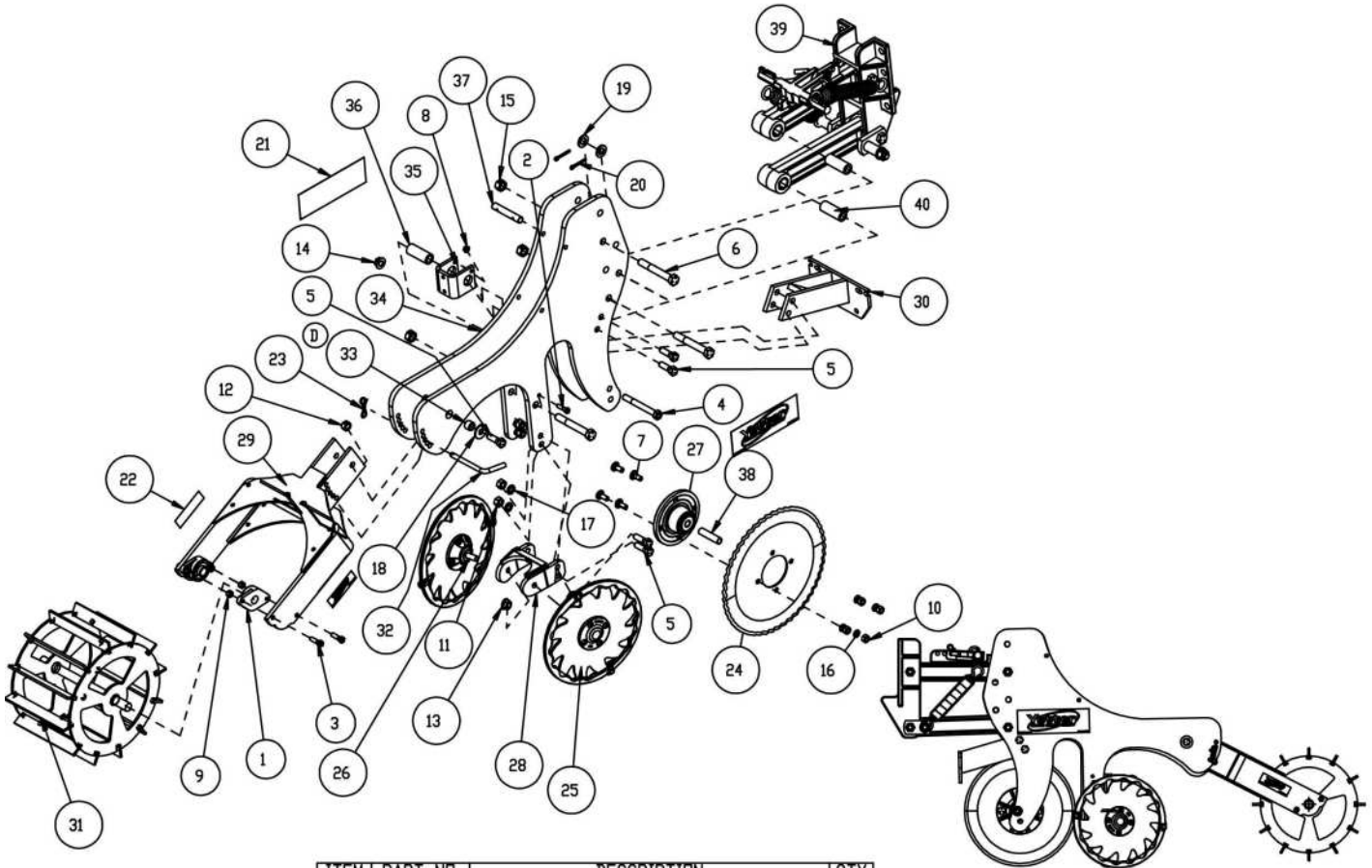

ITEM	PART NO.	DESCRIPTION	QTY
1	1310-333	FLANG MOUNT BEARING	2
2	2502-232	3/8-16 X 1 1/2 HHCS GR 5 ZYD	1
3	2502-266	7/16-14 X 1-1/2 HHCS GR 5 ZP	4
4	2502-384	5/8-11 X 5.5 HHCS GR8 ZP	1
5	2502-391	5/8-11 X 2 HHCS GR 5 ZP	10
6	2502-508	3/4-10 X 5-1/2 HHCS GR5ZYD	3
7	2505-337	1/2-13 X 1 1/4 CARBLT GSZP	4
8	2520-258	3/8-16HEX FLANGE LCK NUT ZP	1
9	2520-267	7/16-14 LCK HX NT ZP	4
10	2520-352	1/2-13 HEX NUT ZP	4
11	2520-452	5/8-11 HEXNUT ZP	8
12	2520-459	5/8-11 LOCK HEX NUT, GR B, ZP	2
13	2520-464	5/8-11 WHIZLOCK HEX NUT, GR 2, ZP	2
14	2520-476	5/8-11 HEX FLANGE NUT	1
15	2520-515	3/4-10 LOCK HEX NUT, GR A, ZP	3
16	2525-352	1/2 MED LOCKWASHER ZP.	4
17	2525-451	5/8 MED. LOCKWASHER ZP.	8
18	2526-451	5/8 STD FLATWASHER	2
19	2526-504	3/4 SAE FLATWASHER, ZP	2
20	2531-125	1/4 X 1-3/4 COTTER PIN ZP	2
21	2565-058	YET FRM EQUI DE 3-7/16X10-5/16	2
22	2565-162	YETTER DECAL	2
23	2570-448	.120BOWTIE LCKING COTT ZP	1
24	2571-161	.157 X 15.94" RIPPLE BLADE	1
25	2966-140-ST	SHARKTOOTH ASSY,RH,3" D-BOLT	1
26	2966-141-ST	SHARKTOOTH ASSY,LH,3" D-BOLT	1
27	2984-152	HUB ASSEMBLY	1
28	2984-234	WHEEL MOUNT V.A.	1
29	2984-235	BASKET MOUNT V.A.	1
30	2984-236	FACEPLATE V.A.	1
31	2984-237	ROLLING BASKET V.A.	1
32	2984-320	PIN, SKID ADJUSTMENT ZYD	1
33	2984-401	REAR PIVOT BUSHING,FLT LNK,ZYD	2
34	2984-432	BODY PLATE	2
35	2984-442	FERTILIZER MOUNT BRACKET	1
36	2984-443	INJ. MOUNT SPACER	1
37	2984-454	DOWNSTOP PIN, ZP	1
38	2984-455	BEARING BORE ADAPTER, ZP	1
39	3000-149	PARALLEL ARM ASSEMBLY '09	1
40	3000-408	INNER BUSHING,NAV LINKAGE ZYD.	2

PARTS IDENTIFICATION 2984-150-ST

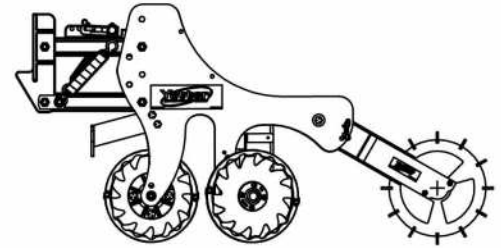
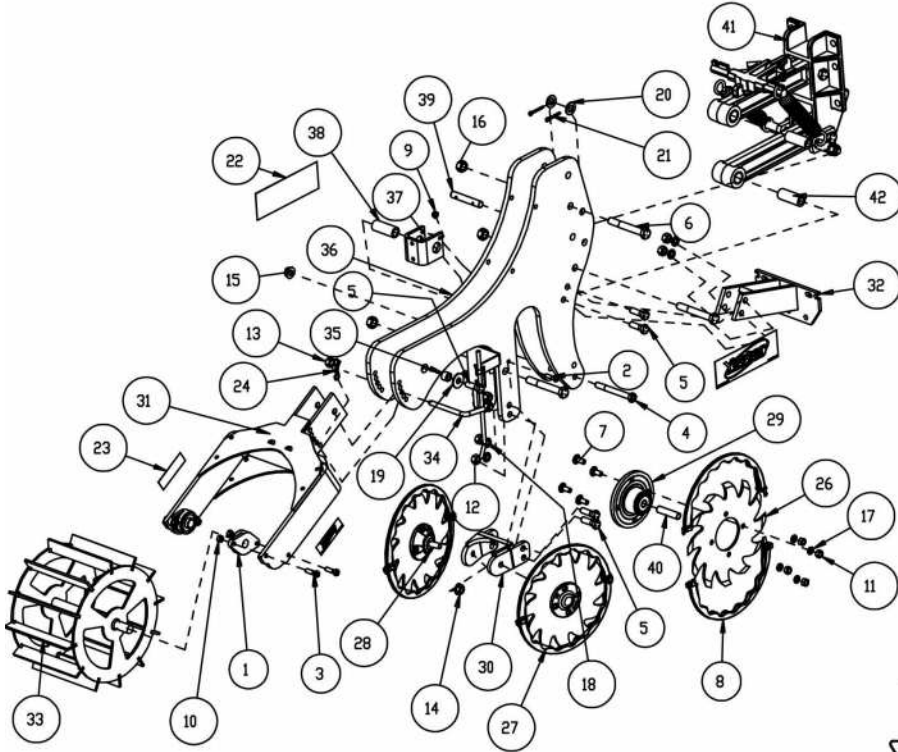

ITEM	PART NO.	DESCRIPTION	QTY
1	1310-333	FLANG MOUNT BEARING	2
2	2502-232	3/8-16 X 1 1/2 HHCS GR 5 ZYD	1
3	2502-266	7/16-14 X 1-1/2 HHCS GR 5 ZP	4
4	2502-384	5/8-11 X 5.5 HHCS GR8 ZP	1
5	2502-391	5/8-11 X 2 HHCS GR 5 ZP	10
6	2502-508	3/4-10 X 5-1/2 HHCS GRSZYD	3
7	2505-337	1/2-13 X 1 1/4 CARBLT GSZP	4
8	2515-562	13" WHEEL COVER, BLACK	2
9	2520-258	3/8-16HEX FLANGE LCK NUT ZP	1
10	2520-267	7/16-14 LCK HX NT ZP	4
11	2520-352	1/2-13 HEX NUT ZP	4
12	2520-452	5/8-11 HEXNUT ZP	8
13	2520-459	5/8-11 LOCK HEX NUT, GR B, ZP	2
14	2520-464	5/8-11 WHIZLOCK HEX NUT, GR 2, ZP	2
15	2520-476	5/8-11 HEX FLANGE NUT	1
16	2520-515	3/4-10 LOCK HEX NUT, GR A, ZP	3
17	2525-352	1/2 MED LOCKWASHER ZP.	4
18	2525-451	5/8 MED. LOCKWASHER ZP.	8
19	2526-451	5/8 STD FLATWASHER	2
20	2526-504	3/4 SAE FLATWASHER, ZP	2
21	2531-125	1/4 X 1-3/4 COTTER PIN ZP	2
22	2565-058	YET FRM EQUI DE 3-7/16X10-5/16	2
23	2565-162	YETTER DECAL	2
24	2570-448	.120BOVIE LCKING COTT ZP	1
25	2570-724	3/8 HOSE P-CLIP W/ VINYL CUSHION	1
26	2920-352	13" SHARK TOOTH WHEEL	1
27	2966-140-ST	SHARKTOOTH ASSY,RH,3" D-BOLT	1
28	2966-141-ST	SHARKTOOTH ASSY,LH,3" D-BOLT	1
29	2984-152	HUB ASSEMBLY	1
30	2984-234	WHEEL MOUNT V.A.	1
31	2984-235	BASKET MOUNT V.A.	1
32	2984-236	FACEPLATE V.A.	1
33	2984-237	ROLLING BASKET V.A.	1
34	2984-320	PIN, SKID ADJUSTMENT ZYD	1
35	2984-401	REAR PIVOT BUSHING,FLT LNK,ZYD	2
36	2984-432	BODY PLATE	2
37	2984-442	FERTILIZER MOUNT BRACKET	1
38	2984-443	INJ. MOUNT SPACER	1
39	2984-454	DOWNSTOP PIN, ZP	1
40	2984-455	BEARING BORE ADAPTER, ZP	1
41	3000-149	PARALLEL ARM ASSEMBLY '09	1
42	3000-408	INNER BUSHING,NAV LINKAGE ZYD.	2

PARTS IDENTIFICATION 2984-150-SW

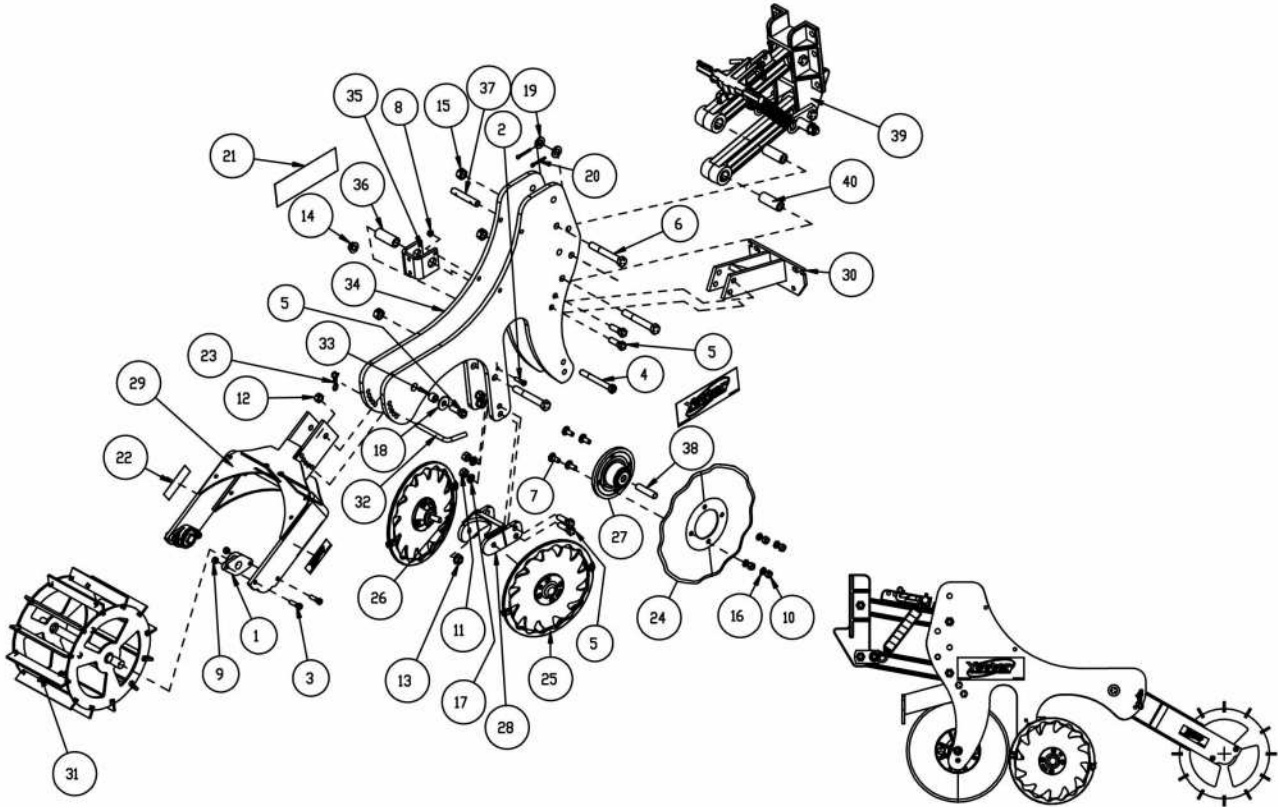

ITEM	PART NO.	DESCRIPTION	QTY
1	1310-333	FLANG MOUNT BEARING	2
2	2502-232	3/8-16 X 1 1/2 HHCS GR 5 ZYD	1
3	2502-266	7/16-14 X 1-1/2 HHCS GR 5 ZP	4
4	2502-384	5/8-11 X 5.5 HHCS GR8 ZP	1
5	2502-391	5/8-11 X 2 HHCS GR 5 ZP	10
6	2502-508	3/4-10 X 5-1/2 HHCS GR5ZYD	3
7	2505-337	1/2-13 X 1 1/4 CARBLT GSZP	4
8	2520-258	3/8-16HEX FLANGE LCK NUT ZP	1
9	2520-267	7/16-14 LCK HX NT ZP	4
10	2520-352	1/2-13 HEX NUT ZP	4
11	2520-452	5/8-11 HEXNUT ZP	8
12	2520-459	5/8-11 LOCK HEX NUT, GR B, ZP	2
13	2520-464	5/8-11 WHIZLOCK HEX NUT, GR 2, ZP	2
14	2520-476	5/8-11 HEX FLANGE NUT	1
15	2520-515	3/4-10 LCK HEX NUT, GR A, ZP	3
16	2525-352	1/2 MED LOCKWASHER ZP.	4
17	2525-451	5/8 MED. LOCKWASHER ZP.	8
18	2526-451	5/8 STD FLATWASHER ZP	2
19	2526-504	3/4 SAE FLATWASHER, ZP	2
20	2531-125	1/4 X 1-3/4 COTTER PIN ZP	2
21	2565-058	YET FRM EQUI DE 3-7/16X10-5/16	2
22	2565-162	YETTER DECAL	2
23	2570-448	.J20BOWTIE LCKING COTT ZP	1
24	2571-162	.157X 15.937" 13 FLUTE BLADE	1
25	2966-140-ST	SHARKTOOTH ASSY,RH,3" D-BOLT	1
26	2966-141-ST	SHARKTOOTH ASSY,LH,3" D-BOLT	1
27	2984-152	HUB ASSEMBLY	1
28	2984-234	WHEEL MOUNT W.A.	1
29	2984-235	BASKET MOUNT W.A.	1
30	2984-236	FACEPLATE W.A.	1
31	2984-237	ROLLING BASKET W.A.	1
32	2984-320	PIN, SKID ADJUSTMENT ZYD	1
33	2984-401	REAR PIVOT BUSHING,FLT LNK,ZYD	2
34	2984-432	BODY PLATE	2
35	2984-442	FERTILIZER MOUNT BRACKET	1
36	2984-443	INJ. MOUNT SPACER	1
37	2984-454	DOWNSTOP PIN, ZP	1
38	2984-455	BEARING BORE ADAPTER, ZP	1
39	3000-149	PARALLEL ARM ASSEMBLY '09	1
40	3000-408	INNER BUSHING,MAV LINKAGE ZYD.	2

PARTS IDENTIFICATION 2984-152

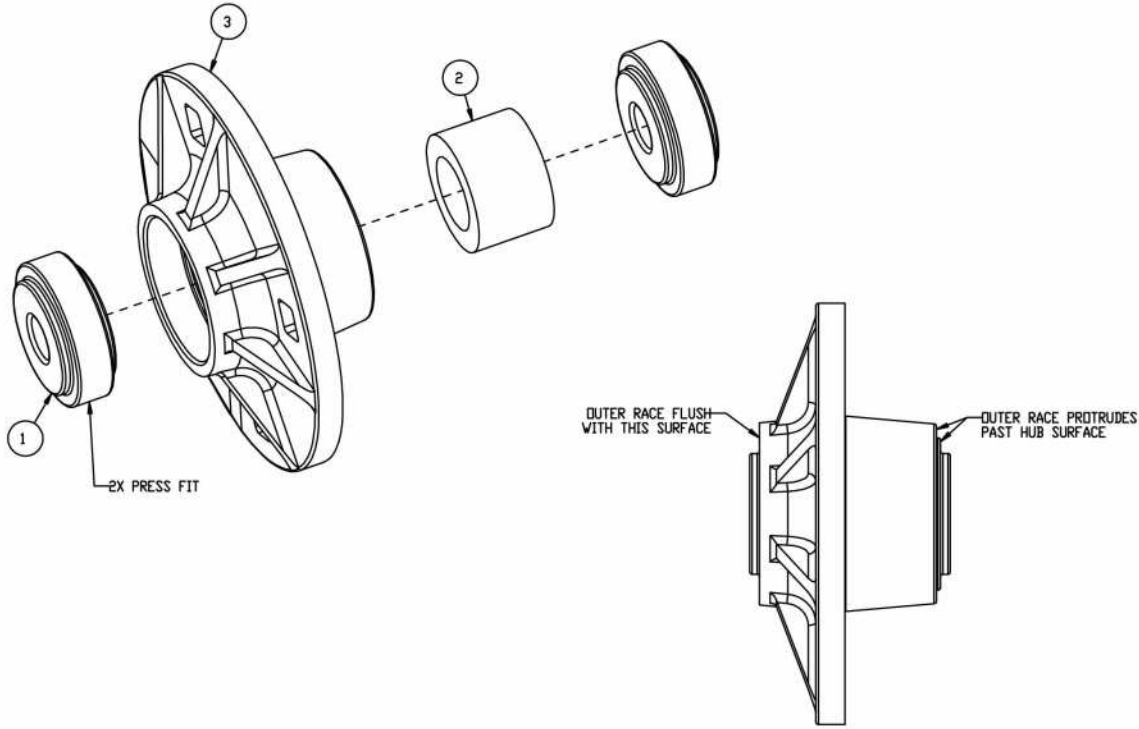

ITEM	PART NO.	DESCRIPTION	QTY
1	2570-575	BEARING, MARKER DISC	2
2	2984-456	BEARING SPACER	1
3	2984-457	STRIP FRESHENER HUB, MACHINED	1

PARTS IDENTIFICATION 2966-140-ST

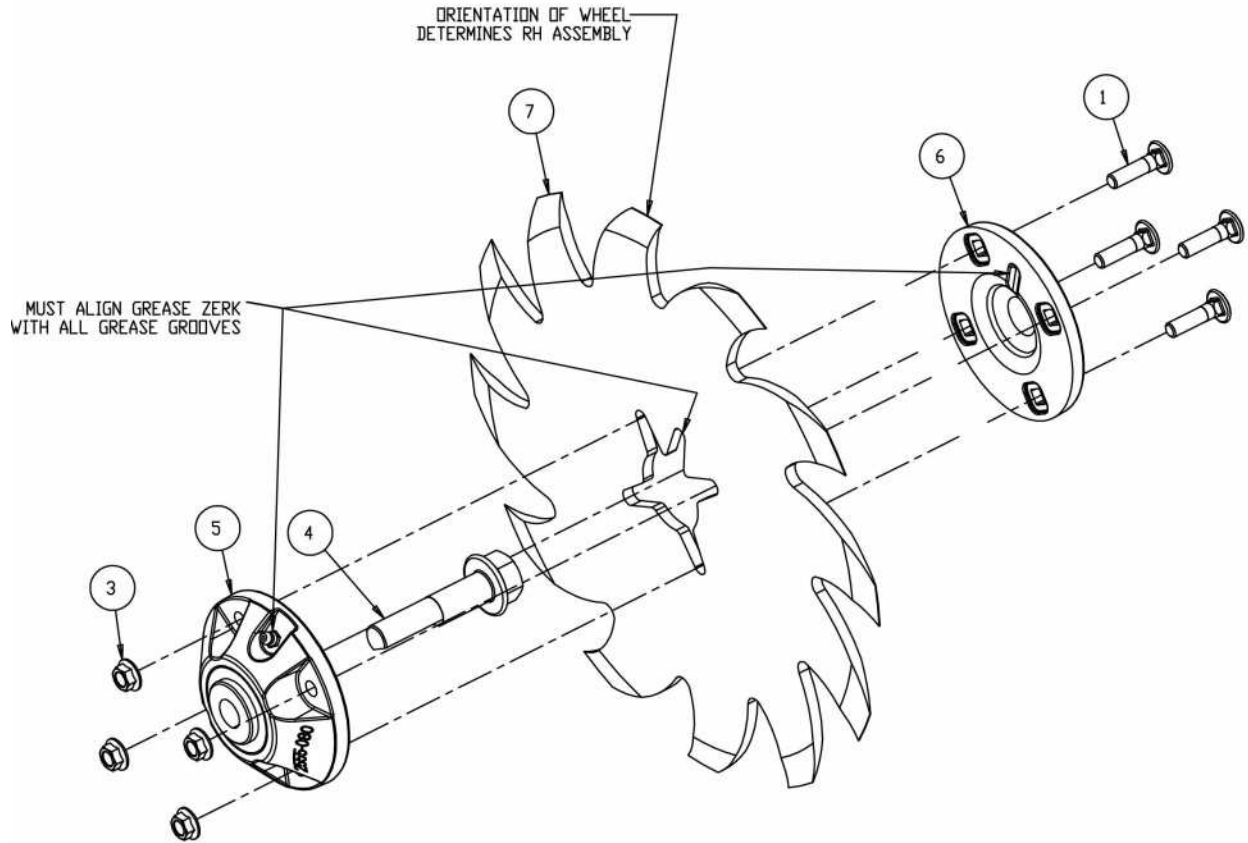

ITEM	PART NO.	DESCRIPTION	QTY
1	2505-207	5/16-18 X 1 1/4 CARBLT GS ZP	4
2	2515-562	13" WHEEL COVER, BLACK, NOT SHOWN	2
3	2520-206	5/16-18 FLANGE LOCK NUT	4
4	2570-740	D-BOLT, FLGD, 5/8-11 X 2.812 GR. 8	1
5	2965-128	HUB AND BEARING ASS'Y, 4 BOLT	1
	2550-069	SEAL, TRIPLE LIP NTI#1812-5	1
	2570-594	BEARING, 2 ROW	1
	2570-715	BEARING INSERT, TRASHMASTER	1
6	2965-352	HUB CAP CASTING, 4 BOLT, BLACK	1
7	2967-602	13" SHARK TOOTH WHEEL	1

PARTS IDENTIFICATION 2966-141-ST

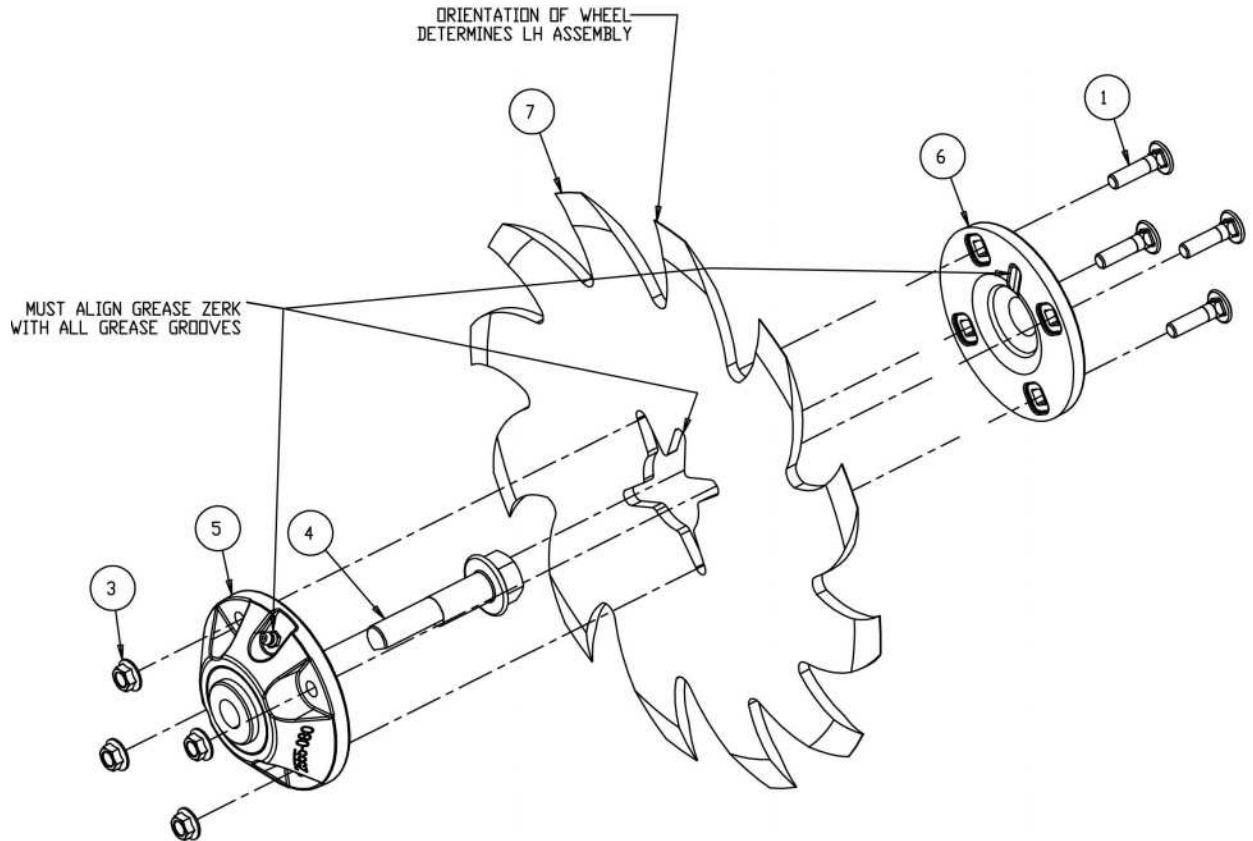

ITEM	PART NO.	DESCRIPTION	QTY
1	2505-207	5/16-18 X 1 1/4 CARBLT G5 ZP	4
2	2515-562	13" WHEEL COVER, BLACK	2
3	2520-206	5/16-18 FLANGE LOCK NUT	4
4	2570-740	D-BOLT, FLGD, 5/8-11 X 2.812 GR. 8	1
5	2965-128	HUB AND BEARING ASS'Y., 4 BOLT	1
	2550-069	SEAL, TRIPLE LIP, NIT# 1812-5	1
	2570-594	BEARING, 2 ROW	1
	2570-715	BEARING INSERT, TRASHMASTER	1
6	2965-352	HUB CAP CASTING, 4 BOLT, BLACK	1
7	2967-602	13" SHARK TOOTH WHEEL	1

PARTS IDENTIFICATION 3000-149

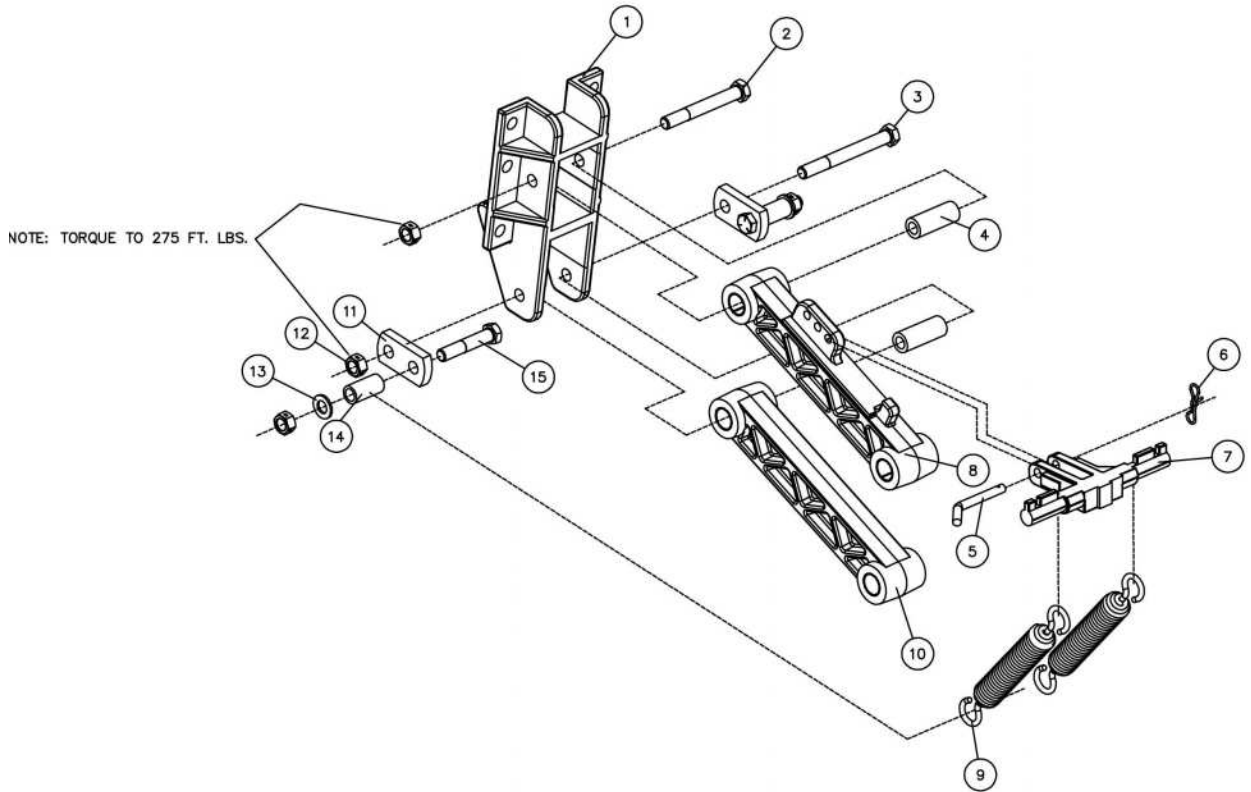

15	2	2502-404	3/4-10 X 4 HHCS GR 5 ZYD
14	2	2984-305	SPACER, SPRING ANCHOR
13	2	2526-504	3/4 SAE FLATWASHER
12	4	2520-515	3/4-10 LOCK HEX NUT ZP
11	2	2984-304	SPRING ANCHOR TAB
10	1	3000-148	LOWER PARALLEL ARM ASSEMBLY
	4	2528-367	PTFE BSHG 1.4190DX1.263IDX1.25
9	2	2550-754	1 5/800 X .262 WIRE EXT SPRING
8	1	3000-147	UPPER PARALLEL ARM ASSEMBLY
	4	2528-367	PTFE BSHG 1.4190DX1.263IDX1.25
7	1	2555-174	UPPER SPRING BAR CASTING
6	1	2570-448	1/8 BOWTIE LOCKING COTTER ZYD
5	1	2965-305	PIN, FURROWING ATTACHMENT ZYD
4	2	3000-408	INNER BUSHING, MAVERICK LINKAGE, ZYD
3	1	2502-509	3/4-10 X 7 HHCS GR. 5 ZYD
2	1	2502-510	3/4-10 X 6 HHCS GR. 5 ZYD
1	1	3000-409	CLAMP BRACKET (MACHINED)
DET	QTY	PART NO.	DESCRIPTION

PARTS IDENTIFICATION 2984-080

LIQ. FERT. KIT, FRESHENER

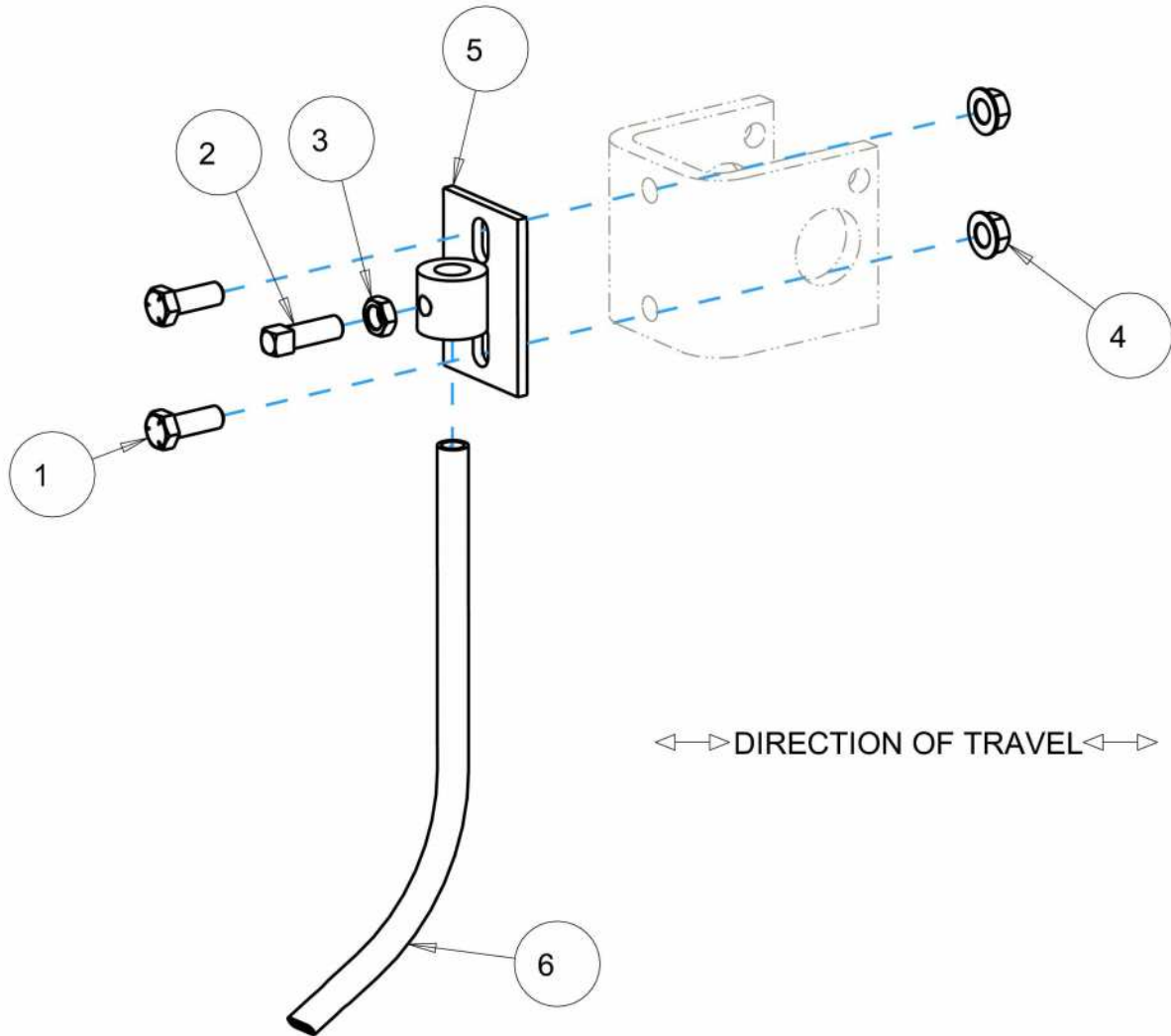

ITEM	PART #	DESCRIPTION	QTY
1	2502-237	3/8-16 X 1 HHCS GR 5 ZP	2
2	2503-254	3/8-16 X 1 SQ. HCPSS, GR5ZP	1
3	2520-253	3/8-16 JAM HEX NUT ZP	1
4	2520-258	3/8-16HEX FLANGE LCK NUT ZP	2
5	2984-238	FERZ TUBE HOLDER STRIP TILL W.A.	1
6	2984-446	STRIP FRESHENER LIQ TUBE	1

PARTS IDENTIFICATION
2984-086-L
LEFT HAND LIQUID FERTILIZER TUBE KIT

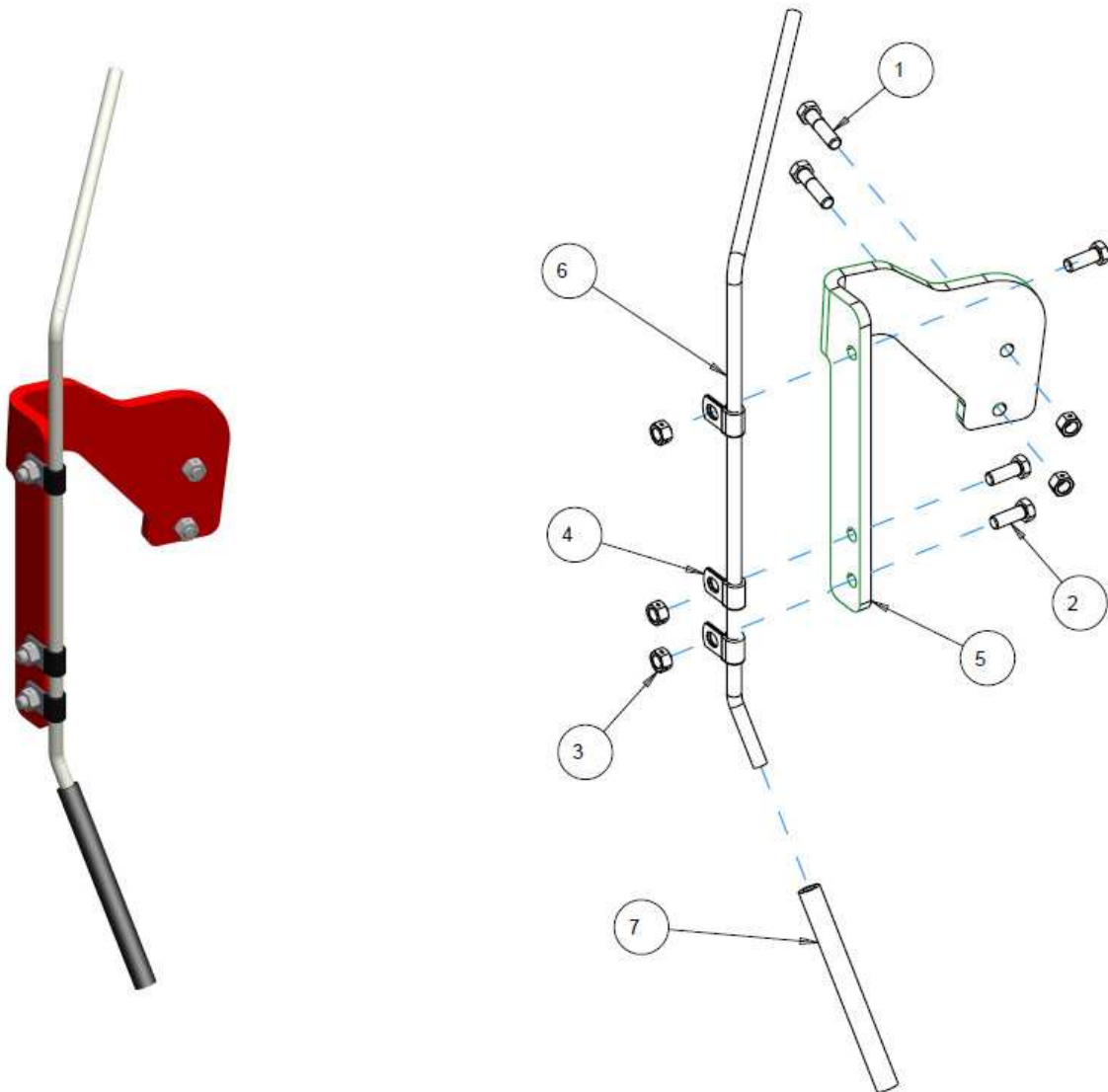

ITEM	PART NO.	DESCRIPTION	QTY
1	2502-232	3/8-16 X 1 1/2 HHCS GR 5 ZYD	2
2	2502-250	3/8-16 X 1 HHCS GR 2 ZN	3
3	2520-255	3/8-16 LOCK HEX NUT, GR A, ZP	5
4	2570-727	3/8 HOSE P-CLIP W/ VINYL CUSHION	3
5	2984-516-L	TUBE BRACKET - LH	1
6	2984-517-L	LIQUID FERTILIZER TUBE	1
7	2984-518	DISCHARGE HOSE	1

PARTS IDENTIFICATION
2984-086-R
RIGHT HAND LIQUID FERTILIZER TUBE KIT

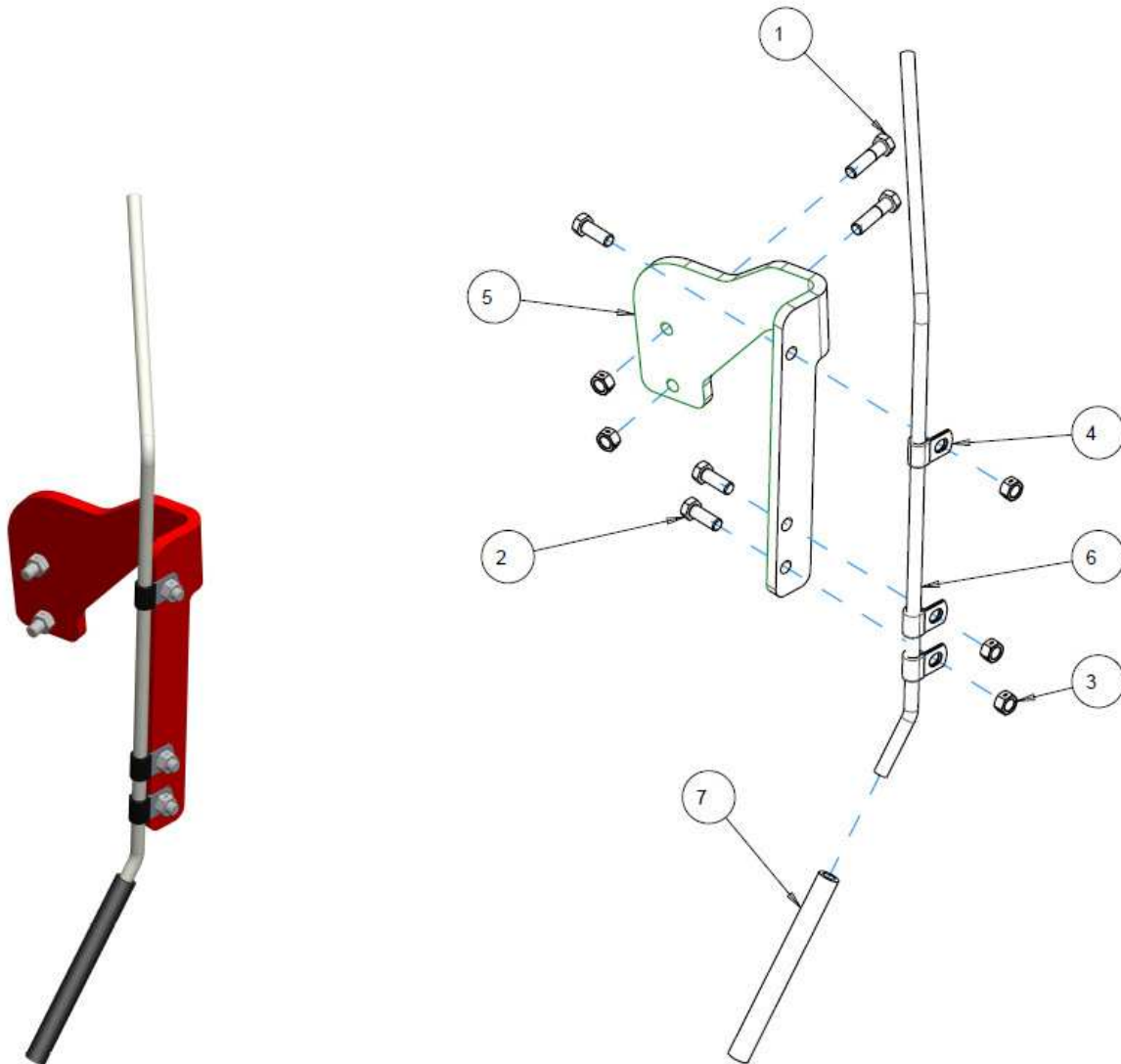

ITEM	PART NO.	DESCRIPTION	QTY
1	2502-232	3/8-16 X 1 1/2 HHCS GR 5 ZYD	2
2	2502-250	3/8-16 X 1 HHCS GR 2 ZN	3
3	2520-255	3/8-16 LOCK HEX NUT, GR A, ZP	5
4	2570-727	3/8 HOSE P-CLIP W/ VINYL CUSHION	3
5	2984-516-R	TUBE BRACKET - RH	1
6	2984-517-R	LIQUID FERTILIZER TUBE	1
7	2984-518	DISCHARGE HOSE	1

ASSEMBLY

2984-086 LIQUID FERTILIZER KIT

LH TUBE BRACKET SHOWN
EXPLODED INTO COMPONENT PARTS

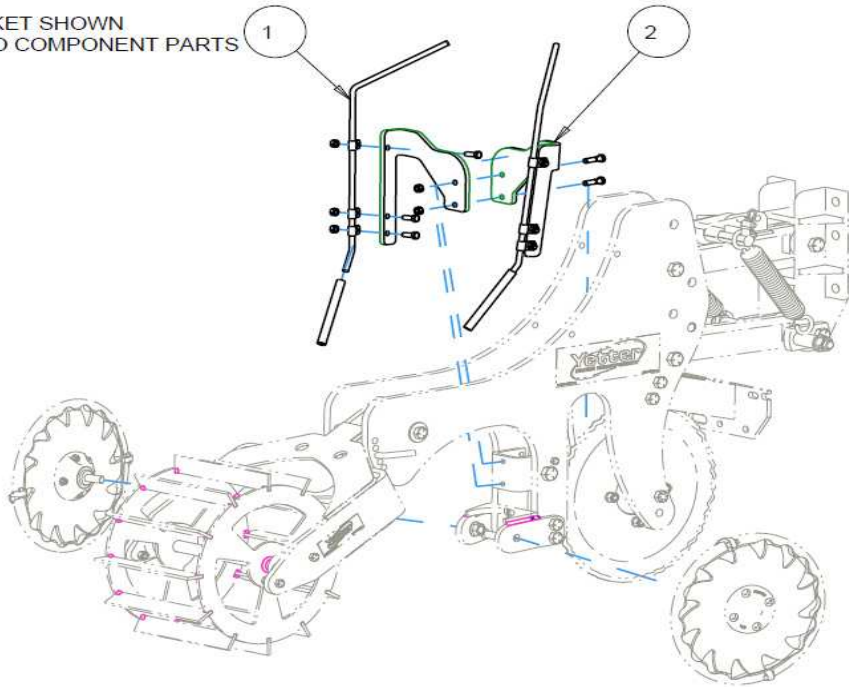

ITEM	PART NO.	DESCRIPTION	QTY
1	2984-086-L	FERTILIZER TUBE BRACKET	1
2	2984-086-R	FERTILIZER TUBE BRACKET	1



NOTES:

NOTES:



A Tradition of Solutions since 1930

Yetter Farm Equipment Co

PO BOX 358 109 S. McDonough

Colchester, IL 62326-0358

Phone: 309-776-4111

Toll Free: 800-447-5777

Email: info@yetterco.com

For updated models and manuals visit the Yetter website:

www.yetterco.com

© Yetter Farm Equipment Co. All Rights Reserved

2565-963_REV_A • 12/2019