



**ROW UNIT MID-MOUNT
FERTILIZER INJECTION OPENER
MODELS 2968-050 & 2968-052 – SINGLE WHEEL
MODELS 2968-051 & 2968-053 – DUAL WHEEL
CNH ROW UNITS
SET UP & PARTS MANUAL
2565-960 – 02/2019**



YETTER MANUFACTURING CO.
FOUNDED 1930
Colchester, IL 62326-0358
Toll free: 800/447-5777
309/776-3222 (Fax)
Website: www.yetterco.com
E-mail: info@yetterco.com

YETTER

TABLE OF CONTENTS

FOREWORD 3
 SAFETY 4
 PICTORIAL PART LIST 5 – 10
 INSTALLATION 10 – 16
 OPERATION 16 – 17
 MAINTENANCE 18 – 20
 PARTS IDENTIFICATION..... 21 – 28

BOLT TORQUE







Important: Over-tightening hardware can cause just as much damage as under-tightening. Tightening hardware beyond the recommended range can reduce its shock load capacity.

All hardware is either Grade 5 unless otherwise noted. Grade 5 cap screws are marked with three radial lines on the head. Grade 8 cap screws are marked with six radial lines on the head. If hardware must be replaced, be sure to replace it with hardware of equal size, strength and thread type. Refer to the torque values chart when tightening hardware.

The chart below is a guide for proper torque. Use it unless a specified torque is called out elsewhere in the manual. Torque is the force applied to the end of the handle or cheater bar, times the length of the handle or bar. Tightening hardware beyond the recommended range can reduce its shock load capacity.

Use a torque wrench wherever possible

The following table shows torque in ft.-lbs. for coarse thread hardware.

Bolt Diameter and Threads per Inch	 Grade 2	 Grade 5	 A-325	 Grade 8
1/4	6	10		14
5/16	12	20		30
3/8 – 16	25	35		50
7/16 – 14	35	55		80
1/2 – 13	55	85		125
9/16 – 12	75	125		175
5/8 – 11	105	170		235
3/4-10	185	305		425
7/8 – 9	170	445		690
1-8	260	670		1030
1 1/8 – 7	365	900		1460
1 1/4 - 7	515	1275		2060
1 3/8 – 6	675	1675		2700
1 1/2 - 6	900	2150		3500
1 3/4 – 5	1410	3500		5600

FOREWORD

You've just joined an exclusive but rapidly growing club.

For our part, we want to welcome you to the group and thank you for buying a Yetter product.

We hope your new Yetter products will help you achieve both goals-increase your productivity and increase your efficiency so that you may generate more profit.

This operator's manual has been designed into four major sections: Foreword, Safety Precautions, Installation Instructions and Parts Breakdown.



This **SAFETY ALERT SYMBOL** indicates important safety messages in the manual. When you see this symbol, be alert to the possibility of **PERSONAL INJURY** and carefully read the message that follows.

The word **NOTE** is used to convey information that is out of context with the manual text. It contains special information such as specifications, techniques and reference information of a supplementary nature.

The word **IMPORTANT** is used in the text when immediate damage will occur to the machine due to improper technique or operation.

Important will apply to the same information as specified by note only of an immediate and urgent nature.

It is the responsibility of the user to read the operator's manual and comply with the safe and correct operating procedure and to lubricate and maintain the product according to the maintenance schedule in the operator's manual.

The user is responsible for inspecting his machine and for having parts repaired or replaced when continued use of the product would cause damage or excessive wear to the other parts.

It is the user's responsibility to deliver his machine to the Yetter dealer who sold him the product for service or replacement of defective parts, which are covered by the warranty policy.

If you are unable to understand or follow the instructions provided in this publication, consult your local Yetter dealer or contact:

YETTER MANUFACTURING CO.
309/776-4111
800/447-5777
309/776-3222 (FAX)
Website: www.yetterco.com
E-mail: info@yetterco.com

WARRANTY

Yetter Manufacturing warrants all products manufactured and sold by it against defects in material. This warranty being expressly limited to replacement at the factory of such parts or products as shall appear to be defective after inspection. This warranty does not obligate the Company to bear cost of labor in replacement of parts. It is the policy of the Company to make improvements without incurring obligations to add them to any unit already sold. No warranty is made or authorized to be made, other than herein set forth. This warranty is in effect for one year after purchase.

DEALER: _____

Yetter Manufacturing warrants its own products only and cannot be responsible for damages to equipment on which mounted.

BE ALERT! YOUR SAFETY IS INVOLVED



WATCH FOR THIS SYMBOL. IT POINTS OUT IMPORTANT SAFETY PRECAUTIONS. IT MEANS “ATTENTION – BE ALERT!”

It is your responsibility as an owner, operator, or supervision to know and instruct everyone using this machine at the time of initial assignment and at least annually thereafter, of the proper operation, precautions, and work hazards which exist in the operation of the machine in accordance with OSHA regulations.

Safety Is No Accident





The following safety instructions, combined with common sense, will save your equipment from needless damage and the operator from unnecessary exposure to personal hazard. Pay special attention to the caution notes in the text. Review this manual at least once a year with all operators.

1. Read and understand the operator's manual before operating this machine. Failure to do so is considered a misuse of the equipment.
2. Make sure equipment is secure before operating.
3. Always keep children away from equipment when operating.
4. Make sure everyone that is not directly involved with the operation is out of the work area before beginning operation.
5. Make sure all safety devices, shields, and guards are in place and functional before beginning operation
6. Shut off all power to adjust, service, or clean.
7. Keep hands, feet, and clothing away from moving parts. It is a good idea to remove all jewelry before operating.
8. Inspect the machine periodically during operation for signs of excessive wear, loose fasteners, and unusual noises.







2968-050 Pictorial Parts List

For CNH 2000 Row Units, Single Disc, Left or Right Hand

 <p>2968-150 QTY 1 Bolt Bag</p>	 <p>2968-227 QTY 1 Close Wheel Mount</p>	 <p>ONLY IF -LH ORDERED 2968-359-LH QTY 1 Short Fert. Wheel Mount, LH</p>	 <p>ONLY IF -RH ORDERED 2968-359-RH QTY 1 Short Fert. Wheel Mount, RH</p>
--	---	--	--

2968-051-L & 2968-051-R Pictorial Parts List

For CNH 2000 Row Units, Dual Disc

 <p>2968-149 QTY 1 Bolt Bag</p>	 <p>2968-227 QTY 1 Close Wheel Mount</p>	 <p>ONLY IF -L ORDERED 2968-359-LH QTY 1 Short Fert. Wheel Mount, LH</p>	 <p>ONLY IF -L ORDERED 2968-360-RH QTY 1 Tall Fert. Wheel Mount, RH</p>	 <p>ONLY IF -R ORDERED 2968-359-RH QTY 1 Short Fert. Wheel Mount, RH</p>	 <p>ONLY IF -R ORDERED 2968-360-LH QTY 1 Tall Fert. Wheel Mount, LH</p>
---	---	---	--	---	--

2968-052 Pictorial Parts List

For CNH 1200 Row Units, Single Disc, Left or Right Hand

 <p>2968-113 QTY 1 Bolt Bag</p>	 <p>2968-226 QTY 1 Close Wheel Mount</p>	 <p>2968-384 QTY 1 Short Fert. Wheel Mount, LH</p>	 <p>2968-385 QTY 1 Short Fert. Wheel Mount, RH</p>
--	---	---	---



2968-053 Pictorial Parts List

For CNH 1200 Row Units, Dual Disc



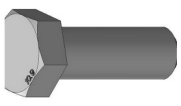
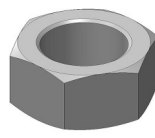

 <p>2968-113 QTY 1 Bolt Bag</p>	 <p>2968-226 QTY 1 Close Wheel Mount</p>	 <p>ONLY IF -LH ORDERED 2968-384 QTY 1 Short Fert. Wheel Mount, LH</p>	 <p>ONLY IF -RH ORDERED 2968-385 QTY 1 Short Fert. Wheel Mount, RH</p>
--	---	---	---

2968-054 Pictorial Parts List



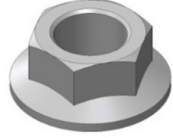

Box Mount Kit For CNH 1200 Row Units, Dual Disc

 <p>2502-807 QTY 8 M16X2X80 Bolt</p>	 <p>2520-477 QTY 1 M16X2 Hex Nut</p>	 <p>2968-374 QTY 2 Box Mount Bracket</p>	 <p>2968-375 QTY 4 Box Mount Spacer</p>
---	---	---	--

2968-132 Pictorial Parts List – 10” Fertilizer Wheel Assembly

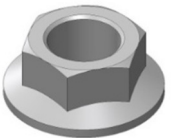
 <p>2505-207 QTY 4 5/16 X 1 1/4 Carriage Bolt</p>	 <p>2520-206 QTY 4 5/16 Flange Lock Nut</p>	 <p>2570-740 QTY 1 Flanged D-Bolt 5/8 X 2.812 GR 8</p>	 <p>2965-128 QTY 1 Hub & Bearing Assembly, 4 bolt</p>	 <p>2965-352 QTY 1 Hub Cap Casting</p>	 <p>2968-320 QTY 1 10” Notched Blade</p>
--	--	---	--	---	---

2968-133 Pictorial Parts List – 11” Fertilizer Wheel Assembly

 <p>2505-207 QTY 4 5/16 X 1 1/4 Carriage Bolt</p>	 <p>2520-206 QTY 4 5/16 Flange Lock Nut</p>	 <p>2570-740 QTY 1 Flanged D-Bolt 5/8 X 2.812 GR 8</p>	 <p>2965-128 QTY 1 Hub & Bearing Assembly, 4 bolt</p>	 <p>2965-352 QTY 1 Hub Cap Casting</p>	 <p>2968-364 QTY 1 11” Notched Blade</p>
--	--	---	--	---	---

2968-113 Pictorial Parts List

Bolt Bag for 2968-052

2505-207 – 5/16 – 18 X 1 ¾ CARRIAGE BOLT – QTY 4 

 ← 2505-208 – 5/16 – 18 X 1 ½ CARRIAGE BOLT – QTY 4

2505-345 – ½ – 13 X 2 CARRIAGE BOLT – QTY 3 

 ← 2515-846 -MALE CONNECTOR - 3/8 X 1/4 NPTF– QTY 1

2520-206 – 5/16 FLANGE LOCK NUT – QTY 8 

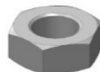
 ← 2520-253 3/8 JAM HEX NUT – QTY 2

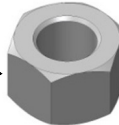
2520-357 1/2-13 LOCK HEX NUT, GR A, ZP– QTY 3 

 ← 2520-464 -5/8-11 WHIZLOCK ZP, GR 8– QTY 1

2525-251 -3/8 MED. LOCKWASHER ZP – QTY 1 

 ← 2526-253 – 3/8 SAE FLAT WASHER ZP – QTY 2

2526-355 – ½ FLAT WASHER HRD'ND ZP – QTY 3 

 ← 2526-454 - 5/8 SAE FLATWASHER HRD'ND ZP – QTY 1

2570-448 - .120 BOWTIE LOCKING COTTER ZP – QTY - 1 

 ← 2968-218 - INJECTOR HOLDER W.A. – QTY 1

2968-383 – TRIANGULAR MOUNT SPACER ZP – QTY 4 

 ← 2968-386 – TRIANGULAR MOUNT – QTY 2

2984-497 – AIR CYLINDER ROD PIN – QTY 1 

2968-114 Pictorial Parts List

Bolt Bag for 2968-053

2505-207 – 5/16 – 18 X 1 3/4 CARRIAGE BOLT – QTY 4 → 

 ← 2505-208 – 5/16 – 18 X 1 1/2 CARRIAGE BOLT – QTY 4

2505-343 – 1/2 – 13 X 2 1/2 CARRIAGE BOLT – QTY 3 → 

 ← 2505-345 – 1/2 – 13 X 2 CARRIAGE BOLT – QTY 3

2515-846 -MALE CONNECTOR - 3/8 X 1/4 NPTF- QTY 2 → 

2520-206 – 5/16 FLANGE LOCK NUT – QTY 8 → 

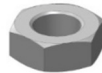
 ← 2520-253 3/8 JAM HEX NUT – QTY 4

2520-357 1/2-13 LOCK HEX NUT, GR A, ZP- QTY 3 → 

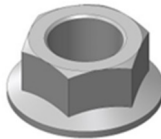
 ← 2520-464 -5/8-11 WHIZLOCK ZP, GR 8- QTY 2

2525-251 -3/8 MED. LOCKWASHER ZP – QTY 2 → 

 ← 2526-253 – 3/8 SAE FLAT WASHER ZP – QTY 4

2526-355 – 1/2 FLAT WASHER HRD'ND ZP – QTY 3 → 

 ← 2526-454 - 5/8SAE FLATWASHER HRD'ND ZP – QTY 2

2570-448 - .120 BOWTIE LOCKING COTTER ZP – QTY - 1 → 

 ← 2968-218 - INJECTOR HOLDER W.A. – QTY 2

2968-383 – TRIANGULAR MOUNT SPACER ZP – QTY 4 → 

 ← 2968-386 – TRIANGULAR MOUNT – QTY 2

2984-497 – AIR CYLINDER ROD PIN – QTY 1 → 

2968-149 Pictorial Parts List – Bolt Bag for 2968-051

2502-314 – 1/2-13 X 2-1/4" HHCS GR 5 ZYD – QTY 3 → 

 ← 2502-333 – 5/8 – 11 X 9 HHCS GR 5 ZP – QTY 1

2502-373 – 1/2 – 13 X 6 HHCS GR 5 ZP – QTY 1 → 

 ← 2502-808 – M16 X 40MM SERRATED HEX FLANGE ZP – QTY 4

2515-846 -MALE CONNECTOR - 3/8 X 1/4 NPTF– QTY 2 → 

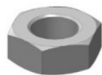
 ← 2520-253 3/8 JAM HEX NUT – QTY 4

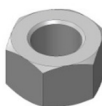
2520-357 1/2-13 LOCK HEX NUT, GR A, ZP– QTY 4 → 

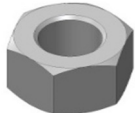
 ← 2520-459 5/8 – 11 LOCK HEX NUT GR A ZP – QTY – 1

2520-464 -5/8-11 WHIZLOCK ZP, GR 8– QTY 2 → 

 ← 2525-251 -3/8 MED. LOCKWASHER ZP – QTY 2

2526-253 – 3/8 SAE FLAT WASHER ZP – QTY 4 → 

 ← 2526-351 – 1/2 STANDARD FLAT WASHER ZP – QTY – 5

2526-355 – 1/2 FLAT WASHER HRD'ND ZP – QTY 5 → 

 ← 2526-451 - 5/8 STANDARD FLATWASHER ZP – QTY 2

2526-454 - 5/8SAE FLATWASHER HRD'ND ZP – QTY 2 → 

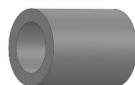
 ← 2967-567 – PIVOT BUSHING – QTY – 2

2968-218 - INJECTOR HOLDER W.A. – QTY 2 → 

2968-150 Pictorial Parts List – Bolt Bag for 2968-050

2502-317 – 1/2-13 X 1 3/4" HHCS GR 5 ZYD – QTY 3 →



← 2502-333 – 5/8 – 11 X 9 HHCS GR 5 ZP – QTY 1

2502-373 – 1/2 – 13 X 6 HHCS GR 5 ZP – QTY 1 →



← 2502-808 – M16 X 40MM SERRATED HEX FLANGE ZP – QTY 4

2515-846 -MALE CONNECTOR - 3/8 X 1/4 NPTF– QTY 1 →

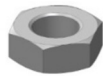

← 2520-253 3/8 JAM HEX NUT – QTY 2

2520-357 1/2-13 LOCK HEX NUT, GR A, ZP– QTY 4 →

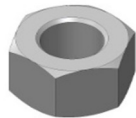

← 2520-459 5/8 – 11 LOCK HEX NUT GR A ZP – QTY – 1

2520-464 -5/8-11 WHIZLOCK ZP, GR 8– QTY 1 →

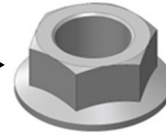

← 2525-251 -3/8 MED. LOCKWASHER ZP – QTY 1

2526-253 – 3/8 SAE FLAT WASHER ZP – QTY 2 →



← 2526-351 – 1/2 STANDARD FLAT WASHER ZP – QTY – 5

2526-355 – 1/2 FLAT WASHER HRD'ND ZP – QTY 5 →



← 2526-451 - 5/8 STANDARD FLATWASHER ZP – QTY 2

2526-454 - 5/8SAE FLATWASHER HRD'ND ZP – QTY 1 →

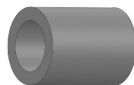

← 2967-567 – PIVOT BUSHING – QTY – 2

2968-218 - INJECTOR HOLDER W.A. – QTY 1 →



INSTALLATION INSTRUCTIONS

Step 1: Remove the items listed below that are part of the closing wheel assembly on the seeding unit. The closing discs will remain in the same location directly behind the gauge wheels.

1200 SERIES ROW UNIT

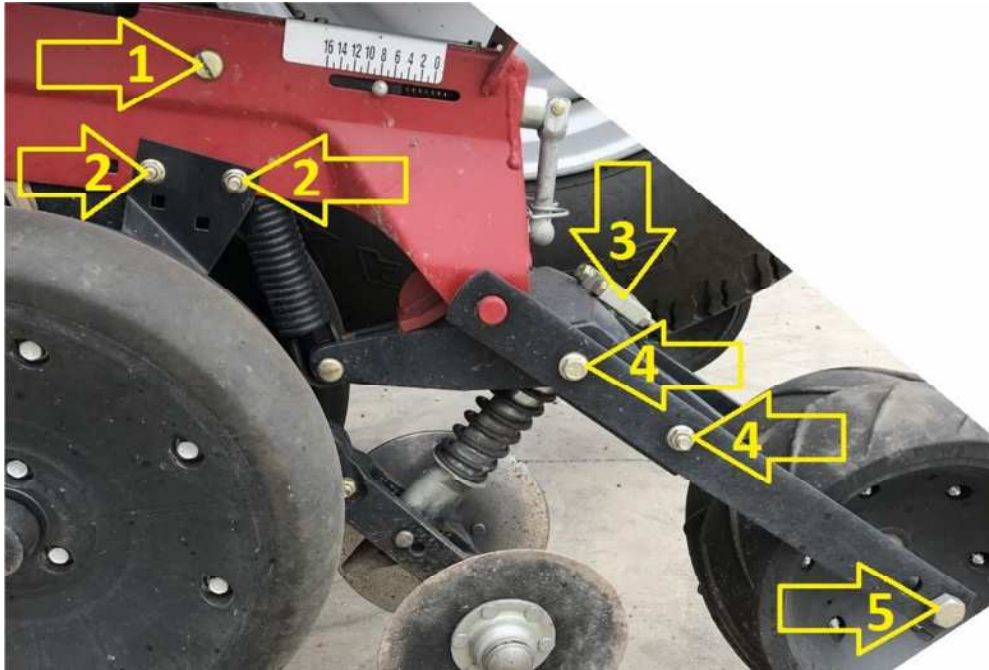

- 1 – SPRING PIN & CLIP
- 2 – HARDWARE FOR THE DISC SCRAPER
- 3 – HARDWARE THAT ATTACHES THE SPRING HOLDER
- 4 – HARDWARE FOR THE PRESS WHEEL BRACKET
- 5 – HARDWARE FOR THE PRESS WHEEL
- OPTIONAL – EACH GAUGE WHEEL

2100 SERIES ROW UNIT

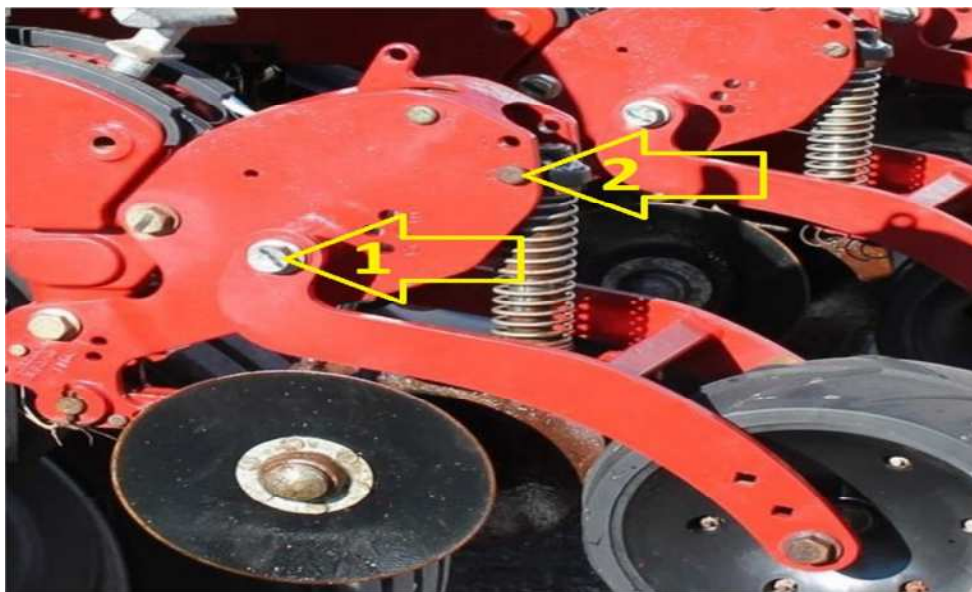

- 1 – HARDWARE FOR THE PRESS WHEEL BRACKET
- 2 – HARDWARE THAT ATTACHES THE PRESS WHEEL SPRING HOLDER

INSTALLATION INSTRUCTIONS

Step 2: Attach the front of the Main Mount Bracket to each planter row unit. Attach the rear firming wheel & compression spring to the rear of the main mount bracket. On CNH 1200 row units, attach the closing wheel springs to the Main Mount Bracket.

1200 SERIES ROW UNIT

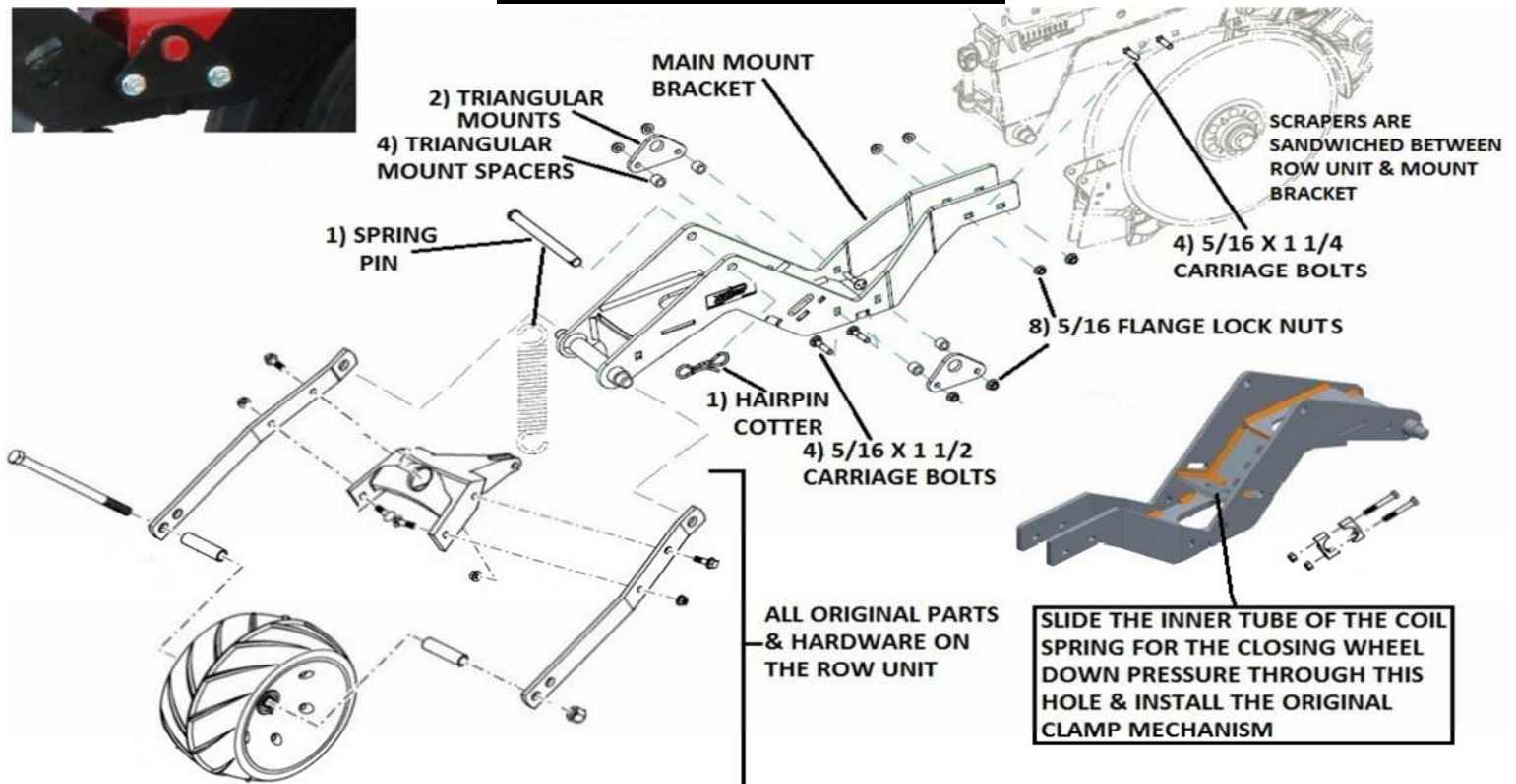

2100 SERIES ROW UNIT

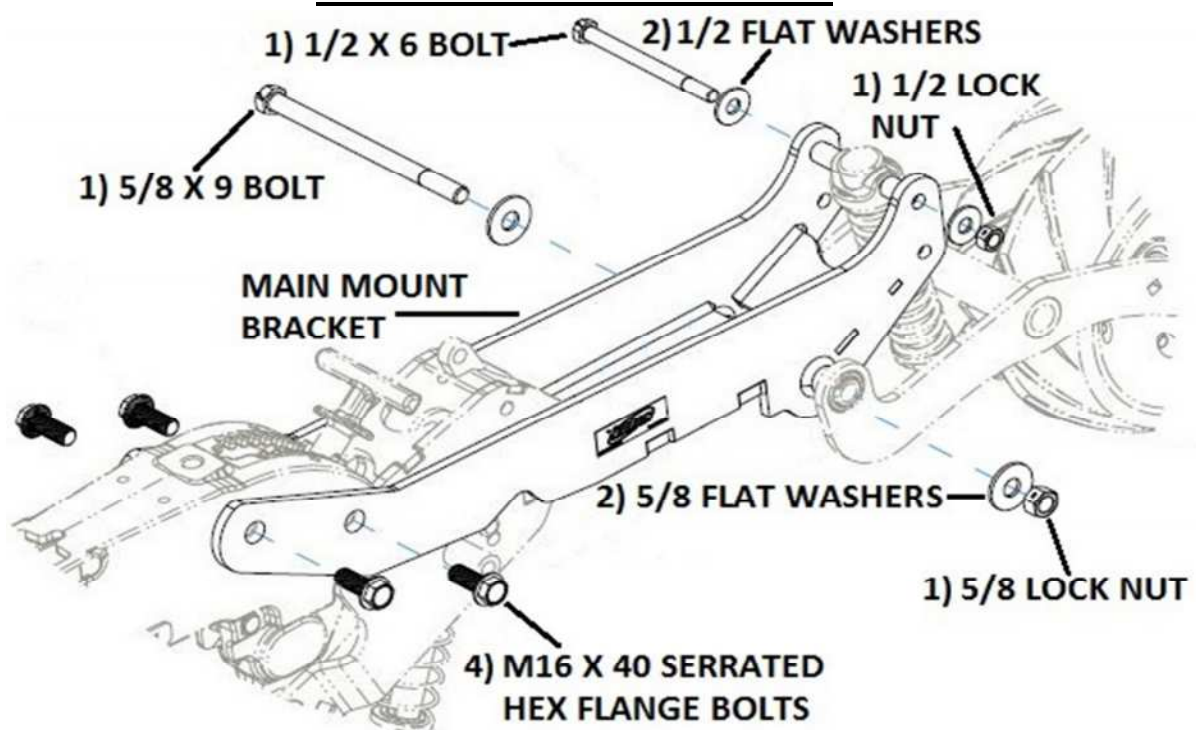

2968-050 & 2968-052 INSTALLATION INSTRUCTIONS

SINGLE DISC PLACEMENT

Step 3: Install the fertilizer wheel mount to the main mount bracket using 3) 1/2 X 2 1/4 bolts, 3) 1/2 flat washers, & 3) 1/2 lock nuts. Install each wheel assembly by placing a 5/8 flat washer over the D-Bolt, slide the D-Bolt through the hole to set the depth of the blade (see page 16 for depth chart), & install a 5/8 whiz lock nut. Install the injector holder by threading 1) 3/8 jam nut approximately 2" onto the threads. Place a 3/8 flat washer on the threads & slide the threads through the horizontally slotted hole. Place a 3/8 flat washer over the threads, followed by a 3/8 lock washer, & thread a 2nd 3/8 nut on the threads. Adjust the injector holder to be centered behind the blade & fasten in place. Install the male connector on the top of the injector holder.

NOTE: IF INSTALLING THE REAR KNIFE ASSEMBLIES INSTEAD OF INJECTOR HOLDERS, SEE THE REAR KNIFE MANUAL

5000-050-L (SHOWING INJECTOR ASSEMBLY) 5000-050-R (SHOWING BLADE ASSEMBLY)

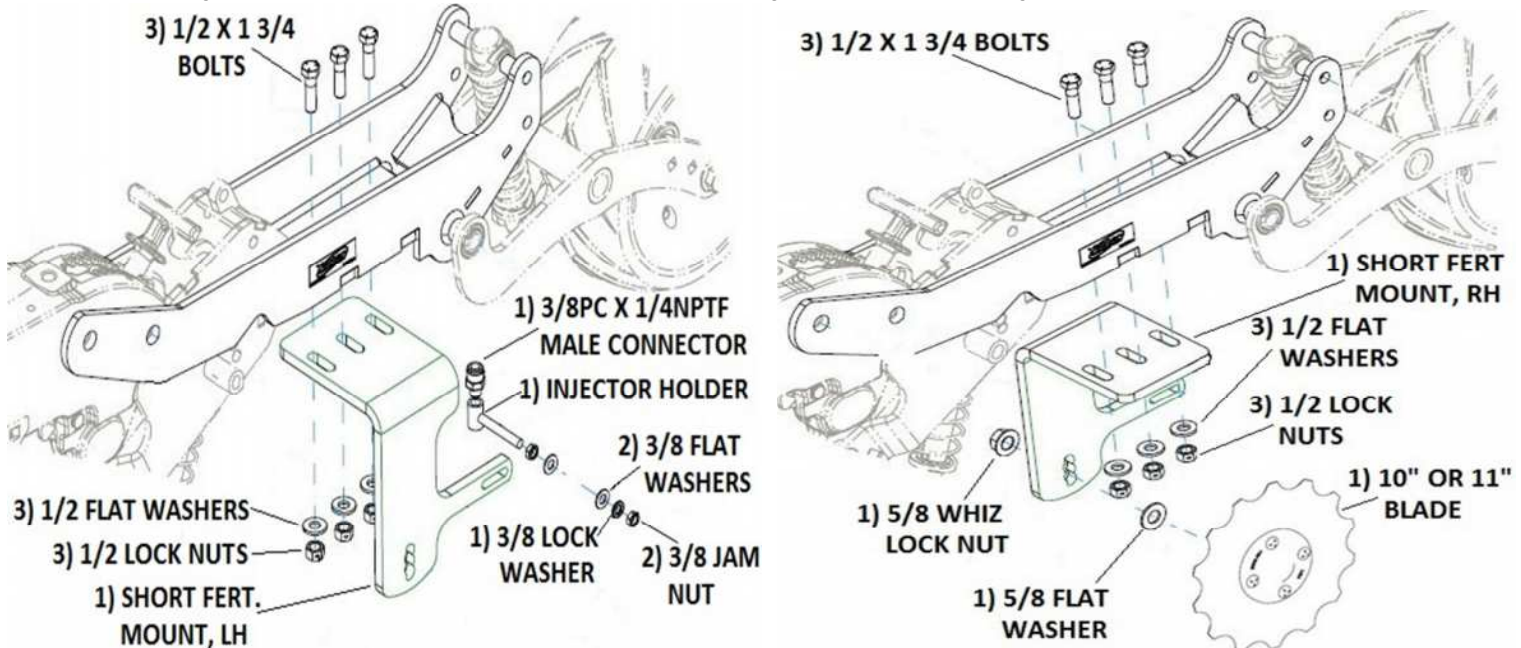

5000-052-L (SHOWING INJECTOR ASSEMBLY) 5000-052-R (SHOWING BLADE ASSEMBLY)

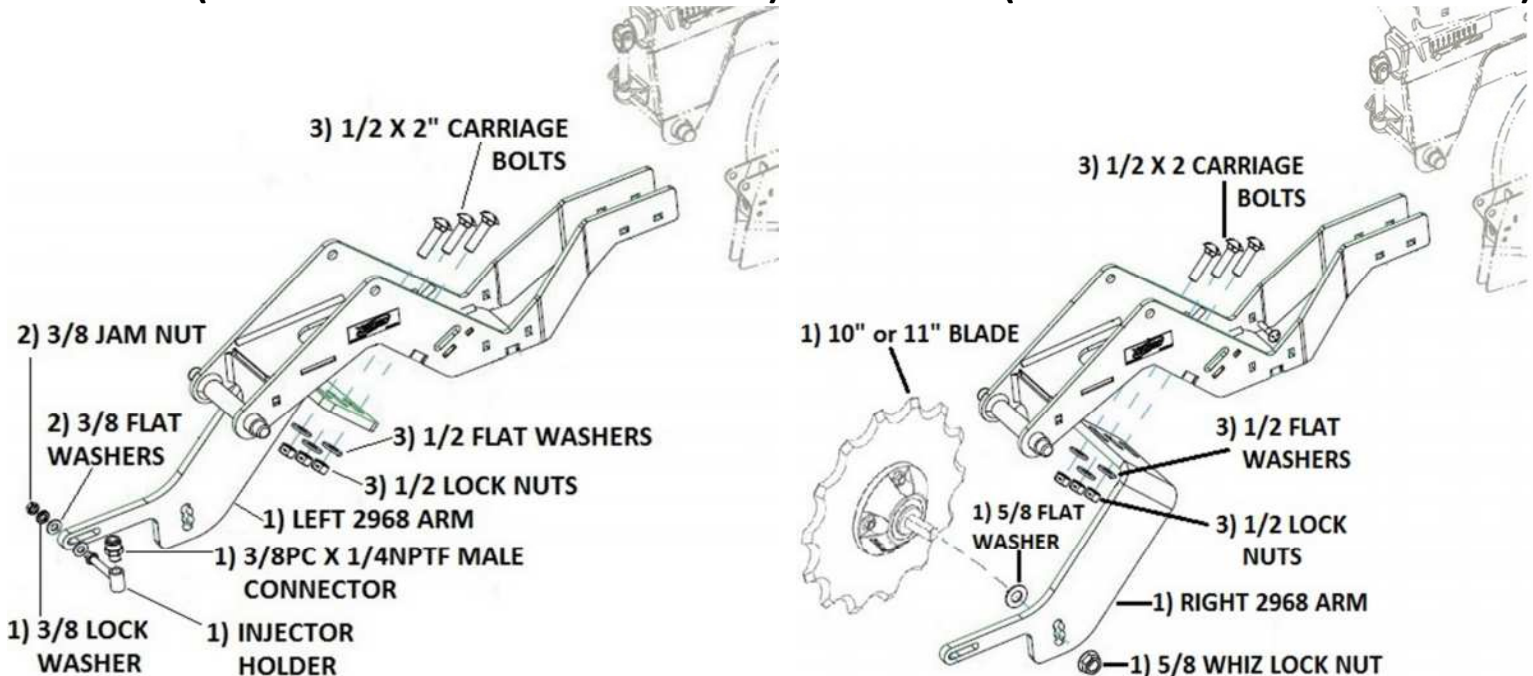

2968-051 INSTALLATION INSTRUCTIONS

DUAL DISC PLACEMENT

Step 3: Install the fertilizer wheel mounts to the main mount bracket using 3) 1/2 X 2 1/4 bolts, 3) 1/2 flat washers, & 3) 1/2 lock nuts. On the seeding units where the left closing wheel is leading, install a 2968-051-L. On the seeding units where the right closing wheel is leading, install a 2968-051-R. Install each wheel assembly by placing a 5/8 flat washer over the D-Bolt, slide the D-Bolt through the hole to set the depth of the blade (see page 16 for depth chart), & install a 5/8 whiz lock nut. Install the injector holder by threading 1) 3/8 jam nut approximately 2" onto the threads. Place a 3/8 flat washer on the threads & slide the threads through the horizontally slotted hole. Place a 3/8 flat washer over the threads, followed by a 3/8 lock washer, & thread a 2nd 3/8 nut on the threads. Adjust the injector holder to be centered behind the blade & fasten in place. Install the male connector on the top of the injector holder.

NOTE: IF INSTALLING THE REAR KNIFE ASSEMBLIES INSTEAD OF INJECTOR HOLDERS, SEE THE REAR KNIFE MANUAL

2968-051-L

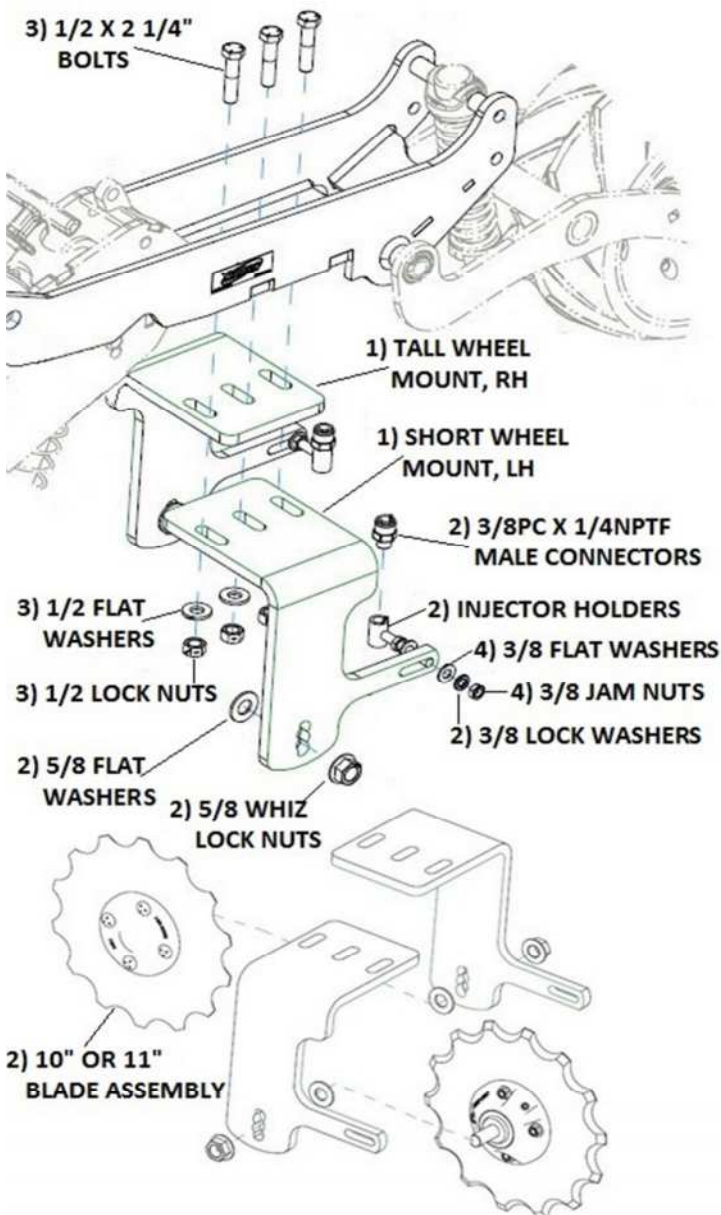

2968-051-R

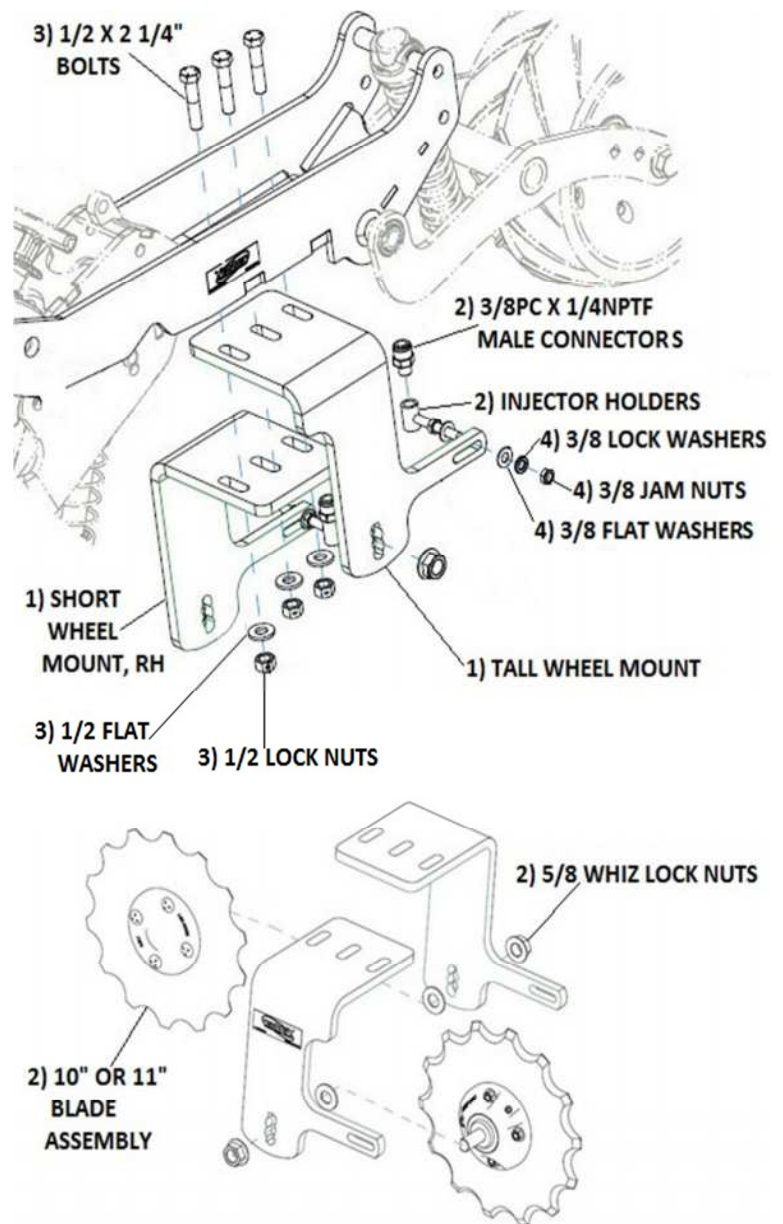

2968-053 INSTALLATION INSTRUCTIONS

DUAL DISC PLACEMENT

Step 3: Install the LH & RH 2968 arms to the main mount bracket using 3) 1/2 X 2 1/2 carriage bolts, 3) 1/2 flat washers, & 3) 1/2 lock nuts. Install each wheel assembly by placing a 5/8 flat washer over the D-Bolt, slide the D-Bolt through the hole to set the depth of the blade (see page 16 for depth chart), & install a 5/8 whiz lock nut. Install the injector holder by threading 1) 3/8 jam nut approximately 2" onto the threads. Place a 3/8 flat washer on the threads & slide the threads through the horizontally slotted hole. Place a 3/8 flat washer over the threads, followed by a 3/8 lock washer, & thread a 2nd 3/8 nut on the threads. Adjust the injector holder to be centered behind the blade & fasten in place. Install the male connector on the top of the injector holder.

NOTE: IF INSTALLING THE REAR KNIFE ASSEMBLIES INSTEAD OF INJECTOR HOLDERS, SEE THE REAR KNIFE MANUAL

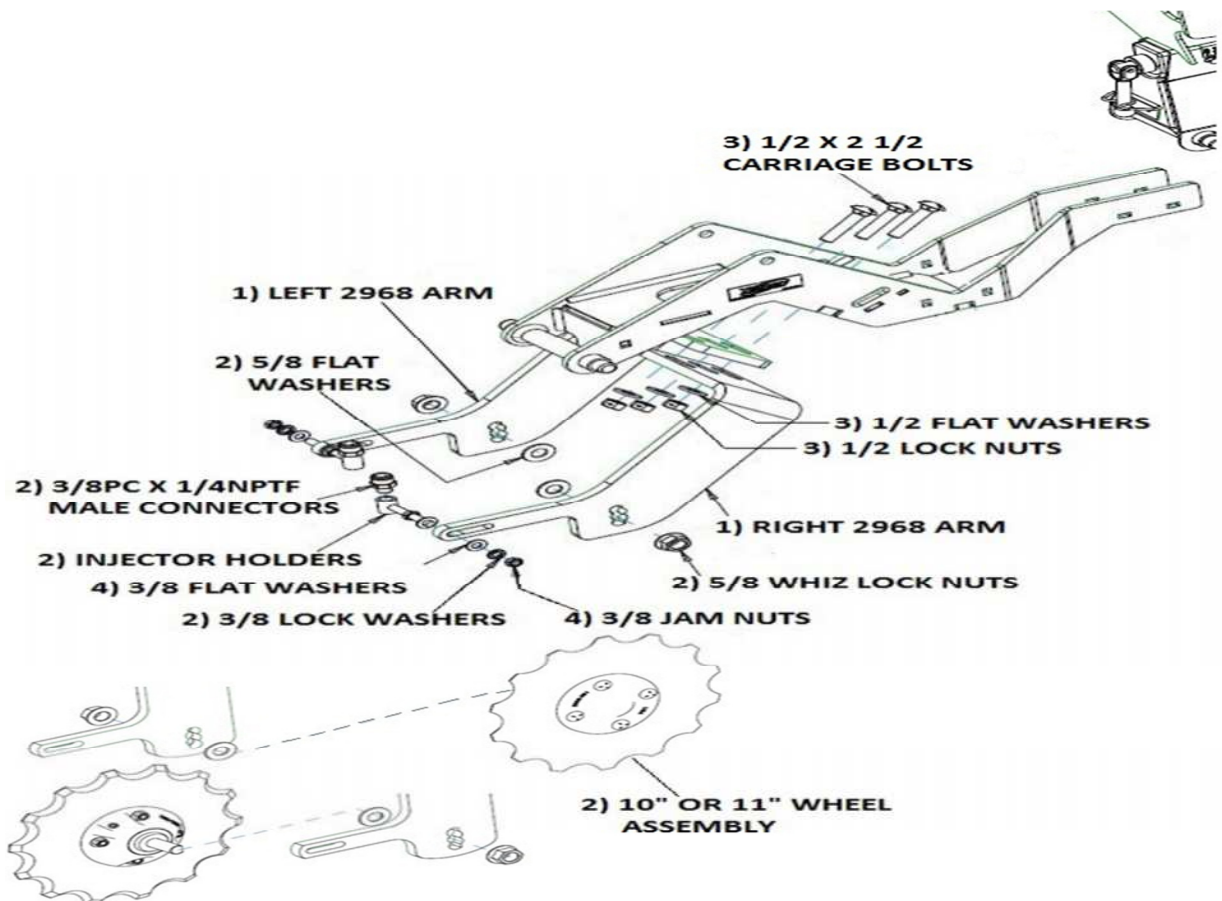

INJECTOR INSTALLATION & ALIGNMENT

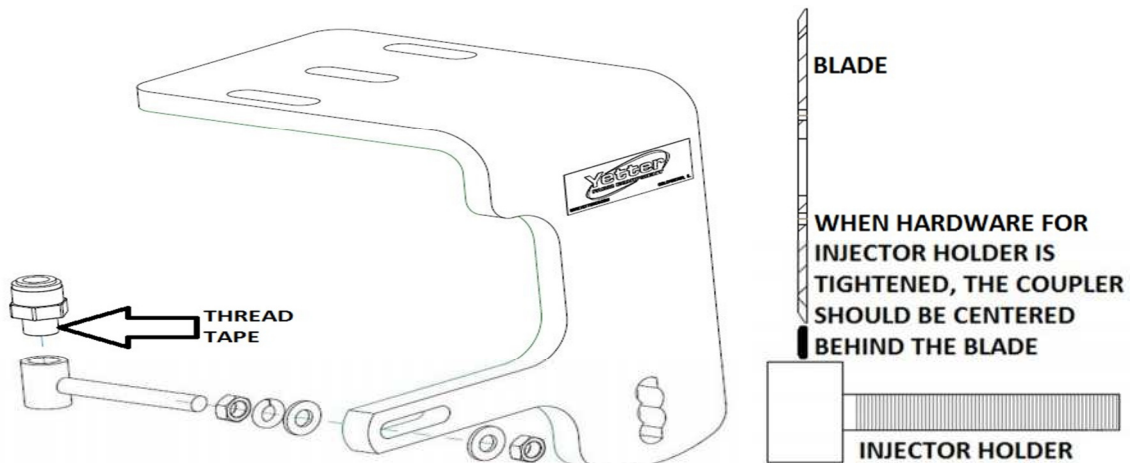

INSTALLATION INSTRUCTIONS

STEP 9: Assemble nozzle tip (not supplied) to each 2968-218 injector holder. Injector tips can be ordered through fertilizer equipment dealer. Calibrate the fertilizer pump and tips to **maximum recommended pressure of 30PSI and minimum 20PSI at the tip**. Attach the fertilizer hose to the top side of each coupler.

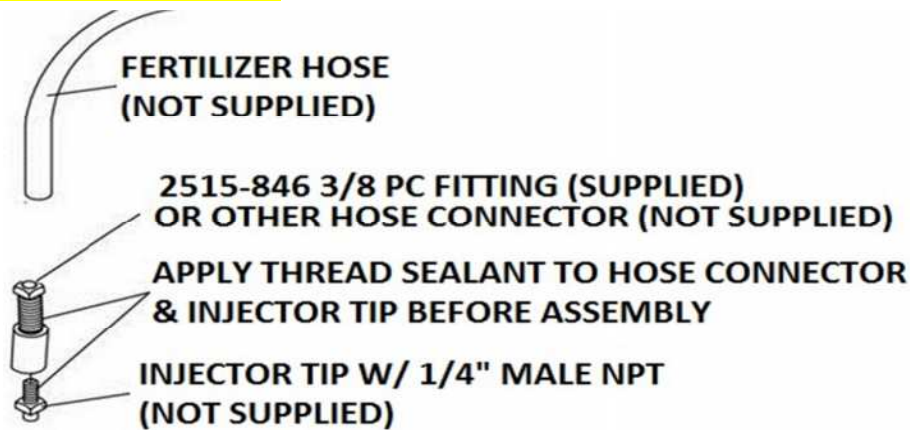

OPERATION

FERTILIZER WHEEL MOUNT BRACKET

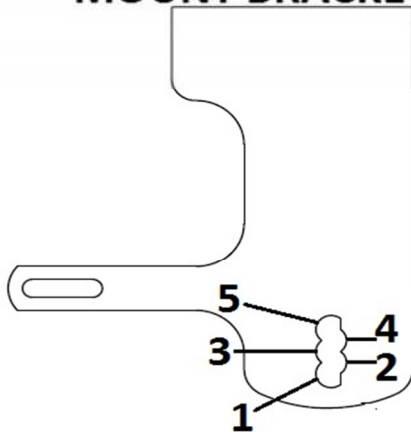

- On dual fertilizer placement, the wheels are staggered front to back to keep the soil from heaving.
- Fertilizer can be placed 2" – 3" off the seed furrow. Please see your agronomist to determine best spacing on the rate that's being applied.
- Calibrate the fertilizer pump and tips to **maximum pressure of 30PSI and minimum 20PSI at the tip**.
- Residue managers are recommended if residue in planting conditions to eliminate hair pinning.
- Blade replacement is necessary when the depth cannot be achieved or the blade struggles to penetrate the ground.
- If there is buildup of damp soil on the planter gauge wheels or opener disks, then conditions are less than ideal & some problems may also be encountered with the fertilizer wheel.
- Seed depth will need rechecked after fertilizer unit installation.
- More row unit down force will be needed to maintain fertilizer wheel depth.

<u>POSITION</u>	<u>DEPTH (USING 10" NOTCHED BLADE)</u>
1	3/4" BELOW DOUBLE DISC OPENERS
2	1/2" BELOW DOUBLE DISC OPENERS
3	1/4" BELOW DOUBLE DISC OPENERS
4	EVEN WITH DOUBLE DISC OPENERS
5	1/4" ABOVE DOUBLE DISC OPENERS

<u>POSITION</u>	<u>DEPTH (USING 11" NOTCHED BLADE)</u>
1	1 1/4" BELOW DOUBLE DISC OPENERS
2	1" BELOW DOUBLE DISC OPENERS
3	3/4" BELOW DOUBLE DISC OPENERS
4	1/2" BELOW DOUBLE DISC OPENERS
5	1/4" BELOW DOUBLE DISC OPENERS

OPERATION

LIQUID FERTILIZER APPLICATION RATE & PRESSURE CHART – TABLES BASED ON 30” NOZZLE SPACING

TIP #	LIQUID PRESSURE IN PSI	CAPACITY 1 NOZZLE IN GPM	GALLONS PER ACRE (USING WATER)					
			4 MPH H2O	5 MPH H2O	5.5 MPH H2O	6 MPH H2O	7 MPH H2O	8MPH H2O
#00015	20	0.11	5.45	4.36	3.96	3.63	3.11	2.72
	25	0.12	5.94	4.75	4.32	3.96	3.39	2.97
	30	0.13	6.44	5.15	4.68	4.29	3.68	3.22
	40	0.15	7.43	5.94	5.40	4.95	4.24	3.71
	50	0.17	8.42	6.73	6.12	5.61	4.81	4.21
	60	0.18	8.91	7.13	6.48	5.94	5.09	4.46
#0002	20	0.14	6.93	5.54	5.04	4.62	3.96	3.47
	25	0.16	7.92	6.34	5.76	5.28	4.53	3.96
	30	0.17	8.42	6.73	6.12	5.61	4.81	4.21
	40	0.20	9.90	7.92	7.20	6.60	5.66	4.95
	50	0.23	11.39	9.11	8.28	7.59	6.51	5.69
	60	0.25	12.38	9.90	9.00	8.25	7.07	6.19
#0003	20	0.21	10.40	8.32	7.56	6.93	5.94	5.20
	25	0.24	11.88	9.50	8.64	7.92	6.79	5.94
	30	0.26	12.87	10.30	9.36	8.58	7.35	6.44
	40	0.30	14.85	11.88	10.80	9.90	8.49	7.43
	50	0.34	16.83	13.46	12.24	11.22	9.62	8.42
	60	0.37	18.32	14.65	13.32	12.21	10.47	9.16
#0004	20	0.28	13.86	11.09	10.08	9.24	7.92	6.93
	25	0.32	15.84	12.67	11.52	10.56	9.05	7.92
	30	0.35	17.33	13.86	12.60	11.55	9.90	8.66
	40	0.40	19.80	15.84	14.40	13.20	11.31	9.90
	50	0.45	22.28	17.82	16.20	14.85	12.73	11.14
	60	0.49	24.26	19.40	17.64	16.17	13.86	12.13
#0005	20	0.35	17.33	13.86	12.60	11.55	9.90	8.66
	25	0.40	19.80	15.84	14.40	13.20	11.31	9.90
	30	0.43	21.29	17.03	15.48	14.19	12.16	10.64
	40	0.50	24.75	19.80	18.00	16.50	14.14	12.38
	50	0.56	27.72	22.18	20.16	18.48	15.84	13.86
	60	0.61	30.20	24.16	21.96	20.13	17.25	15.10
#0006	20	0.42	20.79	16.63	15.12	13.86	11.88	10.40
	25	0.47	23.27	18.61	16.92	15.51	13.29	11.63
	30	0.52	25.74	20.59	18.72	17.16	14.71	12.87
	40	0.60	29.70	23.76	21.60	19.80	16.97	14.85
	50	0.67	33.17	26.53	24.12	22.11	18.95	16.58
	60	0.74	36.63	29.30	26.364	24.42	20.93	18.32
#0008	20	0.57	28.22	22.57	20.52	18.81	16.12	14.11
	25	0.63	31.19	24.95	22.68	20.79	17.82	15.59
	30	0.69	34.16	27.32	24.84	22.77	19.52	17.08
	40	0.80	39.60	31.68	28.80	26.40	22.63	19.80
	50	0.89	44.06	35.24	32.04	29.37	25.17	22.03
	60	0.98	48.51	38.81	35.28	32.34	27.72	24.26
#0010	20	0.71	35.15	28.12	25.56	23.43	20.08	17.57
	25	0.79	39.11	31.28	28.44	26.07	22.35	19.55
	30	0.87	43.07	34.45	31.32	28.71	24.61	21.53
	40	1.00	49.50	39.60	36.00	33.00	28.29	24.75
	50	1.12	55.44	44.35	40.32	36.96	31.68	27.72
	60	1.23	60.89	48.71	44.28	40.59	34.79	30.44
#0015	20	1.06	52.47	41.98	38.16	34.98	29.98	26.24
	25	1.19	58.91	47.12	42.84	39.27	33.66	29.45
	30	1.30	64.35	51.48	46.80	42.90	36.77	32.18
	40	1.50	74.25	59.40	54.00	49.50	42.43	37.13
	50	1.68	83.16	66.53	60.48	55.44	47.52	41.58
	60	1.81	89.60	71.68	65.16	59.73	51.20	44.80

Row Spacing Multiplier	10" X 3.3	15" X 2.0	20" X 1.5	36" X .83	38" X .79	40" X .75
------------------------	-----------	-----------	-----------	-----------	-----------	-----------

Values in this chart area based on using water. To calculate nozzle size required for your fertilizer application, the weight of the fertilizer solution must be accounted for by using a conversion factor for specific gravity. The Conversion factor for 28% liquid nitrogen is 1.13. Example: desired rate of application is 10 GPA of 28% N multiply 10 gallons per acre of fertilizer you want to apply x the conversion factor for 28% N (1.13) to get an equivalent rate for water. 10 x 1.13 refers to the chart for 11.13 gallons per acre at your desired speed/MPH.

GPA = $\frac{5940 \times \text{GPM}}{\text{MPH} \times \text{W}}$
 (Per Nozzle)

H2O = WATER
GPA = GALLON PER ACRE
GPM = GALLON PER MINUTES
MPH = MILES PER HOUR
W = WIDTH

SOLUTION
28% = H2O/1.13
32% = H2O/1.15

This table is a reference only. Please calibrate your equipment to insure proper rate of application.

The information contained in this issue is offered in good faith by Yetter Mfg. Co. to further the understanding of liquid fertilizer application.

However, the use of the information provided is beyond the control of Yetter Mfg. Co. and in no case shall Yetter Mfg. Co. or any seller of its products be responsible for any damages that may occur from the use of this information.

MAINTENANCE

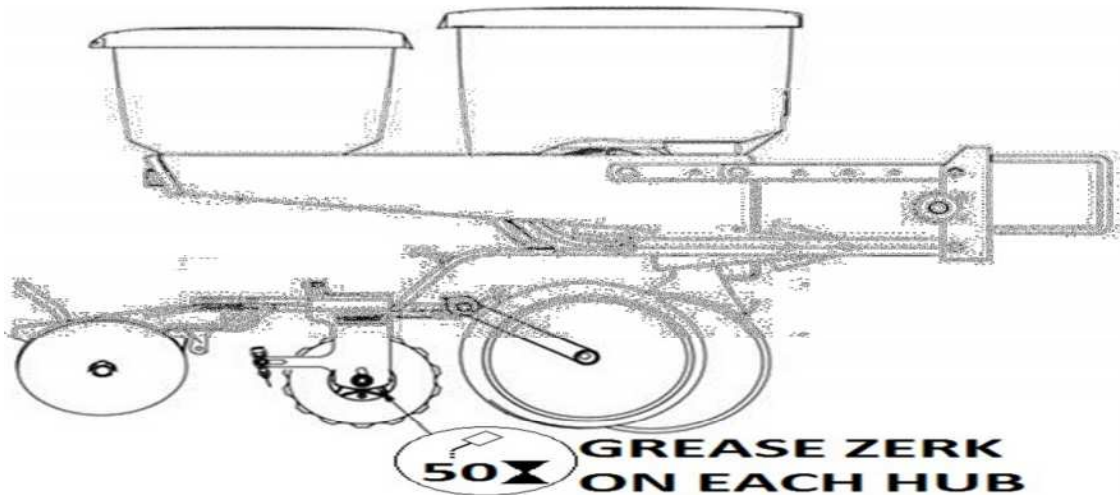

IMPORTANT: If seal is removed from hub/bearing assembly, grease bearing Every 50 hours. If seal is left assembled, 2-3 pumps of grease twice a year, depending on acres, is sufficient.



IMPORTANT: For proper operation, the planter frame must operate level (fore, aft & side to side) and at the correct height, typically 20"-22".

Regularly inspect the residue manager for loose or worn parts. Repair and replace as needed.

BEARING ASSEMBLY AND LUBRICATION

Practice Safety

Understand and practice safe service procedures before doing work. Follow ALL the operating, maintenance and safety information in the equipment operator manual. Clear the area of bystanders, especially small children, when performing any maintenance or adjustments. Keep work area clean and dry. Use adequate lighting for the job. Use only tools, jacks and hoists of sufficient capacity for the job.

Never lubricate, service, or adjust machine while it is moving. Keep hands, feet, and clothing from power-driven moving and rotating parts. Disengage all power and operate controls to relieve pressure. Lower equipment to the ground and stop the engine. Remove the key. Wait for all moving parts to stop before servicing, adjusting, repairing or unplugging.

Securely support any machine elements with blocks or safety stands that must be raised for service work.

Keep all parts in good condition and properly installed. Fix damaged equipment immediately.

Replace worn or broken parts. Remove any buildup of grease, oil, or debris.

Make sure all guards are in place and properly secured when maintenance work is completed.

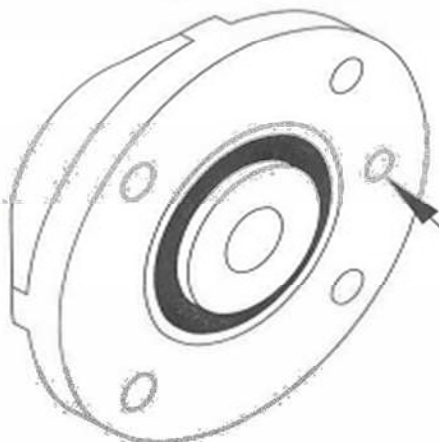

ALIGN GREASE FITTING HOLES.

MAINTENANCE

ALIGN THE HUB CAP GROOVE WITH THE WHEEL SLOT & GREASE FITTING

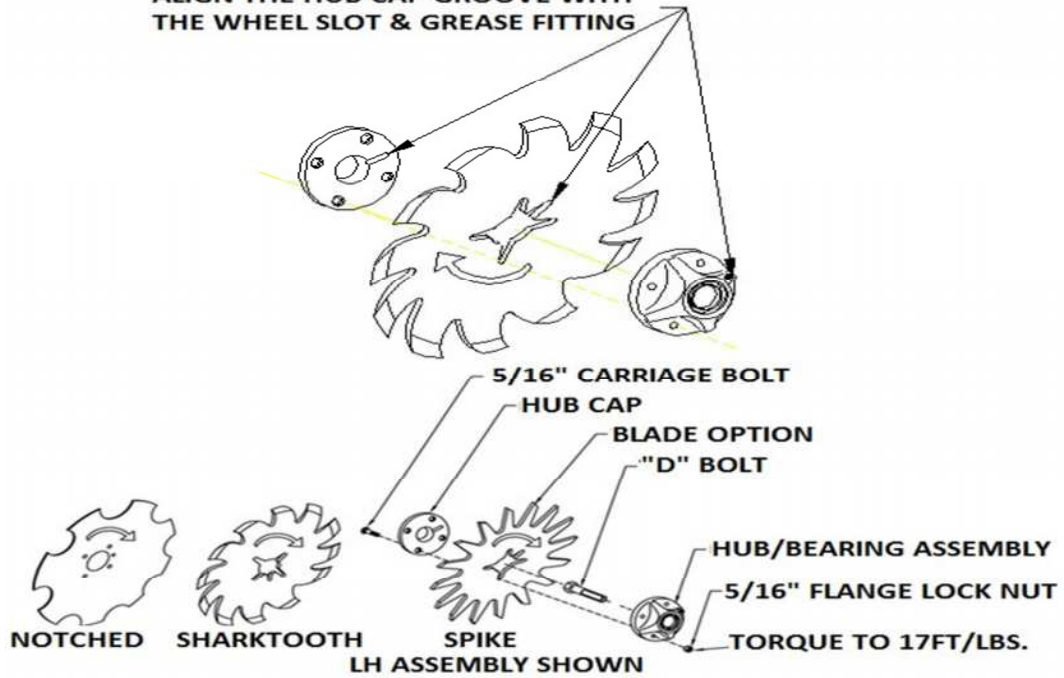

NOTE: BE CERTAIN TO ALIGN THE GREASE FITTING WITH THE SLOT IN THE WHEEL & HUBCAP SO THAT THE GREASE CAN FLOW FREELY.

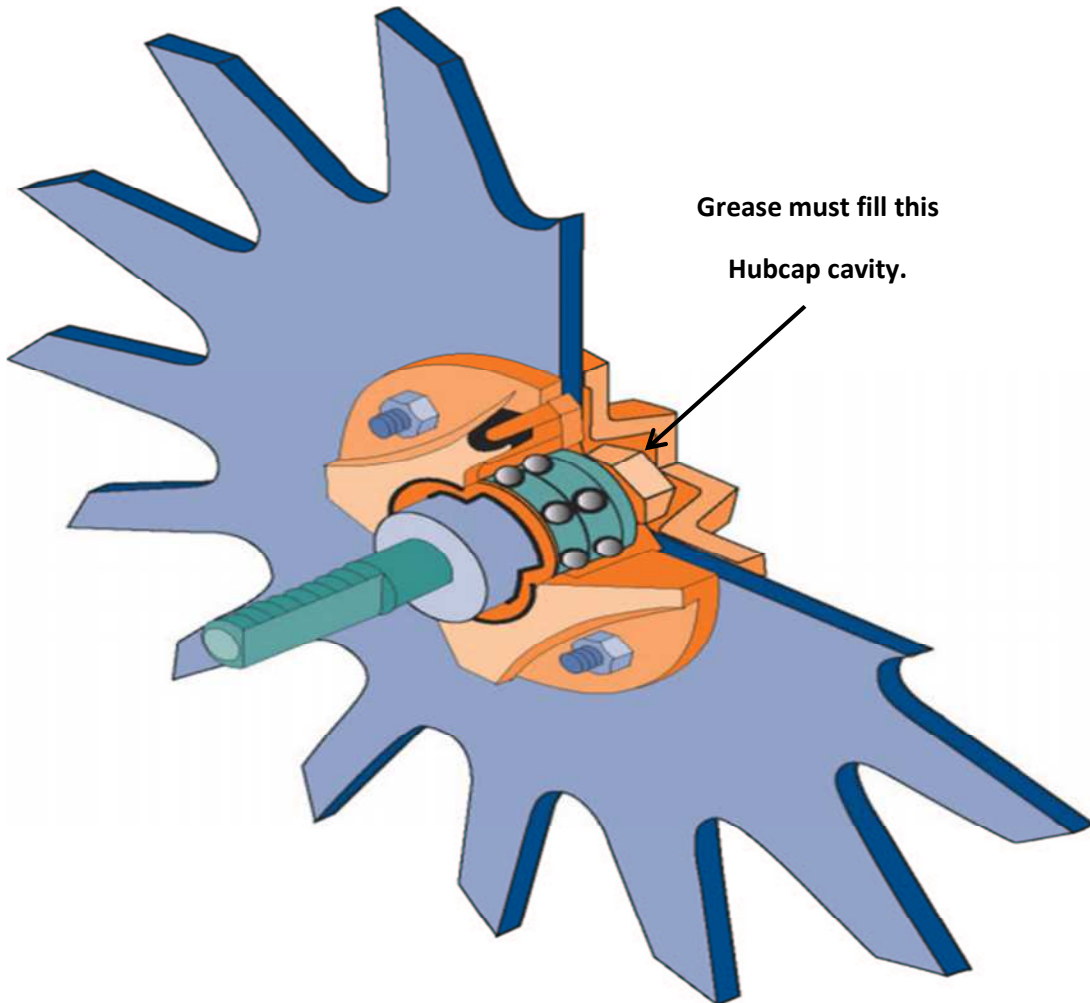

MAINTENANCE

CAUTION: To help prevent serious injury/death to you or others caused by unexpected movement, service machine on a level surface. Lower machine to ground or sufficiently lock or block raised machine before servicing. If machine is connected to tractor, engage parking brake & place transmission in "PARK", shut off engine, & remove key. If machine is detached from tractor, block wheels & use shop stands to prevent movement.



CAUTION: DO NOT CLEAN, LUBRICATE, OR ADJUST MACHINE WHILE IN MOTION

Use grease based on NLGI consistency numbers & the expected air temperature range during the service interval. Use a **multi-purpose polyurea, water resistant, moderate speed, & NLGI grade #2** grease. Other greases may be used if they meet the following **NLGI Performance**.

IMPORTANT: Some types of grease thickener are not compatible with others. Consult your grease supplier before mixing different types of greases.

Alternative Lubricants

Conditions in certain geographical areas may require special lubricants & lubrication practices which do not appear in the operator's manual. If there are any questions, consult Yetter Manufacturing Co. to obtain latest information & recommendation.

PART #	DESCRIPTION	OUNCES OF GREASE
2968-320	10" FERTILIZER WHEEL	1.12 OZ
2968-364	11" FERTILIZER WHEEL	1.12 OZ

Storing Lubricants

Your machine can operate at top efficiency only if clean lubricants are used. Use clean containers to handle all lubricants. **Store them in an area protected from dust, moisture and other contaminants**

LUBRICATION SYMBOLS

Lubricate with grease at hourly interval indicated on symbol if seal has been removed. If seal is left installed on hub/bearing assembly, apply 2 – 3 pumps of grease to each hub twice a season to keep cavity full.

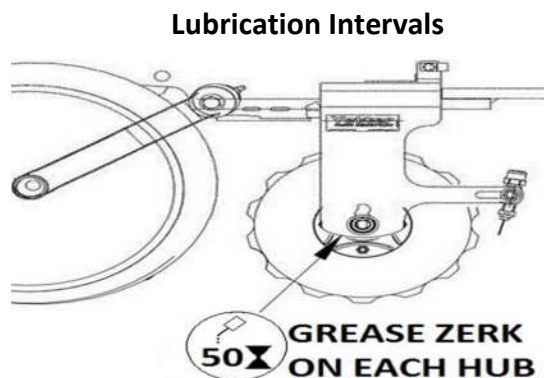

IMPORTANT: The recommended service intervals are based on normal conditions; severe or unusual conditions may require more frequent lubrication. Perform each lubrication and service procedure at the beginning & end of each season. Clean grease fittings before using grease gun, to avoid injecting dirt & grit into the bearing. Replace any lost or broken fittings immediately. If a fitting fails to take grease, remove & clean thoroughly, replace fitting if necessary. Also check for failure of adjoining parts.

BEARING REPLACEMENT INSTALLATION

1. When assembling the spoke wheels, bearing assembly and hubcap, be sure to align the grease transfer hole in the spoke wheel with the groove in the hubcap and hole in the hub to allow grease passage.
2. Assemble the wheels, hubs and caps.
3. Grease the wheel/hub/bearing assembly.

2968-050-L PART IDENTIFICATION

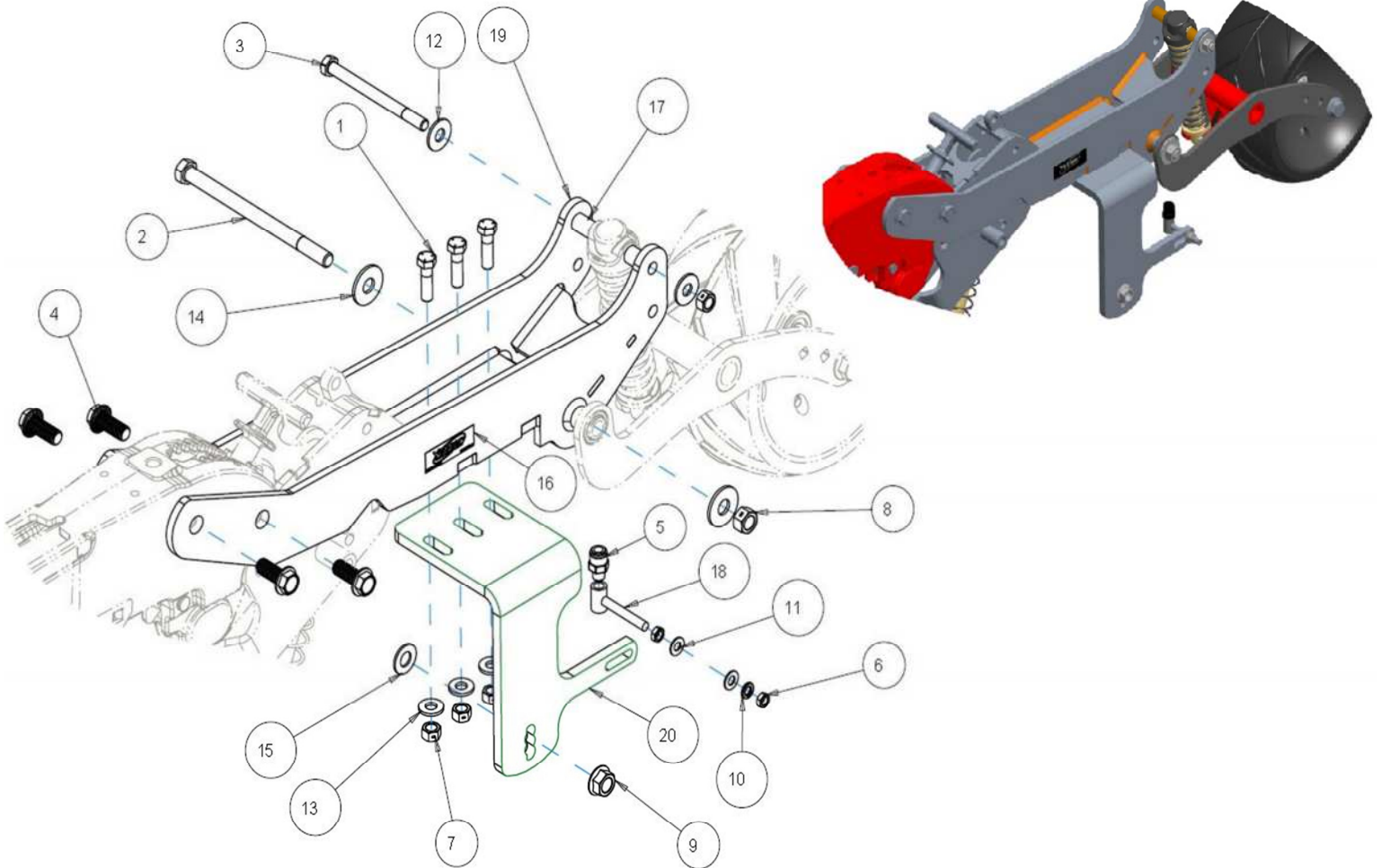

ITEM	PART #	DESCRIPTION	QTY
1	2502-317	½ - 13 X 1 ¾ HHCS GR 5 ZP	3
2	2502-333	5/8 – 11 X 9 HHCS GR 5 ZP	1
3	2502-373	½ - 13 X 6 HHCS GR 5 ZP	1
4	2502-808	M16 X 40 SERRATED HEX FLANGE BOLT ZP	4
5	2515-846	MALE CONNECTOR – 3/8PC X 1/4NPTF	1
6	2520-253	3/8 – 16 JAM HEX NUT ZP	2
7	2520-357	½ - 13 LOCK HEX NUT GR A ZP	4
8	2520-459	5/8 – 11 LOCK HEX NUT GR B ZP	1
9	2520-464	5/8 – 11 WHIZLOCK HEX NUT GR 2 ZP	1
10	2525-251	3/8 MEDIUM LOCK WASHER ZP	1
11	2526-253	3/8 SAE FLAT WASHER ZP	2
12	2526-351	½ STANDARD FLAT WASHER ZP	2
13	2526-355	½ FLAT WASHER HARDENED ZP	3
14	2526-451	5/8 STANDARD FLAT WASHER ZP	2
15	2526-454	5/8 SAE FLAT WASHER HARDENED ZP	1
16	2565-179	YETTER DECAL	2
17	2967-567	PIVOT BUSHING ZP	2
18	2968-218	INJECTOR HOLDER W.A.	1
19	2968-227	2968 MOUNT ASSEMBLY, CASE 2150	1
20	2968-359-LH	SHORT FETILIZER WHEEL MOUNT, LH	1

2968-050-R PART IDENTIFICATION

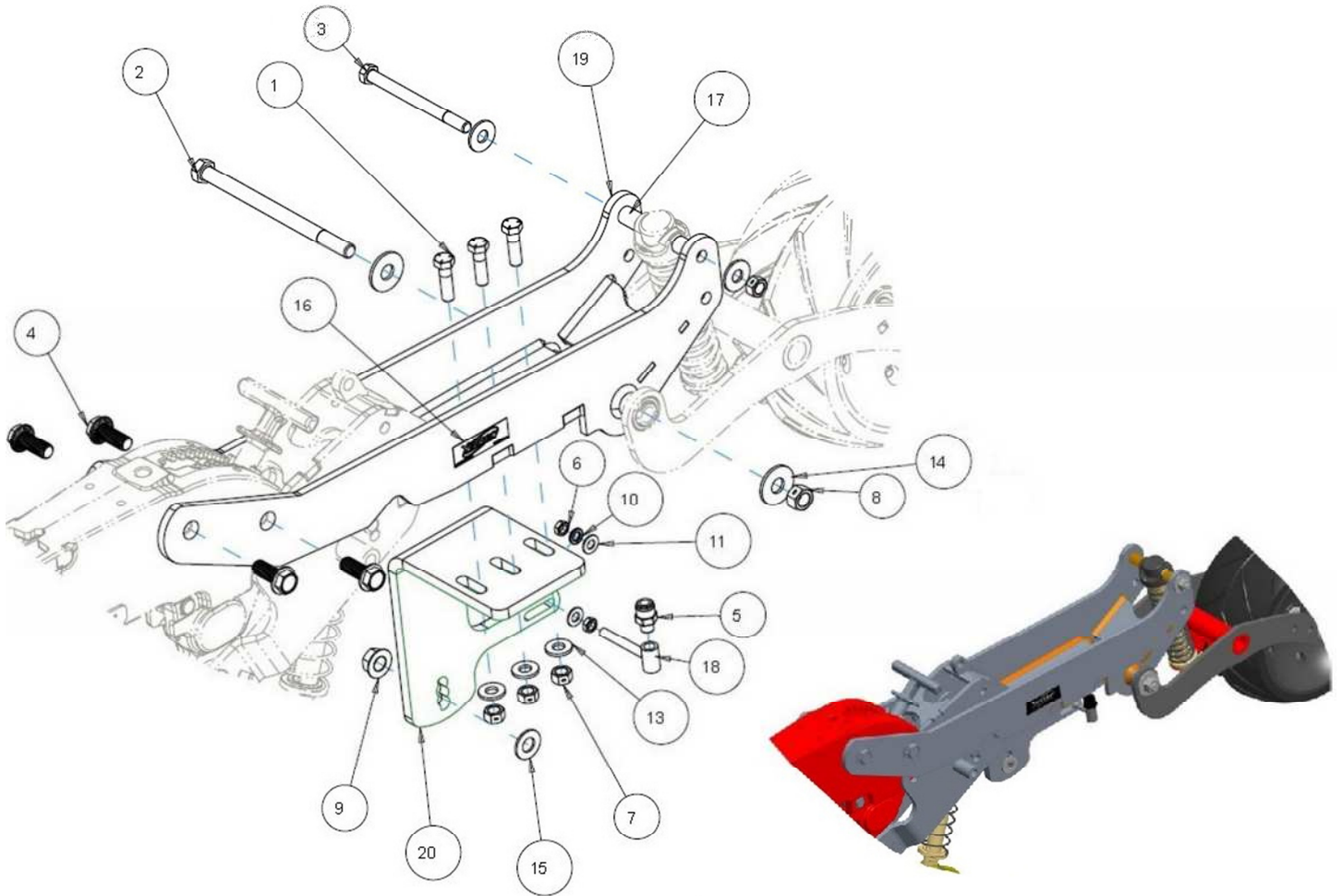

ITEM	PART #	DESCRIPTION	QTY
1	2502-317	½ - 13 X 1 ¾ HHCS GR 5 ZP	3
2	2502-333	5/8 – 11 X 9 HHCS GR 5 ZP	1
3	2502-373	½ - 13 X 6 HHCS GR 5 ZP	1
4	2502-808	M16 X 40 SERRATED HEX FLANGE BOLT ZP	4
5	2515-846	MALE CONNECTOR – 3/8PC X 1/4NPTF	1
6	2520-253	3/8 – 16 JAM HEX NUT ZP	2
7	2520-357	½ - 13 LOCK HEX NUT GR A ZP	4
8	2520-459	5/8 – 11 LOCK HEX NUT GR B ZP	1
9	2520-464	5/8 – 11 WHIZLOCK HEX NUT GR 2 ZP	1
10	2525-251	3/8 MEDIUM LOCK WASHER ZP	1
11	2526-253	3/8 SAE FLAT WASHER ZP	2
12	2526-351	½ STANDARD FLAT WASHER ZP	2
13	2526-355	½ FLAT WASHER HARDENED ZP	3
14	2526-451	5/8 STANDARD FLAT WASHER ZP	2
15	2526-454	5/8 SAE FLAT WASHER HARDENED ZP	1
16	2565-179	YETTER DECAL	2
17	2967-567	PIVOT BUSHING ZP	2
18	2968-218	INJECTOR HOLDER W.A.	1
19	2968-227	2968 MOUNT ASSEMBLY, CASE 2150	1
20	2968-359-RH	SHORT FERTILIZER WHEEL MOUNT, RH	1

2968-051-L PART IDENTIFICATION

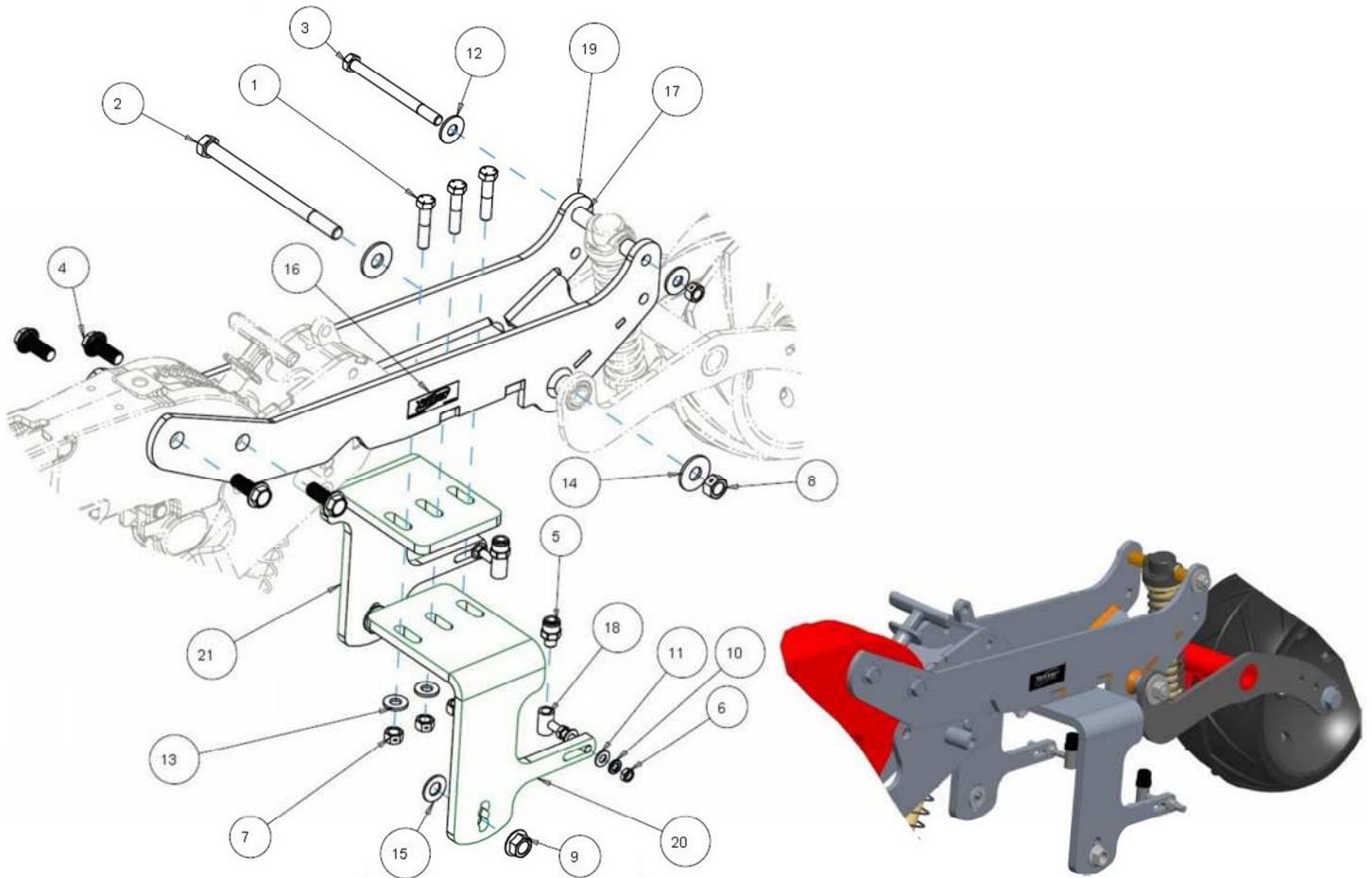

ITEM	PART #	DESCRIPTION	QTY
1	2502-314	½ - 13 X 2 ¼ HHCS GR 5 ZP	3
2	2502-333	5/8 - 11 X 9 HHCS GR 5 ZP	1
3	2502-373	½ - 13 X 6 HHCS GR 5 ZP	1
4	2502-808	M16 X 40 SERRATED HEX FLANGE BOLT ZP	4
5	2515-846	MALE CONNECTOR - 3/8PC X 1/4NPTF	2
6	2520-253	3/8 - 16 JAM HEX NUT ZP	4
7	2520-357	½ - 13 LOCK HEX NUT GR A ZP	4
8	2520-459	5/8 - 11 LOCK HEX NUT GR B ZP	1
9	2520-464	5/8 - 11 WHIZLOCK HEX NUT GR 2 ZP	2
10	2525-251	3/8 MEDIUM LOCK WASHER ZP	2
11	2526-253	3/8 SAE FLAT WASHER ZP	4
12	2526-351	½ STANDARD FLAT WASHER ZP	2
13	2526-355	½ FLAT WASHER HARDENED ZP	3
14	2526-451	5/8 STANDARD FLAT WASHER ZP	2
15	2526-454	5/8 SAE FLAT WASHER HARDENED ZP	2
16	2565-179	YETTER DECAL	2
17	2967-567	PIVOT BUSHING ZP	2
18	2968-218	INJECTOR HOLDER W.A.	2
19	2968-227	2968 MOUNT ASSEMBLY, CASE 2150	1
20	2968-359-LH	SHORT FETILIZER WHEEL MOUNT, LH	1
21	2968-360-RH	TALL WHEEL MOUNT, RH	1

2968-051-R PART IDENTIFICATION

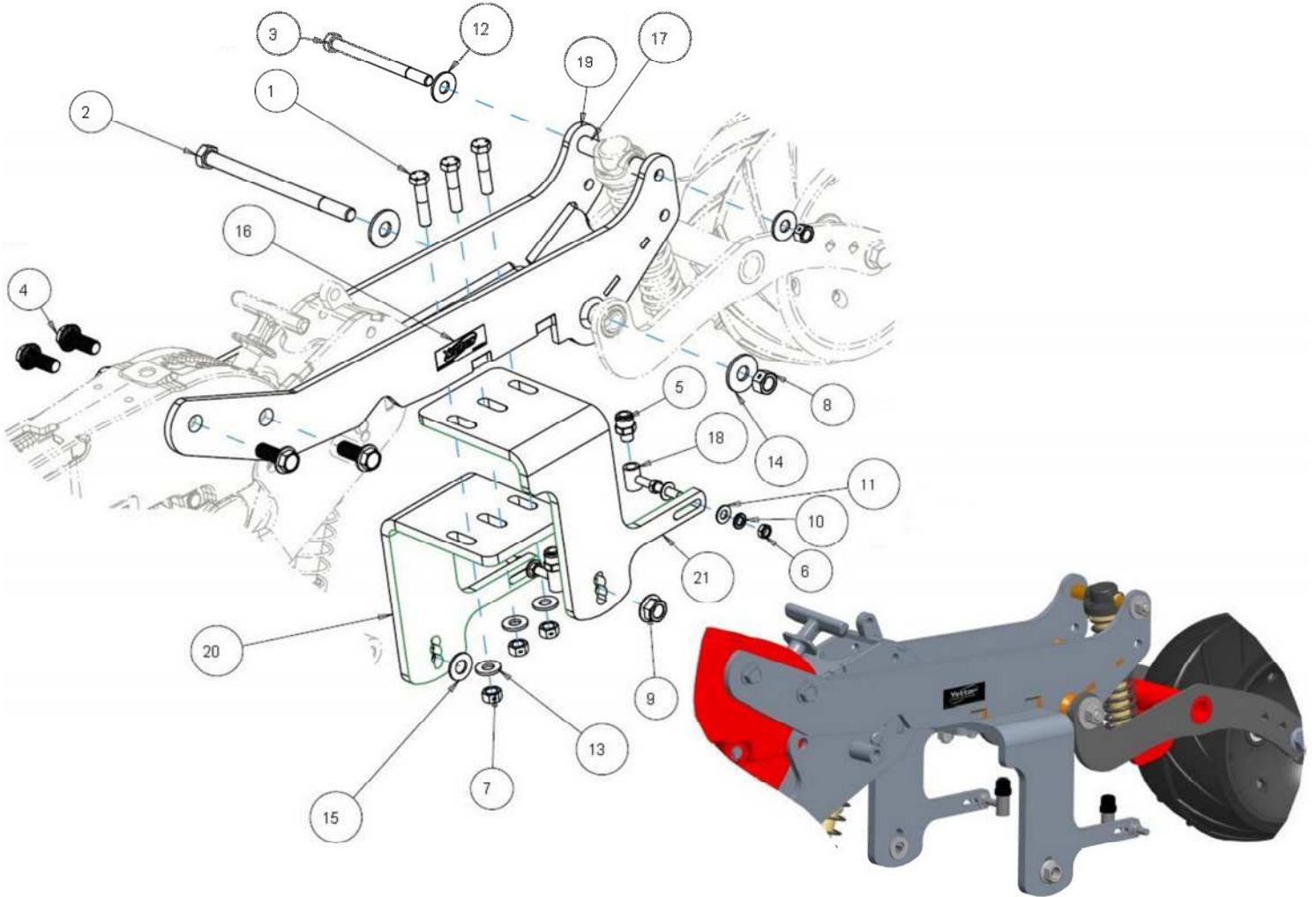

ITEM	PART #	DESCRIPTION	QTY
1	2502-314	½ - 13 X 2 ¼ HHCS GR 5 ZP	3
2	2502-333	5/8 - 11 X 9 HHCS GR 5 ZP	1
3	2502-373	½ - 13 X 6 HHCS GR 5 ZP	1
4	2502-808	M16 X 40 SERRATED HEX FLANGE BOLT ZP	4
5	2515-846	MALE CONNECTOR - 3/8PC X 1/4NPTF	2
6	2520-253	3/8 - 16 JAM HEX NUT ZP	4
7	2520-357	½ - 13 LOCK HEX NUT GR A ZP	4
8	2520-459	5/8 - 11 LOCK HEX NUT GR B ZP	1
9	2520-464	5/8 - 11 WHIZLOCK HEX NUT GR 2 ZP	2
10	2525-251	3/8 MEDIUM LOCK WASHER ZP	2
11	2526-253	3/8 SAE FLAT WASHER ZP	4
12	2526-351	½ STANDARD FLAT WASHER ZP	2
13	2526-355	½ FLAT WASHER HARDENED ZP	3
14	2526-451	5/8 STANDARD FLAT WASHER ZP	2
15	2526-454	5/8 SAE FLAT WASHER HARDENED ZP	2
16	2565-179	YETTER DECAL	2
17	2967-567	PIVOT BUSHING ZP	2
18	2968-218	INJECTOR HOLDER W.A.	2
19	2968-227	2968 MOUNT ASSEMBLY, CASE 2150	1
20	2968-359-RH	SHORT FERTILIZER WHEEL MOUNT, RH	1
21	2968-360	TALL FERTILIZER WHEEL MOUNT	1

2968-052-L PART IDENTIFICATION

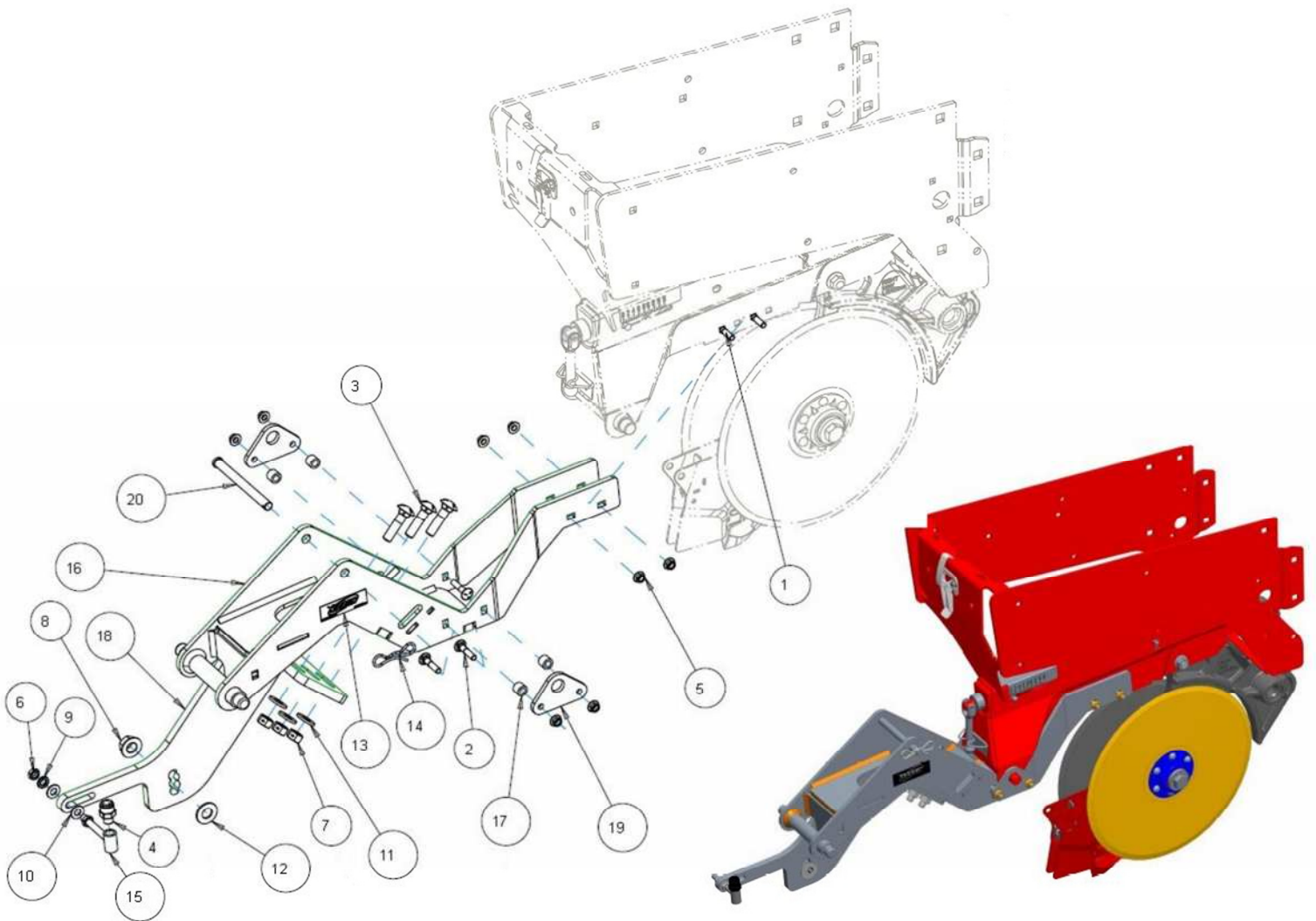

ITEM	PART #	DESCRIPTION	QTY
1	2505-207	5/16 – 18 X 1 ¼ CARRIAGE BOLT GR 5 ZP	4
2	2505-208	5/16 – 18 X 1 ½ CARRIAGE BOLT GR 5 ZP	4
3	2505-345	½ - 13 X 2 CARRIAGE BOLT GR 5 ZP	3
4	2515-846	MALE CONNECTOR, 3/8 PC X 1/4NPTF	1
5	2520-206	5/16 – 18 FLANGE LOCK NUT	8
6	2520-253	5/16 – 18 JAM HEX NUT ZP	2
7	2520-357	½ - 13 LOCK HEX NUT GR A ZP	3
8	2520-464	5/8 – 11 WHIZLOCK HEX NUT GR 2 ZP	1
9	2525-251	3/8 MEDIUM LOCK WASHER ZP	1
10	2526-253	3/8 SAE FLAT WASHER ZP	1
11	2526-355	½ FLAT WASHER HARDENED ZP	3
12	2526-454	5/8 SAE FLAT WASHER HARDENED ZP	1
13	2565-179	YETTER DECAL	2
14	2570-448	.120 BOWTIE LOCKING COTTER ZP	1
15	2968-218	INJECTOR HOLDER W.A.	1
16	2968-226	MAIN MOUNT BRACKET W.A.	1
17	2968-383	TRIANGULAR MOUNT SPACER, ZP	4
18	2968-384	LEFT 2968 ARM	1
19	2968-386	TRIANGULAR MOUNT	2
20	2984-497	AIR CYLINDER ROD PIN	1

2968-052-R PART IDENTIFICATION

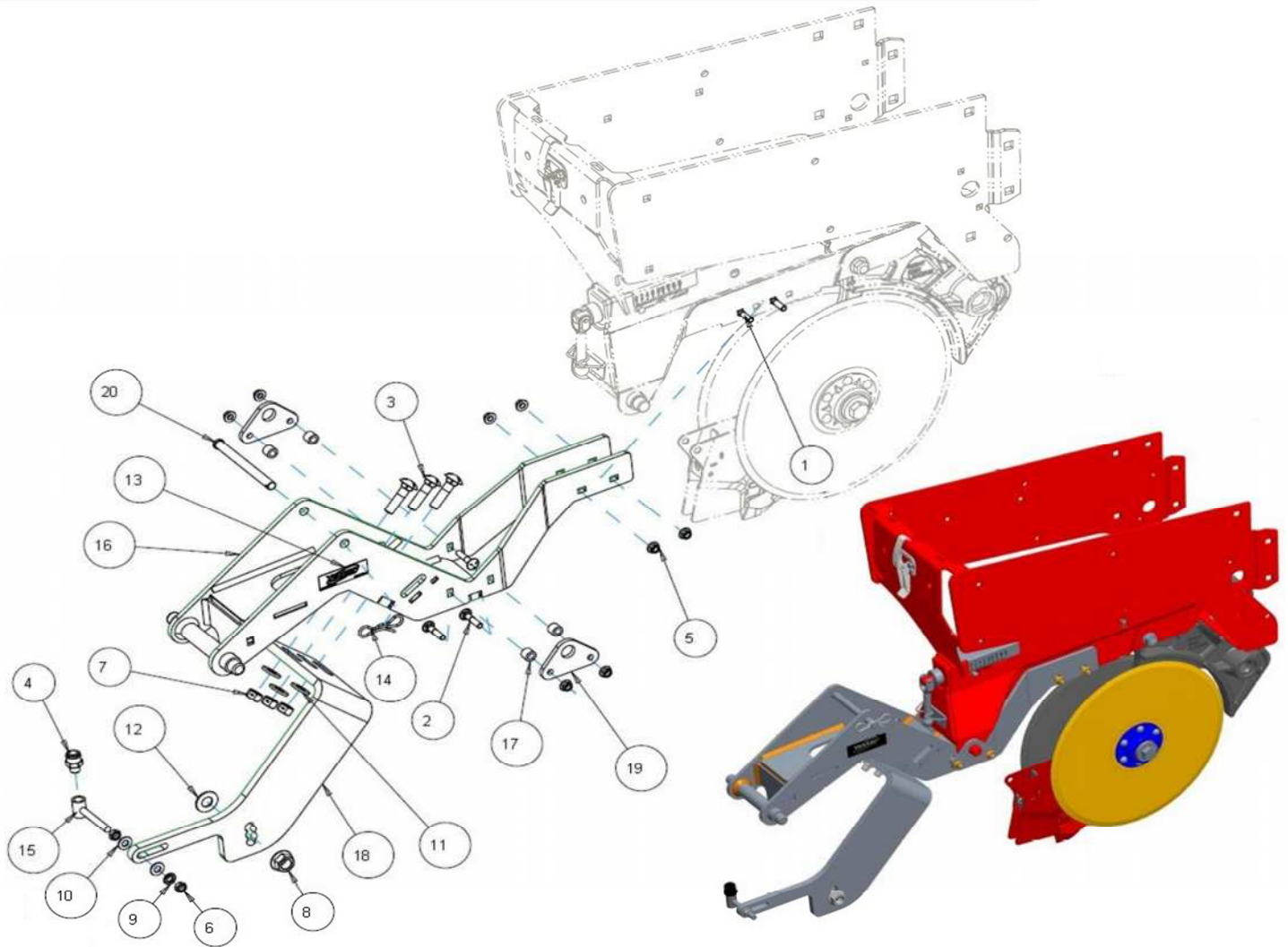

ITEM	PART #	DESCRIPTION	QTY
1	2505-207	5/16 – 18 X 1 ¼ CARRIAGE BOLT GR 5 ZP	4
2	2505-208	5/16 – 18 X 1 ½ CARRIAGE BOLT GR 5 ZP	4
3	2505-345	½ - 13 X 2 CARRIAGE BOLT GR 5 ZP	3
4	2515-846	MALE CONNECTOR, 3/8 PC X 1/4NPTF	1
5	2520-206	5/16 – 18 FLANGE LOCK NUT	8
6	2520-253	5/16 – 18 JAM HEX NUT ZP	2
7	2520-357	½ - 13 LOCK HEX NUT GR A ZP	3
8	2520-464	5/8 – 11 WHIZLOCK HEX NUT GR 2 ZP	1
9	2525-251	3/8 MEDIUM LOCK WASHER ZP	1
10	2526-253	3/8 SAE FLAT WASHER ZP	1
11	2526-355	½ FLAT WASHER HARDENED ZP	3
12	2526-454	5/8 SAE FLAT WASHER HARDENED ZP	1
13	2565-179	YETTER DECAL	2
14	2570-448	.120 BOWTIE LOCKING COTTER ZP	1
15	2968-218	INJECTOR HOLDER W.A.	1
16	2968-226	MAIN MOUNT BRACKET W.A.	1
17	2968-383	TRIANGULAR MOUNT SPACER, ZP	4
18	2968-385	RIGHT 2968 ARM	1
19	2968-386	TRIANGULAR MOUNT	2
20	2984-497	AIR CYLINDER ROD PIN	1

2968-053 PART IDENTIFICATION

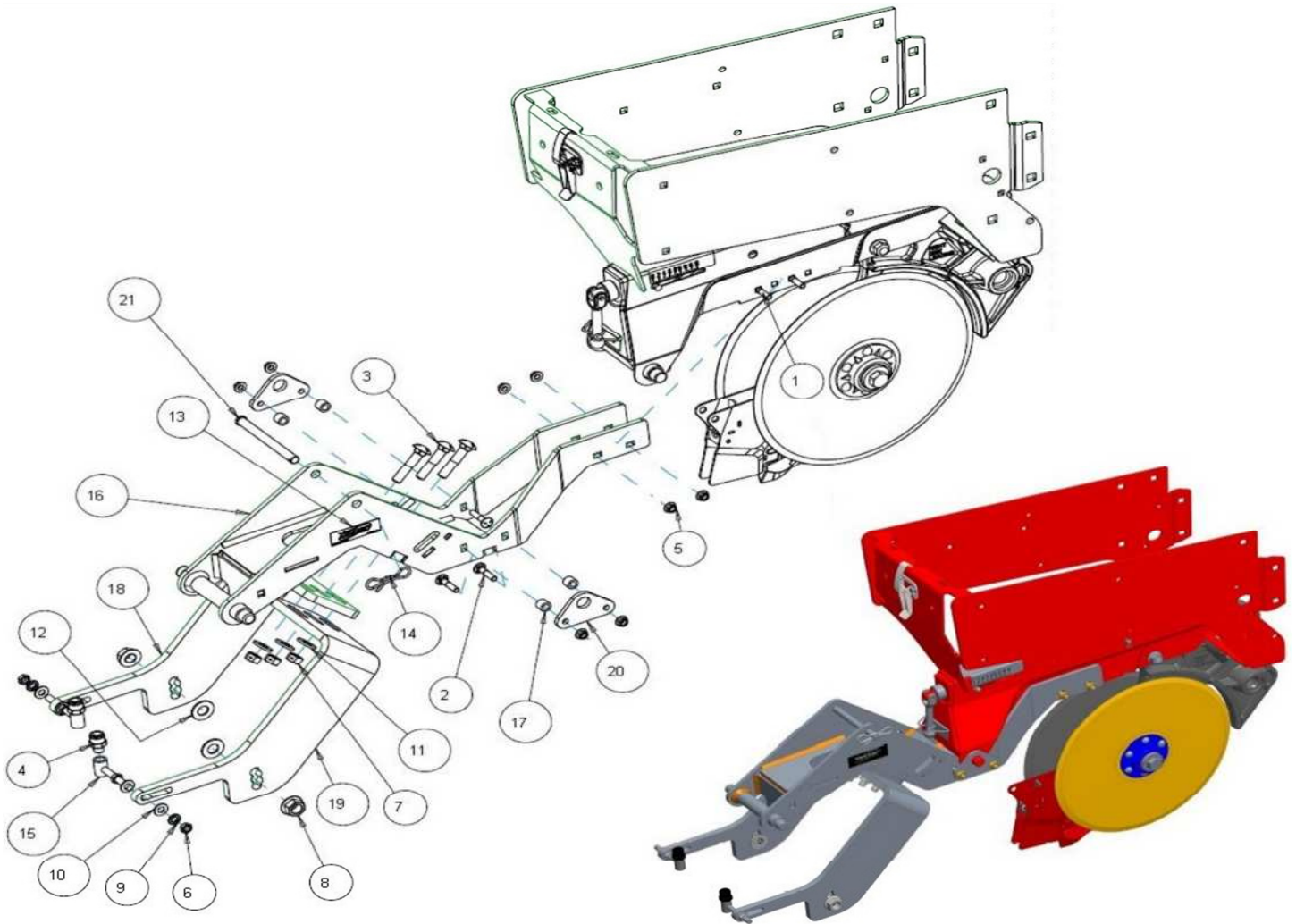

ITEM	PART #	DESCRIPTION	QTY
1	2505-207	5/16 – 18 X 1 ¼ CARRIAGE BOLT GR 5 ZP	4
2	2505-208	5/16 – 18 X 1 ½ CARRIAGE BOLT GR 5 ZP	4
3	2505-343	½ - 13 X 2 ½ CARRIAGE BOLT GR 5 ZP	3
4	2515-846	MALE CONNECTOR, 3/8 PC X 1/4NPTF	2
5	2520-206	5/16 – 18 FLANGE LOCK NUT	8
6	2520-253	5/16 – 18 JAM HEX NUT ZP	4
7	2520-357	½ - 13 LOCK HEX NUT GR A ZP	3
8	2520-464	5/8 – 11 WHIZLOCK HEX NUT GR 2 ZP	2
9	2525-251	3/8 MEDIUM LOCK WASHER ZP	2
10	2526-253	3/8 SAE FLAT WASHER ZP	4
11	2526-355	½ FLAT WASHER HARDENED ZP	3
12	2526-454	5/8 SAE FLAT WASHER HARDENED ZP	2
13	2565-179	YETTER DECAL	2
14	2570-448	.120 BOWTIE LOCKING COTTER ZP	1
15	2968-218	INJECTOR HOLDER W.A.	2
16	2968-226	MAIN MOUNT BRACKET W.A.	1
17	2968-383	TRIANGULAR MOUNT SPACER, ZP	4
18	2968-384	LEFT 2968 ARM	1
19	2968-385	RIGHT 2968 ARM	1
20	2968-386	TRIANGULAR MOUNT	2
21	2984-497	AIR CYLINDER ROD PIN	1

PARTS IDENTIFICATION

2968-132 (SHOWN) 10" WHEEL ASSEMBLY

2968-133 11" WHEEL ASSEMBLY

MUST ALIGN GREASE ZERK WITH ALL GREASE GROOVES

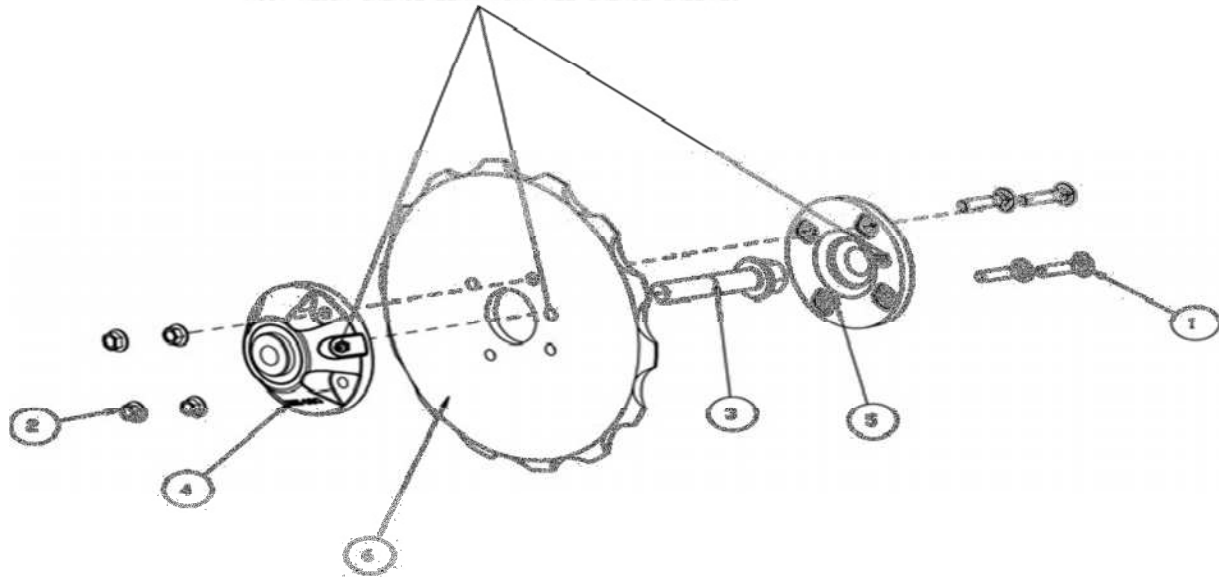

ITEM	PART #	DESCRIPTION	QTY
1	2505-207	5/16 – 18 X 1 ¼ CARRIAGE BOLT GR 5 ZP	4
2	2520-206	5/16 – 18 FLANGE LOCK NUT	4
3	2570-740	D-BOLT, FLANGED, 5/8 – 11 X 2.812 GR 8	1
4	2965-128	HUB & BEARING, 4 BOLT	1
5	2965-352	HUB CAP, 4 BOLT, BLACK	1
6	2968-320	10.05 X .256 FERTILIZER WHEEL (SHOWN)	1
	2968-364	11.05 X .256 FERTILIZER WHEEL	1

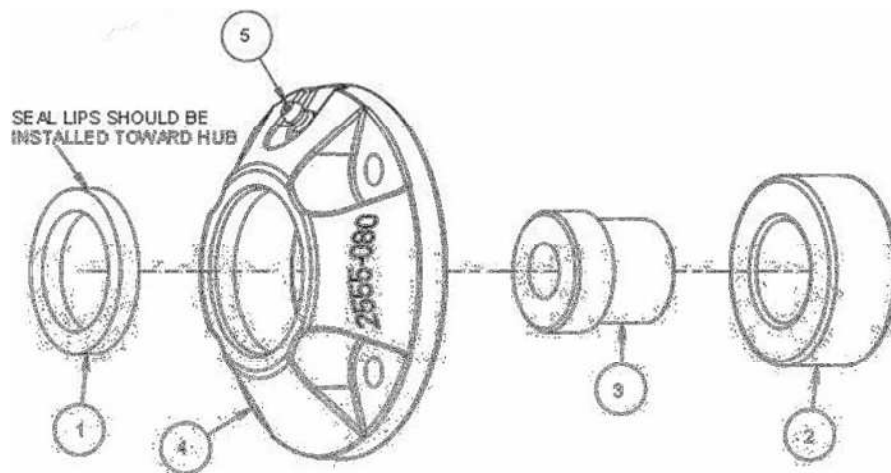

ITEM	PART #	DESCRIPTION	QTY
1	2550-069	TRIPLE LIP SEAL, NTI# 1812-5	1
2	2570-594	BEARING, 2 ROW	1
3	2570-715	BEARING INSERT	1
4	2965-351	HUB CASTING, MACHINED, 4 BOLT	1
5	2533-110	¼ - 28 SELF-TAP ZERK, STRAIGHT	1





**REAR KNIFE OPTION
CALL YETTER FOR DETAILS**



NOTES:



A Tradition of Solutions since 1930

Yetter Farm Equipment Co

PO BOX 358 109 S. McDonough

Colchester, IL 62326-0358

Phone: 309-776-4111

Toll Free: 800-447-5777

Email: info@yetterco.com

For updated models and manuals visit the Yetter website:

www.yetterco.com

© Yetter Farm Equipment Co. All Rights Reserved

2565-960 – 02/2019