



**2967-180B**  
**RESIDUE MANAGER**  
FOR  
**2959 OFFSET INJECTION COULTER**  
**OPERATOR'S / INSTRUCTION MANUAL**  
**W/ PARTS IDENTIFICATION**  
2565-483\_REV\_F 12/2022



**YETTER MANUFACTURING CO.**  
*FOUNDED 1930*

Colchester, IL 62326-0358  
Toll free: 800/447-5777  
309/776-3222 (Fax)

Website: [www.yetterco.com](http://www.yetterco.com)  
E-mail: [info@yetterco.com](mailto:info@yetterco.com)

**YETTER**

## FOREWORD

You've just joined an exclusive but rapidly growing club.

For our part, we want to welcome you to the group and thank you for buying a Yetter product.

We hope your new Yetter implement will help you achieve both increased productivity and increased efficiency so that you may generate more profit. This operator's manual has been designed into six major sections.

Foreword, Safety Precautions, assembly instructions, Operation, parts identification and troubleshooting.

It is important the owner/operator knows the implement model number and serial number. Write the serial and model number in the space provided and use it in all correspondence when referring to the implement.

 Throughout the manual references may be made to left side and right side. These terms are used as viewed from the operator's seat facing the front of the tractor.

 This **SAFETY ALERT SYMBOL** indicates important safety messages in the manual. When you see this symbol, be alert to the possibility of **PERSONAL INJURY** and carefully read the message that follows.

The word **NOTE** is used to convey information that is out of context with the manual text. It contains special information such as specifications, techniques, reference information and other information of a supplementary nature.

The word **IMPORTANT** is used in the text when immediate damage will occur to the machine due to improper technique or operation. Important will apply to the same information as specified by note only of an immediate and urgent nature.

It is the responsibility of the user to read the operator's manual and comply with the safe and correct operating procedure and to lubricate and maintain the product according to the maintenance schedule in the operator's manual.

The user is responsible for inspecting his machine and for having parts repaired or replaced when continued use of the product would cause damage or excessive wear to the other parts.

It is the user's responsibility to deliver his machine to the Yetter dealer who sold him the product for service or replacement of defective parts that are covered by the warranty policy.

If you are unable to understand or follow the instructions provided in the publication, consult you local Yetter dealer or contact:

### YETTER MANUFACTURING CO.

309/776-4111

800/447-5777

309/776-3222 (FAX)

Website: [www.yetterco.com](http://www.yetterco.com)

E-mail: [info@yetterco.com](mailto:info@yetterco.com)

## WARRANTY POLICY

Yetter Manufacturing warrants all products manufactured and sold by it against defects in material. This warranty being expressly limited to replacement at the factory of such parts or products as will appear to be defective after inspection. This warranty does not obligate the Company to bear cost of labor in replacement of parts. It is the policy of the company to make improvements without incurring obligations to add them to any unit already sold. No warranty is made or authorized to be made, other than herein set forth. This warranty is in effect for one year after purchase.

Model Number: \_\_\_\_\_

Dealer : \_\_\_\_\_

**Yetter Manufacturing warrants its own products only and cannot be responsible for damage to equipment on which it is mounted.**

# SAFETY

**A brief description of signal words that may be used in this manual:**

**CAUTION:** Used as a general reminder of good safety practices or to direct attention to unsafe practices.

**WARNING:** Denotes a specific potential hazard.

**DANGER:** Denotes the most serious specific potential hazard.

## SAFETY PRECAUTIONS

You can make your farm a safer place to live and work if you observe the safety precautions given. Study these precautions carefully and insist that those working with you and for you follow them.

Finally, remember this: an accident is usually caused by someone's carelessness, neglect or oversight.



### WARNING

Never clean, lubricate or adjust a machine that is in motion. Always lower or block the implement before performing service.

If the machine must be serviced in the raised position, jack or block it up to prevent it from accidentally falling and injuring someone.

Do not allow riders on the tractor or implement.

Use speeds and caution dictated by the terrain being traversed. Do not operate on any slope steep enough to cause tipping or loss of control.

Be sure all personnel are clear of the immediate area before operating.

Read and understand the operator's manual and require all other persons who will operate the equipment to do the same.

Be familiar with all tractor and implement controls and be prepared to stop engine and implements quickly in an emergency.



### CAUTION

Consult your implement and tractor operator's manual for correct and safe operating practices.

Beware of towed implement width and allow safe clearance.

**FAILURE TO HEED MAY RESULT IN PERSONAL INJURY OR DEATH.**

## TABLE OF CONTENTS

FOREWORD.....	2
SAFETY.....	3
TABLE OF CONTENTS.....	4
ASSEMBLY INSTRUCTIONS.....	5-8
OPERATION.....	9
MAINTENANCE.....	10
TROUBLESHOOTING.....	11
PARTS IDENTIFICATION.....	12-15

# ASSEMBLY INSTRUCTIONS

## GENERAL INFORMATION

Examine all equipment carefully for damage or shortages.

Lubricate all bearings and moving parts as assembled.



Reference to front, rear, left and right in this installation instruction are made when sitting in the operator's seat facing direction of forward travel.

## BOLT TORQUE

### READ THESE INSTRUCTIONS FIRST:

1. Improperly tightened bolts will result in damage, breakage, expense, and down time.
2. Always replace bolts with the specified grade and type.
3. Torque properly before first use of the machine and every 2-4 hours of use until you are sure bolts are staying tight.
4. The chart below is a guide for proper torque. Use it unless a specified torque is called out elsewhere in the manual.
5. Torque is the force you apply to the wrench handle or the cheater bar, times the length of the handle or bar.
6. Use a torque wrench whenever possible.

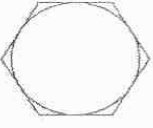
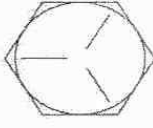
The following table shows torque in ft. lbs.

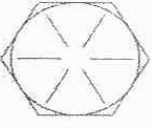
BOLT DIA. AND THREADS PER INCH			OR		
	GRADE 2	GRADE 5		A-325	GRADE 8
1/4	6			10	14
5/16	12			20	30
3/8 - 16	25			35	50
7/16 - 14	35			55	80
1/2 - 13	55			85	125
9/16 - 12	75			125	175
5/8 - 11	105			170	235
3/4 - 10	185			305	425
7/8 - 9	170			445	690
1-8	260			670	1030
1 1/8 - 7	365			900	1460
1 1/4 - 7	515			1275	2060
1 3/8 - 6	675			1675	2700
1 1/2 - 6	900			2150	3500
1 3/4 - 5	1410			3500	5600

## ASSEMBLY INSTRUCTIONS



**WARNING: NEVER WORK UNDER THE EQUIPMENT WHILE IN A RAISED POSITION WITHOUT USING SAFETY LOCK UPS. FAILURE TO DO SO MAY LEAD TO PERSONAL INJURY OR DEATH.**

**STEP 1.** Remove the coulter blade from the 2959 hub-assembly before attaching the residue manager bracket. Remove the 5/8" bolt from the coulter arm assembly that secures the hub and spindle assembly to the arm. Remove the hub and spindle assembly from the coulter arm. Insert the 3/8" x 1 1/2" bolt through the arm.

NOTE: The head of the bolt should be installed on the same side as the hub and blade will be installed.

Replace the hub/spindle onto the arm and secure with the 5/8" bolt, lock washer and 2967-549 pin adjustment plate. Also, install the 3/8" lock hex nut onto the 3/8" x 1 1/2" bolt. DO NOT fully tighten at this time, fine tuning of alignment of adjustment holes will be done later.

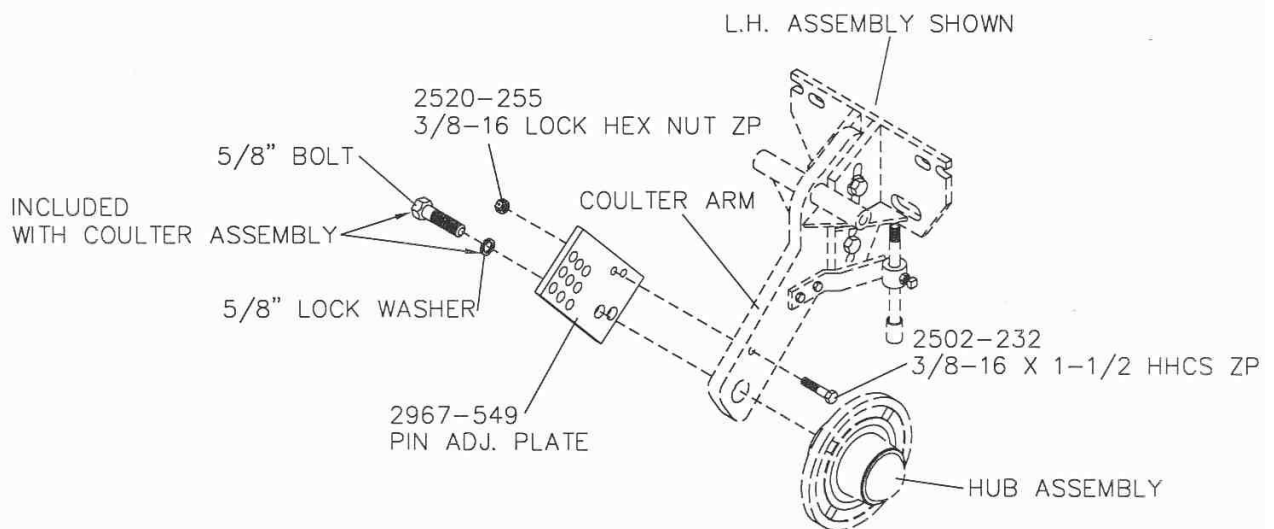

1656-1

## ASSEMBLY INSTRUCTIONS

**STEP 2.** Attach the 2959-206 R.M. arm to the coultter arm using the 5/8" x 9" bolt, 4) 5/8" flat washers, 2) pivot bushings (2967-553) and 5/8" lock hex nut.

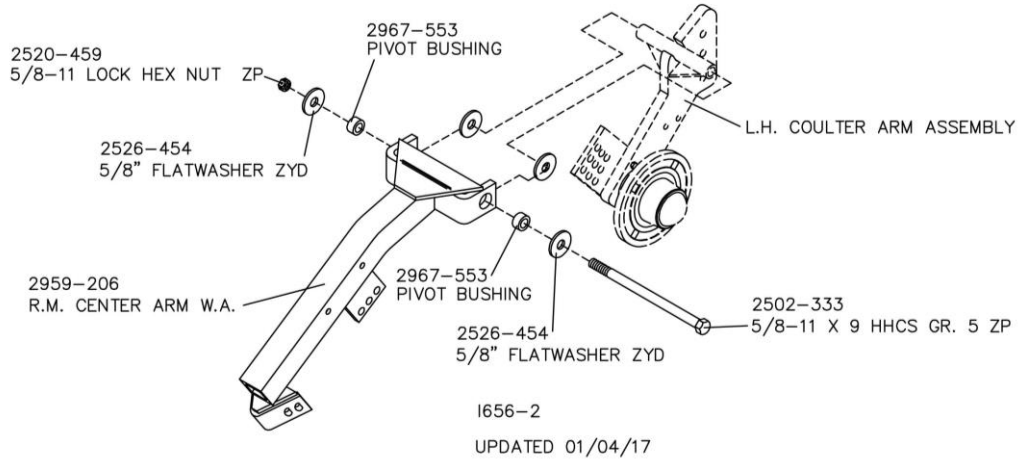

**STEP 3.** Insert the adjustment pin into the arm and the Adjustment Plate. Check the alignment of all the adjustment holes, move adjustment plate as needed then securely tighten the 5/8" spindle bolt and the 3/8" x 1 1/2" bolt. Install the adjustment pin and secure with 1/8" hairpin clip.

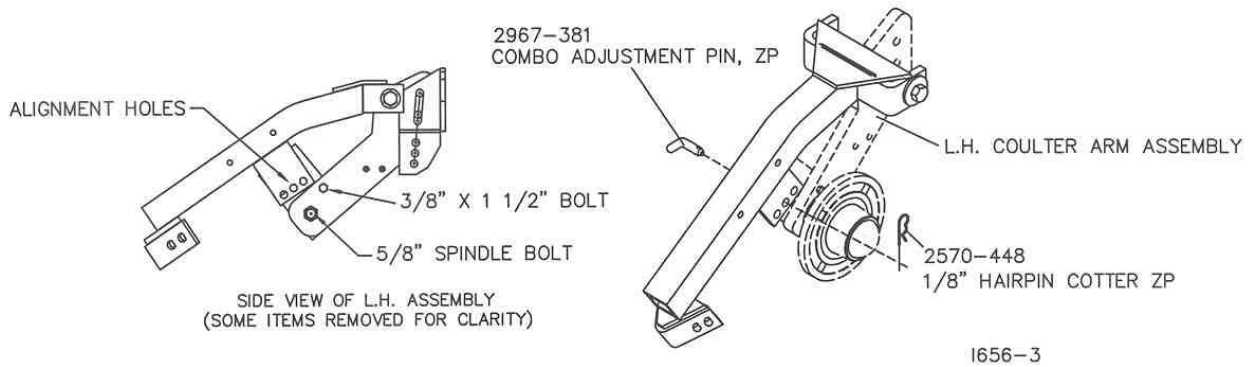

## ASSEMBLY INSTRUCTIONS

**STEP 4.** Attach the 2967-181 Quick Adjust Assembly to the residue manager arm using 2) 3/8" x 3 1/4" bolts, 2) spacer bushings and 3/8" lock hex nuts.

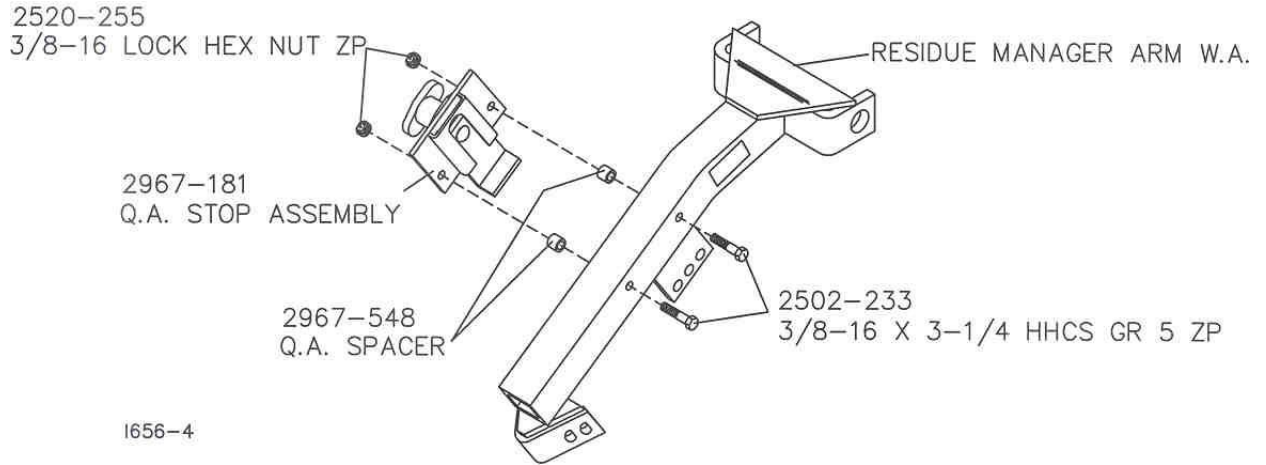

L.H. ASSEMBLY SHOWN

**STEP 5.** Fasten the R.M. wheel assemblies to the 2959-206 R.M. arm using 5/8" lock washers and 5/8" hex nuts. Torque 150 ft.lbs. Adjust the bearing shield to top dead center, rotated forward. Torque 150 ft.lbs.

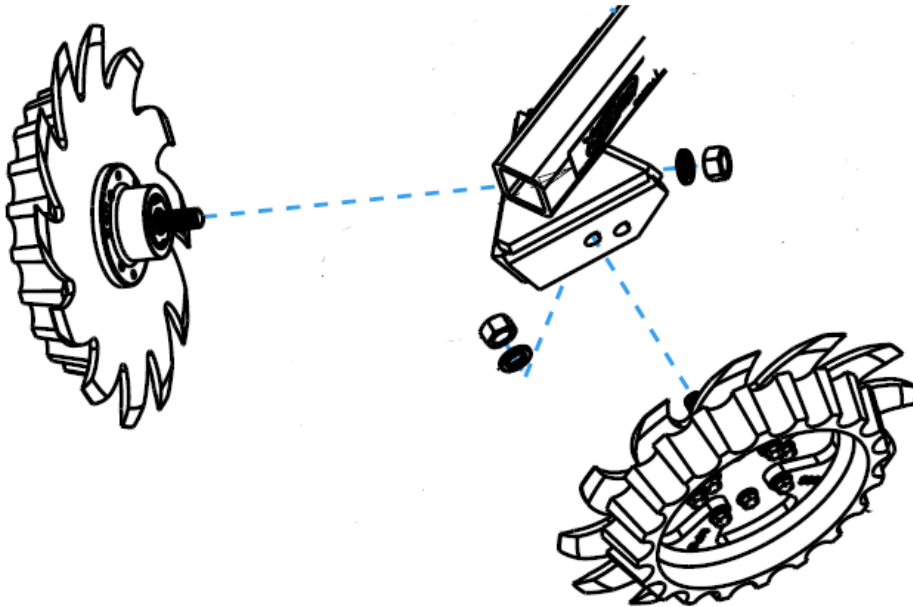



## OPERATION



**CAUTION:** Where rocks are present the residue manager should be set in the “float” position, not locked down.

**STEP 1.** Adjust the residue manager to move crop residue aside and not move any soil. Adjustments to the residue manager may have to be made when changing field conditions and type and amount of residue. By removing the adjustment pin the residue manager wheel can be allowed to “float” and the quick adjust will act as a down stop. If residue managers are set to “float”, check for clearance with drive shafts and frames.

### **ROW CLEANER DO's AND Don'ts**

1. **DO NOT move soil; Residue Managers are designed to move crop residue only.**
2. **DO NOT operate planter at slow speeds, ground speed affects how aggressive the spoke wheels are; operate at sufficient speed (4-6 mph) to maintain good residue flow.**
3. **DO NOT expect 100% of crop residue to be cleared, it is not necessary and would necessitate engaging the soil. The width of path cleared depends on ground conditions, depth setting and ground speed.**
4. **DO expect to see wheels occasionally quit turning, indicates ideal (shallow) setting which is not moving soil.**
5. **DO adjust toolbar frame height 20”-22” and drawbar correctly. Very important to ensure planter opener will follow ground contours properly.**



**IMPORTANT:** For proper operation, the planter frame must operate level (for, aft and side to side) and at the correct height, typically 20”-22”.

## MAINTENANCE

### **Storing the Equipment**

Store the machine in an area away from human activity

Store machine in RAISED position.

Install service locks on all wheel cylinders.

At the end of the season, the machine should be thoroughly inspected and prepared for storage. Repair or replace any worn or damaged components to prevent down time at the start of the next season. Store machine under cover with all parts in operating condition.

- Clean machine thoroughly to remove all dirt, debris and crop residue, which would hold moisture and cause rusting.
- Inspect machine for worn or broken parts. See your Yetter Farm Equipment dealer during the off-season so that parts or service can be acquired when machine is not needed in the field.
- Lubricate bearings as outlined in the Lubrication section
- Paint all parts which are chipped or worn and require repainting.
- Store machine in a clean, dry place with the planting unit out of the sun.
- If the machine cannot be stored inside, cover with a waterproof tarpaulin and tie securely in place.
- Do not allow children to play on or around the machine

• TROUBLESHOOTING

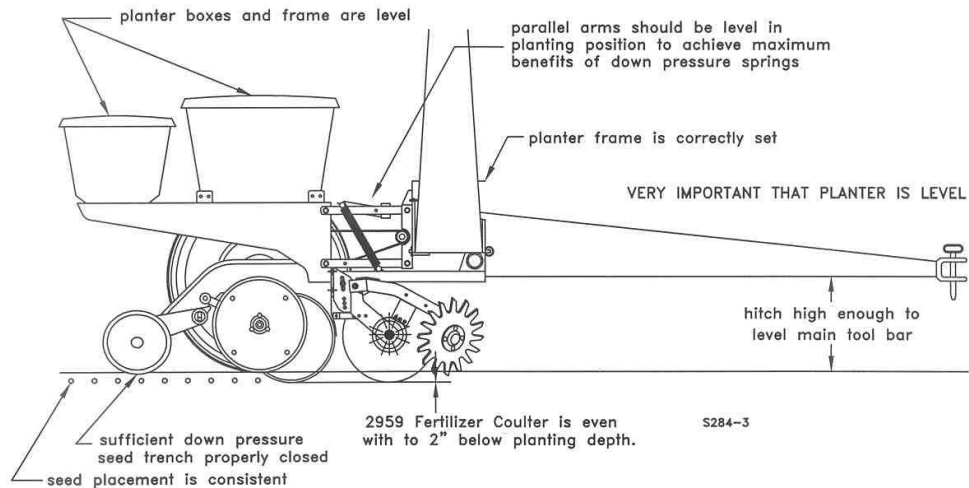

Figure A. (Correct)

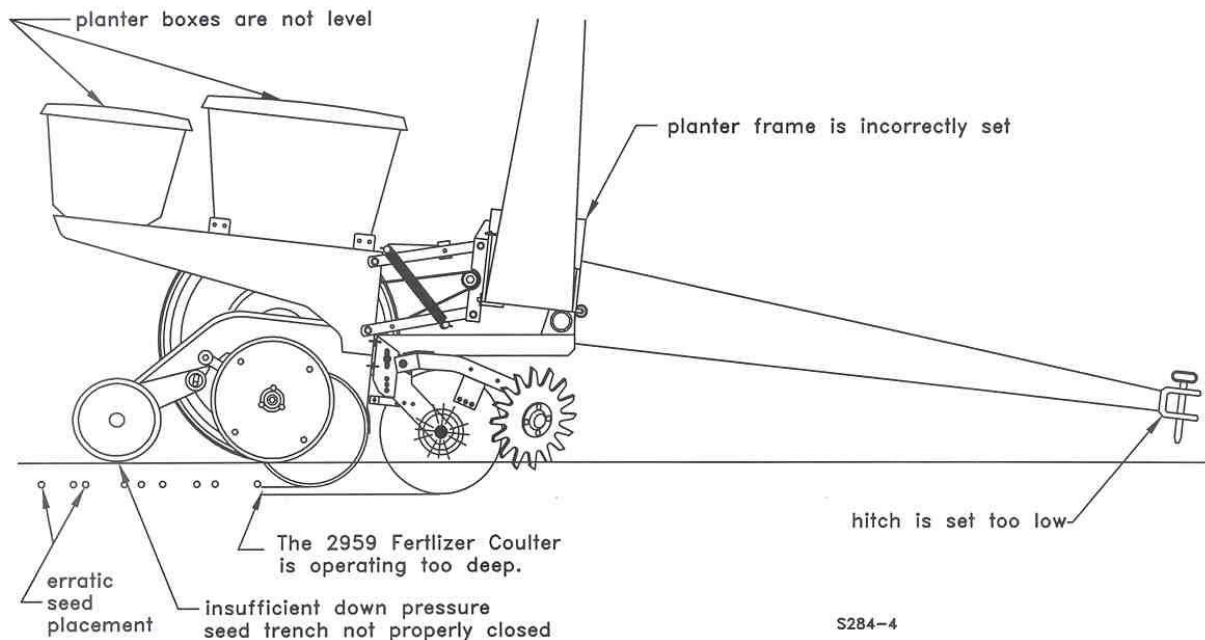

Figure B. (Incorrect)

**Figure A.** – The planter frame is 20" off the ground. To ensure this, visually check to see that the planter boxes are level and that the planter unit parallel arms are also parallel with the ground. **When using planter attachments located in front of the planter unit, this setting is very important.**

**Figure B.** – The planter hitch is set too low while the planter remains at 20" off the ground. Notice from the illustration that the unit mounted coulter is running deeper in the ground.

Note – Both illustrations are strictly for reference only. They are intended to show that proper adjustment of the hitch height is crucial. Consult your planter operator's manual for the proper height adjustment of the hitch.

Note – The drawbar extension kit (6600-128) offered by Yetter Mfg. Co. may be used to alleviate the condition shown in figure B.

## PARTS IDENTIFICATION

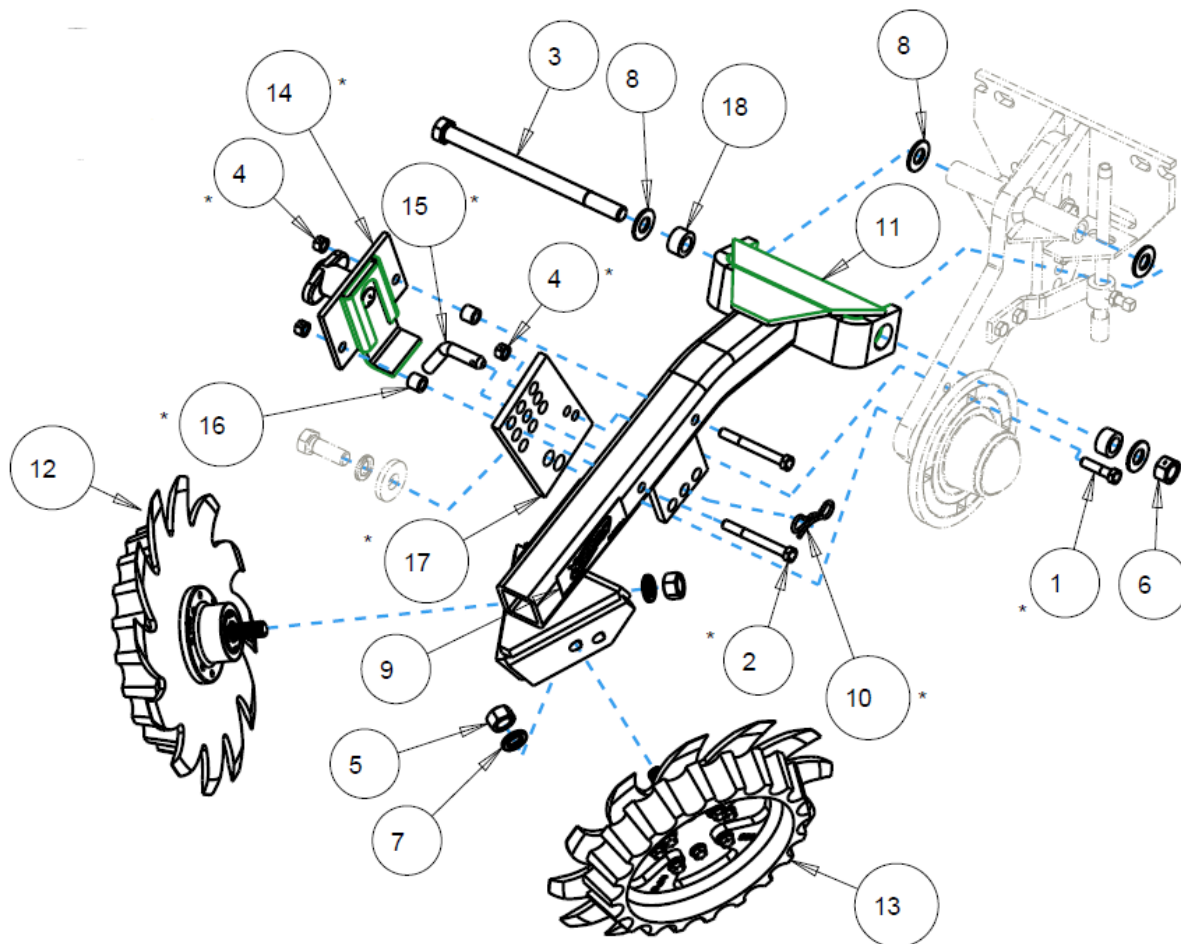

ITEM	PART NO.	DESCRIPTION	QTY
1	2502-232	3/8-16 X 1 1/2 HHCS GR 5 ZYD	1
2	2502-233	3/8-16 X 3 1/4 HHCS GR 5 ZP	2
3	2502-333	5/8-11 X 9 HHCS GR. 5 ZP	1
4	2520-255	3/8-16 LOCK HEX NUT, GR A, ZP	3
5	2520-452	5/8-11 HEX NUT GR 8 ZP	2
6	2520-459	5/8-11 LOCK HEX NUT, GR B, ZP	1
7	2525-451	5/8 MED. LOCKWASHER ZP.	2
8	2526-454	5/8 SAE FLATWASHER HRD'ND ZP	4
9	2565-162	YETTER DECAL	2
10	2570-448	.120 BOWTIE LOCKING COTTER ZP	1
11	2959-206	R.M. CENTER ARM W.A.	1
12	2966-140-ST-FW	SHRKTH ASSY,RH,3"D-BOLT FLT WL	1
13	2966-141-ST-FW	SHRKTH ASSY,LH,3"D-BOLT FLT WL	1
14	2967-181	Q.A. STOP ASSEMBLY	1
15	2967-381	COMBO ADJUSTMENT PIN, ZP	1
16	2967-548	Q.A. SPACER	2
17	2967-549	PIN ADJ. PLATE	1
18	2967-553	PIVOT BUSHING	2

# PARTS IDENTIFICATION

## 2959-107 AIR CYLINDER HARDWARE KIT

ITEM	PART NO.	DESCRIPTION	QTY
1	2502-232	3/8-16 X 1 1/2 HHCS GR 5 ZYD	1
2	2502-243	3/8-16 X 3-1/2 HHCS GR 5	2
3	2502-245	3/8-16 X 1-3/4 HHCS GR 5 ZP	2
4	2502-294	1/2-13 X 1-1/2 HHCS GR5 YD	1
5	2502-295	1/2-13 X 2-3/4 HHCS GR5 ZP	2
6	2502-333	5/8-11 X 9 HHCS GR. 5 ZP	1
7	2502-340	5/8-18 X 1 3/4 HHCS GR5 ZP	1
8	2503-254	3/8-16 X 1 SQ. HCPSS, GR5ZP	1
9	2505-337	1/2-13 X 1 1/4 CARBLT G5ZP	4
10	2515-312	1/4 NPT X 1-1/16 COUPLER	1
11	2520-255	3/8-16 LOCK HEX NUT ZP	4
12	2520-357	1/2-13 LOCK HEX NUT, GR A, ZP	1
13	2531-107	1/8 X 1 COTTER PIN	2
14	2959-206	R.M. CENTER ARM W.A.	1
15	2959-311	COULTER MOUNT	1
16	2959-312	1" OD X .406" ID SPACER	2
17	2959-313	CLEVIS PIN, ZP .438" x 3.5"	1
18	2959-314	ARM PLATE	1
19	2959-315	BUSHING .688"L (#755017)	2
20	2967-622	9/16" SPACER ZP	1
21	2959-317	CLEVIS PIN 1.25"	1

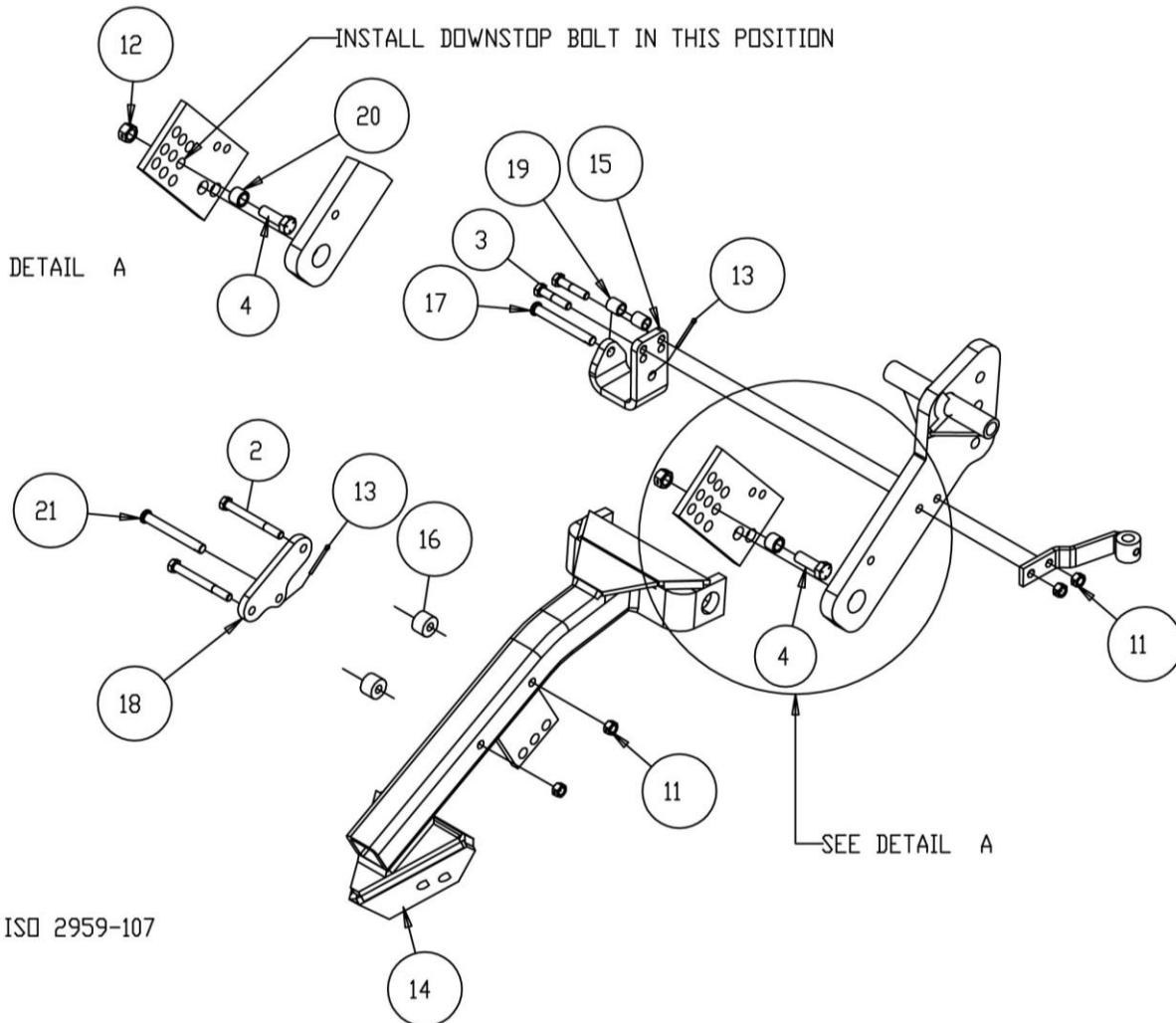

# PARTS IDENTIFICATION

## 2966-140-ST-FW

ITEM	PART NO.	DESCRIPTION	QTY
1	2502-220	5/16-18 X 3/4 HHFS GR5 ZP	4
2	2502-221	5/16-18 X 1 HHFS GR5 ZP	4
3	2515-562	13" WHEEL COVER, BLACK	2
4	2571-286	SHARKTOOTH WHEEL, 8 BOLT	1
5	2965-500	HUB ASSEMBLY, 1.406 SPINDLE	1
6	2967-560	FLOATER WHEEL	1

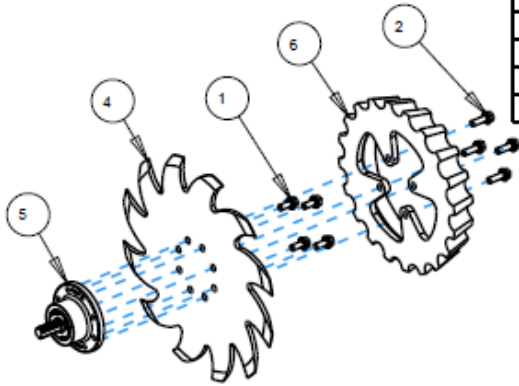

## 2966-140-BW-FW

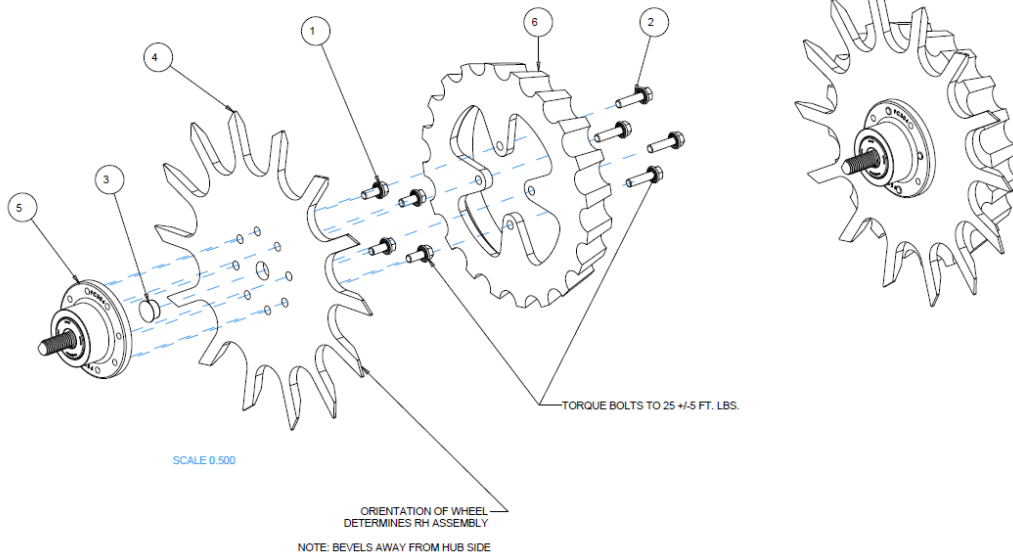

ITEM	PART NO.	DESCRIPTION	QTY
1	2502-220	5/16-18 X 3/4 HHFS GR5 ZP	4
2	2502-222	5/16-18 X 1-1/4 HHFS GR5 ZP	4
3	2570-994	BEVEL WHEEL CENTER HOLE PLUG	1
4	2571-287-R	13" BEVEL WHEEL, 8 BOLT, RH	1
5	2965-500	HUB ASSEMBLY, 1.406 SPINDLE	1
6	2967-560	FLOATER WHEEL	1

# PARTS IDENTIFICATION

## 2966-141-FW

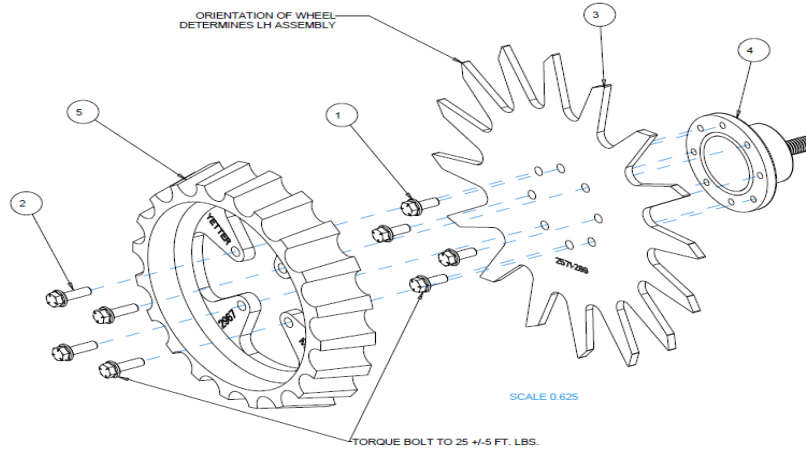

ITEM	PART NO.	DESCRIPTION	QTY
1	2502-220	5/16-18 X 3/4 HHFS GR5 ZP	4
2	2502-221	5/16-18 X 1 HHFS GR5 ZP	4
3	2571-289	13" TAPER TOOTH SPOKE WHEEL, 8 BOLT	1
4	2965-500	HUB ASSEMBLY, 1.406 SPINDLE	1
5	2967-560	FLOATER WHEEL	1

## 2966-140-STF-FW

### RIGHT HAND SHARKTOOTH FINGER WHEEL ASSEMBLY

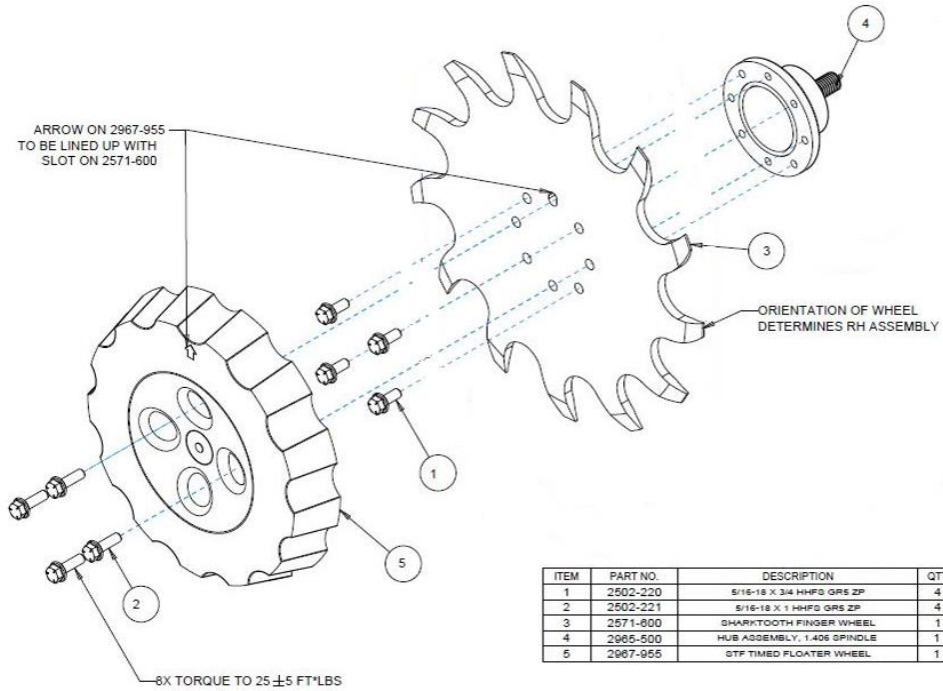

ITEM	PART NO.	DESCRIPTION	QTY
1	2502-220	5/16-18 X 3/4 HHFS GR5 ZP	4
2	2502-221	5/16-18 X 1 HHFS GR5 ZP	4
3	2571-800	SHARKTOOTH FINGER WHEEL	1
4	2965-500	HUB ASSEMBLY, 1.406 SPINDLE	1
5	2967-955	GTF TIMED FLOATER WHEEL	1

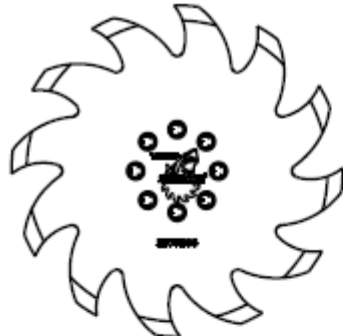

SHARKTOOTH WHEEL ASSEMBLY  
 RIGHT HAND 2966-140-ST(SHOWN)  
 LEFT HAND 2966-141-ST



SHARKTOOTH WHEEL ASSEMBLY W/FLOATER WHEEL  
 RIGHT HAND 2966-140-ST-FW(SHOWN)  
 LEFT HAND 2966-141-ST-FW



BEVEL WHEEL ASSEMBLY  
 RIGHT HAND 2966-140-BW(SHOWN)  
 LEFT HAND 2966-141-BW

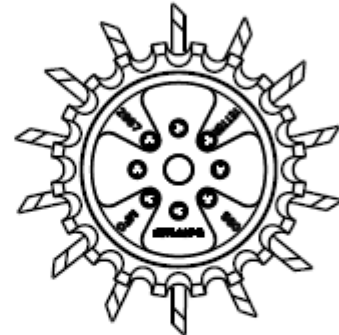

BEVEL WHEEL ASSEMBLY W/FLOATER WHEEL  
 RIGHT HAND 2966-140-BW-FW(SHOWN)  
 LEFT HAND 2966-141-BW-FW

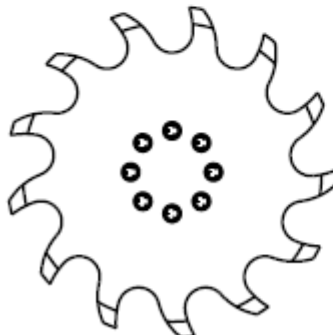

SHARKTOOTH FINGER WHEEL ASSEMBLY  
 RIGHT HAND 2966-140-STF(SHOWN)  
 LEFT HAND 2966-141-STF

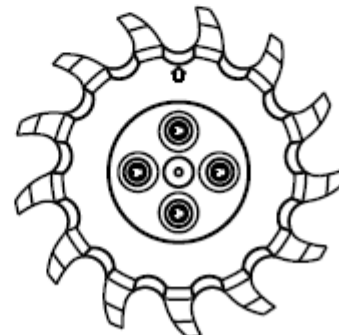

SHARKTOOTH FINGER WHEEL ASSEMBLY W/FLOATER WHEEL  
 RIGHT HAND 2966-140-STF-FW(SHOWN)  
 LEFT HAND 2966-141-STF-FW





A Tradition of Solutions since 1930

Yetter Farm Equipment Co

PO BOX 358 109 S. McDonough

Colchester, IL 62326-0358

Phone: 309-776-4111

Toll Free: 800-447-5777

Email: [info@yetterco.com](mailto:info@yetterco.com)

For updated models and manuals visit the Yetter website:

[www.yetterco.com](http://www.yetterco.com)

© Yetter Farm Equipment Co. All Rights Reserved