

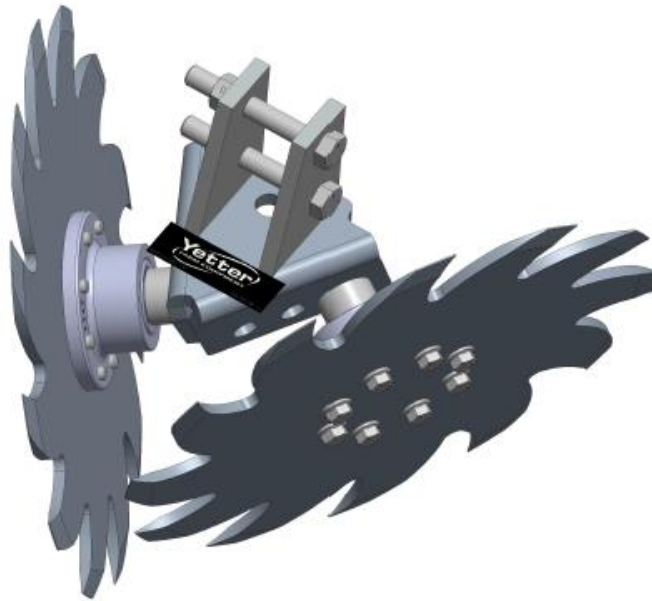

2967-081A
RESIDUE MANAGER FOR JD SCREW ADJUST
2565-448_REV_F • 02/2023



YETTER MANUFACTURING CO.
FOUNDED 1930

Colchester, IL 62326-0358
Toll free: 800/447-5777
309/776-3222 (Fax)
Website: www.yetterco.com
Email: info@yetterco.com

YETTER

INSTALLATION

1. Be sure to install the 3/4" spacers when assembling the spoke wheel and bearing assembly. Using the 5/8" nut, secure the wheel to the bracket. Torque 180 ft.lbs. Stagger spoke wheels so that half of the rows have the left wheel leading and half of the rows have the right wheel leading.
2. Attach the RESIDUE WHEEL assembly to the screw adjust bracket using the two 1/2" x 3 1/2" bolts and lock nuts.

MAINTENANCE

After a few hours use, check all bolts to make sure they are tight.

PARTS IDENTIFICATION 2967-081A-ST

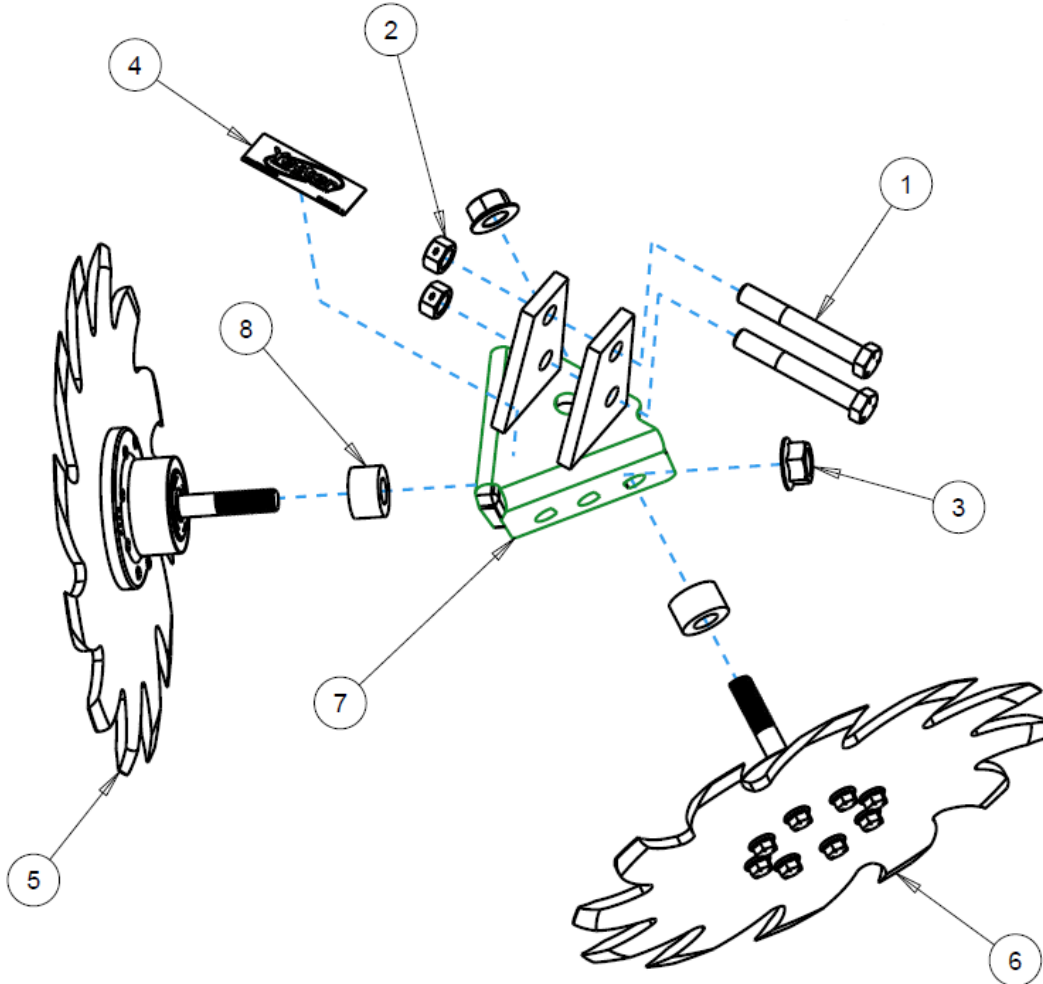

ITEM	PART NO.	DESCRIPTION	QTY
1	2502-316	1/2-13 X 3-1/2 HHCS GRADE 5	2
2	2520-357	1/2-13 LOCK NUT GRADE A	2
3	2520-465	5/8-11 FLANGE NUT GRADE 8	2
4	2965-179	YETTER DECAL	1
5	2966-102-ST	RIGHT HAND SHARK TOOTH WHEEL ASSEMBLY	1
6	2966-103-ST	LEFT HAND SHARK TOOTH WHEEL ASSEMBLY	1
7	2967-257	JD SCREW ADJUST MOUNT BRACKET	1
8	2967-302	SPACER 3/4"	2

PARTS IDENTIFICATION
2966-102 RIGHT HAND SPOKE WHEEL (SHOWN)
2966-103 LEFT HAND SPOKE WHEEL

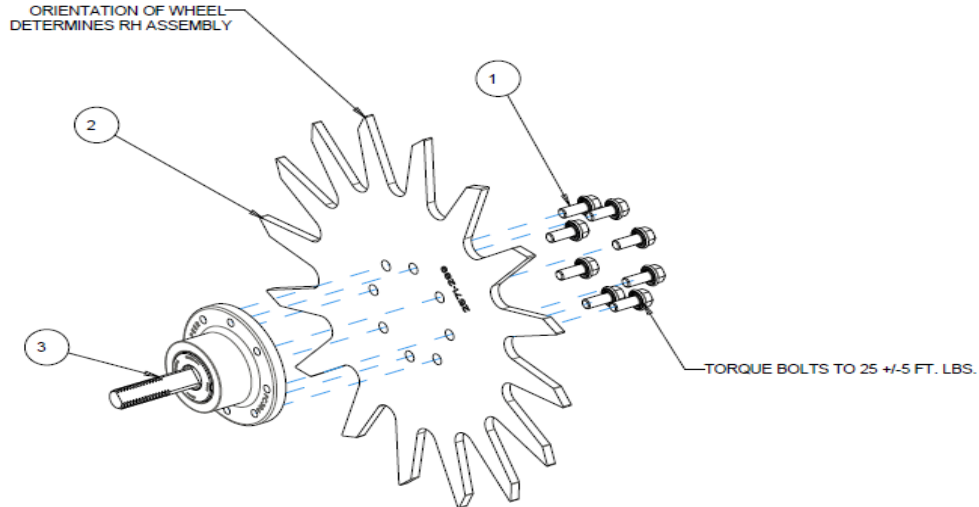

ITEM	PART NO.	DESCRIPTION	QTY
1	2502-220	5/16-18 X 3/4 HHFS GR5 ZP	8
2	2571-289	13" TAPER TOOTH SPOKE WHEEL, 8 BOLT	1
3	2965-501	HUB ASSEMBLY, 2.406 SPINDLE	1

2966-102-BW RIGHT HAND BEVELED WHEEL (SHOWN)
2966-103-BW LEFT HAND BEVELED WHEEL

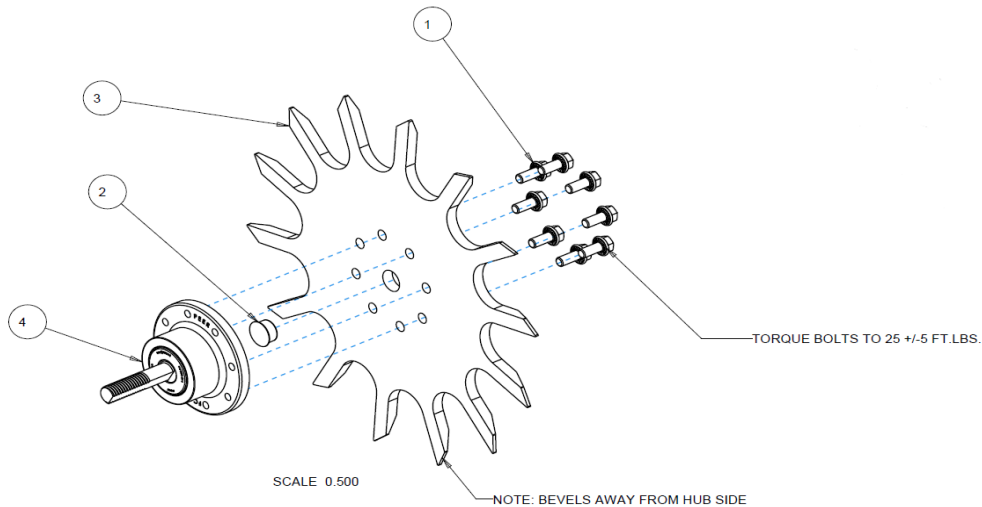

ITEM	PART NO.	DESCRIPTION	QTY
1	2502-220	5/16-18 X 3/4 HHFS GR5 ZP	8
2	2570-994	BEVEL WHEEL CENTER HOLE PLUG	1
3	2571-287-R	13" BEVEL WHEEL, 8 BOLT, RH	1
4	2965-501	HUB ASSEMBLY, 2.406 SPINDLE	1

PARTS IDENTIFICATION
2966-102-ST RIGHT HAND SHARK WHEEL (SHOWN)
2966-103-ST LEFT HAND SHARK WHEEL

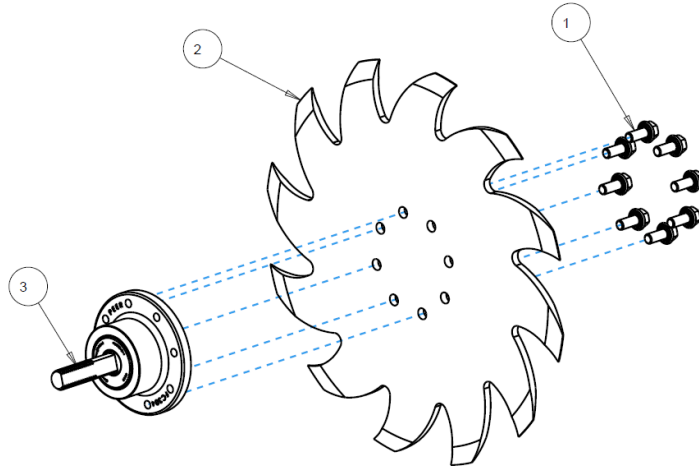

ITEM	PART NO.	DESCRIPTION	QTY
1	2502-220	5/16-18 X 3/4 HHFS GR5 ZP	8
2	2571-286	SHARKTOOTH WHEEL, 8 BOLT	1
3	2965-501	HUB ASSEMBLY, 2.406 SPINDLE	1

2966-102-STF
RIGHT HAND SHARKTOOTH FINGER WHEEL ASSEMBLY

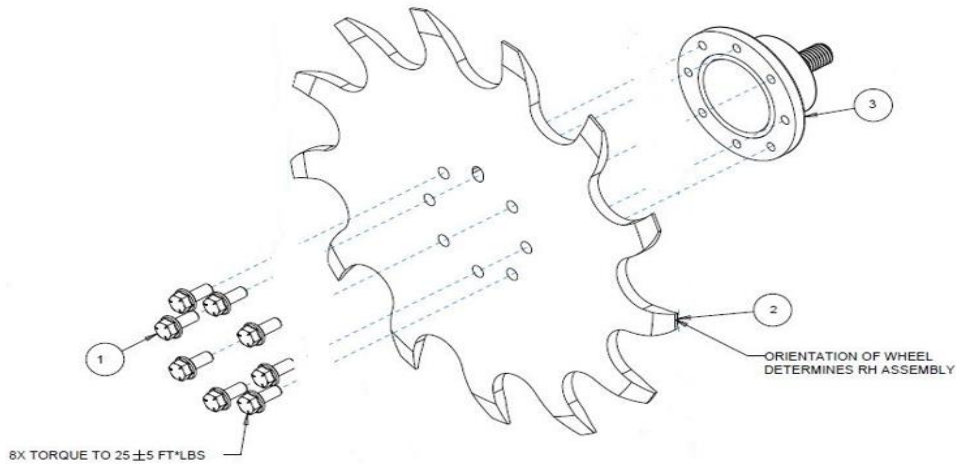

ITEM	QTY	PART NO.	DESCRIPTION
1	8	2502-220	5/16-18 X 3/4 HHFS BOLT GR5
2	1	2571-600	SHARKTOOTH FINGER WHEEL
3	1	2965-501	HUB ASSEMBLY 2.406" SPINDLE

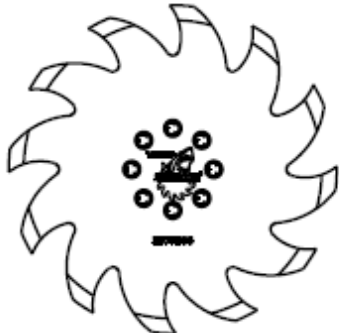

SHARKTOOTH WHEEL ASSEMBLY
 RIGHT HAND 2966-140-ST(SHOWN)
 LEFT HAND 2966-141-ST



SHARKTOOTH WHEEL ASSEMBLY W/FLOATER WHEEL
 RIGHT HAND 2966-140-ST-FW(SHOWN)
 LEFT HAND 2966-141-ST-FW

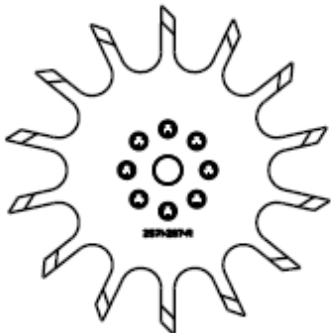

BEVEL WHEEL ASSEMBLY
 RIGHT HAND 2966-140-BW(SHOWN)
 LEFT HAND 2966-141-BW



BEVEL WHEEL ASSEMBLY W/FLOATER WHEEL
 RIGHT HAND 2966-140-BW-FW(SHOWN)
 LEFT HAND 2966-141-BW-FW

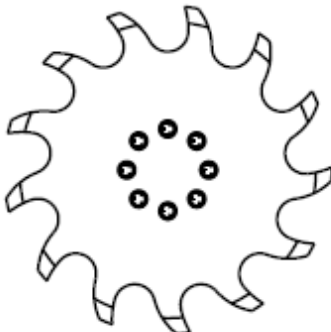

SHARKTOOTH FINGER WHEEL ASSEMBLY
 RIGHT HAND 2966-140-STF(SHOWN)
 LEFT HAND 2966-141-STF

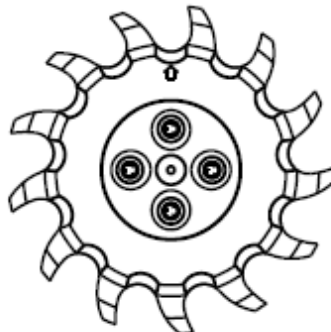

SHARKTOOTH FINGER WHEEL ASSEMBLY W/FLOATER WHEEL
 RIGHT HAND 2966-140-STF-FW(SHOWN)
 LEFT HAND 2966-141-STF-FW

ISO2966-140_ASSEMBLIES

FIELD SERVICE KITS

- 2965-119 - SERVICE KIT FOR 2570-740-2.812 D-BOLT
- 2965-120 - SERVICE KIT FOR 2570-742-3.812 D-BOLT
- 2965-121 - SERVICE KIT FOR 2570-766-2.562 D-BOLT

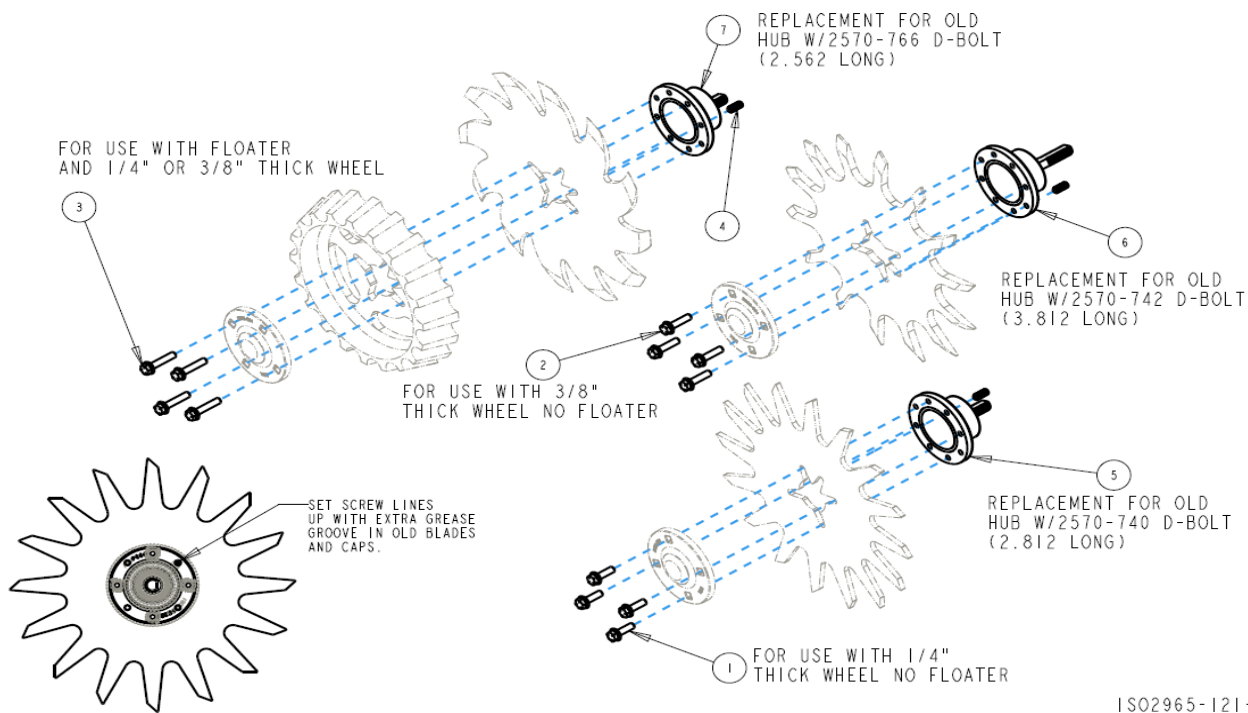

ISO2965-121-2

ITEM	PART NO	DESCRIPTION	QTY
1	2502-221	5/16-18 X 1 HHFS GRADE 5	4
2	2502-222	5/16-18 X 1-1/4 HHFS GRADE 5	4
3	2502-225	5/16-18 X 1-1/2 HHFS GRADE 5	4
4	2940-560	SET SCREW	1
5	2965-500	HUB ASSEMBLY 1.406 SPINDLE	1
6	2965-501	HUB ASSEMBLY 2.406 SPINDLE	1
7	2965-502	HUB ASSEMBLY 1.157 SPINDLE	1



ITEM	PART NO	DESCRIPTION	QTY
1	2505-207	5/16-18 X 1-1/4 CARRIAGE HEAD BOLT GRADE 5	4
2	2520-206	5/16-18 FLANGE LOCK NUT	4
3	2570-742	D-BOLT FLANGE HEAD 5/8-11 X 3.812 GRADE 8	1
4	2965-128	HUB/BEARING ASSEMBLY	1
	2550-069	SEAL	1
	2570-594	BEARING	1
	2570-715	INSERT	1
	2965-351	HUB	1
	2533-110	GREASE FITTING	1
5	2965-352	HUB CAP	1
6	2967-602	SHARK TOOTH WHEEL	1
7	2520-465	5/8-11 FLANGE LOCK NUT GRADE 8	1



A Tradition of Solutions since 1930

Yetter Farm Equipment Co

PO BOX 358 109 S. McDonough

Colchester, IL 62326-0358

Phone: 309-776-4111

Toll Free: 800-447-5777

Email: info@yetterco.com

For updated models and manuals visit the Yetter website:

www.yetterco.com

© Yetter Farm Equipment Co. All Rights Reserved

2565-448_REV_F -02/2023