



**2967-035A
RESIDUE MANAGER
FOR NO-TILL COULTERS**

2565-487_REV_M 06/2026



YETTER MANUFACTURING CO.
FOUNDED 1930

Colchester, IL 62326-0358
Toll free: 800/447-5777
309/776-3222 (Fax)

Website: www.yetterco.com
E-mail: info@yetterco.com

YETTER

FOREWORD

You've just joined an exclusive but rapidly growing club.
For our part, we want to welcome you to the group and thank you for buying a Yetter product.

We hope your new Yetter products will help you achieve both goals-increase your productivity and increase your efficiency so that you may generate more profit.

This operator's manual has been designed into four major sections: Foreword, Safety Precautions, Installation Instructions and Parts Breakdown.

This **SAFETY ALERT SYMBOL** indicates important safety messages in the manual. When you see this symbol, be alert to the possibility of **PERSONAL INJURY** and carefully read the message that follows.

 **DANGER:** Indicates an imminently hazardous situation which, if not avoided "will" result in death or serious injury. This signal word is to be limited to the most extreme situations

 **WARNING:** Indicates a potentially hazardous situation which, if not avoided, "could" result in death or serious injury.

 **CAUTION:** Indicates a potentially hazardous situation, which if not avoided, "may" result in minor or moderate injury. It may also be used to alert against unsafe practices.

 **NOTICE:** Indicates information considered important, but not hazard related (e.g., messages relating to property damage).

It is the responsibility of the user to read the operator's manual and comply with the safe and correct operating procedure and to lubricate and maintain the product according to the maintenance schedule in the operator's manual.

The user is responsible for inspecting his machine and for having parts repaired or replaced when continued use of the product would cause damage or excessive wear to the other parts.

It is the user's responsibility to deliver his machine to the Yetter dealer who sold him the product for service or replacement of defective parts, which are covered by the warranty policy.

If you are unable to understand or follow the instructions provided in this publication, consult your local Yetter dealer or contact:

YETTER MANUFACTURING CO.
309/776-4111
800/447-5777
309/776-3222 (FAX)
Website: www.yetterco.com
E-mail: info@yetterco.com

WARRANTY POLICY

Yetter Manufacturing warrants all products manufactured and sold by it against defects in material. This warranty being expressly limited to replacement at the factory of such parts or products as will appear to be defective after inspection. This warranty does not obligate the Company to bear cost of labor in replacement of parts. It is the policy of the company to make improvements without incurring obligations to add them to any unit already sold. No warranty is made or authorized to be made, other than herein set forth. This warranty is in effect for one year after purchase.

Dealer : _____

Yetter Manufacturing warrants its own products only and cannot be responsible for damage to equipment on which it is mounted.



SAFETY PRECAUTIONS



A brief description of signal words that may be used in this manual:

DANGER: Indicates an imminently hazardous situation which, if not avoided “will” result in death or serious injury. This signal word is to be limited to the most extreme situations.

WARNING: Indicates a potentially hazardous situation which, if not avoided, “could” result in death or serious injury.

CAUTION: Indicates a potentially hazardous situation, which if not avoided, “may” result in minor or moderate injury. It may also be used to alert against unsafe practices.

NOTICE: Indicates information considered important, but not hazard related (e.g., messages relating to property damage).

Consult your implement and tractor operator’s manual for correct and safe operating practices. Be aware of towed implement width and allow safe clearance.

Safety decals are placed on the implement to alert the operator and others to the risk of personal injury or unsafe operation during normal operations and servicing.

1. The safety decals must be kept clean and in good condition to ensure that they are legible.
2. Safety decals must be replaced if they are missing or illegible.
3. When components are replaced during repair or servicing, check that the new components include the necessary safety signs.
4. Replacement safety decals may be obtained from your local dealer.



WARNING

Read these instructions carefully to acquaint yourself with the Equipment. Working with unfamiliar equipment can lead to accidents.

Never park the equipment on a steep incline or leave the equipment running unattended.

Never clean, lubricate or adjust a machine that is in motion.

Always check that straps are secure.

Make sure latches are in pinned position when moving equipment.

Do not allow children to operate this equipment.

Do not allow riders on the equipment, trailer and/or pick-up.

Use speed and caution dictated by the terrain being traversed. Do not operate on any slope steep enough to cause tipping or loss of control.

Read and understand the operator’s manual and require all other persons who will operate the equipment to do the same.

If operating on public roadways, where legal, be certain all lighting is operating properly and observe all traffic laws.

Beware of increased stopping distances and control effort when operating with implements attached.

Be familiar with all controls and be prepared to stop equipment quickly in an emergency.

FAILURE TO HEED MAY RESULT IN PERSONAL INJURY OR DEATH.

TABLE OF CONTENTS

Introduction.....	pg. 2
Warranty.....	pg. 2
Safety Information.....	pg. 3
Table of Contents.....	pg. 4
Optional Equipment.....	pg. 4
Application/Use Guide.....	pg. 5
Assembly Instruction.....	pg.6-9
Operation.....	pg. 10
Maintenance.....	pg. 11
Parts Identification.....	pg.12-14

TITAN F.P.M. RESIDUE MANAGER OPERATION / USE GUIDE



NOTICE: The 2967-035 Residue Manager **Will Limit** the full “up-travel” of the planter row unit. Please check the amount of travel that the planter row unit has **before** going to the field to plant.



NOTICE: The recommended height of a level planter toolbar frame is 18”-22”. Always visually check seed spacing and depth-calibrate your equipment if necessary.

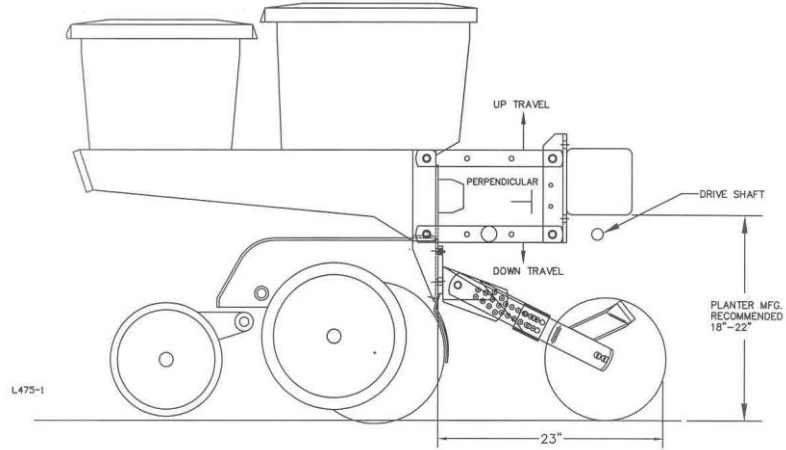

Solution to “UP” travel issue. Trim upper corners of face plate bracket.

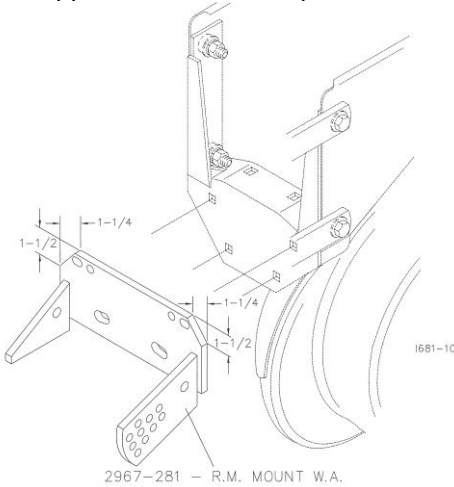

OVERHEAD VIEW

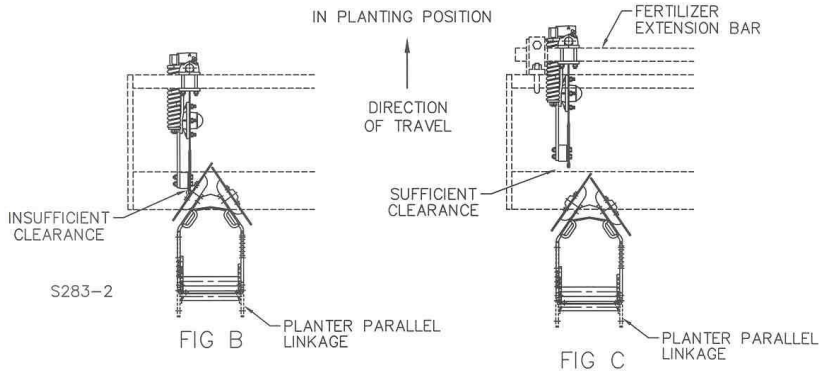

If there is insufficient clearance between the residue manager wheels and the fertilizer coupler opener, then a fertilizer extension bar is required to move the fertilizer coupler forward to have sufficient clearance.

ASSEMBLY INSTRUCTIONS

2967-035 RESIDUE MANAGER ONLY



NOTICE: Do not fully tighten the mounting hardware at this time. Alignment adjustments will be made once the R.M. wheels are attached.

When using the 2967-035 Residue Manager unit with out a coultter, attach the 2967-281 – Mount W.A. using 4) 1/2" x 1 1/2" bolts, large flat washers and lock nuts.

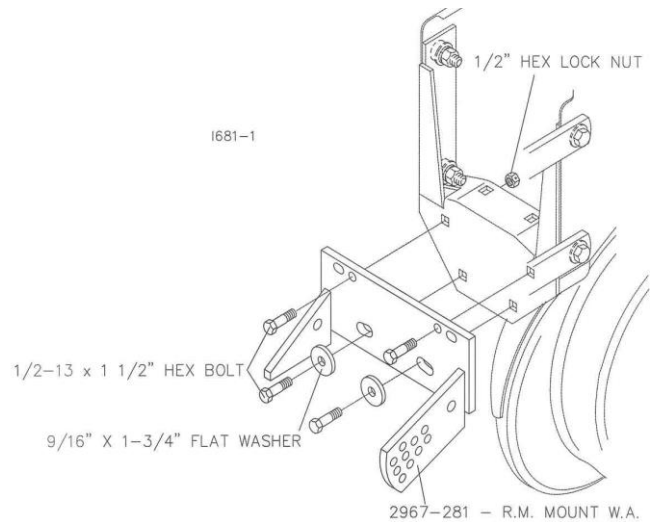

JD MAX EMERGE II COULTER

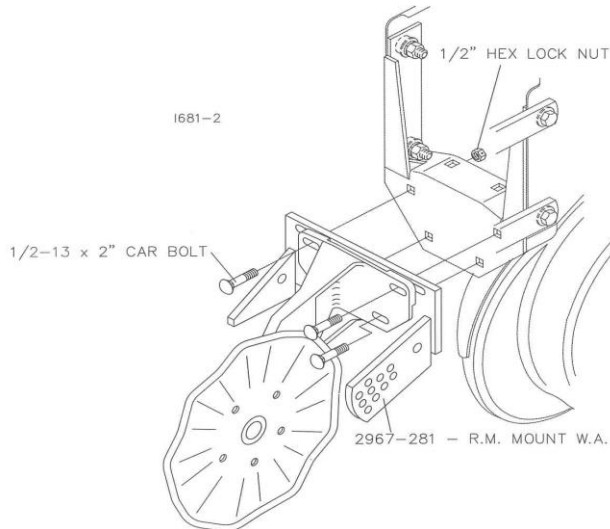

Use 3) 1/2" x 2" carriage bolts when mounting a JD MEII coultter or a White single arm coultter (700728036).

Use 4) 1/2" x 2" carriage bolts when mounting a JD 7000 coultter, Kinze double arm, White double arm, or the Yetter 2960-130 Double Arm Coultter.

2960 SERIES II UNIT MOUNTED CONSERVATION COULTER

Use 2) 1/2" x 2" carriage bolts (upper holes), 1) 1/2" x 2" hex bolt and a large flat washer (lower left hole) are used when mounting the Yetter Series II coultter.

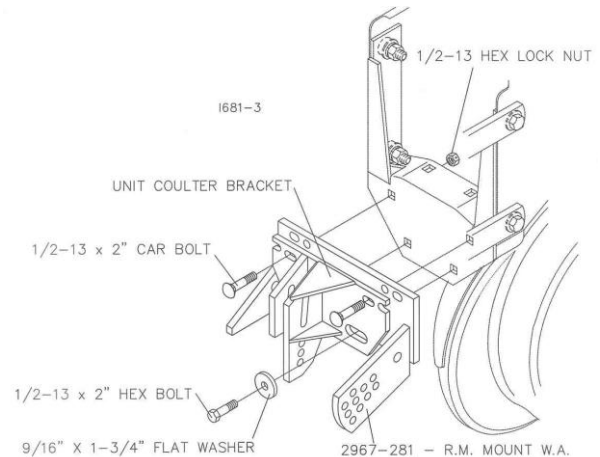

ASSEMBLY INSTRUCTIONS

STEP 1 Install the 2967-283 Adjustment Slide onto the right hand side of the 2967-282 Combo Arm. The adjustment slide should move freely on the combo arm.

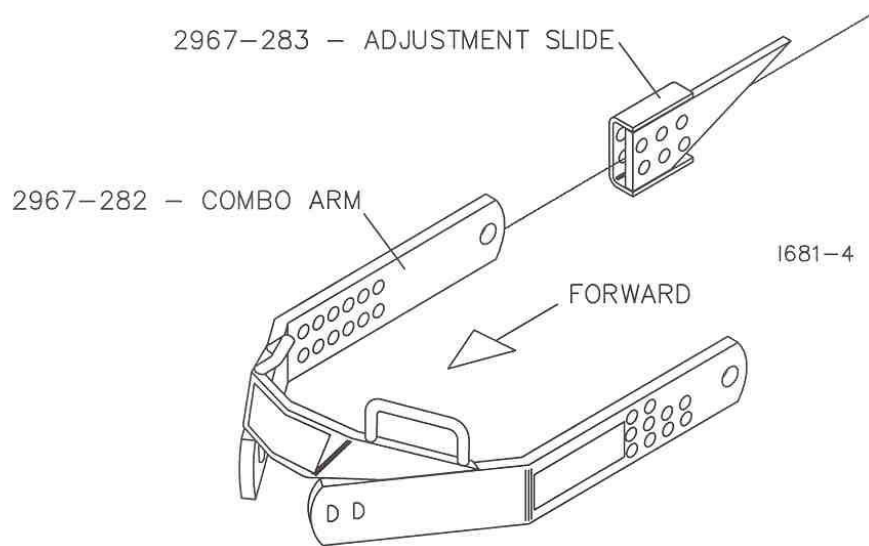

STEP 2 Attach the combo arm assembly to the 2967-281 Mount Bracket using 2) 5/8" x 2" bolts, flat washers, bushings, and lock nuts. Securely tighten the pivot hardware at this time.

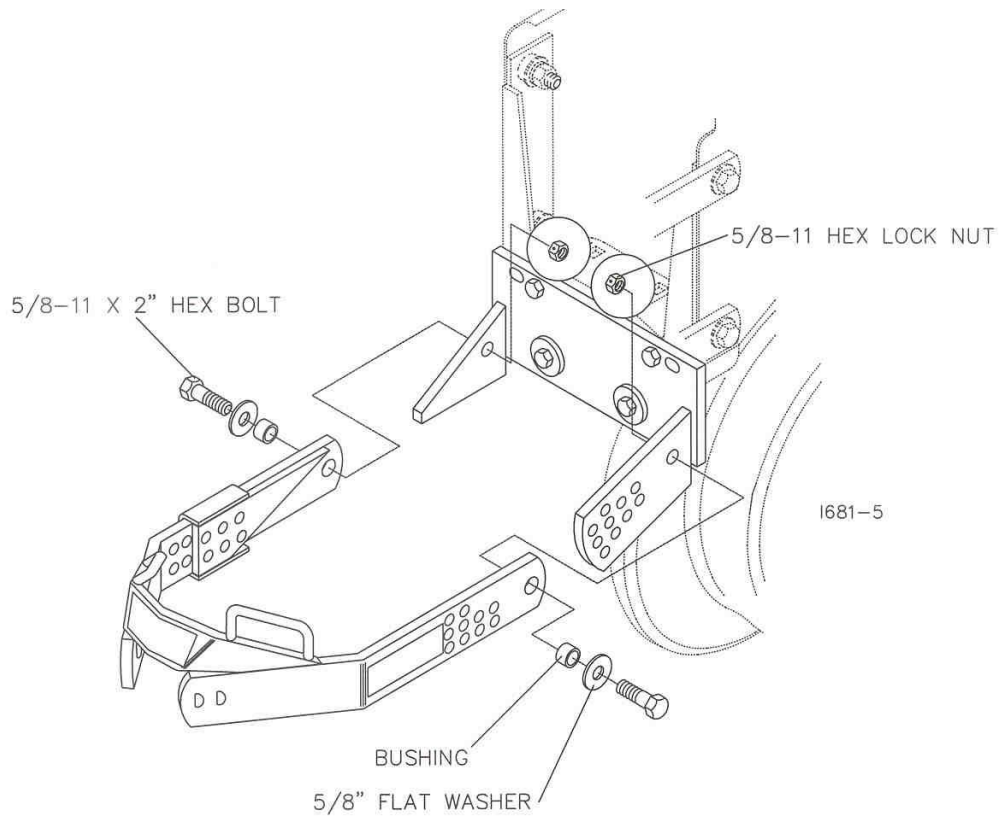

ASSEMBLY INSTRUCTIONS

STEP 3. Install the 2984-326 Adjustment Pin through the adjustment holes of the slide (float) or through the adjustment arm of the mount bracket (rigid) and secure with the 2570-448 Hairpin clip.

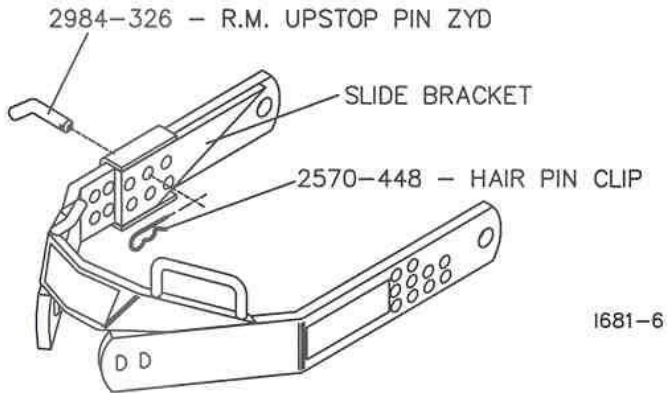

"FLOAT" ADJUSTMENT

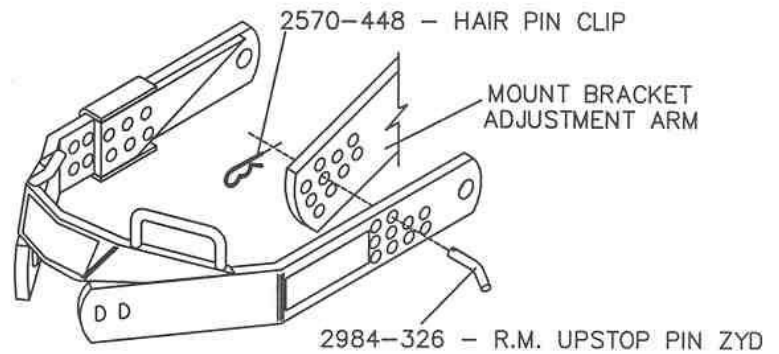

"RIGID" ADJUSTMENT

ASSEMBLY INSTRUCTIONS

STEP 4 Choose the mounting hole in which to attach the R.M. wheels. Both wheels mounted in the front holes – wheels are interlocked. One wheel mounted in the front hole and one mounted in the rear hole – wheels are offset. Both wheels mounted in the rear holes – wheels are spaced apart.

Attach the R.M. wheel/hub assemblies to the 2967-282 Combo Arm using 5/8" lock washers and hex nuts. Adjust the bearing shield to top dead center, rotate slightly forward. **Torque to 190 ft./lbs.**

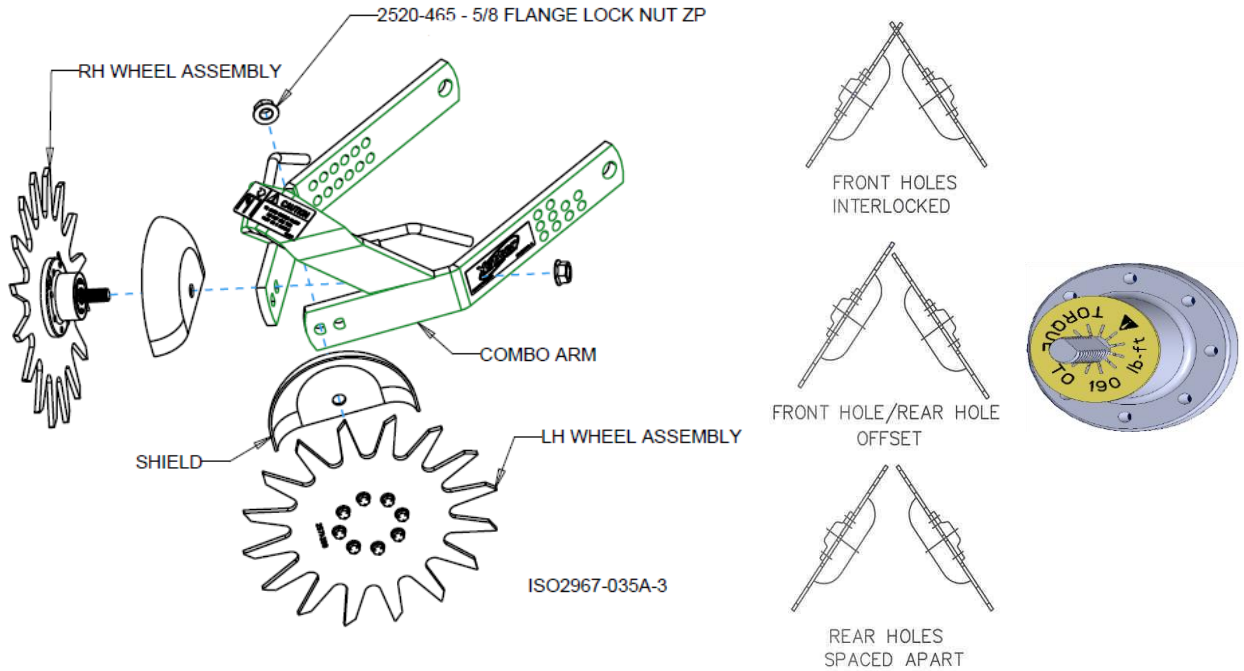

STEP 5 Align the residue manager wheels, conservation coulters (if used) to the planter opener blades. The 2967-281 Mount Bracket has slotted holes in the faceplate to move the residue manager wheels side to side; to be able to center the wheels on the seed furrow. Fully tighten mounting bolts. Torque to 85 ft/lbs.

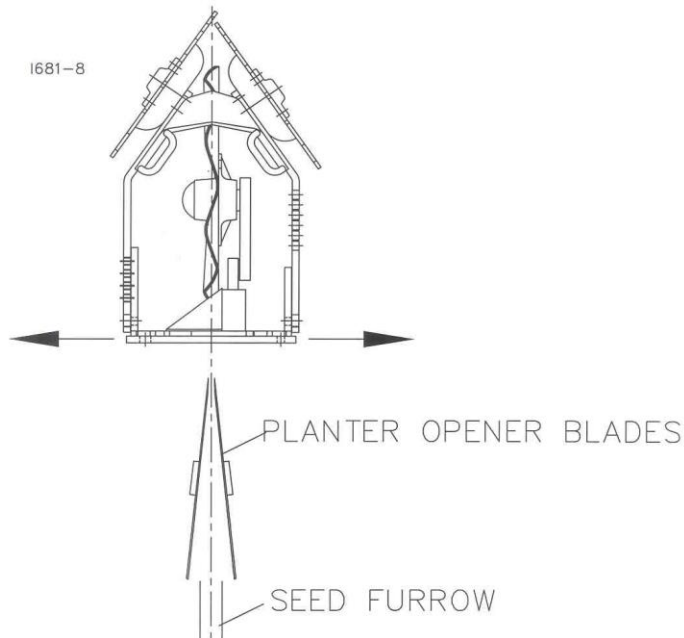

OPERATION



CAUTION: Where rocks are present the residue manager should be set in the “float” position, not locked down.

STEP 1. Adjust the residue manager to move crop residue aside and not move any soil. Adjustments to the residue manager may have to be made when changing field conditions and type and amount of residue. Use the handle for leverage when changing depth settings.

“FLOAT SETTINGS”

To raise the wheels, lift the 2967-282 and move the slide toward the rear.

To lower the wheels move the slide toward the front.

“RIGID SETTING”

To raise the wheels, lift the 2967-282 Combo Arm to the desired position and insert the pin.

To lower the wheels, lower the combo arm to the desired position and insert the pin.

ROW CLEANER DO'S AND DON'TS

1. **DO NOT move soil; Residue Managers are designed to move crop residue only.**
2. **DO NOT operate planter at slow speeds, ground speed affects how aggressive the spoke wheels are; operate at sufficient speed (4-6 mph) to maintain good residue flow.**
3. **DO NOT expect 100% of crop residue to be cleared, it is not necessary and would necessitate engaging the soil. The width of path cleared depends on ground conditions, depth setting and ground speed.**
4. **DO expect to see wheels occasionally quit turning, indicates ideal (shallow) setting which is not moving soil.**
5. **DO adjust toolbar frame height 20”-22” and drawbar correctly. Very important to ensure planter opener will follow ground contours properly.**



NOTICE: For proper operation, the planter frame must operate level (for, aft and side to side) and at the correct height, typically 20”-22”.

MAINTENANCE

Regularly inspect the residue manager for loose or worn bolts. Repair and replace as needed.

Storing the Equipment

Store the machine in an area away from human activity

Store machine in RAISED position.

Install service locks on all wheel cylinders.

At the end of the season, the machine should be thoroughly inspected and prepared for storage. Repair or replace any worn or damaged components to prevent down time at the start of the next season. Store machine under cover with all parts in operating condition.

- Clean machine thoroughly to remove all dirt, debris and crop residue, which would hold moisture and cause rusting.
- Inspect machine for worn or broken parts. See your Yetter Farm Equipment dealer during the off-season so that parts or service can be acquired when machine is not needed in the field.
- Lubricate bearings as outlined in the Lubrication section
- Paint all parts which are chipped or worn and require repainting.
- Store machine in a clean, dry place with the planting unit out of the sun.
- If the machine cannot be stored inside, cover with a waterproof tarpaulin and tie securely in place.
- Do not allow children to play on or around the machine

PARTS IDENTIFICATION

8 BOLT HUB ASSEMBLY

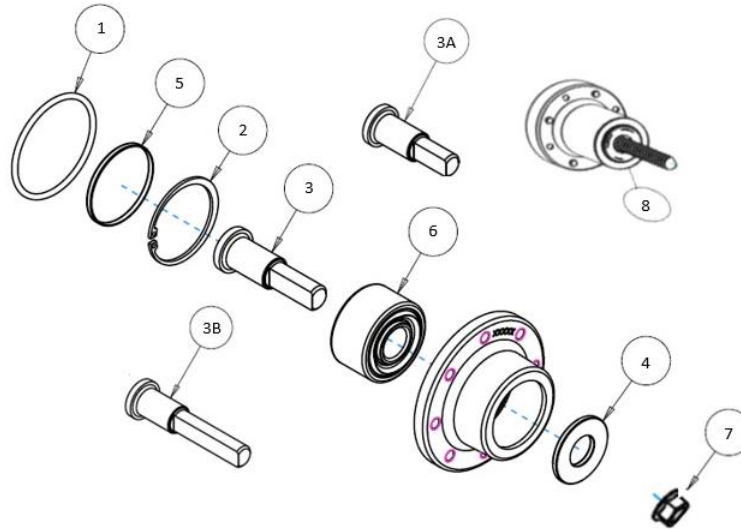

ITEM	PART #	DESCRIPTION	QTY
1	2550-074	O-RING 3.55MM X 56MM ID	1
2	2550-529	SNAP RING	1
3	2965-600A	SHAFT 73 MM (2965-500A HUB ASSEMBLY)	1
3A	2965-602A	SHAFT 66.7 MM (2965-502A HUB ASSEMBLY)	1
3B	2965-601A	SHAFT 98.4 MM (2965-501A HUB ASSEMBLY)	1
4	2965-604A	SPACER	1
5	2965-605A	CAP	1
6	2965-606	BEARING	1
7	2520-465	5/8-11 FLANGE HEX NUT GRADE 8	1
8	2965-500A	HUB ASSEMBLY 1.406" SPINDLE	1
	2965-501A	HUB ASSEMBLY 2.406" SPINDLE	1
	2965-502A	HUB ASSEMBLY 1.157" SPINDLE	1

OPTIONAL

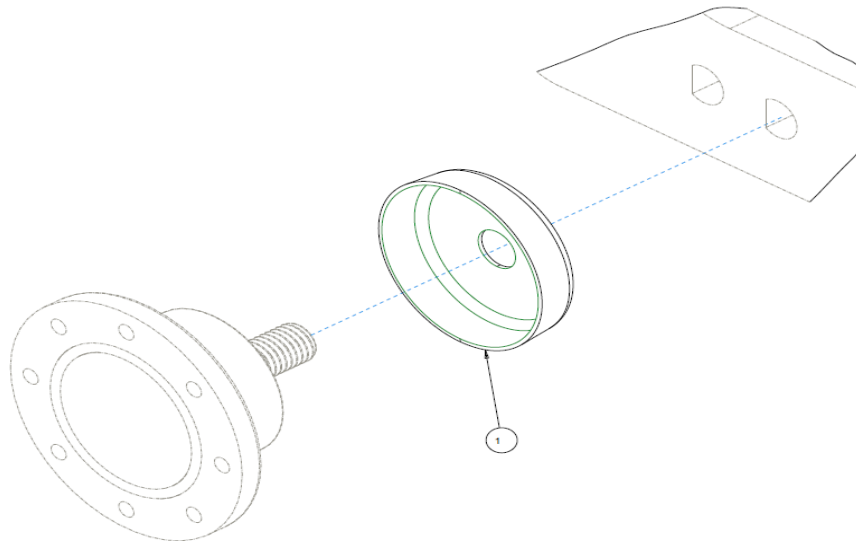

ITEM	PART NO.	DESCRIPTION	QTY
1	2965-550	BEARING SHIELD	1

PARTS IDENTIFICATION

2967-035A-ST-FW

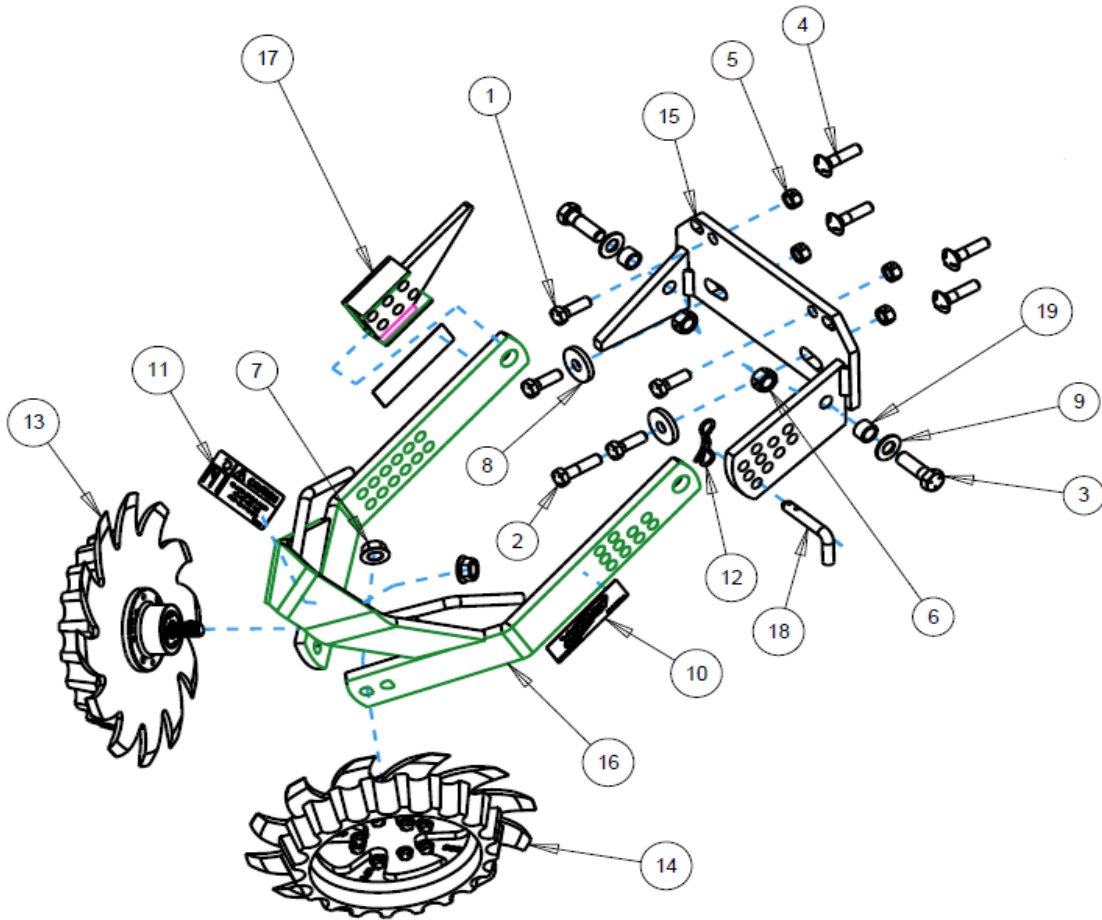

ITEM	PART NO.	DESCRIPTION	QTY
1	2502-294	1/2-13 X 1-1/2 HHCS GRADE 5	4
2	2502-351	1/2-13 x 2 HHCS GRADE 5	1
3	2502-391	5/8-11 x 2 HHCS GRADE 5	2
4	2505-345	1/2-13 X 2 CARRIAGE BOLT GRADE 5	4
5	2520-357	1/2-13 LOCK NUT GRADE A	4
6	2520-459	5/8-11 LOCK NUT GRADE B	2
7	2520-465	5/8-11 FLANGE NUT GRADE 8	2
8	2526-402	9/16 ID X 1-3/4 OD X 1/4 MACHINE WASHER	2
9	2526-453	5/8 SAE FLAT WASHER	2
10	2565-162	YETTER DECAL	2
11	2565-340	NOT A HANDLE DECAL	1
12	2570-448	BOW TIE COTTER PIN	1
13	2966-140-ST-FW	RIGHT HAND SHARK TOOTH WHEEL ASSEMBLY	1
14	2966-141-ST-FW	LEFT HAND SHARK TOOTH WHEEL ASSEMBLY	1
15	2967-281	MOUNT BRACKET	1
16	2967-282	ARM	1
17	2967-283	SLIDE	1
18	2984-326	PIN	1

PARTS IDENTIFICATION

2966-140-ST-FW

ITEM	PART NO.	DESCRIPTION	QTY
1	2502-220	5/16-18 X 3/4 HHFS GR5 ZP	4
2	2502-221	5/16-18 X 1 HHFS GR5 ZP	4
3	2515-562	13" WHEEL COVER, BLACK	2
4	2571-286	SHARKTOOTH WHEEL, 8 BOLT	1
5	2965-500	HUB ASSEMBLY, 1.406 SPINDLE	1
6	2967-560	FLOATER WHEEL	1

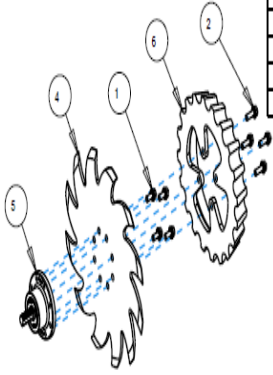

2966-140-ST-PFW

ITEM	PART NO.	DESCRIPTION	QTY
1	2502-220	5/16-18 X 3/4 HHFS GR5 ZP	4
2	2502-221	5/16-18 X 1 HHFS GR5 ZP	4
3	2571-286	SHARKTOOTH WHEEL, 8 BOLT	1
4	2965-500	HUB ASSEMBLY, 1.406 SPINDLE	1
5	2967-957	SHARKTOOTH TIMED FLOATER WHEEL	1

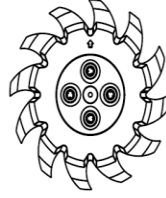

LINE UP ARROW ON FLOATER WITH SLOT ON WHEEL TO INSURE PROPER TIMING OF NOTCHES.

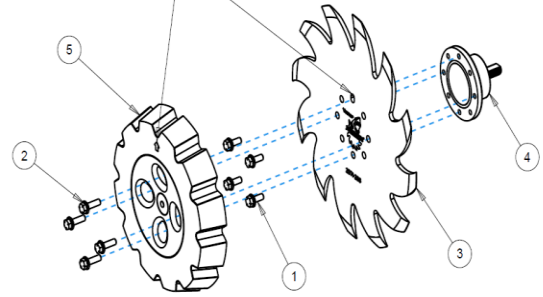

2966-140-BW-FW

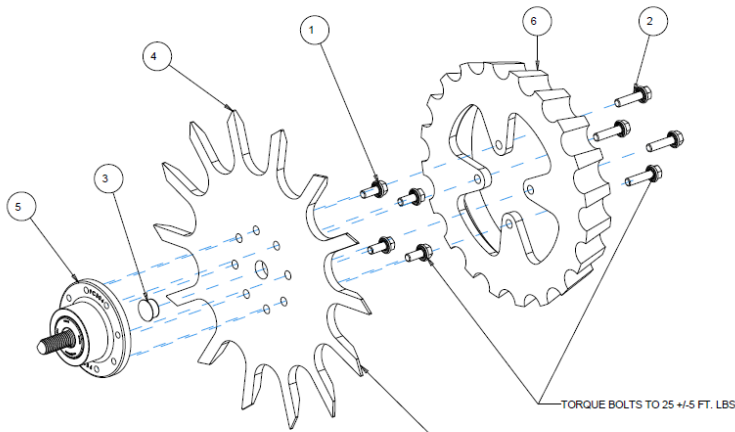

SCALE 0.500

ORIENTATION OF WHEEL DETERMINES RH ASSEMBLY

NOTE: BEVELS AWAY FROM HUB SIDE

ITEM	PART NO.	DESCRIPTION	QTY
1	2502-220	5/16-18 X 3/4 HHFS GR5 ZP	4
2	2502-222	5/16-18 X 1-1/4 HHFS GR5 ZP	4
3	2570-994	BEVEL WHEEL CENTER HOLE PLUG	1
4	2571-287-R	13" BEVEL WHEEL, 8 BOLT, RH	1
5	2965-500	HUB ASSEMBLY, 1.406 SPINDLE	1
6	2967-560	FLOATER WHEEL	1

PARTS IDENTIFICATION

2966-140-STF-PFW RIGHT HAND SHARKTOOTH FINGER WHEEL ASSEMBLY

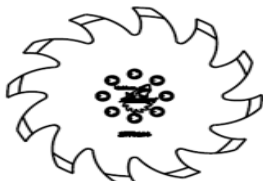
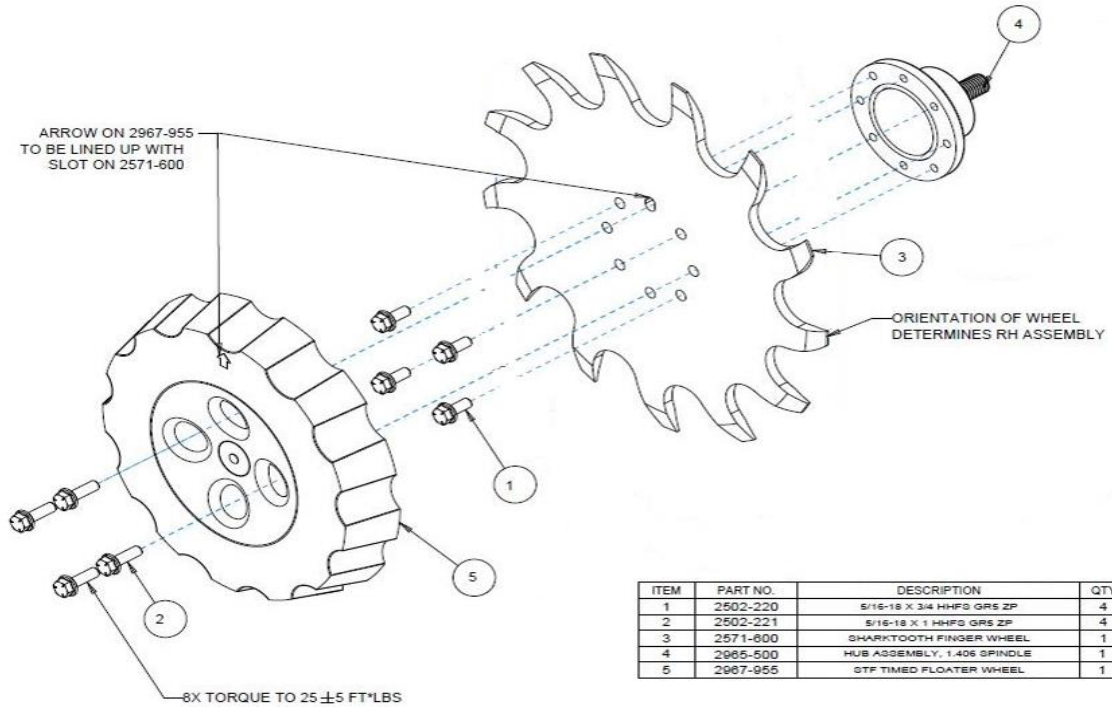

SHARKTOOTH WHEEL ASSEMBLY
RIGHT HAND 2966-140-ST(SHOWN)
LEFT HAND 2966-141-ST



SHARKTOOTH WHEEL ASSEMBLY W/FLOATER WHEEL
RIGHT HAND 2966-140-ST-FW(SHOWN)
LEFT HAND 2966-141-ST-FW

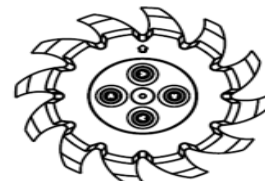

SHARKTOOTH WHEEL ASS'Y W/POLY FLOATER WHEEL
RIGHT HAND 2966-140-ST-PFW(SHOWN)
LEFT HAND 2966-141-ST-PFW

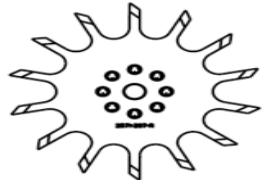

BEVEL WHEEL ASSEMBLY
RIGHT HAND 2966-140-BW(SHOWN)
LEFT HAND 2966-141-BW



BEVEL WHEEL ASSEMBLY W/FLOATER WHEEL
RIGHT HAND 2966-140-BW-FW(SHOWN)
LEFT HAND 2966-141-BW-FW

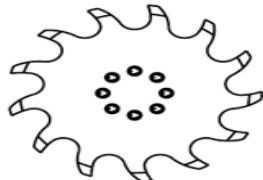

SHARKTOOTH FINGER WHEEL ASSEMBLY
RIGHT HAND 2966-140-STF(SHOWN)
LEFT HAND 2966-141-STF

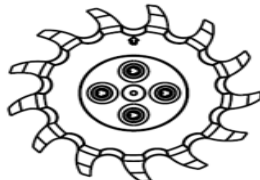

SHARKTOOTH FINGER WHEEL ASSEMBLY W/FLOATER WHEEL
RIGHT HAND 2966-140-STF-FW(SHOWN)
LEFT HAND 2966-141-STF-FW

ISO2966-140_ASSEMBLIES

FIELD SERVICE KITS

- 2965-119 - SERVICE KIT FOR 2570-740-2.812 D-BOLT
- 2965-120 - SERVICE KIT FOR 2570-742-3.812 D-BOLT
- 2965-121 - SERVICE KIT FOR 2570-766-2.562 D-BOLT

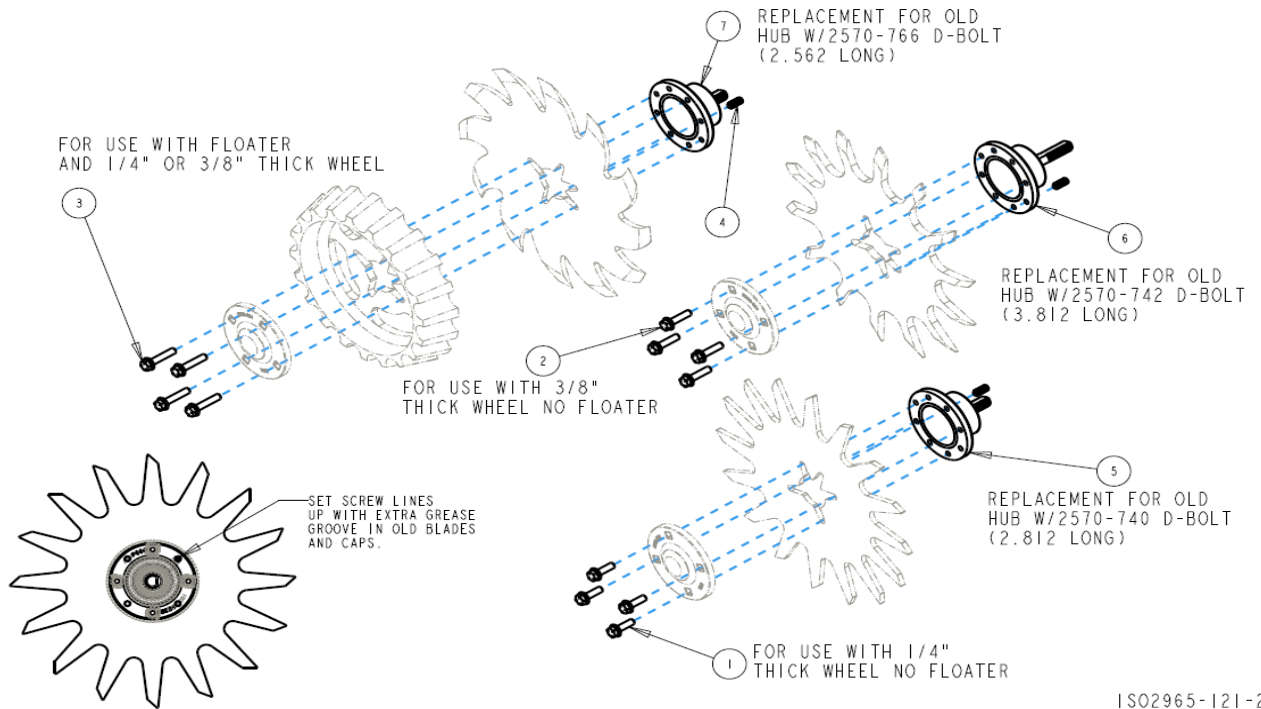

ISO2965-121-2

ITEM	PART NO	DESCRIPTION	QTY
1	2502-221	5/16-18 X 1 HHFS GRADE 5	4
2	2502-222	5/16-18 X 1-1/4 HHFS GRADE 5	4
3	2502-225	5/16-18 X 1-1/2 HHFS GRADE 5	4
4	2940-560	SET SCREW	1
5	2965-500	HUB ASSEMBLY 1.406 SPINDLE	1
6	2965-501	HUB ASSEMBLY 2.406 SPINDLE	1
7	2965-502	HUB ASSEMBLY 1.157 SPINDLE	1

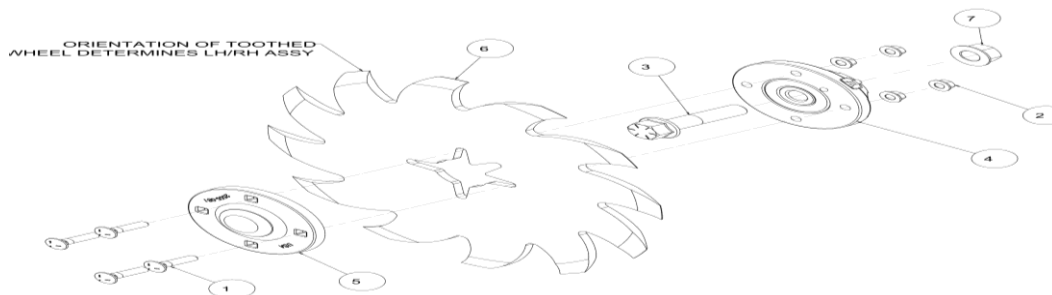

ITEM	PART NO	DESCRIPTION	QTY
1	2505-207	5/16-18 X 1-1/4 CARRIAGE HEAD BOLT GRADE 5	4
2	2520-206	5/16-18 FLANGE LOCK NUT	4
3	2570-740	D-BOLT FLANGE HEAD 5/8-11 X 2.812 GRADE 8	1
4	2965-128	HUB/BEARING ASSEMBLY	1
	2550-069	SEAL	1
	2570-594	BEARING	1
	2570-715	INSERT	1
	2965-351	HUB	1
	2533-110	GREASE FITTING	1
5	2965-352	HUB CAP	1
6	2967-602	SHARK TOOTH WHEEL	1
7	2520-465	5/8-11 FLANGE LOCK NUT GRADE 8	1



A Tradition of Solutions since 1930

Yetter Farm Equipment Co

PO BOX 358 109 S. McDonough

Colchester, IL 62326-0358

Phone: 309-776-4111

Toll Free: 800-447-5777

Email: info@yetterco.com

For updated models and manuals visit the Yetter website:

www.yetterco.com

© Yetter Farm Equipment Co. All Rights Reserved

2565-487_REV_M • 06/2026