

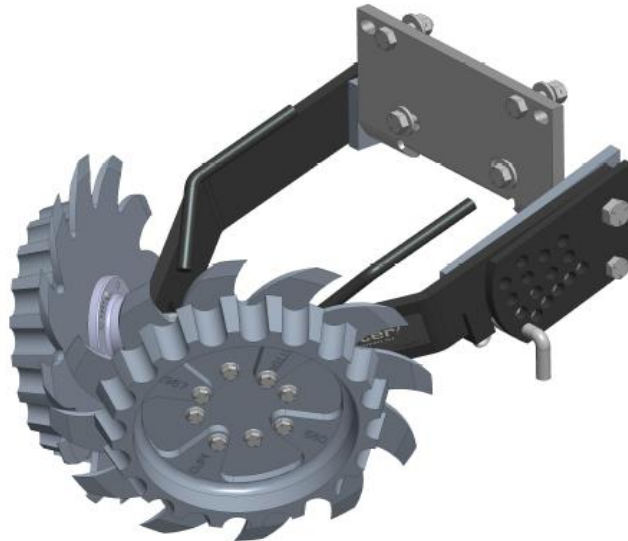

TITAN™
2967-033A, 2967-038A,
2967-039A, 2967-041A

RESIDUE MANAGER
OPERATOR'S MANUAL
PART IDENTIFICATION
2565-736_REV_I 12/2022



YETTER MANUFACTURING CO.
FOUNDED 1930

Colchester, IL 62326-0358
Toll free: 800/447-5777
309/776-3222 (Fax)
Website: www.yetterco.com
E-mail: info@yetterco.com

YETTER

FOREWORD

You've just joined an exclusive but rapidly growing club.

For our part, we want to welcome you to the group and thank you for buying a Yetter product.

We hope your new Yetter products will help you achieve both goals-increase your productivity and increase your efficiency so that you may generate more profit.

This operator's manual has been designed into four major sections: Foreword, Safety Precautions, Installation Instructions and Parts Breakdown.



This **SAFETY ALERT SYMBOL** indicates important safety messages in the manual. When you see this symbol, be alert to the possibility of **PERSONAL INJURY** and carefully read the message that follows.

The word **NOTE** is used to convey information that is out of context with the manual text. It contains special information such as specifications, techniques and reference information of a supplementary nature.

The word **IMPORTANT** is used in the text when immediate damage will occur to the machine due

to improper technique or operation. Important will apply to the same information as specified by note only of an immediate and urgent nature.

It is the responsibility of the user to read the operator's manual and comply with the safe and correct operating procedure and to lubricate and maintain the product according to the maintenance schedule in the operator's manual.

The user is responsible for inspecting his machine and for having parts repaired or replaced when continued use of the product would cause damage or excessive wear to the other parts.

It is the user's responsibility to deliver his machine to the Yetter dealer who sold him the product for service or replacement of defective parts, which are covered by the warranty policy.

If you are unable to understand or follow the instructions provided in this publication, consult your local Yetter dealer or contact:

YETTER MANUFACTURING CO.

309/776-4111

800/447-5777

309/776-3222 (FAX)

Website: www.yetterco.com

E-mail: info@yetterco.com

WARRANTY

Yetter Manufacturing warrants all products manufactured and sold by it against defects in material. This warranty being expressly limited to replacement at the factory of such parts or products as shall appear to be defective after inspection. This warranty does not obligate the Company to bear cost of labor in replacement of parts. It is the policy of the Company to make improvements without incurring obligations to add them to any unit already sold. No warranty is made or authorized to be made, other than herein set forth. This warranty is in effect for one year after purchase.

DEALER: _____

Yetter Manufacturing warrants its own products only and cannot be responsible for damages to equipment on which mounted.

SAFETY

A brief description of signal words that may be used in this manual:

CAUTION: Used as a general reminder of good safety practices or to direct attention to unsafe practices.

WARNING: Denotes a specific potential hazard.

DANGER: Denotes the most serious specific potential hazard.

SAFETY PRECAUTIONS

You can make your farm a safer place to live and work if you observe the safety precautions given. Study these precautions carefully and insist that those working with you and for you follow them.

Finally, remember this: an accident is usually caused by someone's carelessness, neglect or oversight.



WARNING

Never clean, lubricate or adjust a machine that is in motion. Always lower or block the implement before performing service.

If the machine must be serviced in the raised position, jack or block it up to prevent it from accidentally falling and injuring someone.

Do not allow riders on the tractor or implement.

Use speeds and caution dictated by the terrain being traversed. Do not operate on any slope steep enough to cause tipping or loss of control.

Be sure all personnel are clear of the immediate area before operating.

Read and understand the operator's manual and require all other persons who will operate the equipment to do the same.

Be familiar with all tractor and implement controls and be prepared to stop engine and implements quickly in an emergency.



CAUTION

Consult your implement and tractor operator's manual for correct and safe operating practices.

Beware of towed implement width and allow safe clearance.

FAILURE TO HEED MAY RESULT IN PERSONAL INJURY OR DEATH.

TABLE OF CONTENTS

Introduction.....	pg.2
Warranty.....	pg.2
Safety Information.....	pg.3
Bolt Torque.....	pg.5
Installation Instruction.....	pg.6-7
Operation.....	pg.8-9
Maintenance.....	pg.9
Parts Identification.....	pg.10-17

BOLT TORQUE

Mounting bolts and hardware

Before operating the Titan™ Residue Manager for the first time, check to be sure that all hardware is tight. Check all hardware again after approximately 50 hours of operation and at the beginning of each planting season.

All hardware used on the Titan™ Residue Manager is Grade 5 unless otherwise noted. Grade 5 cap screws are marked with three radial lines on the head. If hardware must be replaced, be sure to replace it with hardware of equal size, strength and thread type. Refer to the torque values chart when tightening hardware.



Important: Over tightening hardware can cause as much damage as when under tightening. Tightening hardware beyond the recommended range can reduce its shock load capacity.

The chart below is a guide for proper torque. Use it unless a specified torque is called out elsewhere in the manual.

Torque is the force you apply to the wrench handle or the cheater bar, times the length of the handle or bar.

Use a torque wrench whenever possible.

The following table shows torque in ft. lbs. for coarse thread hardware.

BOLT DIA. AND THREADS PER INCH	GRADE 2		GRADE 5 OR A-325		GRADE 8	
1/4	6		10		14	
5/16	12		20		30	
3/8 - 16	25		35		50	
7/16 - 14	35		55		80	
1/2 - 13	55		85		125	
9/16 - 12	75		125		175	
5/8 - 11	105		170		235	
3/4 - 10	185		305		425	
7/8 - 9	170		445		690	
1-8	260		670		1030	
1 1/8 - 7	365		900		1460	
1 1/4 - 7	515		1275		2060	
1 3/8 - 6	675		1675		2700	
1 1/2 - 6	900		2150		3500	
1 3/4 - 5	1410		3500		5600	

Lubricate all bearings and moving parts as assembled and make certain that they work freely.



WARNING: Never work around the toolbar/implement while in a raised position without using safety lockups.



CAUTION: The Residue manager attachments are very heavy. Pay extra attention to lifting techniques while handling and or maneuvering the opener during assembly. Failure to do so may lead to personal injury.

INSTALLATION INSTRUCTIONS

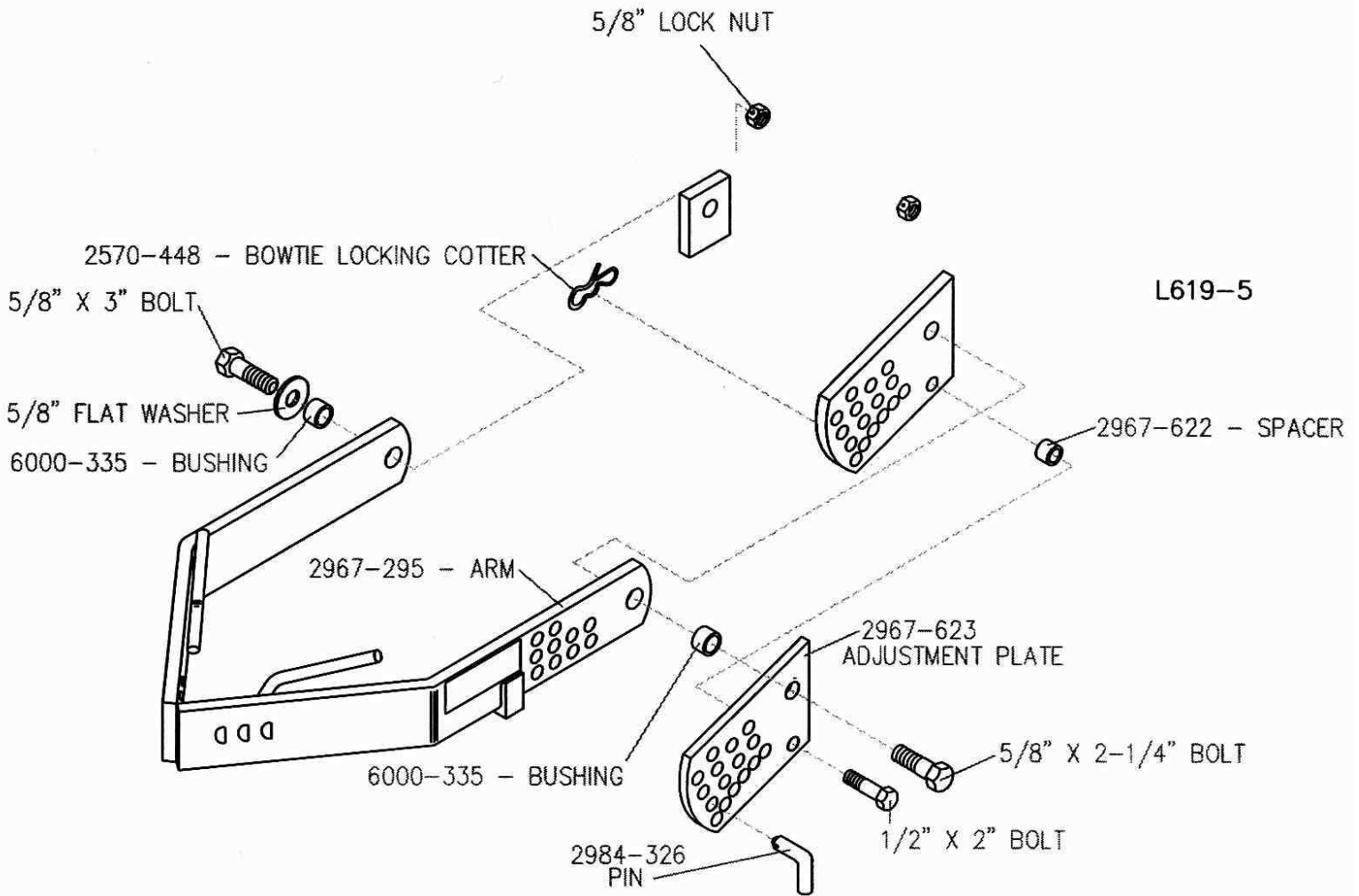

STEP 1. Attach the 2967-295 arm to the 2967-296-mount bracket using the 5/8" bolts, flat washers, bushings, 2967-623 adjustment plate and 5/8" lock nuts. Also, install the 1/2" x 2" bolt, 2967-622 spacer, 1/2" lock nut, 2984-326 pin and 2570-446 bowtie cotter on the 2967-623 adjustment plate.

INSTALLATION INSTRUCTIONS

STEP 2 Choose the mounting hole in which to attach the R.M. wheels.

Attach the R.M. wheel/hub assemblies to the 2967-295 Combo Arm using 5/8" lock washers and hex nuts. Adjust the bearing shield to top dead center, rotate slightly forward. Torque to 150 ft./lbs.

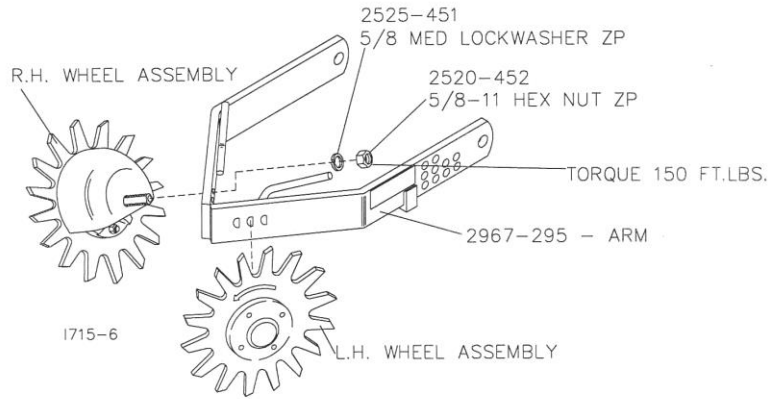

REVISED 02/06/09

MOUNTING CONFIGURATIONS FOR RESIDUE WHEELS

- 2967-404 – 13" TAPER TOOTH SPOKE WHEEL
- 2967-596 – 3/8" HEAVY DUTY SPOKE WHEEL
- 2967-602 – 13" SHARKTOOTH WHEEL
- 2967-388 – 10" TAPER TOOTH SPOKE WHEEL

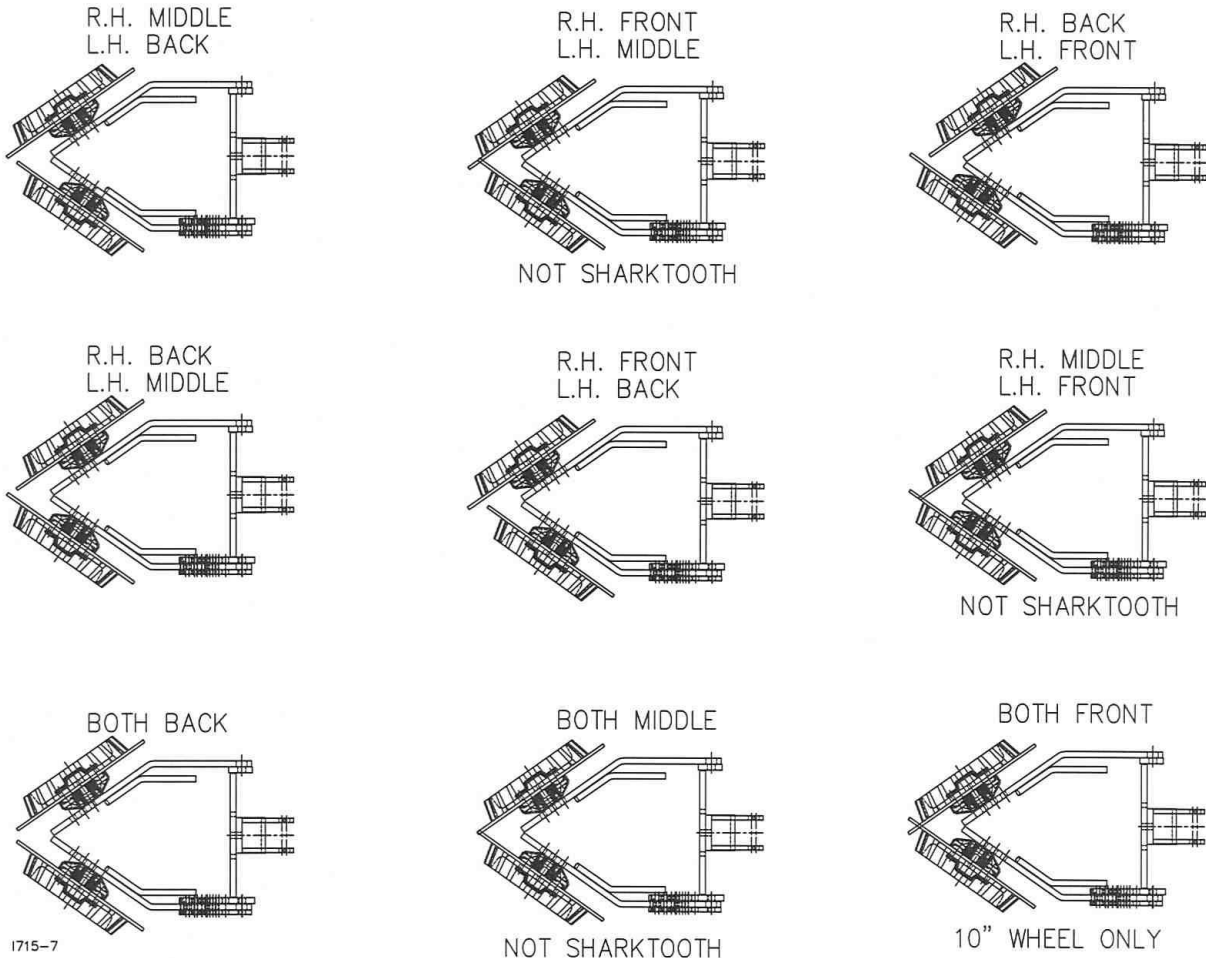

OPERATION



CAUTION: Where rocks are present the residue manager should be set in the “float” position, not locked down.

Adjust the residue manager to move crop residue aside and not move any soil. Adjustments to the residue manager may have to be made when changing field conditions and type and amount of residue. Use the handle for leverage when changing depth settings.

“FLOAT SETTINGS”

Install the adjustment pin below the combo arm.

To raise the wheels, lift the 2967-295 and move the adjustment pin up.

To lower the wheels, move the adjustment pin down.

“RIGID SETTING”

Install the adjustment pin through the combo arm.

To raise the wheels, lift the 2967-295-combo arm to the desired position and insert the pin.

To lower the wheels, lower the combo arm to the desired position and insert the pin.

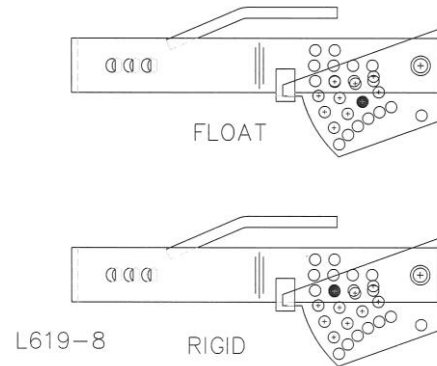

ROW CLEANER DO'S AND DON'TS

1. **DO NOT** move soil; Residue Managers are designed to move crop residue only.
2. **DO NOT** operate at slow speeds, ground speed affects how aggressive the spoke wheels are; operate at sufficient speed (4-6 mph) to maintain good residue flow.
3. **DO NOT** expect 100% of crop residue to be cleared, it is not necessary and would necessitate engaging the soil. The width of path cleared depends on ground conditions, depth setting and ground speed.
4. **DO** expect to see wheels occasionally quit turning, indicates ideal (shallow) setting which is not moving soil.
5. **DO** adjust toolbar frame height and drawbar to “level” correctly. Very important to ensure residue manager will follow ground contours properly.

OPERATION



IMPORTANT: Please check the amount of travel that the Residue Manager has before going to the field.



IMPORTANT: Check for clearance with the residue manager wheels. If the residue manager wheels can make contact with the frame, tires, or hitch the Titan™ Residue Manager could be damaged.

Level applicator as shown below.

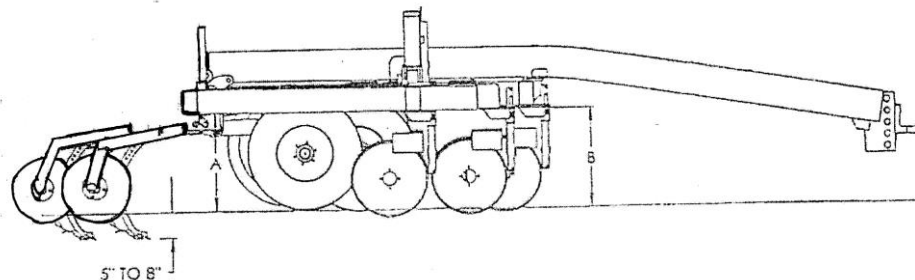

Once the knives are at the desired depth, the machine must be leveled. A low front end will cause the front knives to be in the ground deeper than the rear knives. With the knives in the soil, measure distance “A” and “B” from level ground to the bottom of the frame – THIS DISTANCE MUST BE THE SAME. Once the distance is obtained, step back approximately 50 feet and view the machine. The applicator should appear level to the ground. If not, make certain the ground is level. The applicator can be leveled by changing the position of the hitch clevis.

Set the coulters depth. The coulters are adjusted independent of the A. A. knives. Loosen the set screws on the mounting bracket and slide the coulters shaft up or down to the desired height.

Do not run the coulters any deeper than what is needed to cut the residue. Running the coulters deeper than necessary increases coulters wear. Coulters set too deep will decrease berm height by prefabricating the soil in front of the knife.

MAINTENANCE

Regularly inspect the residue manager for loose or worn parts. Repair and replace as needed.

Storing the Equipment

Store the machine in an area away from human activity

Store machine in RAISED position.

Install service locks on all wheel cylinders.

At the end of the season, the machine should be thoroughly inspected and prepared for storage. Repair or replace any worn or damaged components to prevent down time at the start of the next season. Store machine under cover with all parts in operating condition.

- Clean machine thoroughly to remove all dirt, debris and crop residue, which would hold moisture and cause rusting.
- Inspect machine for worn or broken parts. See your Yetter Farm Equipment dealer during the off-season so that parts or service can be acquired when machine is not needed in the field.
- Lubricate bearings as outlined in the Lubrication section
- Paint all parts which are chipped or worn and require repainting.
- Store machine in a clean, dry place with the planting unit out of the sun.
- If the machine cannot be stored inside, cover with a waterproof tarpaulin and tie securely in place.
- Do not allow children to play on or around the machine

PARTS IDENTIFICATION

2966-140-ST-FW

ITEM	PART NO.	DESCRIPTION	QTY
1	2502-220	5/16-18 X 3/4 HHFS GR5 ZP	4
2	2502-221	5/16-18 X 1 HHFS GR5 ZP	4
3	2515-562	13" WHEEL COVER, BLACK	2
4	2571-286	SHARKTOOTH WHEEL, 8 BOLT	1
5	2965-500	HUB ASSEMBLY, 1.406 SPINDLE	1
6	2967-560	FLOATER WHEEL	1

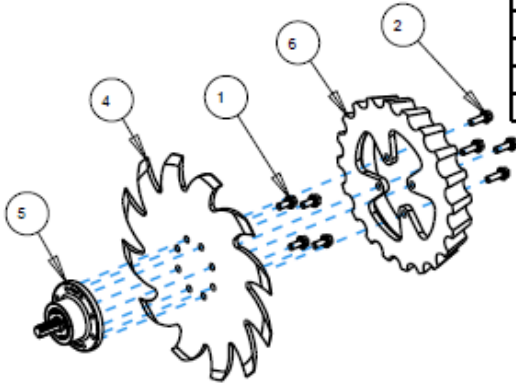

2966-140-BW-FW

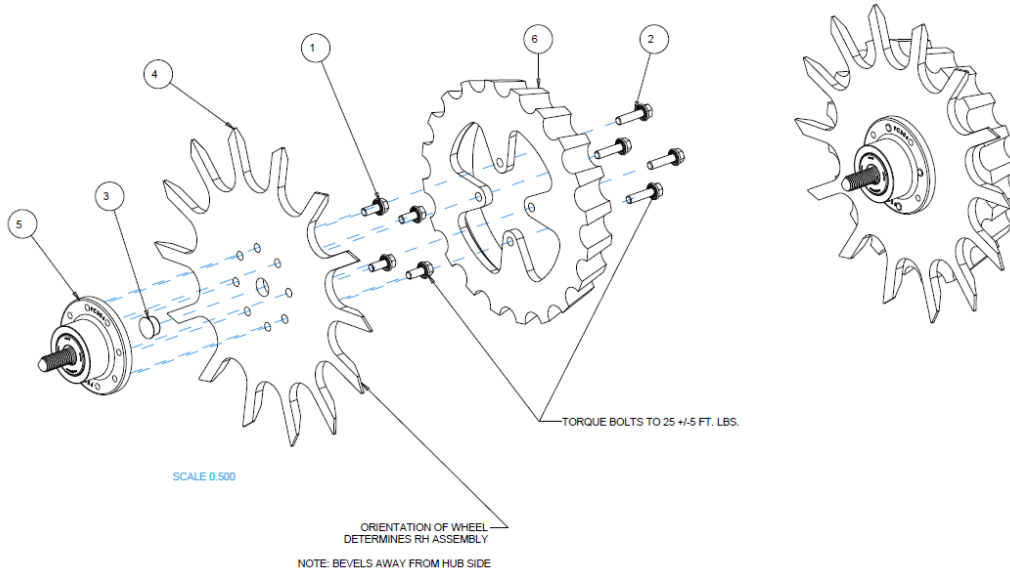

ITEM	PART NO.	DESCRIPTION	QTY
1	2502-220	5/16-18 X 3/4 HHFS GR5 ZP	4
2	2502-222	5/16-18 X 1-1/4 HHFS GR5 ZP	4
3	2570-994	BEVEL WHEEL CENTER HOLE PLUG	1
4	2571-287-R	13" BEVEL WHEEL, 8 BOLT, RH	1
5	2965-500	HUB ASSEMBLY, 1.406 SPINDLE	1
6	2967-560	FLOATER WHEEL	1

PARTS IDENTIFICATION

2966-140-STF-FW RIGHT HAND SHARKTOOTH FINGER WHEEL ASSEMBLY

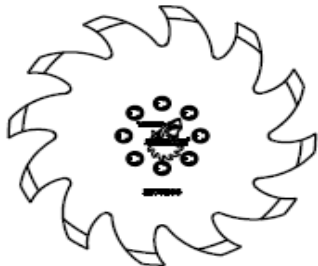
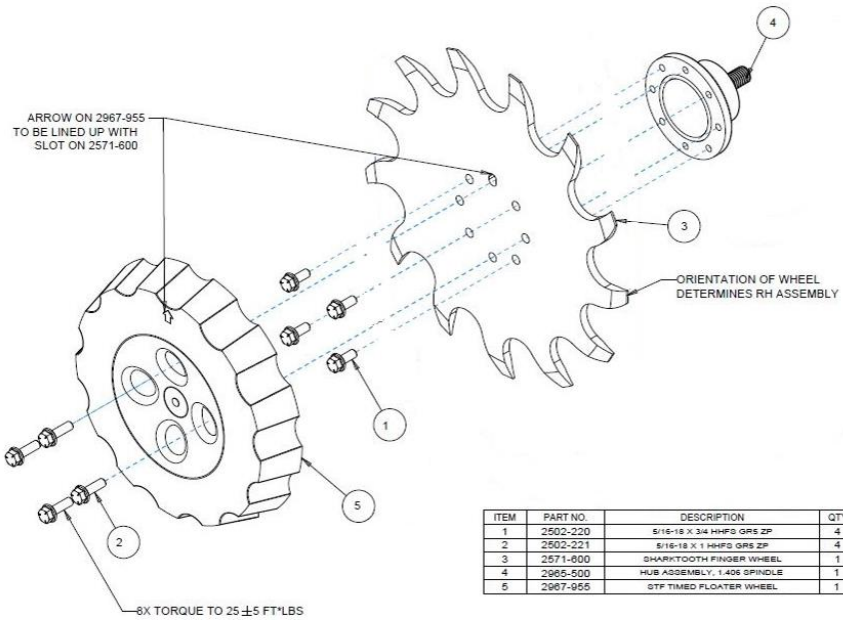

SHARKTOOTH WHEEL ASSEMBLY
RIGHT HAND 2966-140-ST(SHOWN)
LEFT HAND 2966-141-ST



SHARKTOOTH WHEEL ASSEMBLY W/FLOATER WHEEL
RIGHT HAND 2966-140-ST-FW(SHOWN)
LEFT HAND 2966-141-ST-FW

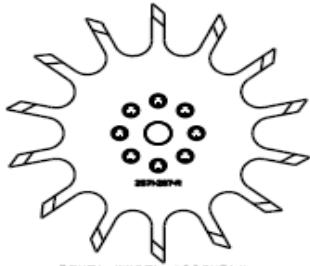

BEVEL WHEEL ASSEMBLY
RIGHT HAND 2966-140-BW(SHOWN)
LEFT HAND 2966-141-BW

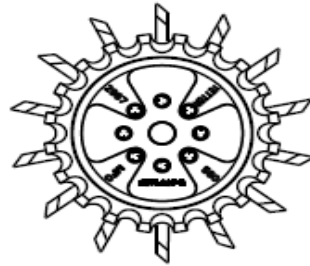

BEVEL WHEEL ASSEMBLY W/FLOATER WHEEL
RIGHT HAND 2966-140-BW-FW(SHOWN)
LEFT HAND 2966-141-BW-FW

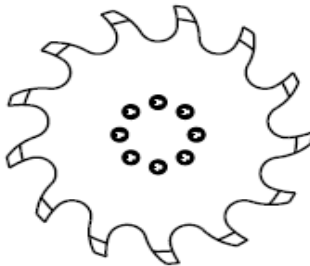

SHARKTOOTH FINGER WHEEL ASSEMBLY
RIGHT HAND 2966-140-STF(SHOWN)
LEFT HAND 2966-141-STF

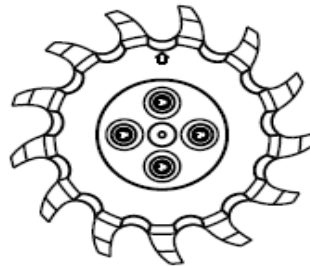

SHARKTOOTH FINGER WHEEL ASSEMBLY W/FLOATER WHEEL
RIGHT HAND 2966-140-STF-FW(SHOWN)
LEFT HAND 2966-141-STF-FW

ISO2966-140_ASSEMBLIES

PARTS IDENTIFICATION

2967-033A-ST-FW

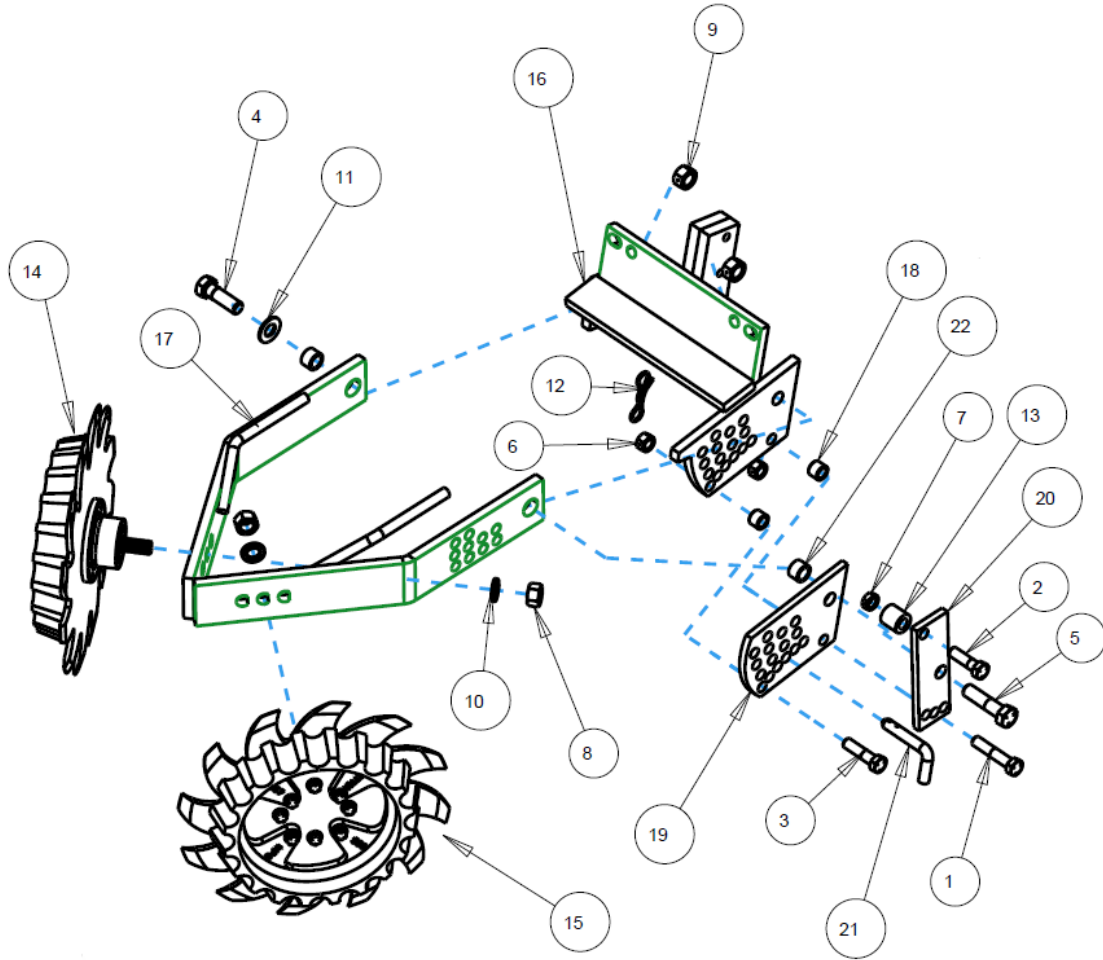

ITEM	PART NO.	DESCRIPTION	QTY
1	2502-296	1/2-13 X 2-1/2 HHCS GR5 ZP	1
2	2502-317	1/2-13 X 1-3/4 HHCS GR5 ZP	1
3	2502-351	1/2-13 X 2 HHCS GR.5 ZP	1
4	2502-391	5/8-11 X 2 HHCS GR 5 ZP	1
5	2502-393	5/8-11 X 2 1/2 HHCS GR5 ZP	1
6	2520-357	1/2-13 LOCK HEX NUT, GR A, ZP	2
7	2520-364	1/2-13 HEX LOCKNUT, JAM	1
8	2520-452	5/8-11 HEX NUT GR 8 ZP	2
9	2520-459	5/8-11 LOCK HEX NUT, GR B, ZP	2
10	2525-451	5/8 MED. LOCKWASHER ZP.	2
11	2526-453	5/8 SAE FLATWASHER ZP	1
12	2570-448	.120 BOWTIE LOCKING COTTER ZP	1
13	2960-372	SPRING STOP, ZYD	1
14	2966-140-ST-FW	SHRKTH ASSY,RH,3"D-BOLT FLT WL	1
15	2966-141-ST-FW	SHRKTH ASSY,LH,3"D-BOLT FLT WL	1
16	2966-225	RM ADJ BRKT W/MOUNTING W.A.	1
17	2966-265	UNIVERSAL COMBO ARM W.A.	1
18	2967-622	9/16" SPACER ZP	2
19	2967-623	ADJUSTING PLATE BACKER	1
20	2967-773	UPSTOP PLATE	1
21	2984-326	R.M. UPSTOP PIN ZP	1
22	6000-335	9/16" BUSHING	2

PARTS IDENTIFICATION

2967-038A-ST-FW

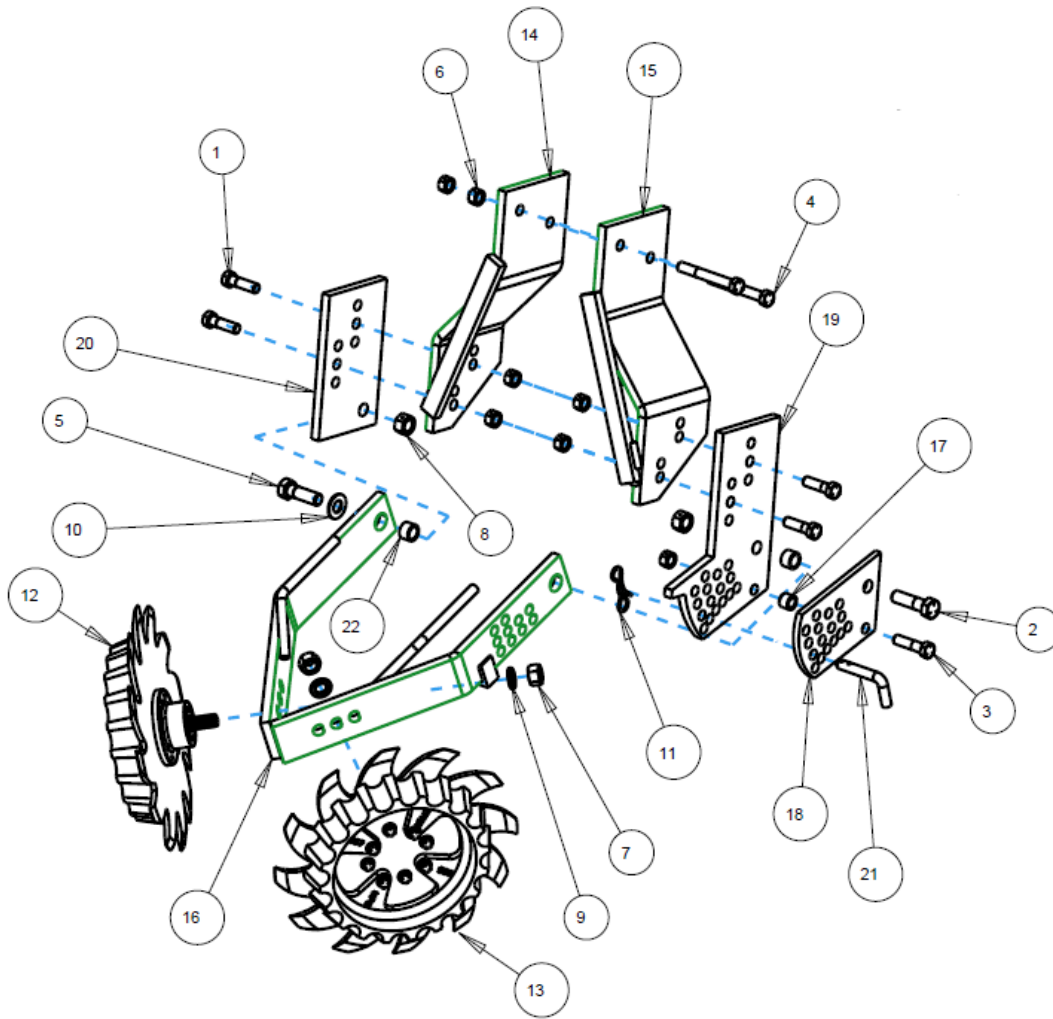

ITEM	PART NO.	DESCRIPTION	QTY
1	2502-317	1/2-13 X 1-3/4 HHCS GR5 ZP	4
2	2502-332	5/8-11 X 2-1/4 HHCS GR5 ZP	1
3	2502-351	1/2-13 X 2 HHCS GR.5 ZP	1
4	2502-365	1/2-13 X 3-3/4 HHCS GR5 ZP	2
5	2502-391	5/8-11 X 2 HHCS GR 5 ZP	1
6	2520-357	1/2-13 LOCK HEX NUT, GR A, ZP	7
7	2520-452	5/8-11 HEX NUT GR 8 ZP	2
8	2520-459	5/8-11 LOCK HEX NUT, GR B, ZP	2
9	2525-451	5/8 MED. LOCKWASHER ZP.	2
10	2526-453	5/8 SAE FLATWASHER ZP	1
11	2570-448	.120 BOWTIE LOCKING COTTER ZP	1
12	2966-140-ST-FW	SHRKTH ASSY,RH,3"D-BOLT FLT WL	1
13	2966-141-ST-FW	SHRKTH ASSY,LH,3"D-BOLT FLT WL	1
14	2966-226	R.H. MOUNT BRACKET W.A.	1
15	2966-227	L.H. MOUNT BRACKET W.A.	1
16	2967-295	COMBO ARM WA, CASE TITAN	1
17	2967-622	9/16" SPACER ZP	1
18	2967-623	ADJUSTING PLATE BACKER	1
19	2967-693	ADJUSTMENT BRACKET, L.H.	1
20	2967-694	ADJUSTMENT BRACKET, R.H.	1
21	2984-326	R.M. UPSTOP PIN ZP	1
22	6000-335	9/16" BUSHING	2

PARTS IDENTIFICATION 2967-039A-ST-FW

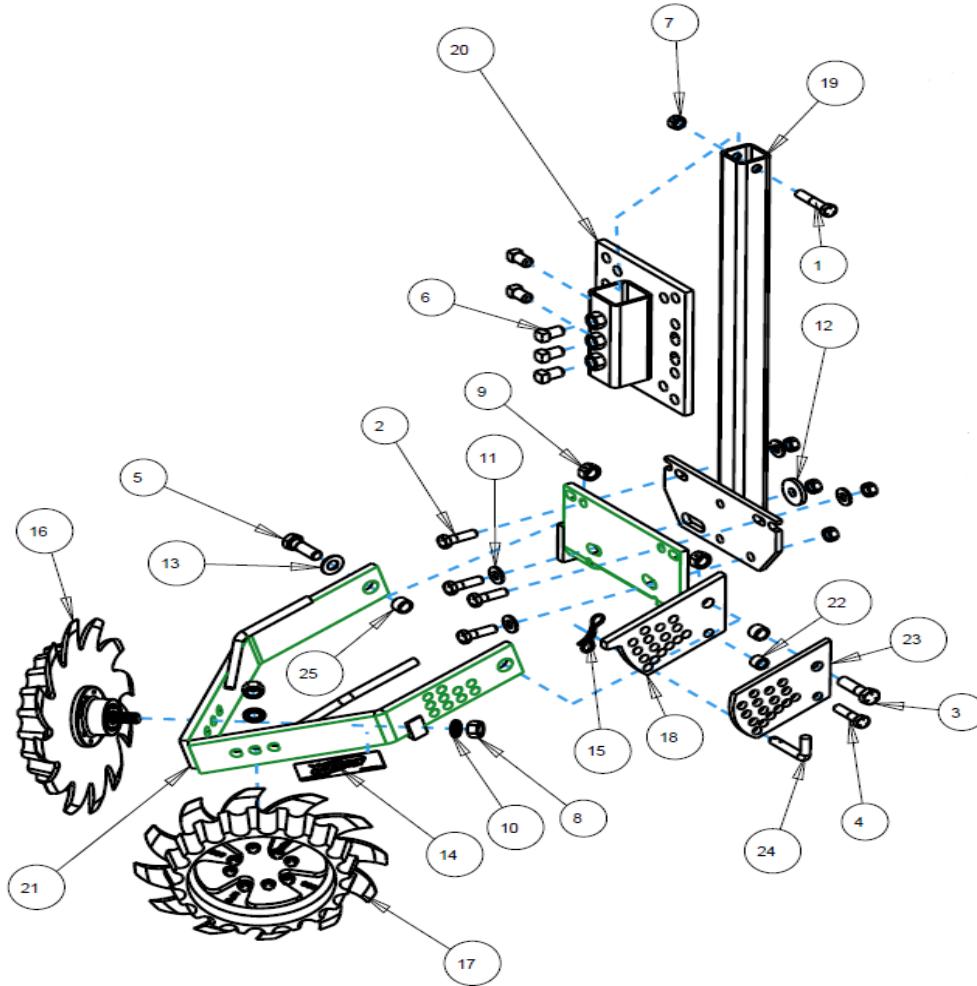

ITEM	PART NO.	DESCRIPTION	QTY
1	2502-296	1/2-13 X 2-1/2 HHCS GR5 ZP	1
2	2502-317	1/2-13 X 1-3/4 HHCS GR5 ZP	4
3	2502-332	5/8-11 X 2-1/4 HHCS GR5 ZP	1
4	2502-351	1/2-13 X 2 HHCS GR.5 ZP	1
5	2502-391	5/8-11 X 2 HHCS GR 5 ZP	1
6	2503-379	5/8-11 X 1 SQ. HCPSS GR5ZP	5
7	2520-357	1/2-13 LOCK HEX NUT, GR A, ZP	6
8	2520-452	5/8-11 HEX NUT GR 8 ZP	2
9	2520-459	5/8-11 LOCK HEX NUT, GR B, ZP	2
10	2525-451	5/8 MED. LOCKWASHER ZP.	2
11	2526-355	1/2 FLAT WASHER HARD'ND ZP	4
12	2526-402	9/16ID X 1-3/4 OD X 1/4MBZP	1
13	2526-453	5/8 SAE FLATWASHER ZP	1
14	2565-162	YETTER DECAL	2
15	2570-448	.120 BOWTIE LOCKING COTTER ZP	1
16	2966-140-ST-FW	SHRKT ASSY,RH,3"D-BOLT FLT WL	1
17	2966-141-ST-FW	SHRKT ASSY,LH,3"D-BOLT FLT WL	1
18	2966-237	RM ADJ BRACKET SUB-W.A.	1
19	2966-245	MOUNTING BRKT., SHANK W.A.	1
20	2967-289	FRAME MNTD. RM MOUNT BRKT. W.A.	1
21	2967-295	COMBO ARM WA, CASE TITAN	1
22	2967-622	9/16" SPACER ZP	1
23	2967-623	ADJUSTING PLATE BACKER	1
24	2984-326	R.M. UPSTOP PIN ZP	1
25	6000-335	9/16" BUSHING	2

PARTS IDENTIFICATION

2967-041A-ST-FW

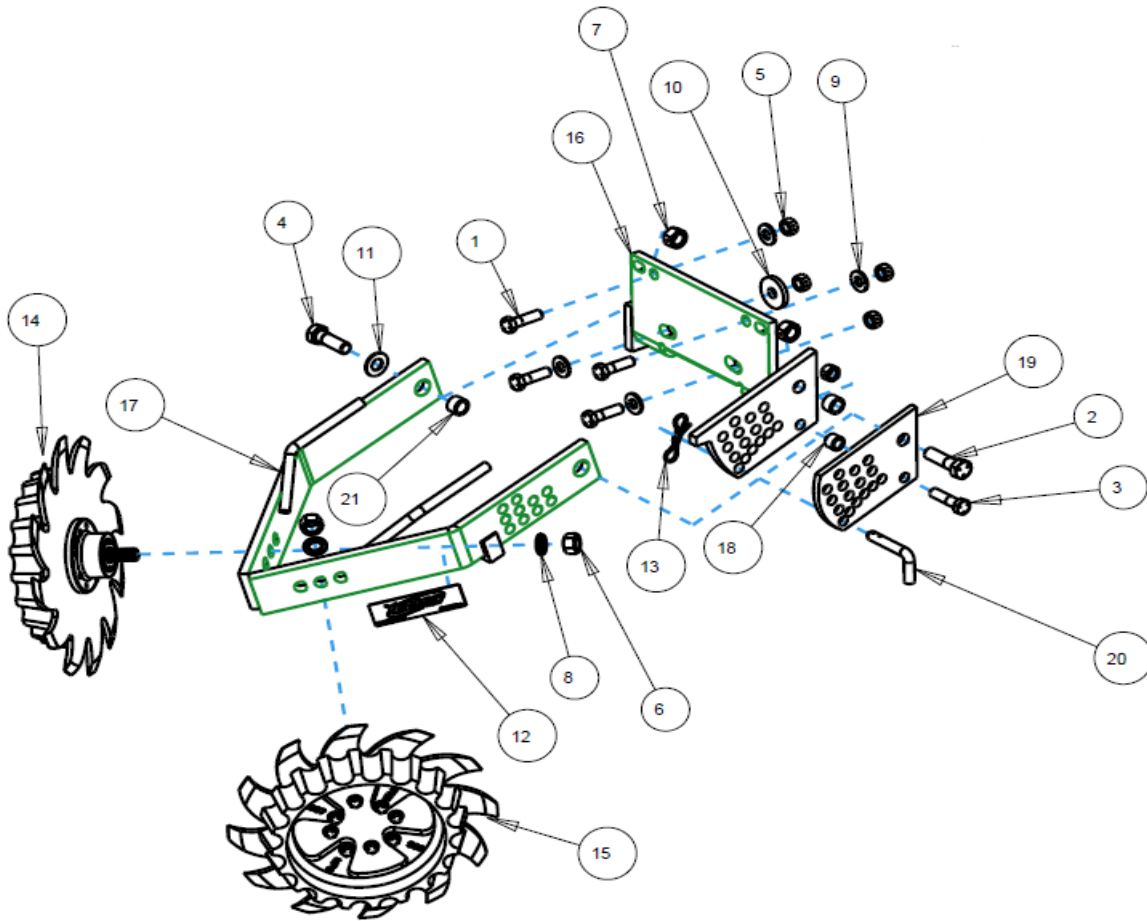

ITEM	PART NO.	DESCRIPTION	QTY
1	2502-317	1/2-13 X 1-3/4 HHCS GR5 ZP	4
2	2502-332	5/8-11 X 2-1/4 HHCS GR5 ZP	1
3	2502-351	1/2-13 X 2 HHCS GR.5 ZP	1
4	2502-391	5/8-11 X 2 HHCS GR 5 ZP	1
5	2520-357	1/2-13 LOCK HEX NUT, GR A, ZP	5
6	2520-452	5/8-11 HEX NUT GR 8 ZP	2
7	2520-459	5/8-11 LOCK HEX NUT, GR B, ZP	2
8	2525-451	5/8 MED. LOCKWASHER ZP.	2
9	2526-355	1/2 FLAT WASHER HARD'ND ZP	4
10	2526-402	9/16ID X 1-3/4 OD X 1/4MBZP	1
11	2526-453	5/8 SAE FLATWASHER ZP	1
12	2565-162	YETTER DECAL	2
13	2570-448	.120 BOWTIE LOCKING COTTER ZP	1
14	2966-140-ST-FW	SHRKTH ASSY,RH,3"D-BOLT FLT WL	1
15	2966-141-ST-FW	SHRKTH ASSY,LH,3"D-BOLT FLT WL	1
16	2966-237	RM ADJ BRACKET SUB-W.A.	1
17	2967-295	COMBO ARM WA, CASE TITAN	1
18	2967-622	9/16" SPACER ZP	1
19	2967-623	ADJUSTING PLATE BACKER	1
20	2984-326	R.M. UPSTOP PIN ZP	1
21	6000-335	9/16" BUSHING	2

PARTS IDENTIFICATION

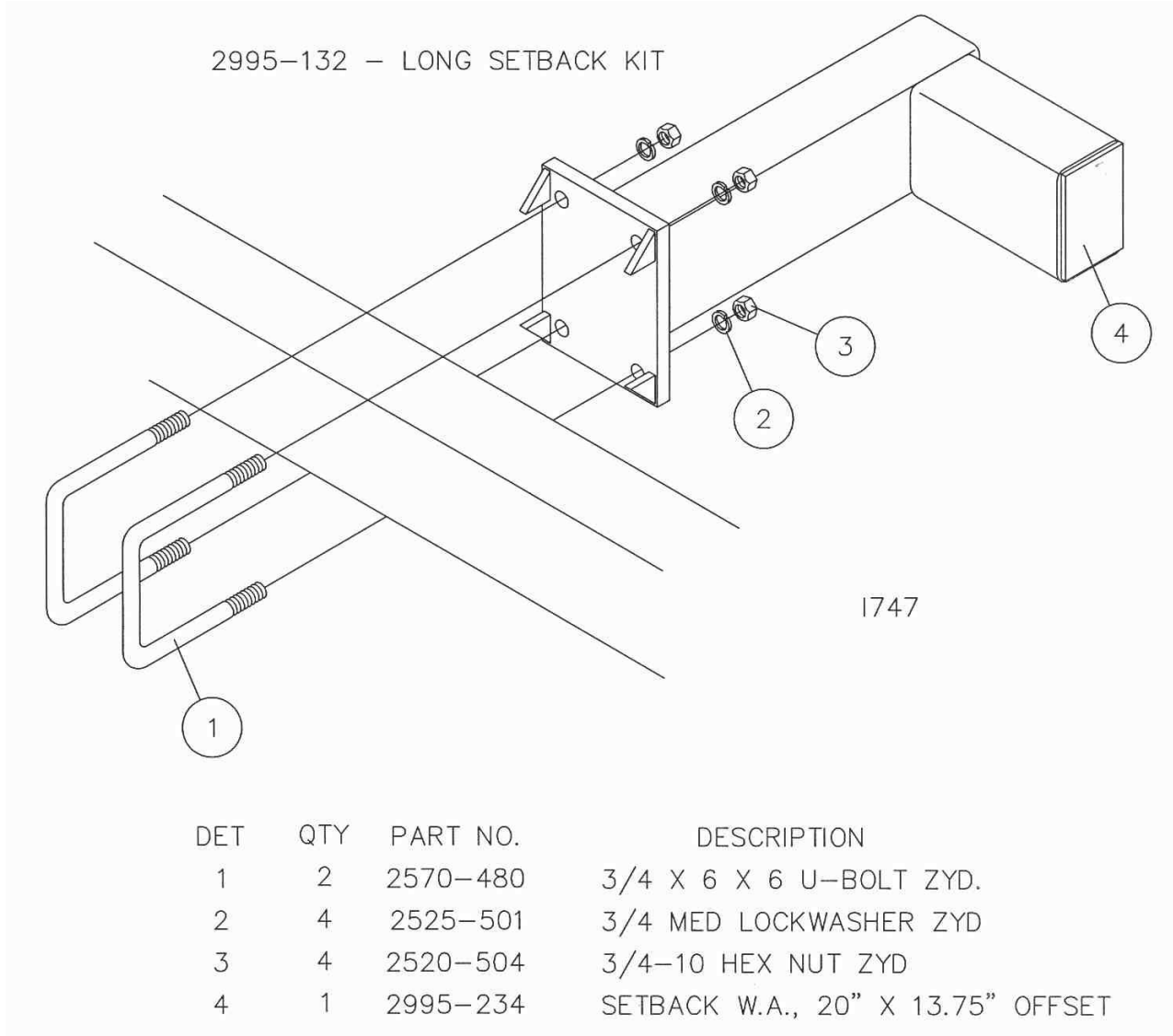

PARTS IDENTIFICATION

2995-133 - SHORT SETBACK KIT

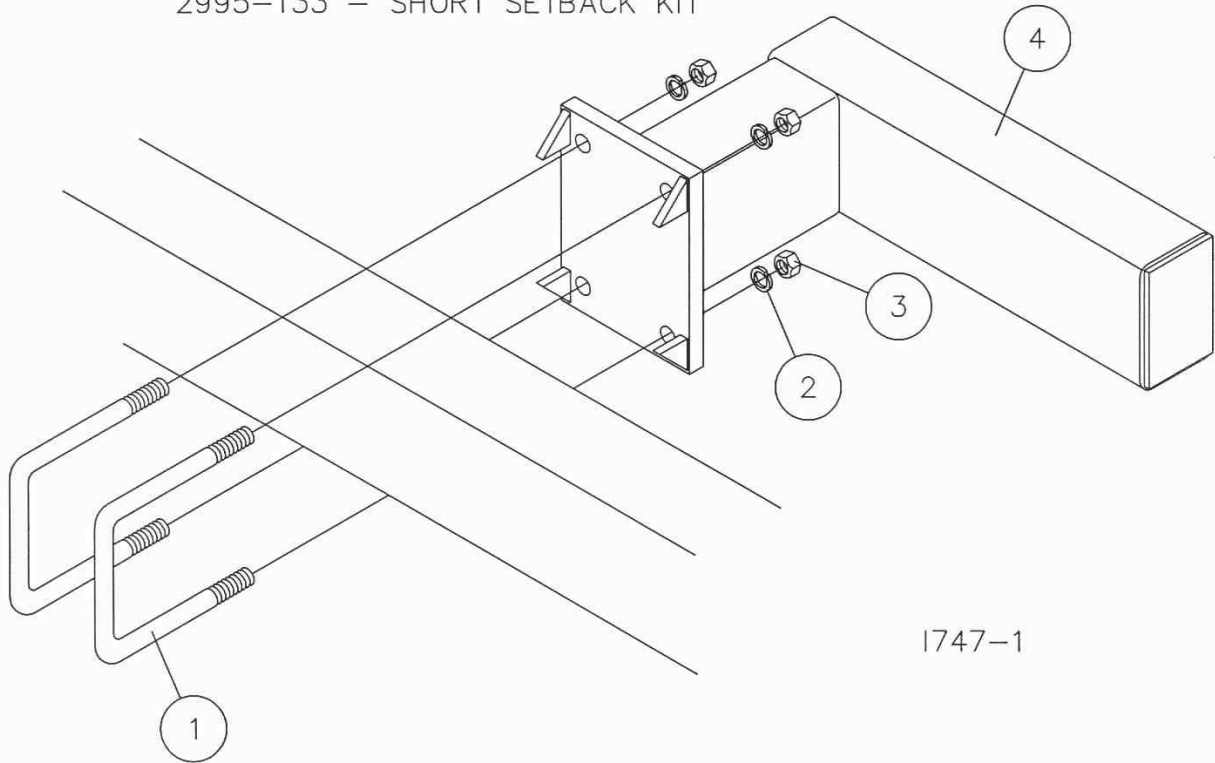

DET	QTY	PART NO.	DESCRIPTION
1	2	2570-480	3/4 X 6 X 6 U-BOLT ZYD.
2	4	2525-501	3/4 MED LOCKWASHER ZYD
3	4	2520-504	3/4-10 HEX NUT ZYD
4	1	2995-233	SETBACK W.A., 13.75" X 20" OFFSET

NOTES

NOTES



A Tradition of Solutions since 1930

Yetter Farm Equipment Co

PO BOX 358 109 S. McDonough

Colchester, IL 62326-0358

Phone: 309-776-4111

Toll Free: 800-447-5777

Email: info@yetterco.com

For updated models and manuals visit the Yetter website:

www.yetterco.com

© Yetter Farm Equipment Co. All Rights Reserved

2565-736_REV_I • 12/2022