



TITAN™ SERIES

2967-029B / 2967-029B-PP SHORT U.N.T.™
2967-097B SHORT U.N.T.™ CNH
RESIDUE MANAGER

Owner's Manual
Part Identification
2565-696_Rev_K - 07/2021



YETTER MANUFACTURING CO.
Founded 1930

Colchester, IL 62326
Toll Free: (800)447-5777
Fax: (309)776-3222
Website: yetterco.com
E-mail: info@yetterco.com

YETTER

Table of Contents

| | |
|--|--------------|
| Foreword | 3 |
| Warranty | 3 |
| Safety..... | 4 |
| Bolt Torque | 5 |
| Operation..... | 6 |
| Planter Adjustment..... | 7-8 |
| Installation Instructions | 9-11 |
| Part Identification | 12-19 |

FOREWORD

You've just joined an exclusive but rapidly growing club.

For our part, we want to welcome you to the group and thank you for buying a Yetter product.

We hope your new Yetter products will help you achieve both goals-increase your productivity and increase your efficiency so that you may generate more profit.

This operator's manual has been designed into four major sections: Foreword, Safety Precautions, Installation Instructions and Parts Breakdown.



This **SAFETY ALERT SYMBOL** indicates important safety messages in the manual. When you see this symbol, be alert to the possibility of **PERSONAL INJURY** and carefully read the message that follows.

The word **NOTE** is used to convey information that is out of context with the manual text. It contains special information such as specifications, techniques and reference information of a supplementary nature.

The word **IMPORTANT** is used in the text when immediate damage will occur to the machine due to improper technique or operation.

Important will apply to the same information as specified by note only of an immediate and urgent nature.

It is the responsibility of the user to read the operator's manual and comply with the safe and correct operating procedure and to lubricate and maintain the product according to the maintenance schedule in the operator's manual.

The user is responsible for inspecting his machine and for having parts repaired or replaced when continued use of the product would cause damage or excessive wear to the other parts.

It is the user's responsibility to deliver his machine to the Yetter dealer who sold him the product for service or replacement of defective parts, which are covered by the warranty policy.

If you are unable to understand or follow the instructions provided in this publication, consult your local Yetter dealer or contact:

YETTER MANUFACTURING CO.

309/776-4111

800/447-5777

309/776-3222 (FAX)

Website: www.yetterco.com

E-mail: info@yetterco.com

WARRANTY

Yetter Manufacturing warrants all products manufactured and sold by it against defects in material. This warranty being expressly limited to replacement at the factory of such parts or products as shall appear to be defective after inspection. This warranty does not obligate the Company to bear cost of labor in replacement of parts. It is the policy of the Company to make improvements without incurring obligations to add them to any unit already sold. No warranty is made or authorized to be made, other than herein set forth. This warranty is in effect for one year after purchase.

DEALER: _____

Yetter Manufacturing warrants its own products only and cannot be responsible for damages to equipment on which mounted.

BE ALERT!

YOUR SAFETY IS INVOLVED



WATCH FOR THIS SYMBOL. IT POINTS OUT IMPORTANT SAFETY PRECAUTIONS. IT MEANS “ATTENTION – BE ALERT!”

It is your responsibility as an owner, operator, or supervision to know and instruct everyone using this machine at the time of initial assignment and at least annually thereafter, of the proper operation, precautions, and work hazards which exist in the operation of the machine in accordance with OSHA regulations.

Safety Is No Accident

The following safety instructions, combined with common sense, will save your equipment from needless damage and the operator from unnecessary exposure to personal hazard. Pay special attention to the caution notes in the text. Review this manual at least once a year with all operators.



1. Read and understand the operator's manual before operating this machine. Failure to do so is considered a misuse of the equipment.
2. Make sure equipment is secure before operating.
3. Always keep children away from equipment when operating.
4. Make sure everyone that is not directly involved with the operation is out of the work area before beginning operation.
5. Make sure all safety devices, shields, and guards are in place and functional before beginning operation
6. Shut off all power to adjust, service, or clean.
7. Keep hands, feet, and clothing away from moving parts. It is a good idea to remove all jewelry before operating.
8. Inspect the machine periodically during operation for signs of excessive wear, loose fasteners, and unusual noises.

Lubricate all bearings and moving parts as assembled. Make certain that they work freely.



Warning: Never work around the toolbar/implement while in a raised position without using safety lockups.



Caution: The Titan™ Residue Manager and its attachments are very heavy. Pay extra attention to lifting techniques while handling or maneuvering the system during assembly. Failure to do so may lead to personal injury.

BOLT TORQUE



Important: Over-tightening hardware can cause just as much damage as under-tightening. Tightening hardware beyond the recommended range can reduce its shock load capacity.





All hardware on the Titan™ Residue Manager is Grade 5 or Grade 8, unless otherwise noted. Grade 5 cap screws are marked with three radial lines on the head. Grade 8 cap screws are marked with six radial lines on the head. If hardware must be replaced, be sure to replace it with hardware of equal size, strength and thread type. Refer to the torque values chart when tightening hardware.

The chart below is a guide for proper torque. Use it unless a specified torque is called out elsewhere in the manual.

Torque is the force applied to the end of the handle or cheater bar, times the length of the handle or bar.

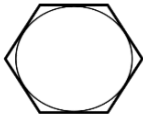
Use a torque wrench wherever possible.

The following table shows torque in ft-lbs for coarse thread hardware.

| Bolt Diameter and Threads per Inch |  Grade 2 |  Grade 5 |  A-325 |  Grade 8 |
|------------------------------------|--|--|---|--|
| 1/4 | 6 | 10 | | 14 |
| 5/16 | 12 | 20 | | 30 |
| 3/8 – 16 | 25 | 35 | | 50 |
| 7/16 – 14 | 35 | 55 | | 80 |
| 1/2 – 13 | 55 | 85 | | 125 |
| 9/16 – 12 | 75 | 125 | | 175 |
| 5/8 – 11 | 105 | 170 | | 235 |
| 3/4-10 | 185 | 305 | | 425 |
| 7/8 – 9 | 170 | 445 | | 690 |
| 1-8 | 260 | 670 | | 1030 |
| 1 1/8 – 7 | 365 | 900 | | 1460 |
| 1 1/4 - 7 | 515 | 1275 | | 2060 |
| 1 3/8 – 6 | 675 | 1675 | | 2700 |
| 1 1/2 - 6 | 900 | 2150 | | 3500 |
| 1 3/4 – 5 | 1410 | 3500 | | 5600 |

OPERATION



Where rocks are present, the residue manager should be set to float. The system can be damaged if a rigid setting is used.

Adjust the residue manager to move crop residue aside and not to move soil. Adjustments to the residue manager may have to be made with changing field conditions and the type and/or amount of residue. Use the handle for leverage when changing depth settings.

Float Settings

Install the adjustment pin below the combo arm.

To raise the wheels, lift the combo arm and move the adjustment pin up.

To lower the wheels, lift the combo arm and move the adjustment pin down.

Rigid Settings

Install the adjustment pin through the combo arm.

To raise wheels, lift the combo arm to the desired position and insert the pin.

To lower wheels, lower the combo arm to the desired position and insert the pin.

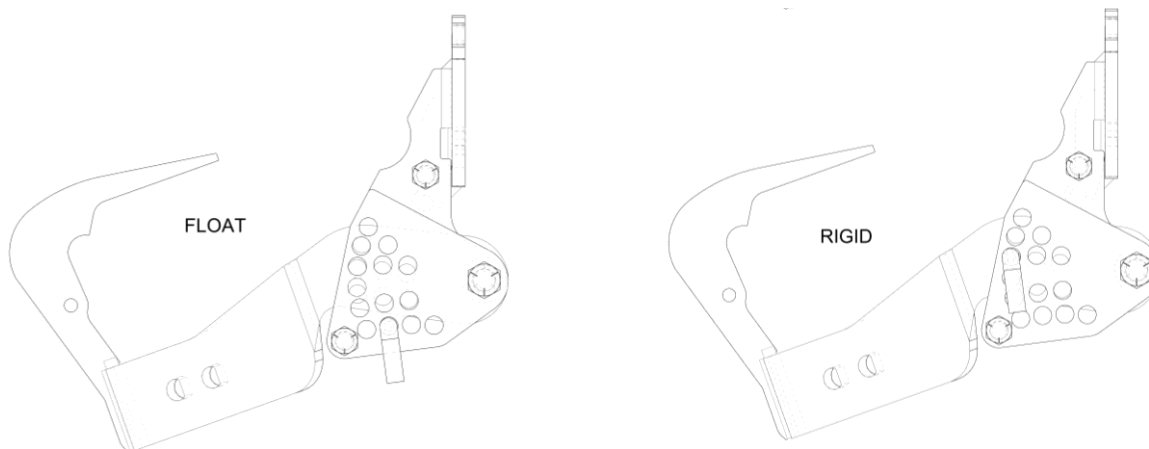

Residue Manger Do's and Don'ts

1. DO NOT move soil; Residue Managers are designed to move crop residue only.
2. DO NOT operate planter at slow speeds, ground speed affects how aggressive the spoke wheels are. Operate at sufficient speed (4-6 mph) to maintain good residue flow.
3. DO NOT expect 100% of crop residue to be cleared. It is not necessary and would necessitate engaging the soil. The width of the cleared path depends on ground conditions, depth setting, and ground speed.
4. DO expect to see wheels occasionally quit turning. This indicates ideal (shallow) setting which is not moving soil.
5. DO adjust toolbar frame height 20"-22" and drawbar to level correctly. This is very important to ensure planter opener will follow ground contours properly.

STOP

Read this before using the Yetter product.

IMPORTANT: failure to properly set the planter frame height and levelness can result in less than successful operation of the planter and the Yetter product and may result in damaged equipment. All operators should read and thoroughly understand the instructions given prior to using the Yetter product.

NOTE: **DO NOT** use this product if the planter is not adjusted properly!

Leveling the planter:

With the planter lowered to proper operating height (**Usually 20"-22"**). **Read the planter operator's manual for recommended setting.** Check to be sure the toolbar and row unit parallel arms are level fore and aft. **Re-check** when the planter is in the **field** and has been **fully loaded** with seed, fertilizer, granular chemicals, etc. Also, a field check with a bubble level on the frame should be made of the hitch height to ensure level operation front to back.

It is important for the planter to operate level laterally. Tire pressure must be maintained at pressures specified by the manufacturer.

Field and actual planting conditions change and will dictate planter frame heights. You must ensure that the row unit parallel arms are approximately parallel with the ground.

IMPORTANT: For proper operation of the planter attachments and row units, it is imperative that the planter toolbars and row unit parallel arms be level side-to-side and front-to-rear. The toolbar frame should operate at a 20"-22" height from the **planting surface**. Check the manufacturer's operator's manual for instructions on how to adjust the frame height and levelness.

PLANTER ADJUSTMENT

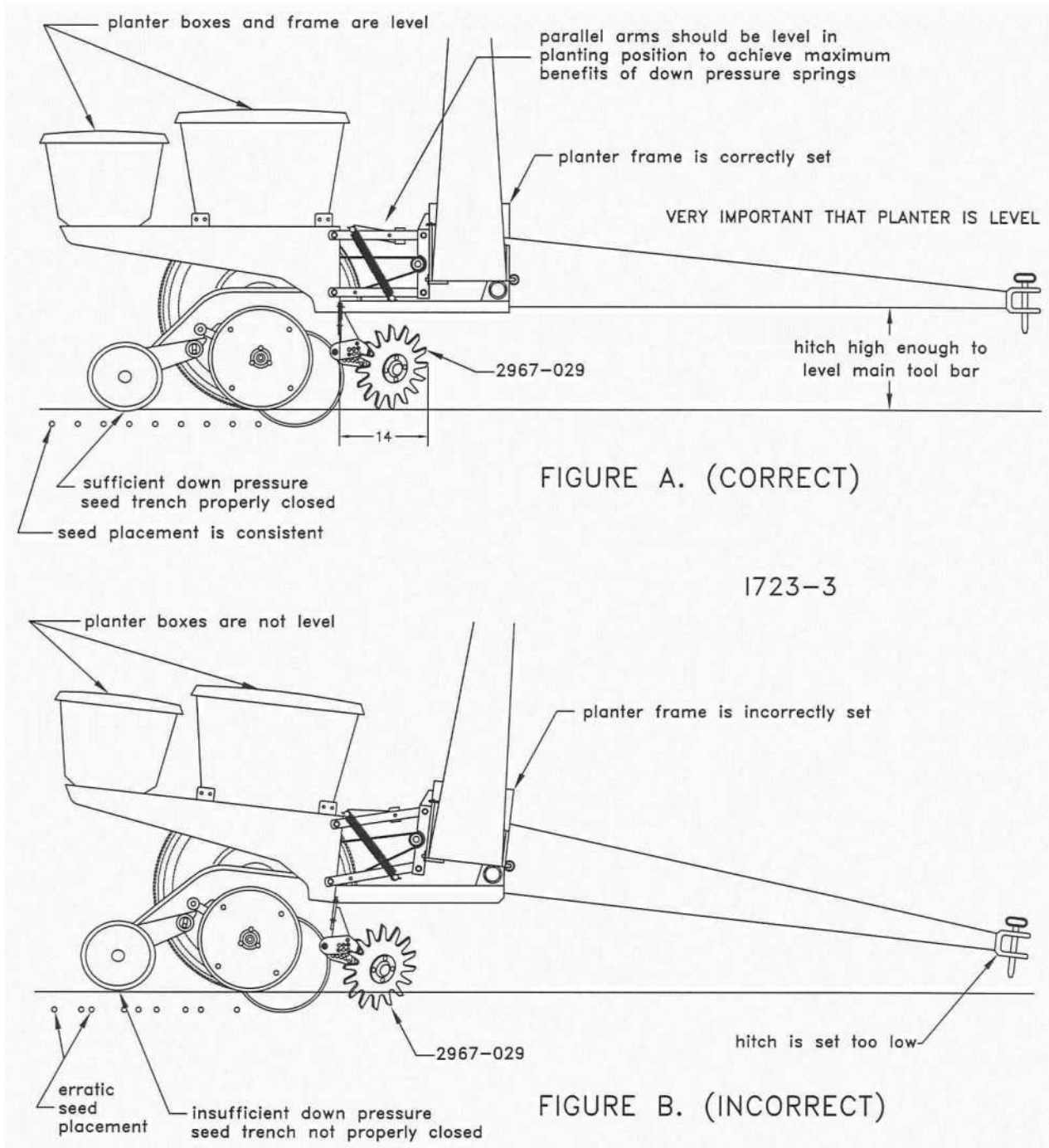

INSTALLATION INSTRUCTIONS

Step 1: Attach the 2966-290 mount bracket to the planter unit using (3) 1/2" bolts and lock nuts.

JD 7000, KINZE
WHITE 6000
YETTER

INSERT 1/2" X 1" BOLT THROUGH THE LOWER RIGHT HOLE IN ROW UNIT FROM REAR AND THREAD INTO THE MOUNT BRACKET

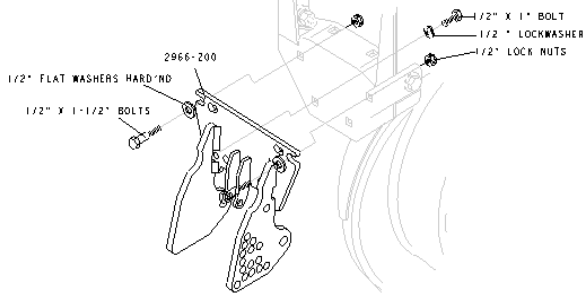

WHITE 8000

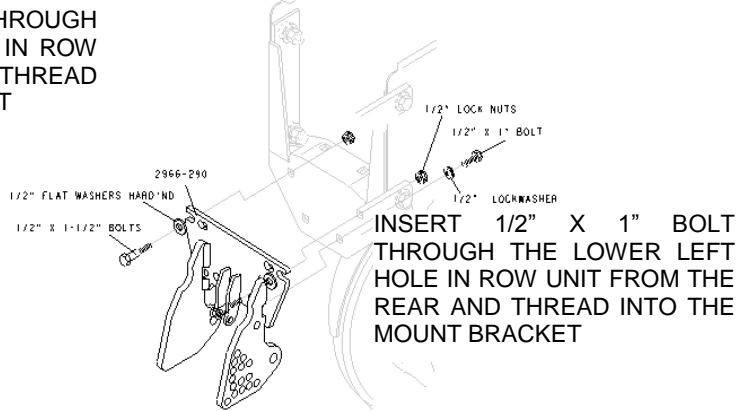

JD 1700, 7200 KINZE 4900

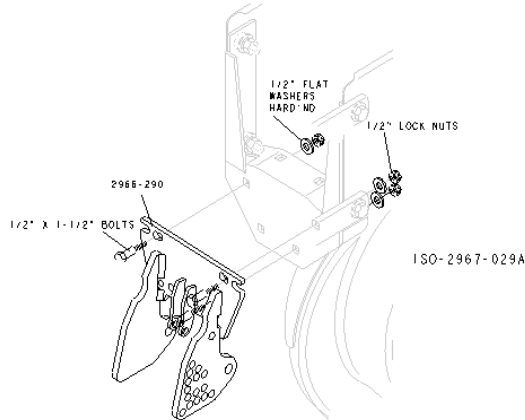

WHITE 9000

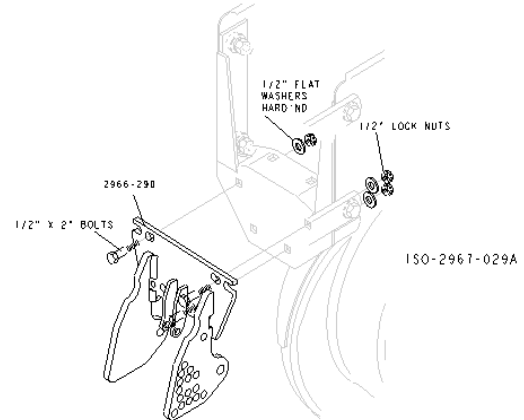

Step 1A: Attach the 2966-293 adapter to the CIH row unit using the 1/2" x 3-1/2" bolts and lock nuts. Then, install the 2966-290 mount bracket to the adapter using the 1/2" x 1-1/2" carriage bolts and flanged lock nuts.

INSTALLATION INSTRUCTIONS

Step 2: Choose the hole in which to attach the RM wheel assemblies. Attach the RM wheel/hub assemblies to the combo arm using 5/8" lock washers and hex nuts. If applicable, adjust the bearing shield to top dead center then, rotate slightly forward. Torque to 150 ft-lbs.

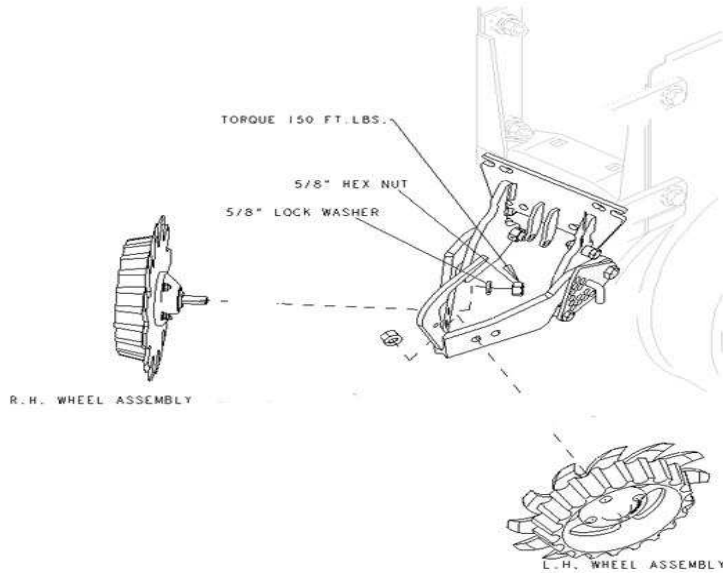

Step 3: ONLY FOR 2967-097A MOUNTING ON CNH RU

Attach the up-stop to the planter row unit parallel arms using the 3/8" hardware.

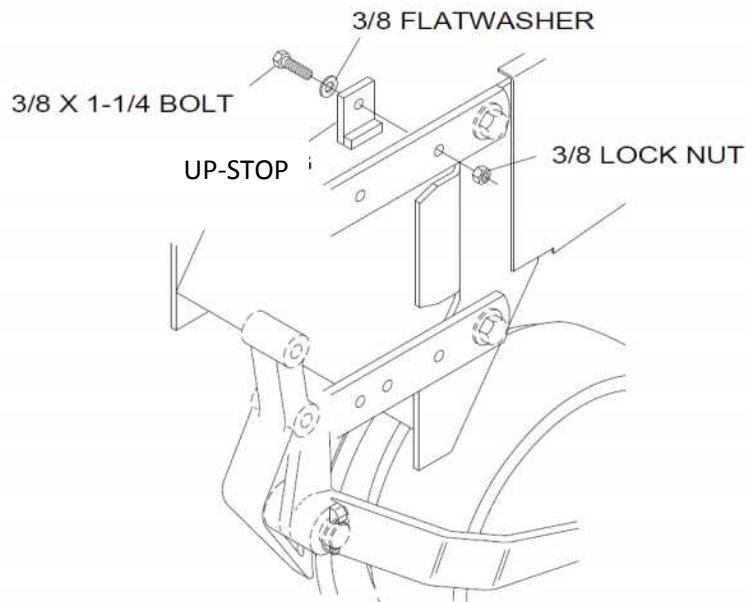

1727-4A

PART IDENTIFICATION

2967-029B

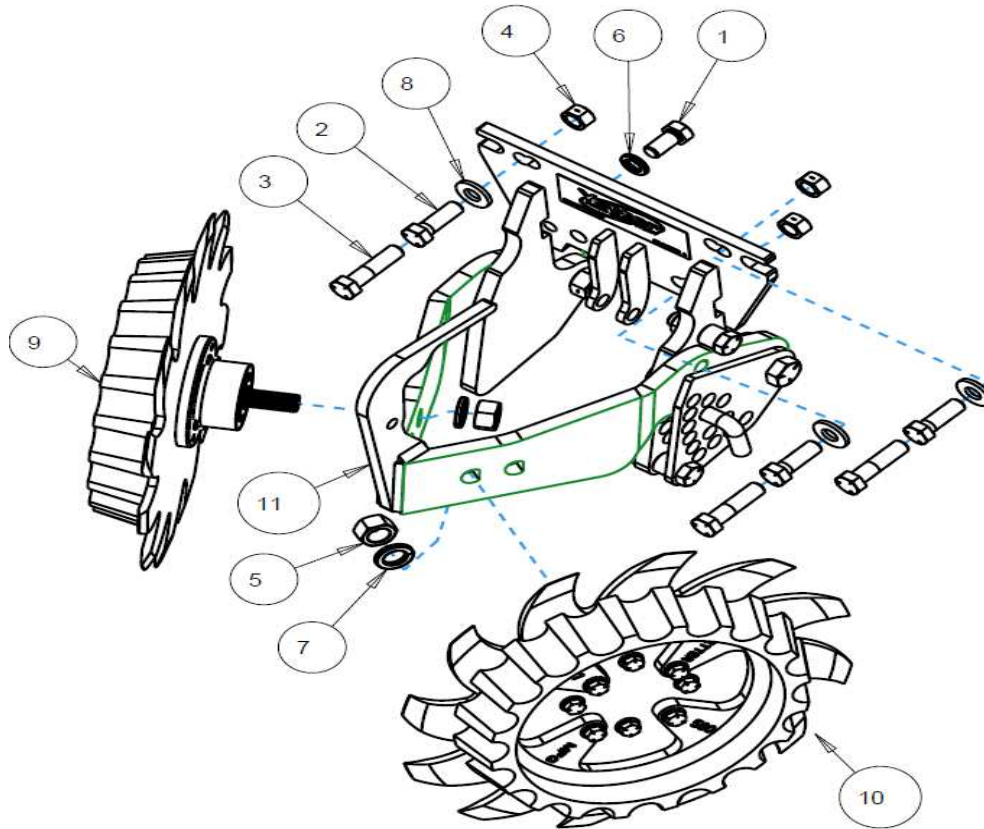

| ITEM | PART NO. | DESCRIPTION | QTY |
|------|-------------------|--------------------------------|-----|
| 1 | 2502-292 | 1/2-13 X 1 HHCS GR. 5 ZP | 1 |
| 2 | 2502-294 | 1/2-13 X 1-1/2 HHCS GR5 ZP | 3 |
| 3 | 2502-351 | 1/2-13 X 2 HHCS GR.5 ZP | 3 |
| 4 | 2520-357 | 1/2-13 LOCK HEX NUT, GR A, ZP | 4 |
| 5 | 2520-452 | 5/8-11 HEX NUT GR 8 ZP | 2 |
| 6 | 2525-352 | 1/2 MED LOCKWASHER ZP. | 1 |
| 7 | 2525-451 | 5/8 MED. LOCKWASHER ZP. | 2 |
| 8 | 2526-355 | 1/2 FLAT WASHER HARD'ND ZP | 3 |
| 9 | 2966-140-ST-FW | SHRKTH ASSY,RH,3"D-BOLT FLT WL | 1 |
| 10 | 2966-141-ST-FW | SHRKTH ASSY,LH,3"D-BOLT FLT WL | 1 |
| 11 | 2967-029A-SUBASSY | SHORT ARM R.M. SUBASSEMBLY | 1 |

PARTS IDENTIFICATION

2967-029A-SUBASSY

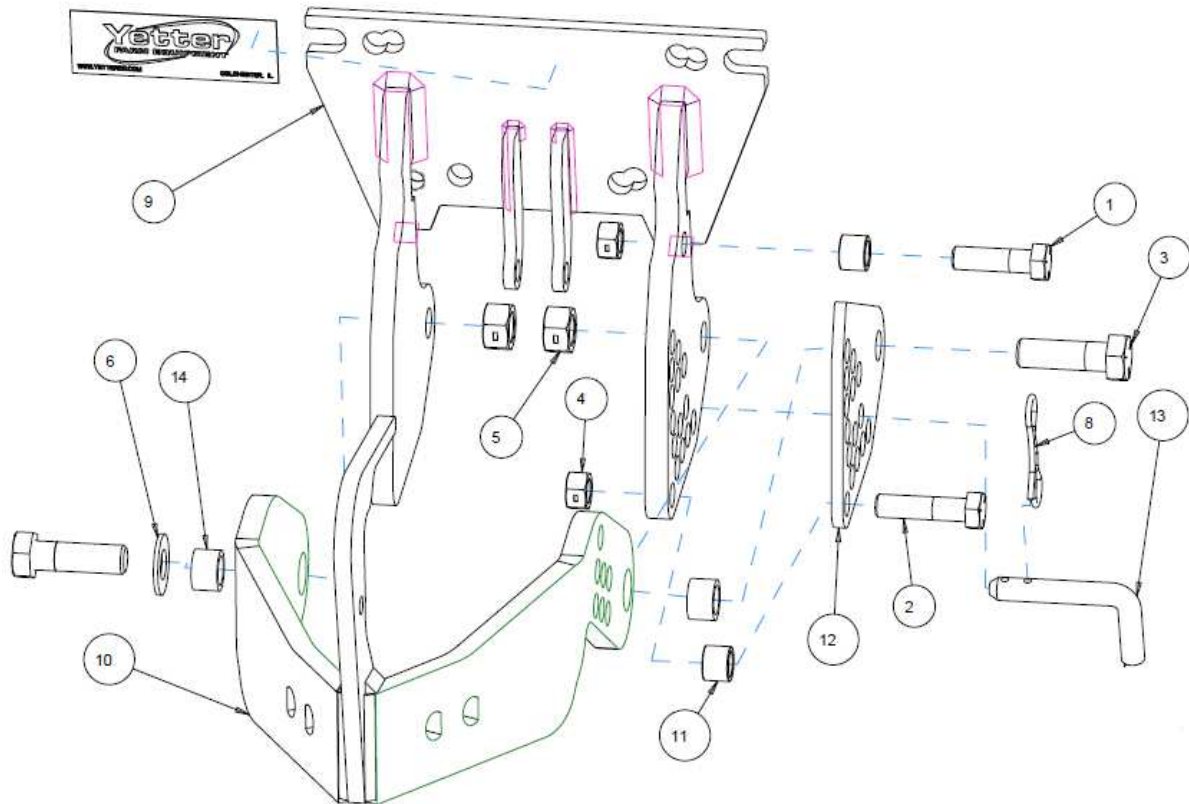

| ITEM | PART NO. | DESCRIPTION | QTY |
|------|----------|-------------------------------|-----|
| 1 | 2502-317 | 1/2-13 X 1-3/4 HHCS GR5 ZP | 1 |
| 2 | 2502-351 | 1/2-13 X 2 HHCS GR.5 ZP | 1 |
| 3 | 2502-391 | 5/8-11 X 2 HHCS GR 5 ZP | 2 |
| 4 | 2520-357 | 1/2-13 LOCK HEX NUT, GR A, ZP | 2 |
| 5 | 2520-459 | 5/8-11 LOCK HEX NUT, GR B, ZP | 2 |
| 6 | 2526-453 | 5/8 SAE FLATWASHER ZP | 1 |
| 7 | 2565-162 | YETTER DECAL | 1 |
| 8 | 2570-448 | .120 BOWTIE LOCKING COTTER ZP | 1 |
| 9 | 2966-290 | MOUNT, W, SHORT TITAN | 1 |
| 10 | 2966-292 | ARM, W, WIDE TITAN | 1 |
| 11 | 2967-622 | 9/16" SPACER ZP | 2 |
| 12 | 2967-639 | SECONDARY ADJUSTMENT PLATE | 1 |
| 13 | 2984-326 | R.M. UPSTOP PIN ZP | 1 |
| 14 | 6000-335 | 9/16" BUSHING | 2 |

PARTS IDENTIFICATION

2967-029B-BW-PP

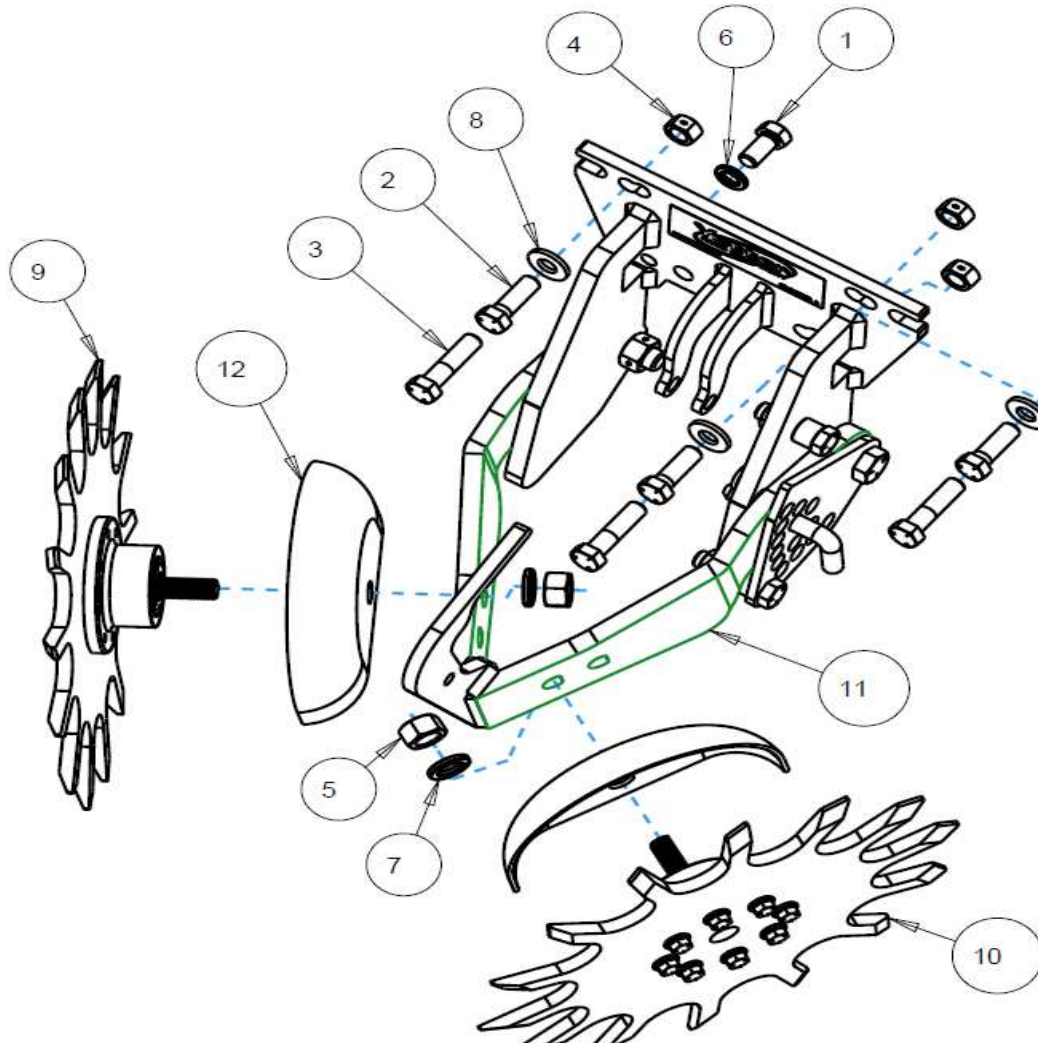

| ITEM | PART NO. | DESCRIPTION | QTY |
|------|----------------------|--------------------------------|-----|
| 1 | 2502-292 | 1/2-13 X 1 HHCS GR. 5 ZP | 1 |
| 2 | 2502-294 | 1/2-13 X 1-1/2 HHCS GR5 ZP | 3 |
| 3 | 2502-351 | 1/2-13 X 2 HHCS GR.5 ZP | 3 |
| 4 | 2520-357 | 1/2-13 LOCK HEX NUT, GR A, ZP | 4 |
| 5 | 2520-452 | 5/8-11 HEX NUT GR 8 ZP | 2 |
| 6 | 2525-352 | 1/2 MED LOCKWASHER ZP. | 1 |
| 7 | 2525-451 | 5/8 MED. LOCKWASHER ZP. | 2 |
| 8 | 2526-355 | 1/2 FLAT WASHER HARD'ND ZP | 3 |
| 9 | 2966-140-BW | BEVEL WHEEL ASSY, RH, 3"D-BOLT | 1 |
| 10 | 2966-141-BW | BEVEL WHEEL ASSY,LH,3" D-BOLT | 1 |
| 11 | 2967-029A-SUBASSY-PP | SHORT ARM R.M. SUBASSEMBLY-PP | 1 |
| 12 | 2967-392 | SHIELD, RM-PAINTED | 2 |

PART IDENTIFICATION

2967-029A

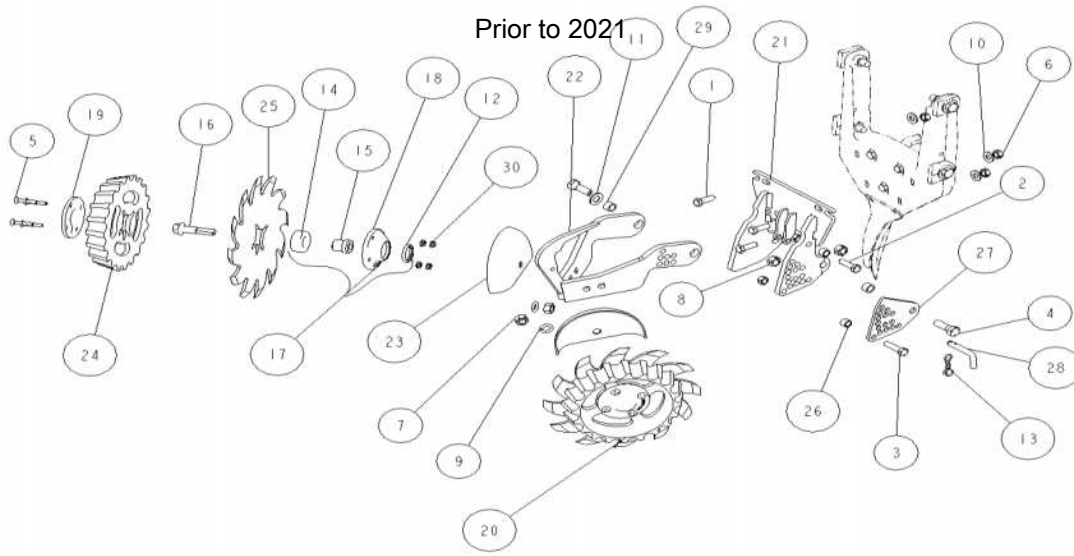

| ITEM | PART # | DESCRIPTION | QTY |
|------|----------------|--|-----|
| 1 | 2502-294 | 1/2 -13 X 1-1/2 HHCS GRADE 5 | 3 |
| | 2502-351 | 1/2 -13 X 2 HHCS GRADE 5 (WHITE 9000) | 3 |
| 2 | 2502-317 | 1/2 -13 X 1-3/4 HHCS GRADE 5 | 1 |
| 3 | 2502-351 | 1/2 -13 X 2 HHCS GRADE 5 | 1 |
| 4 | 2502-391 | 5/8 -11 X 2 HHCS GRADE 5 | 2 |
| 5 | 2505-209 | 5/16 -18 X 1-3/4 CARRIAGE BOLT GRADE 5 (FLOATER) | 8 |
| | 2505-207 | 5/16 -18 X 1-1/4 CARRIAGE BOLT GRADE 5 (SHARK) | 8 |
| | 2505-208 | 5/16 -18 X 1-1/2 CARRIAGE BOLT GRADE 5 (BEVELED) | 8 |
| 6 | 2520-357 | 1/2 -13 LOCK HEX NUT | 5 |
| 7 | 2520-452 | 5/8 -11 HEX NUT | 2 |
| 8 | 2520-459 | 5/8 -11 LOCK HEX NUT | 2 |
| 9 | 2525-451 | 5/8 LOCK WASHER | 2 |
| 10 | 2526-355 | 1/2 FLAT WASHER HARDENED | 3 |
| 11 | 2526-453 | 5/8 SAE FLAT WASHER | 1 |
| 12 | 2550-069 | SEAL | 2 |
| 13 | 2570-448 | HAIRPIN COTTER | 1 |
| 14 | 2570-594 | BEARING | 2 |
| 15 | 2570-715 | INSERT | 2 |
| 16 | 2570-740 | D-BOLT 5/8 -11 X 2.812 GRADE 8 | 2 |
| 17 | 2965-128 | HUB AND BEARING ASSEMBLY | 2 |
| 18 | 2965-351 | HUB | 2 |
| 19 | 2965-352 | CAP | 2 |
| 20 | 2966-141-ST-FW | SHARK WHEEL ASSEMBLY LH FLOATER (SHOWN) | 1 |
| | 2966-140-ST-FW | SHARK WHEEL ASSEMBLY RH FLOATER | 1 |
| 21 | 2966-290 | MOUNT BRACKET | 1 |
| 22 | 2966-292 | ARM WIDE | 1 |
| 23 | 2967-392 | SHIELD | 2 |
| 24 | 2967-555 | FLOATER WHEEL (OPTION) | 2 |
| 25 | 2967-602 | 13" SHARK WHEEL (SHOWN) | 2 |
| | 2967-404 | 13" TAPER TOOTH (OPTION) | 2 |
| | 6200-350 | 13" BEVELED WHEEL LH (OPTION) | 1 |
| | 6200-351 | 13" BEVELED WHEEL RH (OPTION) | 1 |
| 26 | 2967-622 | 9/16" SPACER | 2 |
| 27 | 2967-639 | ADJUSTMENT PLATE | 1 |
| 28 | 2984-326 | PIN | 1 |
| 29 | 6000-335 | 9/16" BUSHING | 2 |
| 30 | 2520-206 | 5/16 -18 SERRATED FLANGE HEX NUT | 8 |

PARTS IDENTIFICATION

2967-029A-SUBASSY-PP

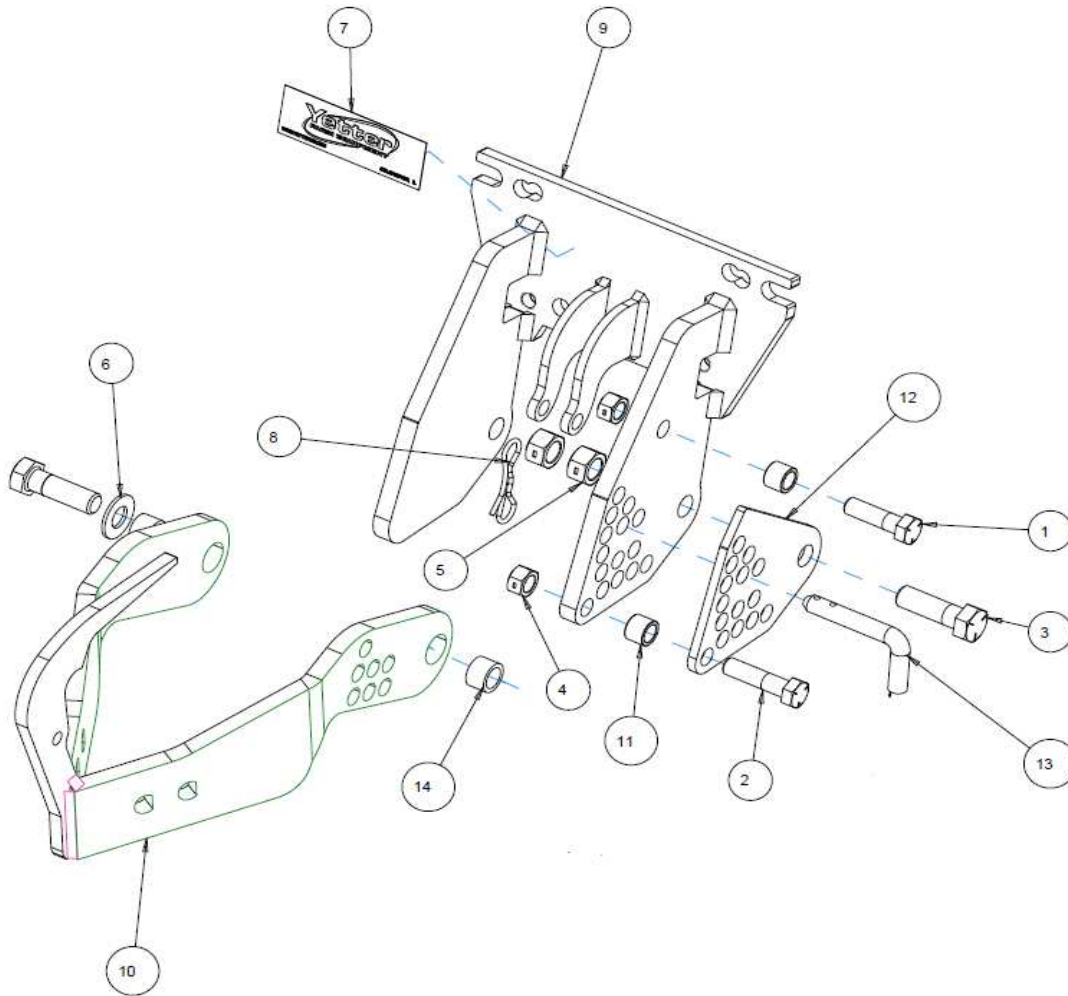

| ITEM | PART NO. | DESCRIPTION | QTY |
|------|-----------|-------------------------------|-----|
| 1 | 2502-317 | 1/2-13 X 1-3/4 HHCS GR5 ZP | 1 |
| 2 | 2502-351 | 1/2-13 X 2 HHCS GR.5 ZP | 1 |
| 3 | 2502-391 | 5/8-11 X 2 HHCS GR 5 ZP | 2 |
| 4 | 2520-357 | 1/2-13 LOCK HEX NUT, GR A, ZP | 2 |
| 5 | 2520-459 | 5/8-11 LOCK HEX NUT, GR B, ZP | 2 |
| 6 | 2526-453 | 5/8 SAE FLATWASHER ZP | 1 |
| 7 | 2565-162 | YETTER DECAL | 1 |
| 8 | 2570-448 | .120BOWTIE LCKING COTT ZP | 1 |
| 9 | 2966-2002 | MOUNT WA, W, SHORT TITAN, PP | 1 |
| 10 | 2966-292 | ARM, W, WIDE TITAN | 1 |
| 11 | 2967-622 | 9/16" SPACER ZP | 2 |
| 12 | 2967-639 | SECONDARY ADJUSTMENT PLATE | 1 |
| 13 | 2984-326 | R.M. UPSTOP PIN ZP | 1 |
| 14 | 6000-335 | 9/16" BUSHING | 2 |

PARTS IDENTIFICATION

2967-097B-ST

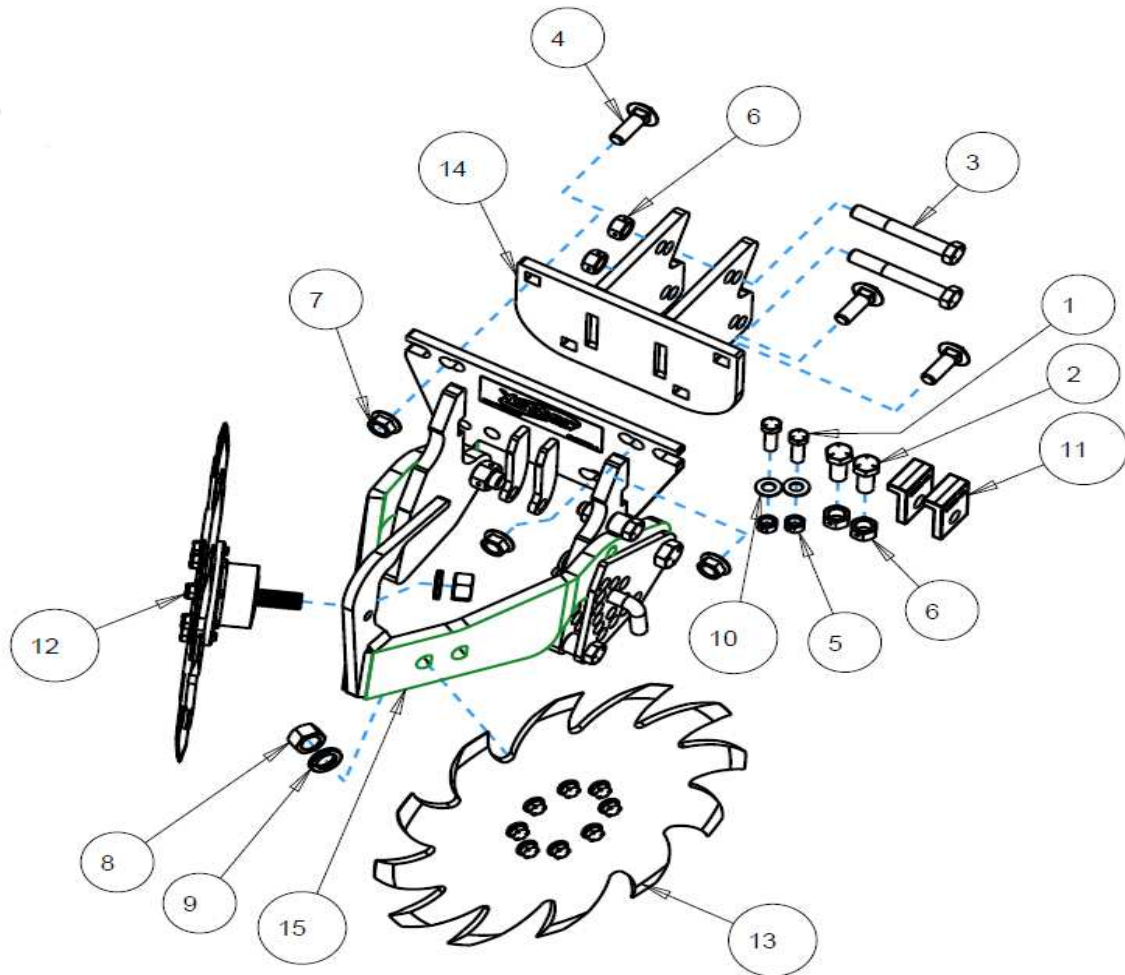

| ITEM | PART NO. | DESCRIPTION | QTY |
|------|-------------------|-------------------------------------|-----|
| 1 | 2502-244 | 3/8-16 X 1-1/4 HHCS GR 5 ZP | 2 |
| 2 | 2502-293 | 1/2-13 X 1-1/4 HHCS GR5 ZP | 2 |
| 3 | 2502-316 | 1/2-13 X 3-1/2 HHCS GR5 ZP | 2 |
| 4 | 2505-339 | 1/2-13 X 1-1/2 CARBLT G5ZP | 3 |
| 5 | 2520-255 | 3/8-16 LOCK HEX NUT, GR A, ZP | 2 |
| 6 | 2520-357 | 1/2-13 LOCK HEX NUT, GR A, ZP | 4 |
| 7 | 2520-361 | 1/2-13 FLANGE WHZLCK HXNT, GR 5, ZP | 3 |
| 8 | 2520-452 | 5/8-11 HEX NUT GR 8 ZP | 2 |
| 9 | 2525-451 | 5/8 MED. LOCKWASHER ZP. | 2 |
| 10 | 2526-253 | 3/8 SAE FLATWASHER ZP | 2 |
| 11 | 2960-411 | CYCLO STOP CASTING, LARGE HOLE | 2 |
| 12 | 2966-140-ST | SHARKTOOTH ASSY,RH,3" D-BOLT | 1 |
| 13 | 2966-141-ST | SHARKTOOTH ASSY,LH,3" D-BOLT | 1 |
| 14 | 2966-293 | ADAPTER, W, TILLAGE ATTACHED | 1 |
| 15 | 2967-029A-SUBASSY | SHORT ARM R.M. SUBASSEMBLY | 1 |

PARTS IDENTIFICATION

2965-135 UP-STOP KIT

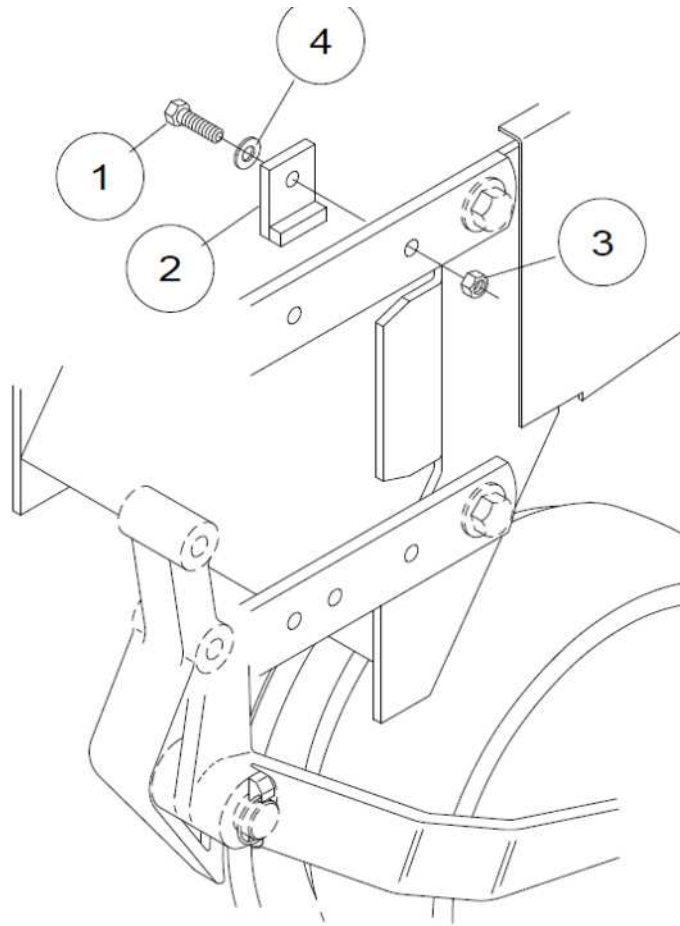

| ITEM | PART # | DESCRIPTION | QTY |
|------|----------|--------------------------|-----|
| 1 | 2502-244 | 3/8-16 x 1-1/4 HHCS GR 5 | 2 |
| 2 | 2960-223 | UP-STOP | 2 |
| 3 | 2520-255 | 3/8-16 HEX LOCK NUT | 2 |
| 4 | 2526-253 | 3/8 SAE FLATWASHER | 2 |

PARTS IDENTIFICATION
2966-140-ST-FW
RIGHT HAND SHARK TOOTH WHEEL ASSEMBLY

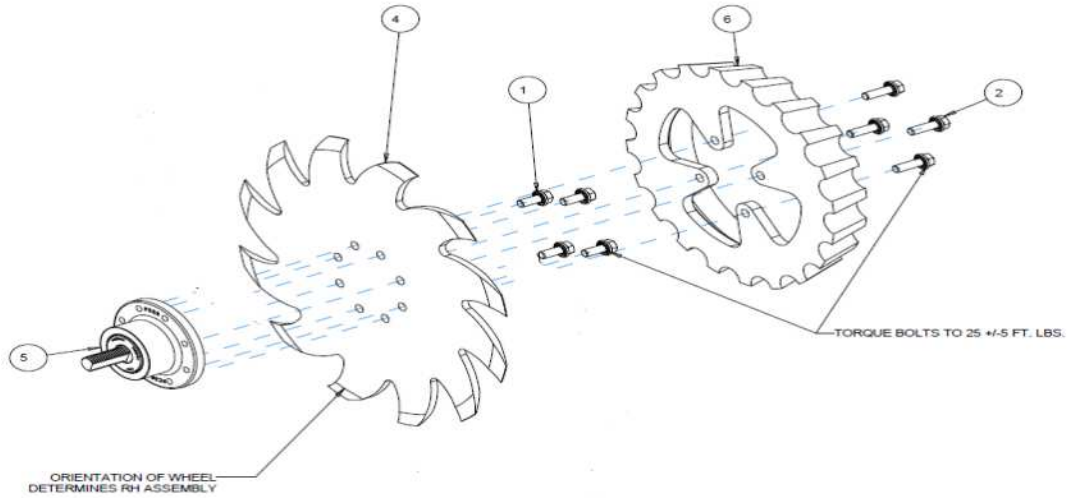

| ITEM | PART NO. | DESCRIPTION | QTY |
|------|----------|-----------------------------|-----|
| 1 | 2502-220 | 5/16-18 X 3/4 HHFS GR5 ZP | 4 |
| 2 | 2502-221 | 5/16-18 X 1 HHFS GR5 ZP | 4 |
| 3 | 2515-562 | 13" WHEEL COVER, BLACK | 2 |
| 4 | 2571-286 | SHARKTOOTH WHEEL, 8 BOLT | 1 |
| 5 | 2965-500 | HUB ASSEMBLY, 1.406 SPINDLE | 1 |
| 6 | 2967-560 | FLOATER WHEEL | 1 |

PARTS IDENTIFICATION
2966-140-BW-FW
RIGHT HAND BEVEL WHEEL ASSEMBLY

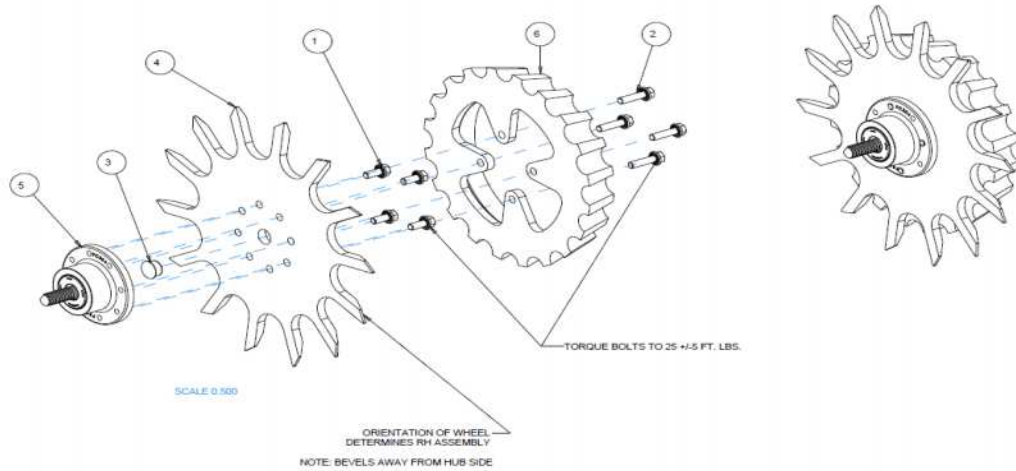

| ITEM | PART NO. | DESCRIPTION | QTY |
|------|------------|------------------------------|-----|
| 1 | 2502-220 | 5/16-18 X 3/4 HHFS GR5 ZP | 4 |
| 2 | 2502-222 | 5/16-18 X 1-1/4 HHFS GR5 ZP | 4 |
| 3 | 2570-994 | BEVEL WHEEL CENTER HOLE PLUG | 1 |
| 4 | 2571-287-R | 13" BEVEL WHEEL, 8 BOLT, RH | 1 |
| 5 | 2965-500 | HUB ASSEMBLY, 1.406 SPINDLE | 1 |
| 6 | 2967-560 | FLOATER WHEEL | 1 |

PARTS IDENTIFICATION

2966-141-FW

LEFT HAND SPOKE WHEEL ASSEMBLY

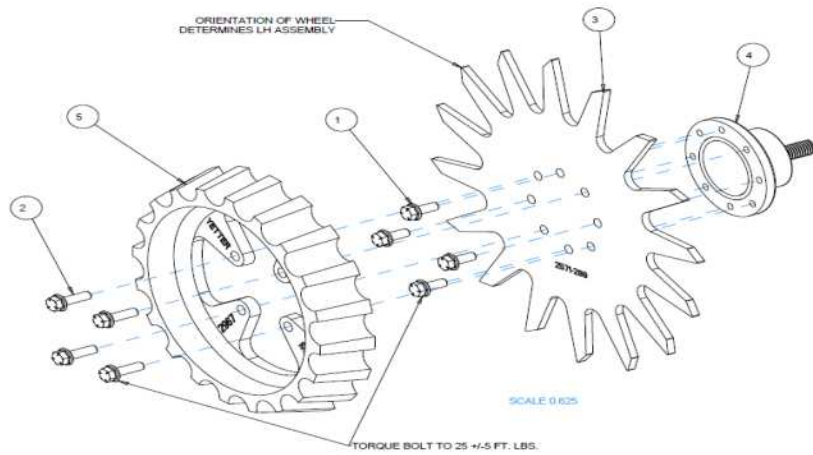

| ITEM | PART NO. | DESCRIPTION | QTY |
|------|----------|-------------------------------------|-----|
| 1 | 2502-220 | 5/16-18 X 3/4 HHFS GR5 ZP | 4 |
| 2 | 2502-221 | 5/16-18 X 1 HHFS GR5 ZP | 4 |
| 3 | 2571-289 | 13" TAPER TOOTH SPOKE WHEEL, 8 BOLT | 1 |
| 4 | 2965-500 | HUB ASSEMBLY, 1.406 SPINDLE | 1 |
| 5 | 2967-560 | FLOATER WHEEL | 1 |

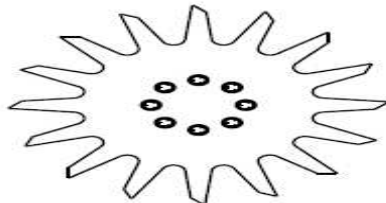

SPOKE WHEEL ASSEMBLY
RIGHT HAND 2966-140(SHOWN)
LEFT HAND 2966-141



SPOKE WHEEL ASSEMBLY W/FLOATER WHEEL
RIGHT HAND 2966-140-FW(SHOWN)
LEFT HAND 2966-141-FW

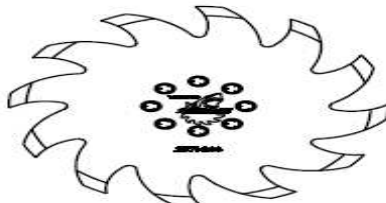

SHARKTOOTH WHEEL ASSEMBLY
RIGHT HAND 2966-140-ST(SHOWN)
LEFT HAND 2966-141-ST



SHARKTOOTH WHEEL ASSEMBLY W/FLOATER WHEEL
RIGHT HAND 2966-140-ST-FW(SHOWN)
LEFT HAND 2966-141-ST-FW

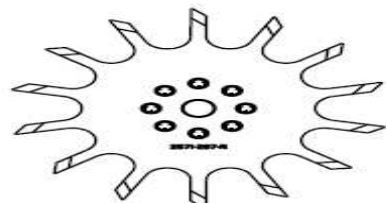

BEVEL WHEEL ASSEMBLY
RIGHT HAND 2966-140-BW(SHOWN)
LEFT HAND 2966-141-BW



BEVEL WHEEL ASSEMBLY W/FLOATER WHEEL
RIGHT HAND 2966-140-BW-FW(SHOWN)
LEFT HAND 2966-141-BW-FW

NOTES



A Tradition of Solutions since 1930

Yetter Farm Equipment Co

PO BOX 358 109 S. McDonough

Colchester, IL 62326-0358

Phone: 309-776-4111

Toll Free: 800-447-5777

Email: info@yetterco.com

For updated models and manuals visit the Yetter website:

www.yetterco.com

© Yetter Farm Equipment Co. All Rights Reserved

2565-696_Rev_K – 07/2021