



**TITAN™
RESIDUE MANAGER
FOR
CNH PLANTER UNITS
2967-008A
OPERATOR'S MANUAL
PART IDENTIFICATION
2565-695_REV_P • 06/2026**

YETTER MANUFACTURING CO.
FOUNDED 1930

Colchester, IL 62326-0358
Toll free: 800/447-5777
309/776-3222 (Fax)
Website: www.yetterco.com
E-mail: info@yetterco.com

YETTER

FOREWORD

You've just joined an exclusive but rapidly growing club.

For our part, we want to welcome you to the group and thank you for buying a Yetter product.

We hope your new Yetter products will help you achieve both goals-increase your productivity and increase your efficiency so that you may generate more profit.

This operator's manual has been designed into four major sections: Foreword, Safety Precautions, Installation Instructions and Parts Breakdown.

This **SAFETY ALERT SYMBOL** indicates important safety messages in the manual. When you see this symbol, be alert to the possibility of **PERSONAL INJURY** and carefully read the message that follows.

 **DANGER:** Indicates an imminently hazardous situation which, if not avoided "will" result in death or serious injury. This signal word is to be limited to the most extreme situations

 **WARNING:** Indicates a potentially hazardous situation which, if not avoided, "could" result in death or serious injury.

 **CAUTION:** Indicates a potentially hazardous situation, which if not avoided, "may" result in minor or moderate injury. It may also be used to alert against unsafe practices.

 **NOTICE:** Indicates information considered important, but not hazard related (e.g., messages relating to property damage).

It is the responsibility of the user to read the operator's manual and comply with the safe and correct operating procedure and to lubricate and maintain the product according to the maintenance schedule in the operator's manual.

The user is responsible for inspecting his machine and for having parts repaired or replaced when continued use of the product would cause damage or excessive wear to the other parts.

It is the user's responsibility to deliver his machine to the Yetter dealer who sold him the product for service or replacement of defective parts, which are covered by the warranty policy.

If you are unable to understand or follow the instructions provided in this publication, consult your local Yetter dealer or contact:

YETTER MANUFACTURING CO.

309/776-4111

800/447-5777

309/776-3222 (FAX)

Website: www.yetterco.com

E-mail: info@yetterco.com

WARRANTY

Yetter Manufacturing warrants all products manufactured and sold by it against defects in material. This warranty being expressly limited to replacement at the factory of such parts or products as shall appear to be defective after inspection. This warranty does not obligate the Company to bear cost of labor in replacement of parts. It is the policy of the Company to make improvements without incurring obligations to add them to any unit already sold. No warranty is made or authorized to be made, other than herein set forth. This warranty is in effect for one year after purchase.

DEALER: _____

Yetter Manufacturing warrants its own products only and cannot be responsible for damages to equipment on which mounted.



SAFETY PRECAUTIONS



A brief description of signal words that may be used in this manual:

DANGER: Indicates an imminently hazardous situation which, if not avoided “will” result in death or serious injury. This signal word is to be limited to the most extreme situations.

WARNING: Indicates a potentially hazardous situation which, if not avoided, “could” result in death or serious injury.

CAUTION: Indicates a potentially hazardous situation, which if not avoided, “may” result in minor or moderate injury. It may also be used to alert against unsafe practices.

NOTICE: Indicates information considered important, but not hazard related (e.g., messages relating to property damage).

Consult your implement and tractor operator’s manual for correct and safe operating practices. Be aware of towed implement width and allow safe clearance.

Safety decals are placed on the implement to alert the operator and others to the risk of personal injury or unsafe operation during normal operations and servicing.

1. The safety decals must be kept clean and in good condition to ensure that they are legible.
2. Safety decals must be replaced if they are missing or illegible.
3. When components are replaced during repair or servicing, check that the new components include the necessary safety signs.
4. Replacement safety decals may be obtained from your local dealer.



WARNING

Read these instructions carefully to acquaint yourself with the Equipment. Working with unfamiliar equipment can lead to accidents.

Never park the equipment on a steep incline or leave the equipment running unattended.

Never clean, lubricate or adjust a machine that is in motion.

Always check that straps are secure.

Make sure latches are in pinned position when moving equipment.

Do not allow children to operate this equipment.

Do not allow riders on the equipment, trailer and/or pick-up.

Use speed and caution dictated by the terrain being traversed. Do not operate on any slope steep enough to cause tipping or loss of control.

Read and understand the operator’s manual and require all other persons who will operate the equipment to do the same.

If operating on public roadways, where legal, be certain all lighting is operating properly and observe all traffic laws.

Beware of increased stopping distances and control effort when operating with implements attached.

Be familiar with all controls and be prepared to stop equipment quickly in an emergency.

FAILURE TO HEED MAY RESULT IN PERSONAL INJURY OR DEATH.

TABLE OF CONTENTS

Introduction.....pg.2
 Warranty.....pg.2
 Safety Information.....pg.2-3
 Table of Contents.....pg.4
 Bolt Torque.....pg.4
 Use Guide/Troubleshooting.....pg.5-6

Installation Instruction.....pg.7-9
 Operation.....pg.10

Parts Identification.....pg.11-15

BOLT TORQUE

Mounting bolts and hardware

Before operating the Titan™ Residue Manager for the first time, check to be sure that all hardware is tight. Check all hardware again after approximately 50 hours of operation and at the beginning of each planting season.

All hardware used on the Titan™ Residue Manager is Grade 5 unless otherwise noted. Grade 5 cap screws are marked with three radial lines on the head. If hardware must be replaced, be sure to replace it with hardware of equal size, strength and thread type. Refer to the torque values chart when tightening hardware.







NOTICE: Over tightening hardware can cause as much damage as when under tightening. Tightening hardware beyond the recommended range can reduce its shock load capacity.

The chart below is a guide for proper torque. Use it unless a specified torque is called out elsewhere in the manual.

Torque is the force you apply to the wrench handle or the cheater bar, times the length of the handle or bar.

Use a torque wrench whenever possible.

The following table shows torque in ft lbs for coarse thread hardware

BOLT DIA. AND THREADS PER INCH	 GRADE 2	 OR  GRADE 5 A-325	 GRADE 8
1/4	6	10	14
5/16	12	20	30
3/8 – 16	25	35	50
7/16 – 14	35	55	80
1/2 – 13	55	85	125
9/16 – 12	75	125	175
5/8 – 11	105	170	235
3/4 - 10	185	305	425
7/8 – 9	170	445	690
1-8	260	670	1030
1 1/8 – 7	365	900	1460
1 1/4 - 7	515	1275	2060
1 3/8 – 6	675	1675	2700
1 1/2 - 6	900	2150	3500
1 3/4 – 5	1410	3500	5600



Lubricate all bearings and moving parts as assembled and make certain that they work freely.

WARNING: Never work around the toolbar/implement while in a raised position without using safety lockups.



CAUTION: The Residue manager attachments are very heavy. Pay extra attention to lifting techniques while handling and or maneuvering the opener during assembly. Failure to do so may lead to personal injury.

OPERATION GUIDE/TROUBLESHOOTING



NOTICE: Please check the amount of travel that the planter row unit has before going to the field to plant.

NOTE: The recommended height of a level planter toolbar frame is 20"-22". Always visually check seed spacing and depth-calibrate your equipment if necessary.

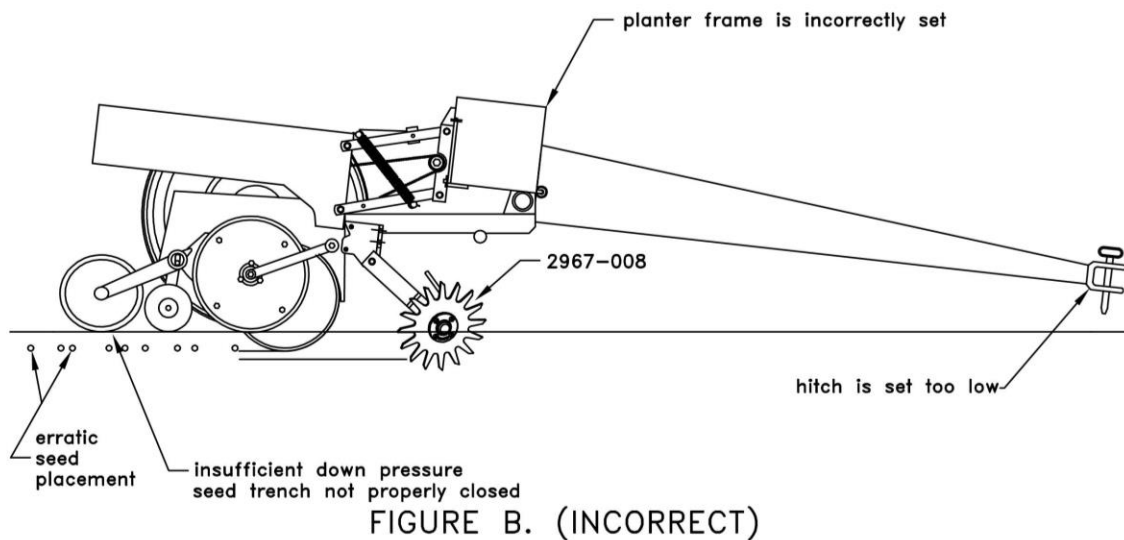
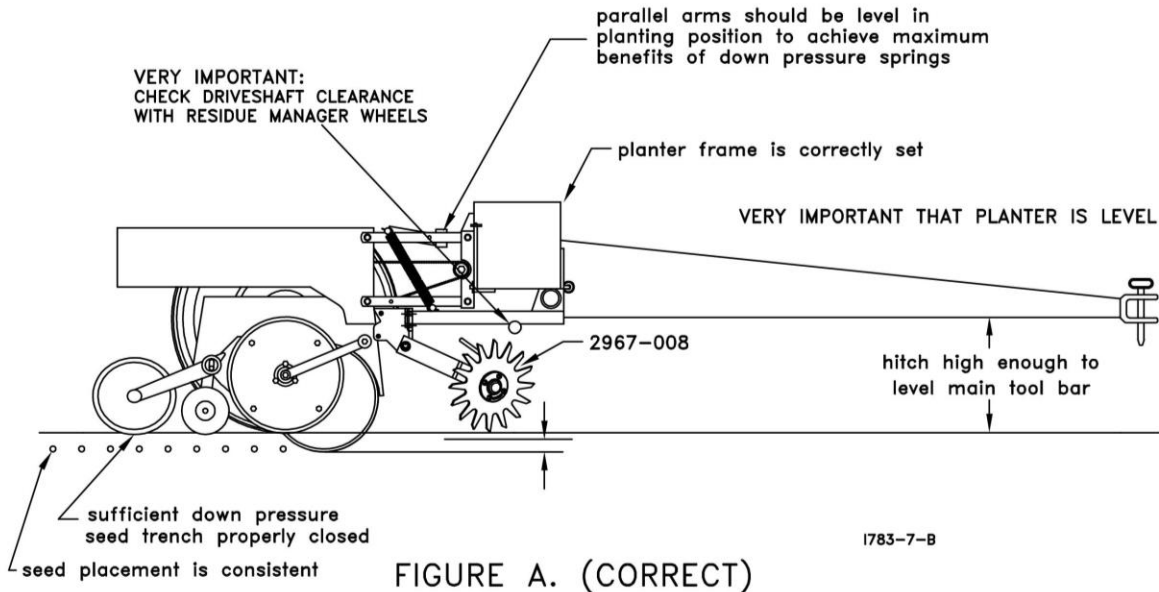

Figure A. – The planter hitch and frame are both 20" off the ground. To ensure this, visually check to see that the planter boxes are level and that the planter unit parallel arms are also parallel with the ground. **When using planter attachments located in front of the planter unit, this setting is very important.**

Figure B. – The planter hitch is set too low while the planter frame remains at 20" off the ground! Notice from the illustration that the unit mounted coulters is running deeper in the ground than the planter unit. This condition can result in the formation of an air pocket below the seedbed, which will in turn dramatically decrease seed growth.

NOTE: Both illustrations are strictly for reference only. They are intended to show that proper adjustment of the hitch height is critical. Consult your planter operator's manual for the proper height adjustment of the hitch.

OPERATION GUIDE/TROUBLESHOOTING



NOTICE: Please check the amount of travel that the planter row unit has before going to the field to plant.



NOTICE: Check the drive shaft clearance with the residue manager wheels. If the residue manager wheels can make contact with the drive shaft, the drive shaft could be damaged.

RESIDUE WHEEL MOUNTED
IN THE FORWARD HOLE

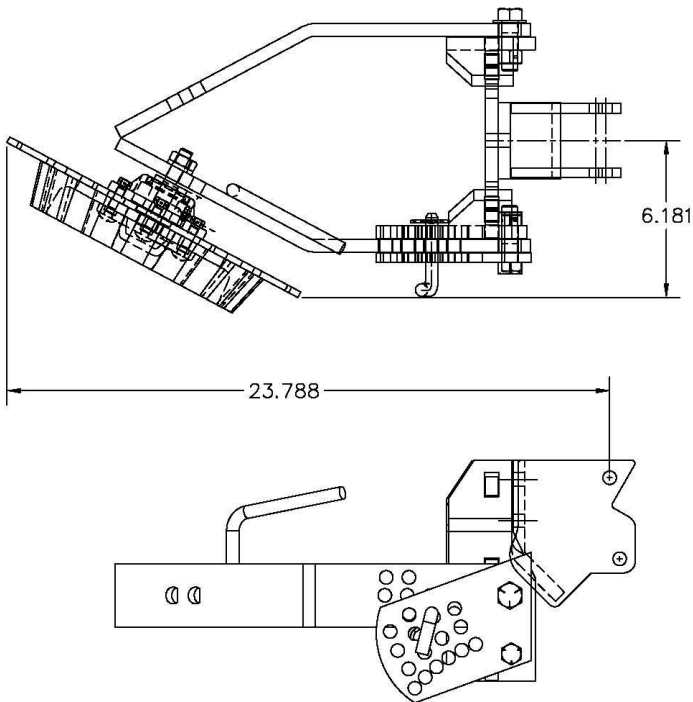

RESIDUE WHEEL MOUNTED
IN THE REAR HOLE

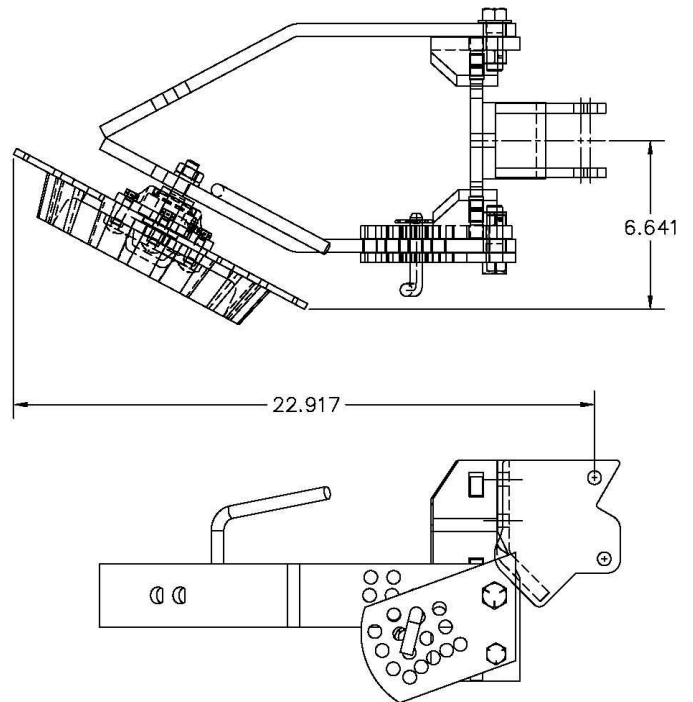

1783-10

INSTALLATION INSTRUCTIONS

2967-008 - TITAN™ RESIDUE MANAGER WITH A 2960 COULTER

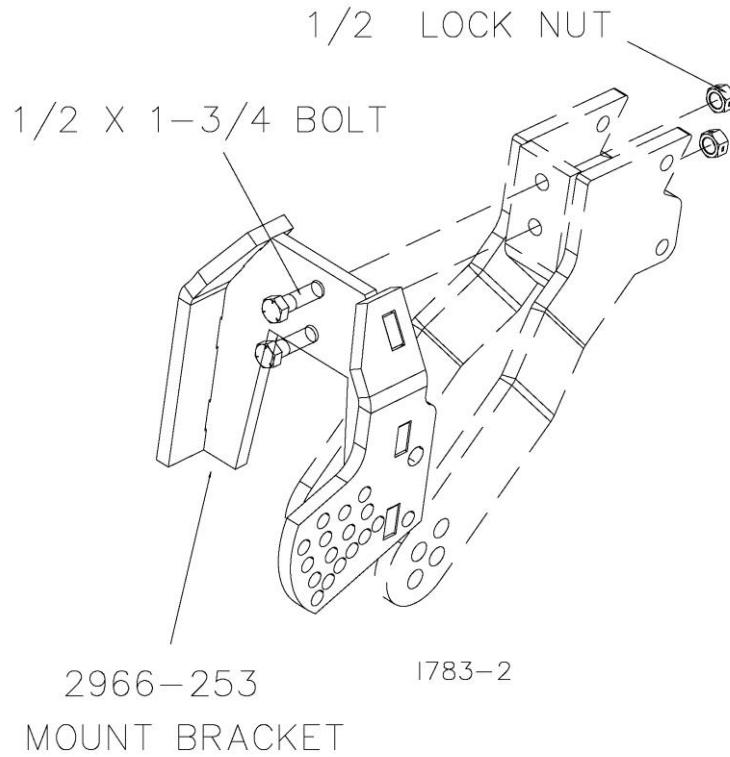

*** BLADE REMOVED FOR CLARITY**

STEP 1. Attach the 2966-253 mount bracket to the coulter bracket using 2) 1/2" x 1-3/4" bolt and 1/2" lock nuts.

INSTALLATION INSTRUCTIONS

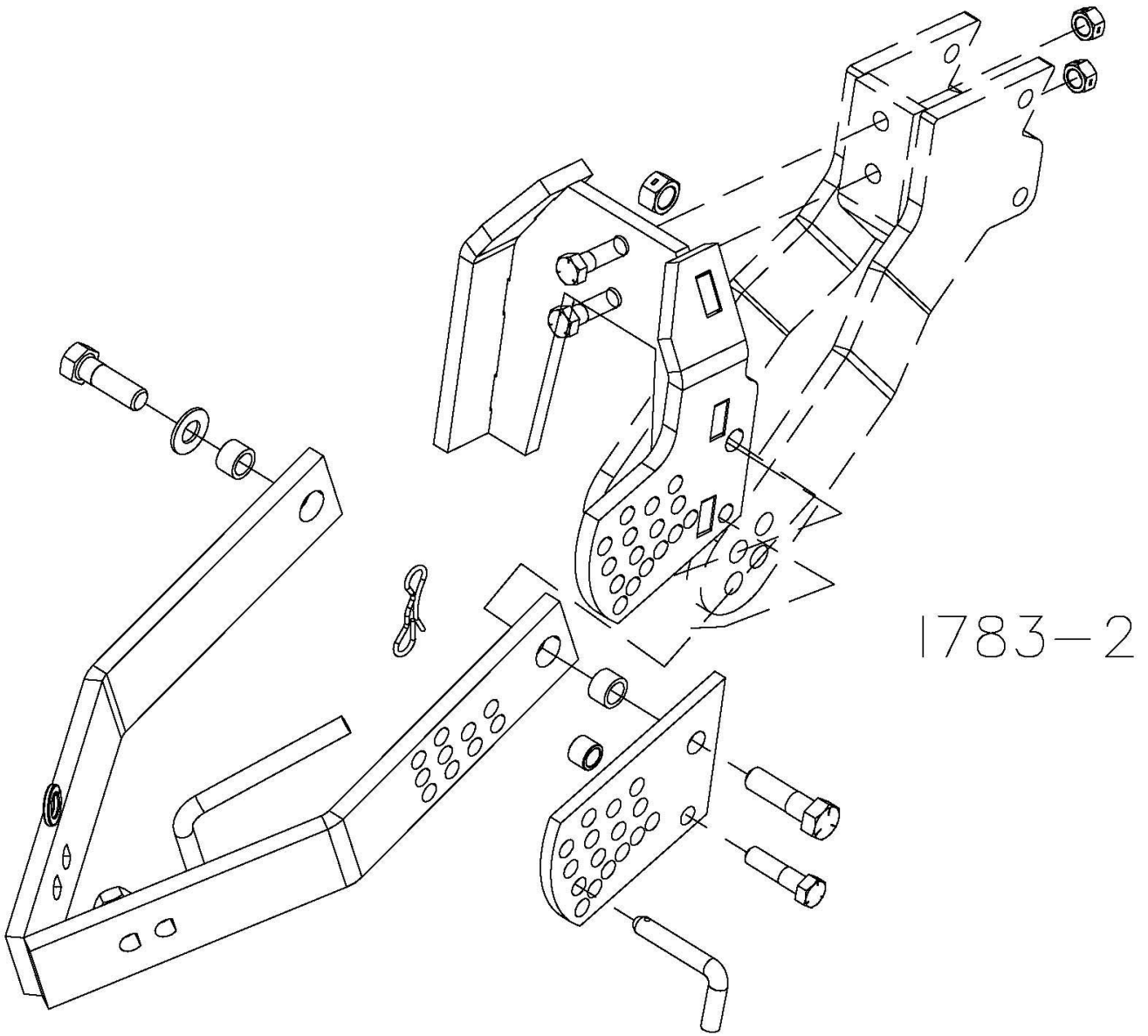

STEP 2. Attach the 2966-252 combo arm to the 2966-253 mount bracket using the 5/8" bolts, flat washers, bushings, 2967-623 adjustment plate and 5/8" lock nuts. Also, install the 1/2" x 2" bolt, 2967-622 spacer, 1/2" lock nut, 2984-326 pin and 2570-446 bowtie cotter on the 2967-623 adjustment plate.

INSTALLATION INSTRUCTIONS

STEP 3. Choose the mounting hole in which to attach the R.M. wheels. Attach the R.M. wheel/hub assemblies to the 2966-252 Combo Arm using the 5/8" hex nuts. Adjust the bearing shield (optional) to top dead center, rotate slightly forward. **Torque to 190 ft./lbs.**

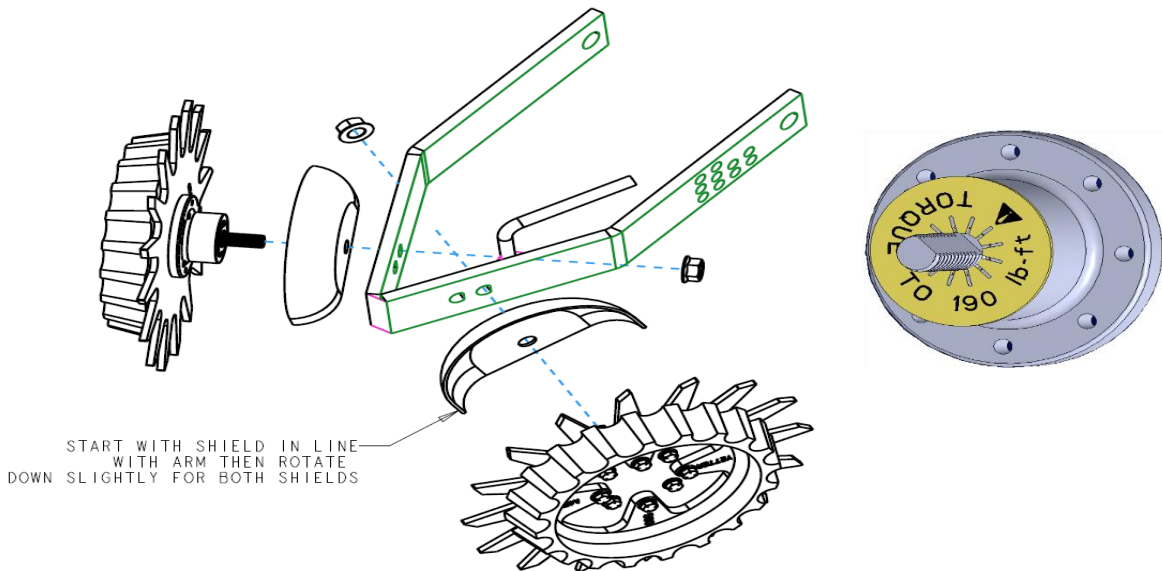

MOUNTING CONFIGURATIONS FOR RESIDUE WHEELS

- 2967-404 – 13" TAPER TOOTH SPOKE WHEEL
- 2967-596 – 3/8" HEAVY DUTY SPOKE WHEEL
- 2967-602 – 13" SHARKTOOTH WHEEL
- 2967-388 – 10" TAPER TOOTH SPOKE WHEEL

BOTH BACK

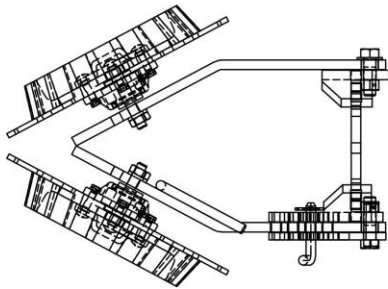

R.H. FRONT
L.H. BACK

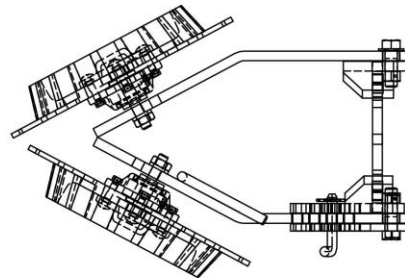

1783-11

BOTH FRONT

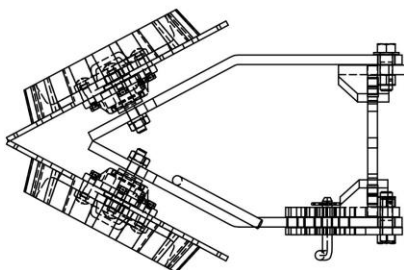

L.H. FRONT
R.H. BACK

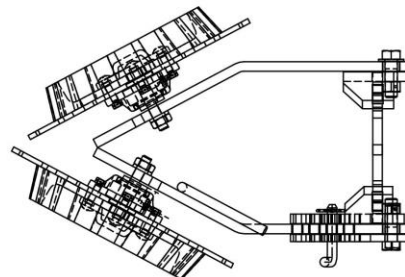

OPERATION



NOTICE: Where rocks are present the residue manager should be set in the “float” position, not locked down.

Adjust the residue manager to move crop residue aside and not move any soil. Adjustments to the residue manager may have to be made when changing field conditions and type and amount of residue. Use the handle for leverage when changing depth settings.

“FLOAT SETTINGS”

Install the adjustment pin below the combo arm.

To raise the wheels, lift the 2966-252 and move the adjustment pin up.

To lower the wheels, move the adjustment pin down.

“RIGID SETTING”

Install the adjustment pin through the combo arm.

To raise the wheels, lift the 2966-252-combo arm to the desired position and insert the pin. To lower the wheels, lower the combo arm to the desired position and insert the pin.

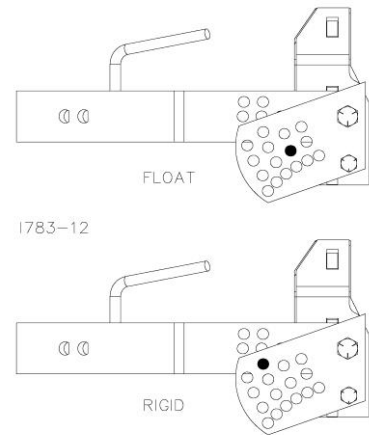

ROW CLEANER DO'S AND DON'TS

1. **DO NOT** move soil; Residue Managers are designed to move crop residue only.
2. **DO NOT** operate planter at slow speeds, ground speed affects how aggressive the spoke wheels are; operate at sufficient speed (4-6 mph) to maintain good residue flow.
3. **DO NOT** expect 100% of crop residue to be cleared, it is not necessary and would necessitate engaging the soil. The width of path cleared depends on ground conditions, depth setting and ground speed.
4. **DO** expect to see wheels occasionally quit turning, indicates ideal (shallow) setting which is not moving soil.
5. **DO** adjust toolbar frame height 20”-22” and drawbar to “level” correctly. Very important to ensure planter opener will follow ground contours properly.

OPTION

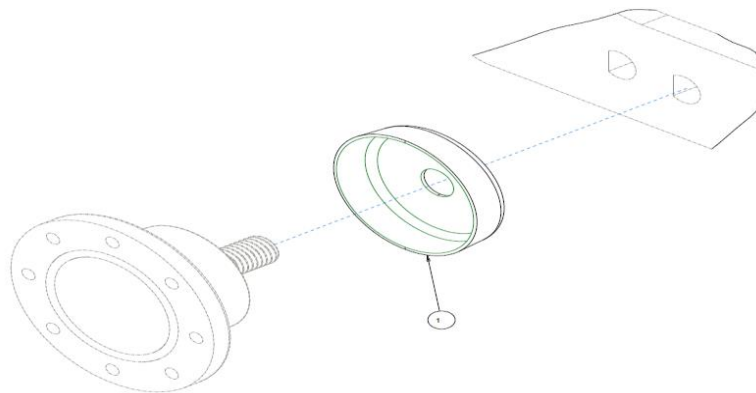

ITEM	PART NO.	DESCRIPTION	QTY.
1	2965-550	BEARING SHIELD	1

PARTS IDENTIFICATION 2967-008A-ST-FW

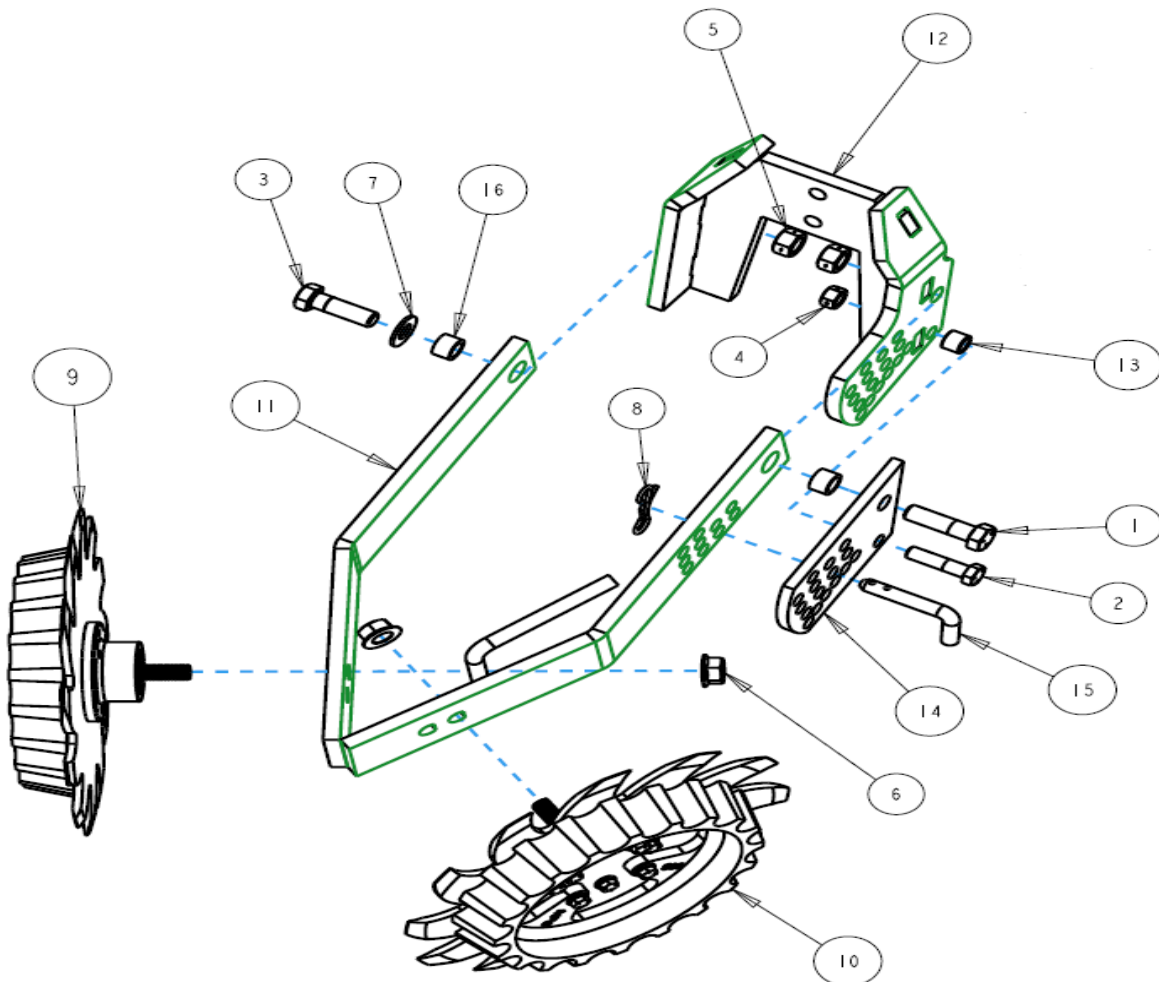

ITEM	PART NO.	DESCRIPTION	QTY
1	2502-332	5/8-11 X 2-1/4 HHCS GR5 ZP	1
2	2502-351	1/2-13 X 2 HHCS GR.5 ZP	1
3	2502-391	5/8-11 X 2 HHCS GR 5 ZP	1
4	2520-357	1/2-13 LOCK HEX NUT, GR A, ZP	1
5	2520-459	5/8-11 LOCK HEX NUT, GR B, ZP	2
6	2520-465	5/8-11 SER. FLANGE NUT, GR 8, ZP	2
7	2526-453	5/8 SAE FLATWASHER ZP	1
8	2570-448	.120 BOWTIE LOCKING COTTER ZP	1
9	2966-140-ST-FW	SHRKTH ASSY,RH,3"D-BOLT FLT WL	1
10	2966-141-ST-FW	SHRKTH ASSY,LH,3"D-BOLT FLT WL	1
11	2966-252	COMBO ARM W.A.	1
12	2966-253	R.M. MOUNT W.A. CNH	1
13	2967-622	9/16" SPACER ZP	1
14	2967-623	ADJUSTING PLATE BACKER	1
15	2984-326	R.M. UPSTOP PIN ZP	1
16	6000-335	9/16" BUSHING	2

PARTS IDENTIFICATION

2966-140-ST-FW

ITEM	PART NO.	DESCRIPTION	QTY
1	2502-220	5/16-18 X 3/4 HHFS GR5 ZP	4
2	2502-221	5/16-18 X 1 HHFS GR5 ZP	4
3	2515-562	13" WHEEL COVER, BLACK	2
4	2571-286	SHARKTOOTH WHEEL, 8 BOLT	1
5	2965-500	HUB ASSEMBLY, 1.406 SPINDLE	1
6	2967-560	FLOATER WHEEL	1

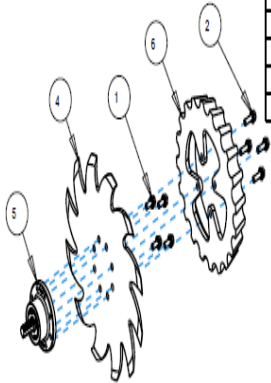

2966-140-ST-PFW

ITEM	PART NO.	DESCRIPTION	QTY
1	2502-220	5/16-18 X 3/4 HHFS GR5 ZP	4
2	2502-221	5/16-18 X 1 HHFS GR5 ZP	4
3	2571-286	SHARKTOOTH WHEEL, 8 BOLT	1
4	2965-500	HUB ASSEMBLY, 1.406 SPINDLE	1
5	2967-957	SHARKTOOTH TIMED FLOATER WHEEL	1

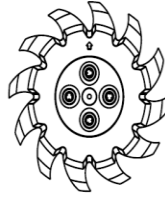

LINE UP ARROW ON FLOATER WITH SLOT ON WHEEL TO INSURE PROPER TIMING OF NOTCHES.

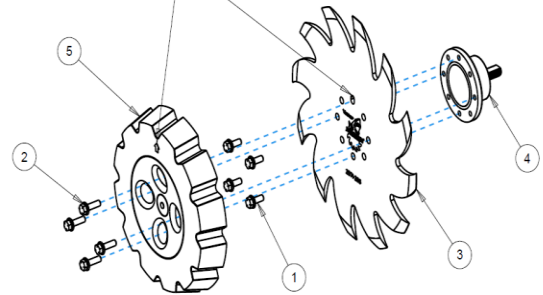

2966-140-STF-PFW RIGHT HAND SHARKTOOTH FINGER WHEEL ASSEMBLY

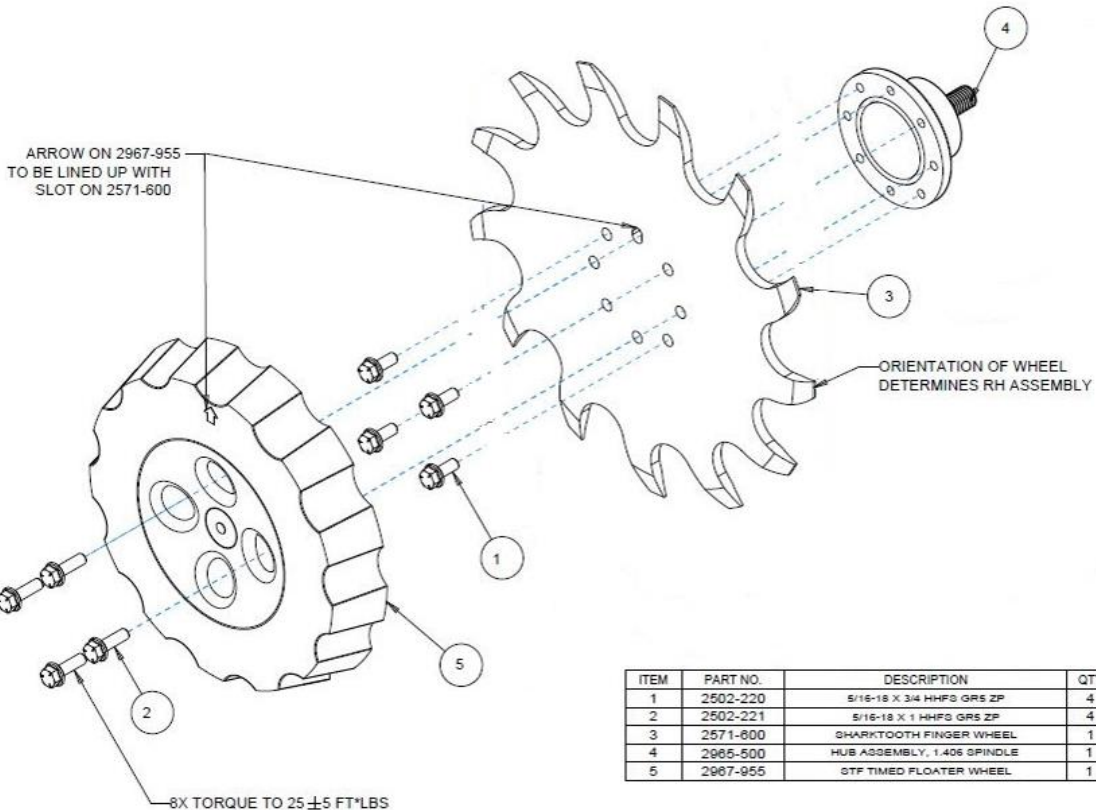

ITEM	PART NO.	DESCRIPTION	QTY
1	2502-220	5/16-18 X 3/4 HHFS GR5 ZP	4
2	2502-221	5/16-18 X 1 HHFS GR5 ZP	4
3	2571-600	SHARKTOOTH FINGER WHEEL	1
4	2965-500	HUB ASSEMBLY, 1.406 SPINDLE	1
5	2967-955	STF TIMED FLOATER WHEEL	1

PARTS IDENTIFICATION

2966-140-BW-FW

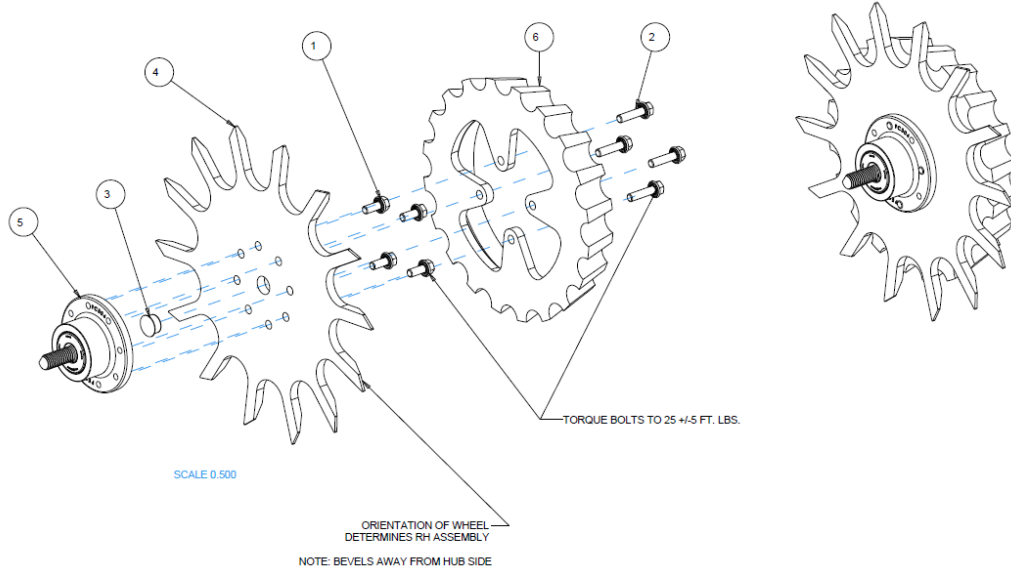

ITEM	PART NO.	DESCRIPTION	QTY
1	2502-220	5/16-18 X 3/4 HHFS GR5 ZP	4
2	2502-222	5/16-18 X 1-1/4 HHFS GR5 ZP	4
3	2570-994	BEVEL WHEEL CENTER HOLE PLUG	1
4	2571-287-R	13" BEVEL WHEEL, 8 BOLT, RH	1
5	2965-500	HUB ASSEMBLY, 1.406 SPINDLE	1
6	2967-560	FLOATER WHEEL	1

2966-141-FW

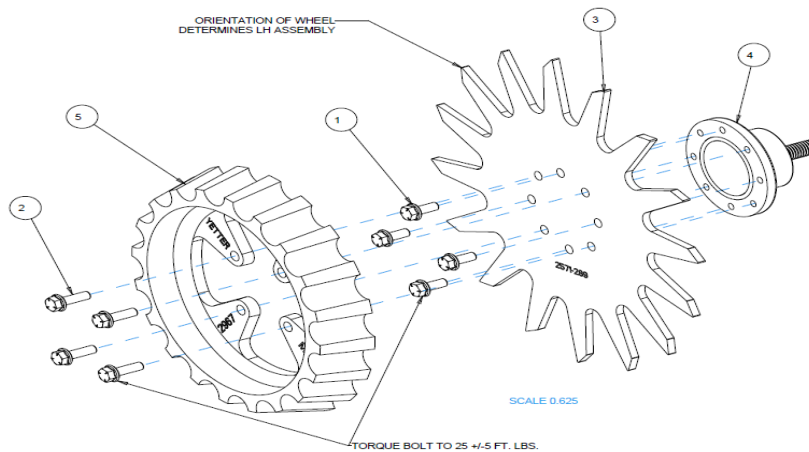

ITEM	PART NO.	DESCRIPTION	QTY
1	2502-220	5/16-18 X 3/4 HHFS GR5 ZP	4
2	2502-221	5/16-18 X 1 HHFS GR5 ZP	4
3	2571-289	13" TAPER TOOTH SPOKE WHEEL, 8 BOLT	1
4	2965-500	HUB ASSEMBLY, 1.406 SPINDLE	1
5	2967-560	FLOATER WHEEL	1

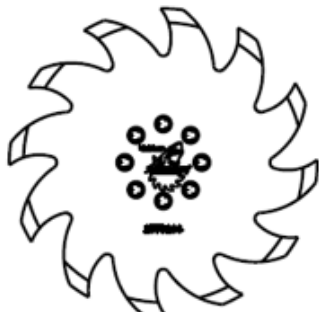

SHARKTOOTH WHEEL ASSEMBLY
RIGHT HAND 2966-140-ST(SHOWN)
LEFT HAND 2966-141-ST



SHARKTOOTH WHEEL ASSEMBLY W/FLOATER WHEEL
RIGHT HAND 2966-140-ST-FW(SHOWN)
LEFT HAND 2966-141-ST-FW



SHARKTOOTH WHEEL ASS'Y W/POLY FLOATER WHEEL
RIGHT HAND 2966-140-ST-PFW(SHOWN)
LEFT HAND 2966-141-ST-PFW



BEVEL WHEEL ASSEMBLY
RIGHT HAND 2966-140-BW(SHOWN)
LEFT HAND 2966-141-BW



BEVEL WHEEL ASSEMBLY W/FLOATER WHEEL
RIGHT HAND 2966-140-BW-FW(SHOWN)
LEFT HAND 2966-141-BW-FW

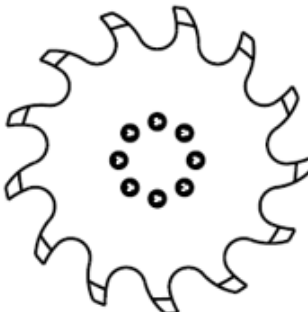

SHARKTOOTH FINGER WHEEL ASSEMBLY
RIGHT HAND 2966-140-STF(SHOWN)
LEFT HAND 2966-141-STF

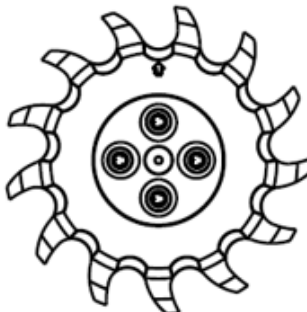

SHARKTOOTH FINGER WHEEL ASSEMBLY W/FLOATER WHEEL
RIGHT HAND 2966-140-STF-FW(SHOWN)
LEFT HAND 2966-141-STF-FW

ISO2966-140_ASSEMBLIES

8 BOLT HUB ASSEMBLY

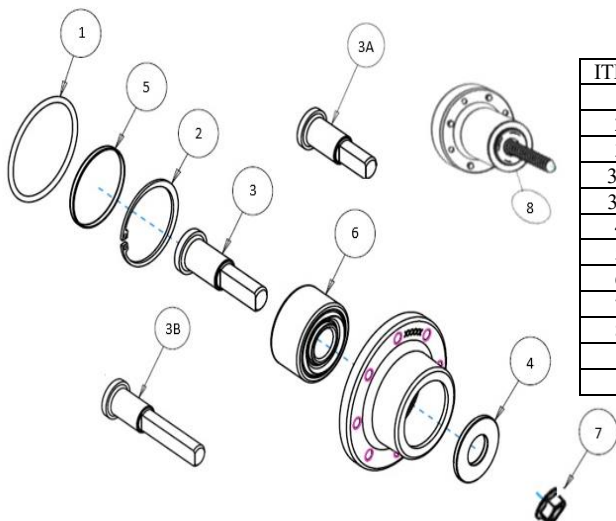

ITEM	PART #	DESCRIPTION	QTY
1	2550-074	O-RING 3.55MM X 56MM ID	1
2	2550-529	SNAP RING	1
3	2965-600A	SHAFT 73 MM (2965-500A HUB ASSEMBLY)	1
3A	2965-602A	SHAFT 66.7 MM (2965-502A HUB ASSEMBLY)	1
3B	2965-601A	SHAFT 98.4 MM (2965-501A HUB ASSEMBLY)	1
4	2965-604A	SPACER	1
5	2965-605A	CAP	1
6	2965-606	BEARING	1
7	2520-465	5/8-11 FLANGE HEX NUT GRADE 8	1
8	2965-500A	HUB ASSEMBLY 1.406" SPINDLE	1
	2965-501A	HUB ASSEMBLY 2.406" SPINDLE	1
	2965-502A	HUB ASSEMBLY 1.157" SPINDLE	1

FIELD SERVICE KITS

- 2965-119 - SERVICE KIT FOR 2570-740-2.812 D-BOLT
- 2965-120 - SERVICE KIT FOR 2570-742-3.812 D-BOLT
- 2965-121 - SERVICE KIT FOR 2570-766-2.562 D-BOLT

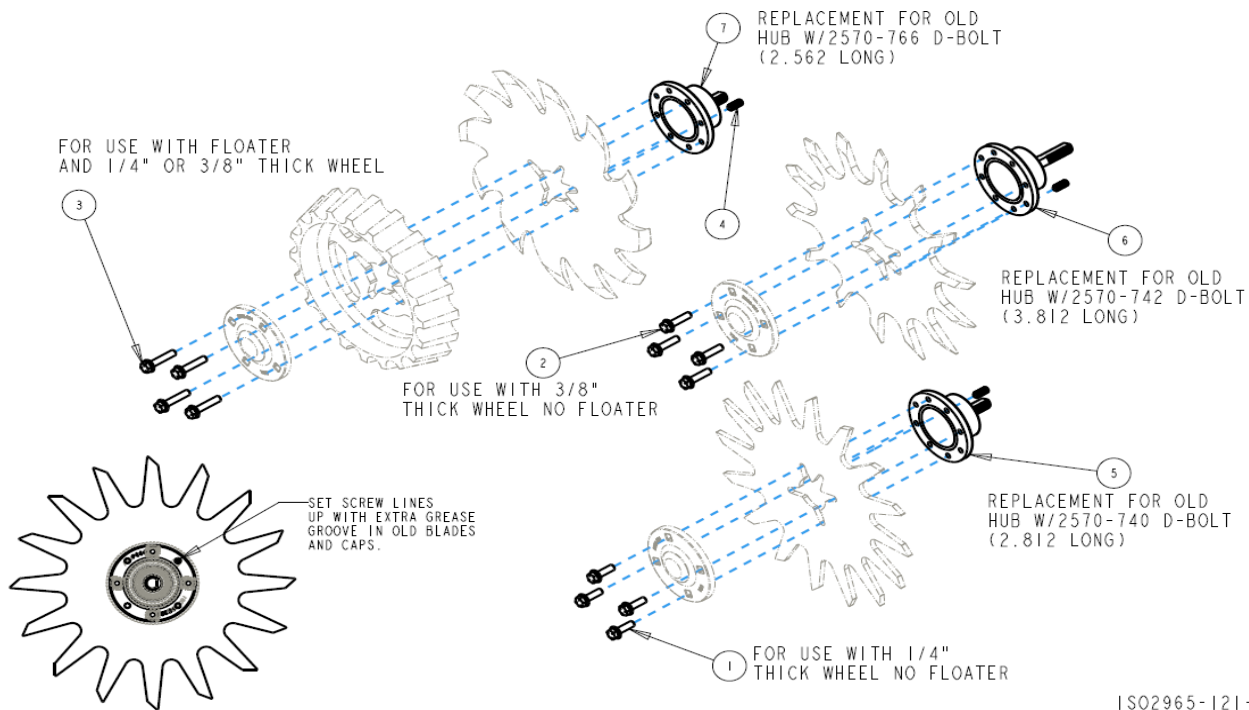

ISO2965-121-2

ITEM	PART NO	DESCRIPTION	QTY
1	2502-221	5/16-18 X 1 HHFS GRADE 5	4
2	2502-222	5/16-18 X 1-1/4 HHFS GRADE 5	4
3	2502-225	5/16-18 X 1-1/2 HHFS GRADE 5	4
4	2940-560	SET SCREW	1
5	2965-500	HUB ASSEMBLY 1.406 SPINDLE	1
6	2965-501	HUB ASSEMBLY 2.406 SPINDLE	1
7	2965-502	HUB ASSEMBLY 1.157 SPINDLE	1

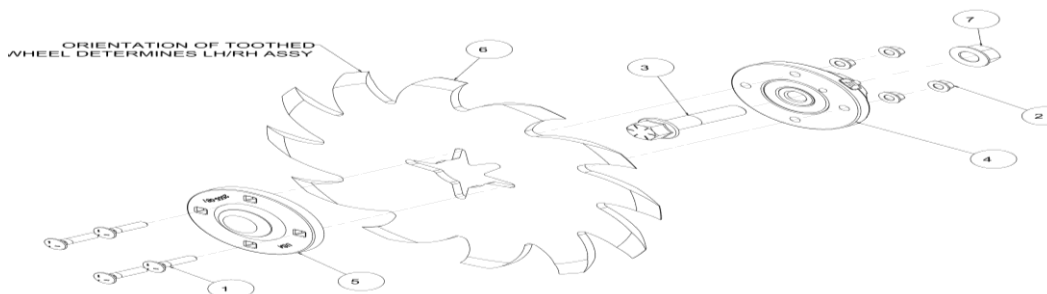

ITEM	PART NO	DESCRIPTION	QTY
1	2505-207	5/16-18 X 1-1/4 CARRIAGE HEAD BOLT GRADE 5	4
2	2520-206	5/16-18 FLANGE LOCK NUT	4
3	2570-740	D-BOLT FLANGE HEAD 5/8-11 X 2.812 GRADE 8	1
4	2965-128	HUB/BEARING ASSEMBLY	1
	2550-069	SEAL	1
	2570-594	BEARING	1
	2570-715	INSERT	1
	2965-351	HUB	1
	2533-110	GREASE FITTING	1
5	2965-352	HUB CAP	1
6	2967-602	SHARK TOOTH WHEEL	1
7	2520-465	5/8-11 FLANGE LOCK NUT GRADE 8	1



A Tradition of Solutions since 1930

Yetter Farm Equipment Co

PO BOX 358 109 S. McDonough

Colchester, IL 62326-0358

Phone: 309-776-4111

Toll Free: 800-447-5777

Email: info@yetterco.com

For updated models and manuals visit the Yetter website:

www.yetterco.com

© Yetter Farm Equipment Co. All Rights Reserved

2565-695_REV_P • 06/2026