



**2962-003A / 2962-004A LIQUID
2962-010A / 2962-011A GRANULAR
2962-005B RESIDUE MANAGER**

R.U.M.D.D.F.O.

ROW UNIT MOUNTED DOUBLE DISC FERTILIZER OPENER

OPERATOR'S MANUAL

PARTS IDENTIFICATION

2565-954-REV-F • 06/2026

YETTER MANUFACTURING CO.

FOUNDED 1930

Colchester, IL 62326-0358

Toll free: 800/447-5777

309/776-3222 (Fax)

Website: www.yetterco.com

E-mail: info@yetterco.com

YETTER

FOREWORD

You've just joined an exclusive but rapidly growing club.
For our part, we want to welcome you to the group and thank you for buying a Yetter product.

We hope your new Yetter products will help you achieve both goals-increase your productivity and increase your efficiency so that you may generate more profit.

This operator's manual has been designed into four major sections: Foreword, Safety Precautions, Installation Instructions and Parts Breakdown.

This **SAFETY ALERT SYMBOL** indicates important safety messages in the manual. When you see this symbol, be alert to the possibility of **PERSONAL INJURY** and carefully read the message that follows.

 **DANGER:** Indicates an imminently hazardous situation which, if not avoided "will" result in death or serious injury. This signal word is to be limited to the most extreme situations

 **WARNING:** Indicates a potentially hazardous situation which, if not avoided, "could" result in death or serious injury.

 **CAUTION:** Indicates a potentially hazardous situation, which if not avoided, "may" result in minor or moderate injury. It may also be used to alert against unsafe practices.

 **NOTICE:** Indicates information considered important, but not hazard related (e.g., messages relating to property damage).

It is the responsibility of the user to read the operator's manual and comply with the safe and correct operating procedure and to lubricate and maintain the product according to the maintenance schedule in the operator's manual.

The user is responsible for inspecting his machine and for having parts repaired or replaced when continued use of the product would cause damage or excessive wear to the other parts.

It is the user's responsibility to deliver his machine to the Yetter dealer who sold him the product for service or replacement of defective parts, which are covered by the warranty policy.

If you are unable to understand or follow the instructions provided in this publication, consult your local Yetter dealer or contact:

YETTER MANUFACTURING CO.

309/776-4111

800/447-5777

309/776-3222 (FAX)

Website: www.yetterco.com

E-mail: info@yetterco.com

WARRANTY POLICY

Yetter Manufacturing warrants all products manufactured and sold by it against defects in material. This warranty being expressly limited to replacement at the factory of such parts or products as will appear to be defective after inspection. This warranty does not obligate the Company to bear cost of labor in replacement of parts. It is the policy of the company to make improvements without incurring obligations to add them to any unit already sold. No warranty is made or authorized to be made, other than herein set forth. This warranty is in effect for one year after purchase.

Dealer : _____

Yetter Manufacturing warrants its own products only and cannot be responsible for damage to equipment on which mounted.



SAFETY PRECAUTIONS



A brief description of signal words that may be used in this manual:

DANGER: Indicates an imminently hazardous situation which, if not avoided, “will” result in death or serious injury. This signal word is to be limited to the most extreme situations.

WARNING: Indicates a potentially hazardous situation which, if not avoided, “could” result in death or serious injury.

CAUTION: Indicates a potentially hazardous situation, which if not avoided, “may” result in minor or moderate injury. It may also be used to alert against unsafe practices.

NOTICE: Indicates information considered important, but not hazard related (e.g., messages relating to property damage).

Consult your implement and tractor operator’s manual for correct and safe operating practices. Be aware of towed implement width and allow safe clearance.

Safety decals are placed on the implement to alert the operator and others to the risk of personal injury or unsafe operation during normal operations and servicing.

1. The safety decals must be kept clean and in good condition to ensure that they are legible.
2. Safety decals must be replaced if they are missing or illegible.
3. When components are replaced during repair or servicing, check that the new components include the necessary safety signs.
4. Replacement safety decals may be obtained from your local dealer.



WARNING

Read these instructions carefully to acquaint yourself with the Equipment. Working with unfamiliar equipment can lead to accidents.

Never park the equipment on a steep incline or leave the equipment running unattended.

Never clean, lubricate or adjust a machine that is in motion.

Always check that straps are secure.

Make sure latches are in pinned position when moving equipment.

Do not allow children to operate this equipment.

Do not allow riders on the equipment, trailer and/or pick-up.

Use speed and caution dictated by the terrain being traversed. Do not operate on any slope steep enough to cause tipping or loss of control.

Read and understand the operator’s manual and require all other persons who will operate the equipment to do the same.

If operating on public roadways, where legal, be certain all lighting is operating properly and observe all traffic laws.

Beware of increased stopping distances and control effort when operating with implements attached.

Be familiar with all controls and be prepared to stop equipment quickly in an emergency.

FAILURE TO HEED MAY RESULT IN PERSONAL INJURY OR DEATH.

BOLT TORQUE

Mounting bolts and hardware

Before operating the 2962 R.U.M.D.D.F.O. for the first time, check to be sure that all hardware is tight. Check all hardware again after approximately 50 hours of operation and at the beginning of each planting season.

All hardware used on the 2962 R.U.M.D.D.F.O. is Grade 5 unless otherwise noted. Grade 5 cap screws are marked with three radial lines on the head. If hardware must be replaced, be sure to replace it with hardware of equal size, strength and thread type. Refer to the torque values chart when tightening hardware.





NOTICE: Over tightening hardware can cause as much damage as when under tightening. Tightening hardware beyond the recommended range can reduce its shock load capacity.

The chart below is a guide for proper torque. Use it unless a specified torque is called out elsewhere in the manual.

Torque is the force you apply to the wrench handle or the cheater bar, times the length of the handle or bar.

Use a torque wrench whenever possible.

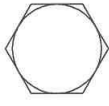
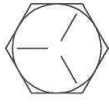
The following table shows torque in ft. lbs. for coarse thread hardware.

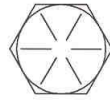
BOLT DIA. AND THREADS PER INCH	 GRADE 2	 OR  GRADE 5 A-325	 GRADE 8
3/8-16	25	35	50
7/16-14	35	55	80
1/2-13	55	85	125
9/16-12	75	125	175
5/8-11	105	170	235
3/4-10	185	305	425
7/8-9	170	445	690
1-8	260	670	1030
1 1/8-7	365	900	1460
1 1/4-7	515	1275	2060
1 3/8-6	675	1675	2700
1 1/2-6	900	2150	3500
1 3/4-5	1410	3500	5600

Lubricate all bearings and moving parts as assembled and make certain that they work freely.



WARNING: Never work around the toolbar/implement while in a raised position without using safety lockups.



CAUTION: The 2962 R.U.M.D.D.F.O. is very heavy. Pay extra attention to lifting techniques while handling and or maneuvering the opener during assembly. Failure to do so may lead to personal injury.

OPERATION PRECAUTIONS

STOP

Read this before using the Yetter product.

- MACHINE OPERATION



NOTICE: failure to properly set the planter frame height and levelness can result in less than successful operation of the planter and the Yetter product and may result in damaged equipment. All operators should read and thoroughly understand the instructions given prior to using the Yetter product.

DO NOT use this product if the planter is not adjusted properly!

Leveling the planter:

With the planter lowered to proper operating height (**Usually 20”-22”**). **Read the planter operator’s manual for recommended setting**. Check to be sure the toolbar and row unit parallel arms are level fore and aft. **Re-check** when the planter is in the **field** and has been **fully loaded** with seed, fertilizer, granular chemicals, etc. Also, a field check with a bubble level on the frame should be made of the hitch height to ensure level operation front to back.

It is important for the planter to operate level laterally. Tire pressure must be maintained at pressures specified by the manufacturer.

Field and actual planting conditions change and will dictate planter frame heights. You must ensure that the row unit parallel arms are approximately parallel with the ground.



NOTICE: For proper operation of the planter attachments and row units, it is imperative that the planter toolbars and row unit parallel arms be level side-to-side and front-to-rear. The toolbar frame should operate at a 20”-22” height from the **planting surface**. Check the manufacturer’s operator’s manual for instructions on how to adjust the frame height and levelness.

PLANTER ADJUSTMENT

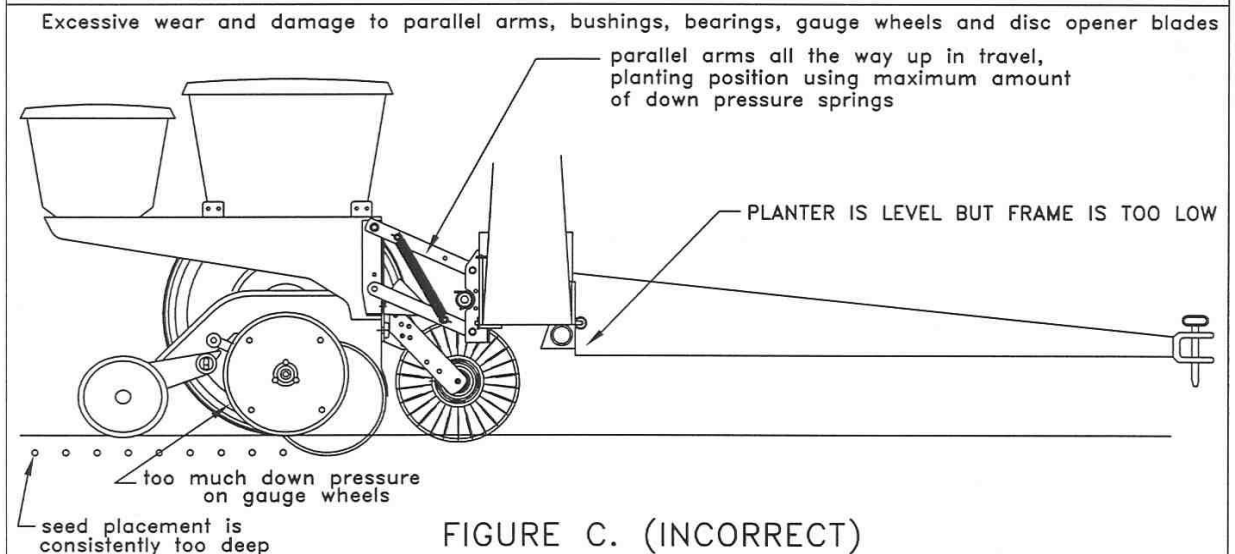
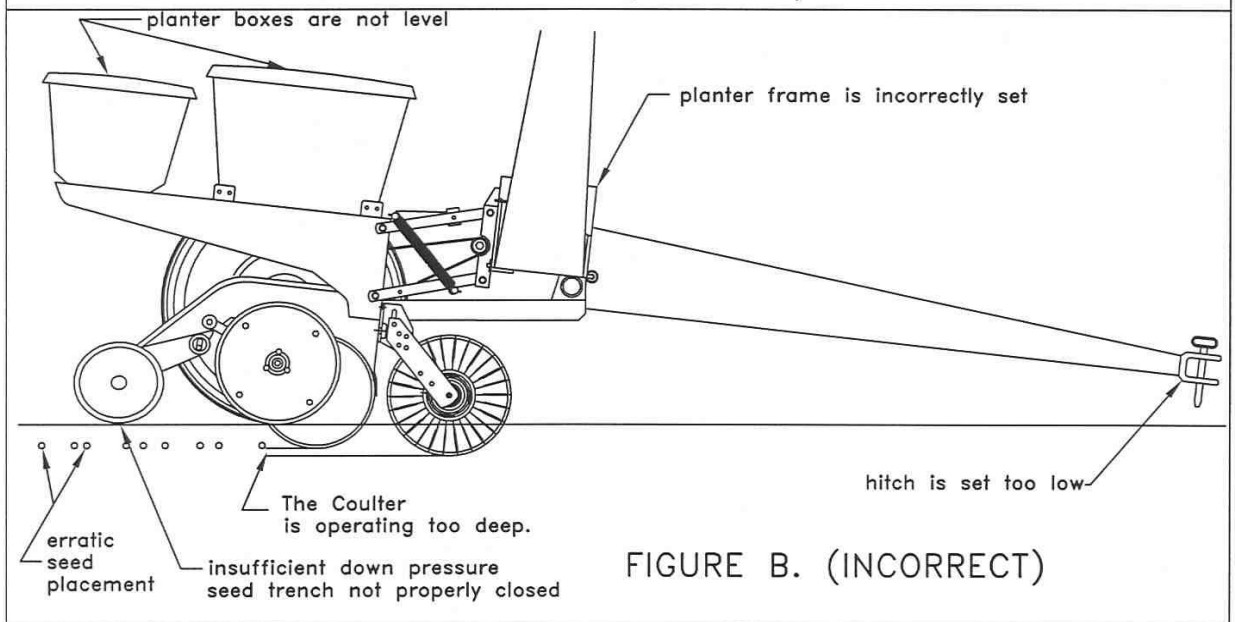
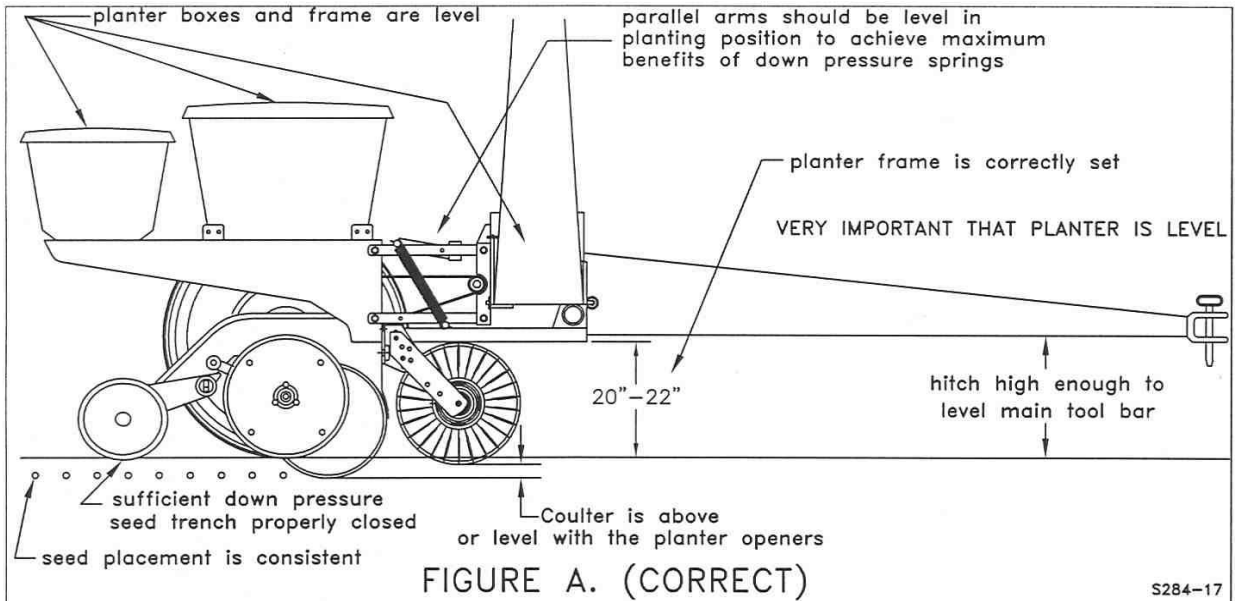

PLANTER ADJUSTMENT

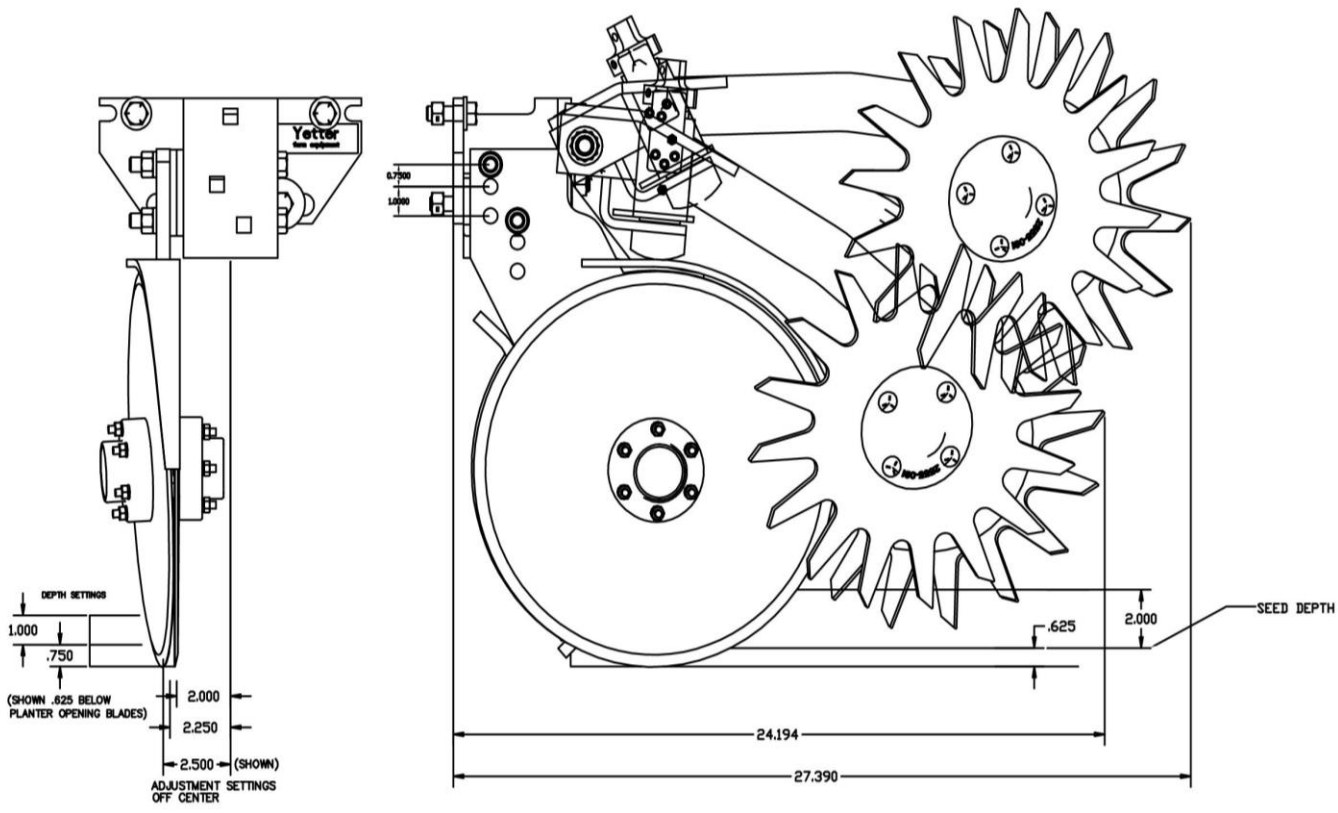

1798



NOTICE: Torque the bearing assemblies at **190 ft.lbs**

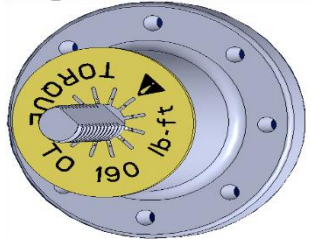

ADJUSTING DEPTH

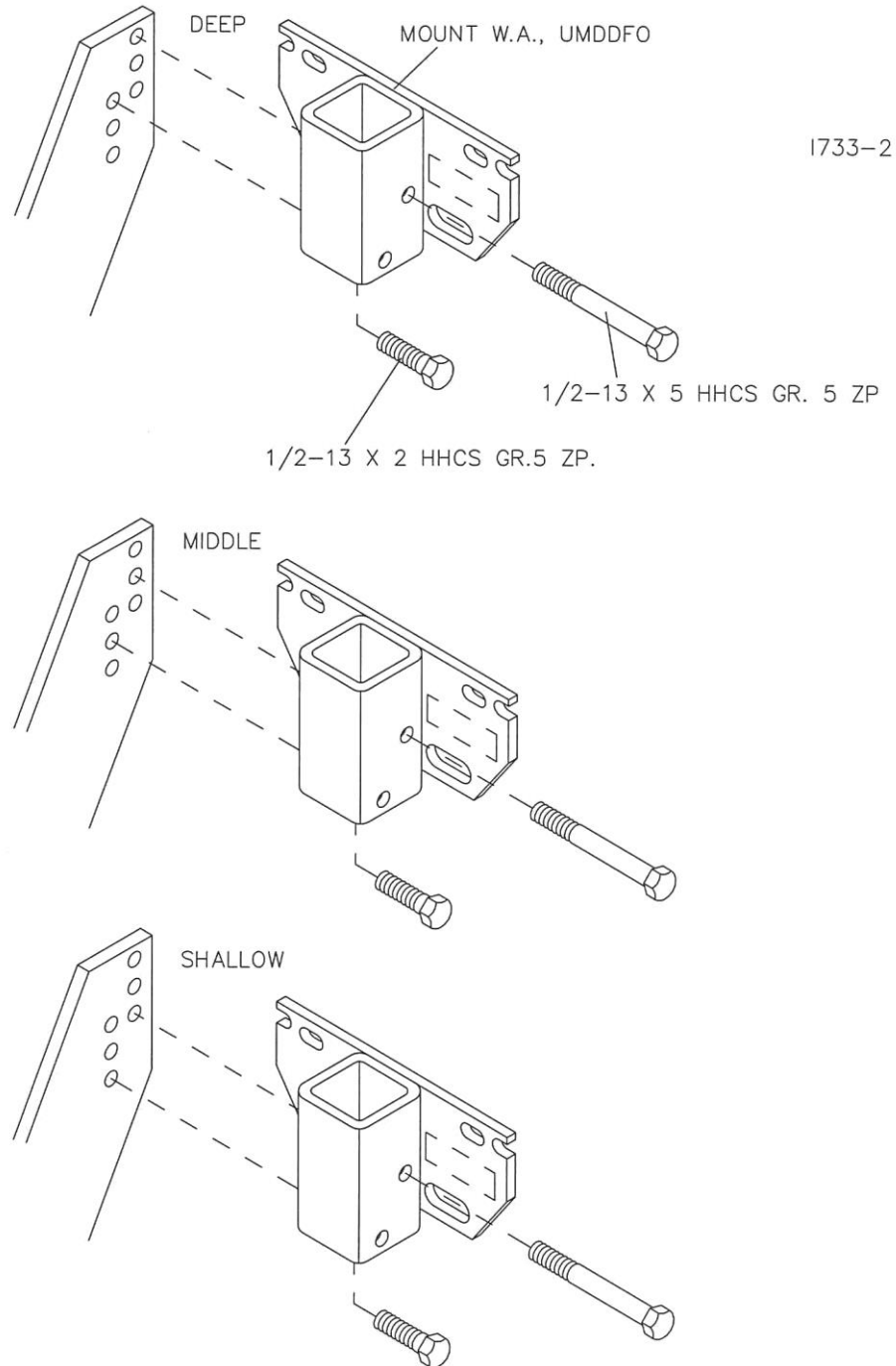

Row Unit Mounted Double-Disk Fertilizer openers will perform in conventional, reduced and light no-till conditions but are not recommended for double-crop or tough no-till conditions. The double-disk design limits penetration in no-till or double-crop conditions. Single disk openers are better suited for no-till conditions.

ADJUSTING FERTILIZER TO SEED FURROW

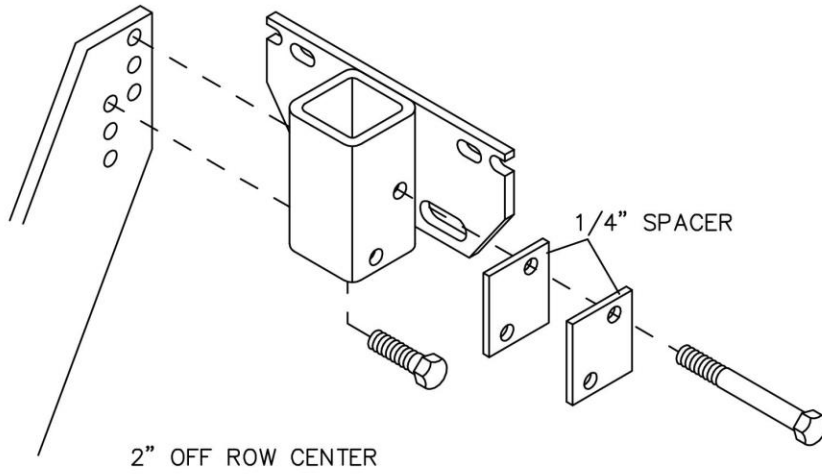
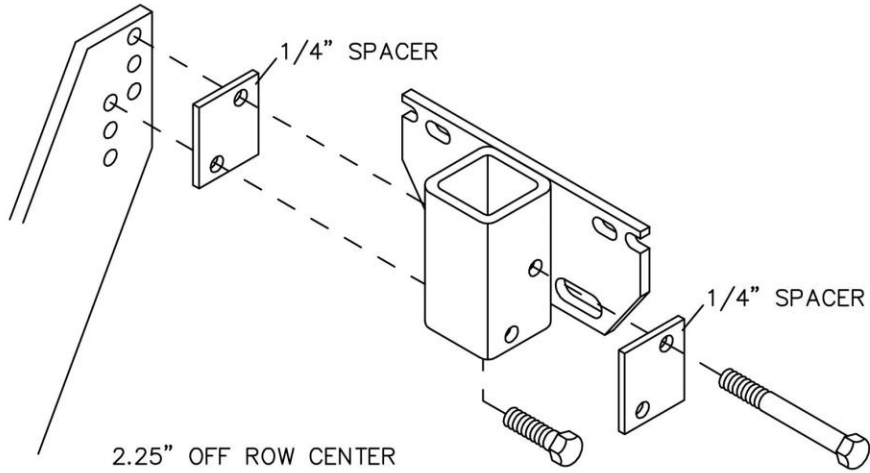
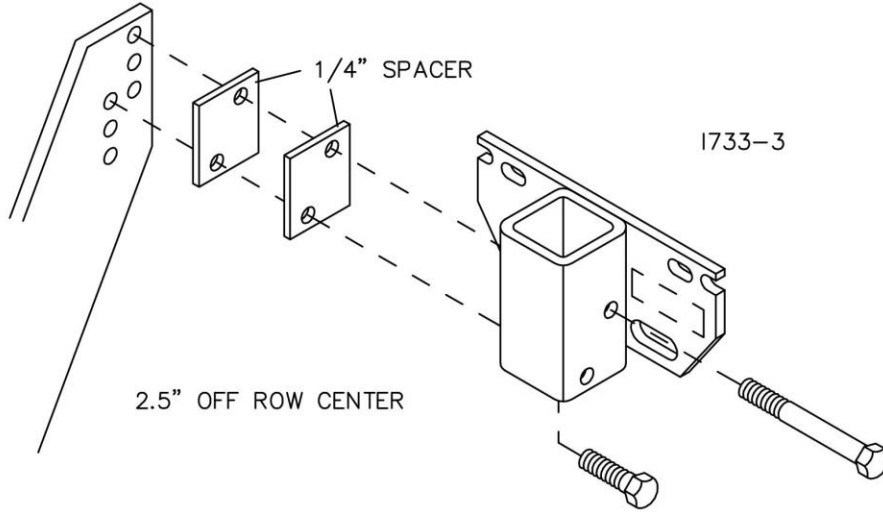

MAINTENANCE

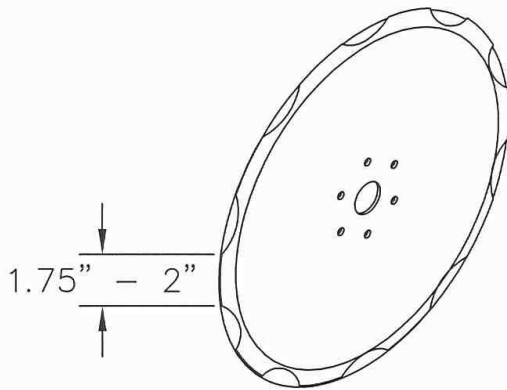
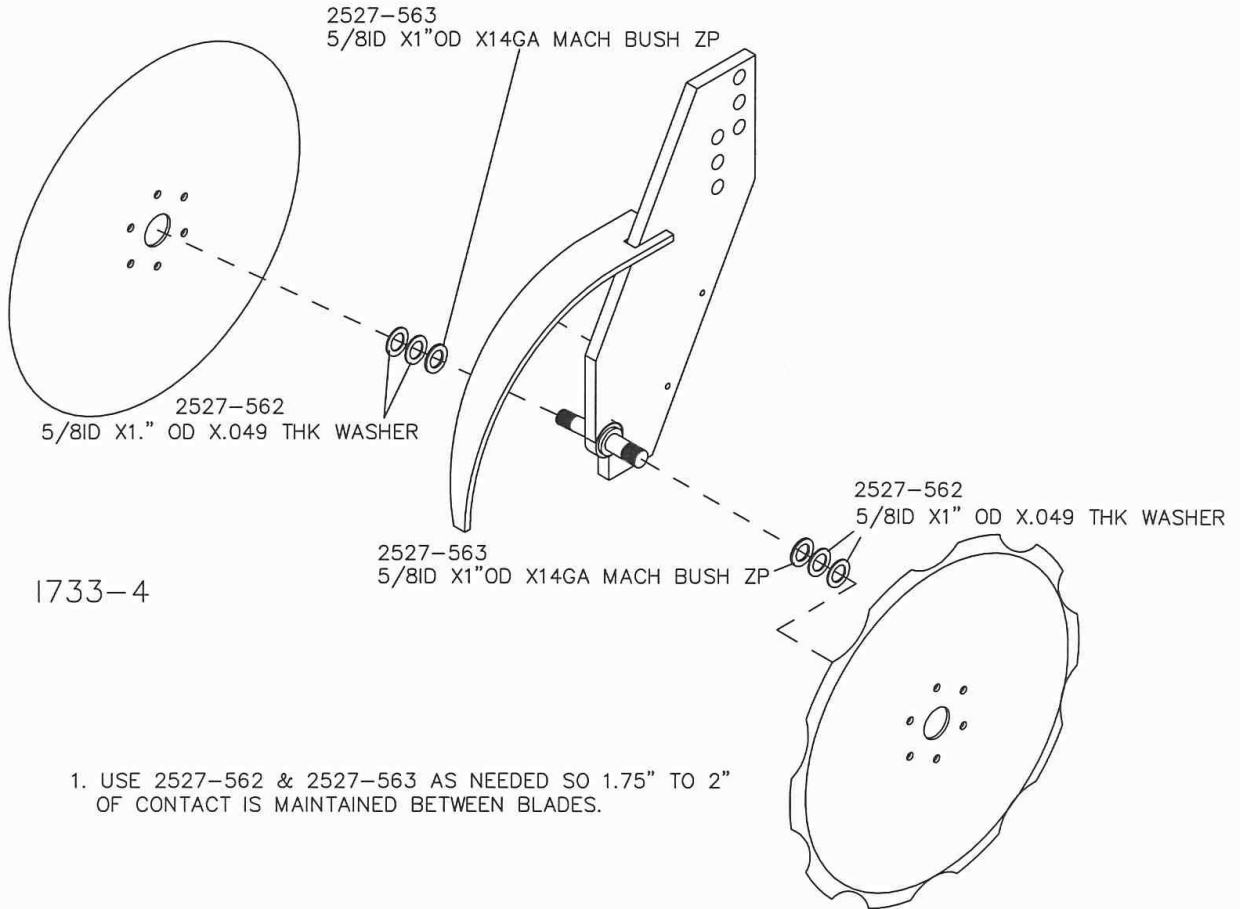

MAINTENANCE

Lubrication



CAUTION: To help prevent serious injury or death to you or others caused by unexpected movement, service machine on a level surface. Lower machine to ground or sufficiently lock or block raised machine before servicing. If machine is connected to tractor, engage parking brake and place transmission in "PARK", shut off engine and remove key. If machine is detached from tractor, block wheels and use shop stands to prevent movement. |



CAUTION: Do not clean, lubricate, or adjust machine while in motion.

Use grease based on NLGI consistency numbers and the expected air temperature range during the service interval.

Use a **multi-purpose polyurea**, water resistant, moderate speed, and NLGI grade #2 grease.

IMPORTANT: Some types of grease thickener are not compatible with others. Consult your grease supplier before mixing different types of grease.

Alternative Lubricants

Conditions in certain geographical areas may require special lubricants and lubrication practices which do not appear in the operator's manual. If there are any questions, consult Yetter Manufacturing Co. to obtain latest information and recommendation.

Storing Lubricants

Your machine can operate at top efficiency only if clean lubricants are used.

Use clean containers to handle all lubricants.

Store them in an area protected from dust, moisture and other contaminants.

MAINTENANCE Lubrication Symbols



Lubricate with grease at hourly interval indicated on symbol.

Lubrication Intervals

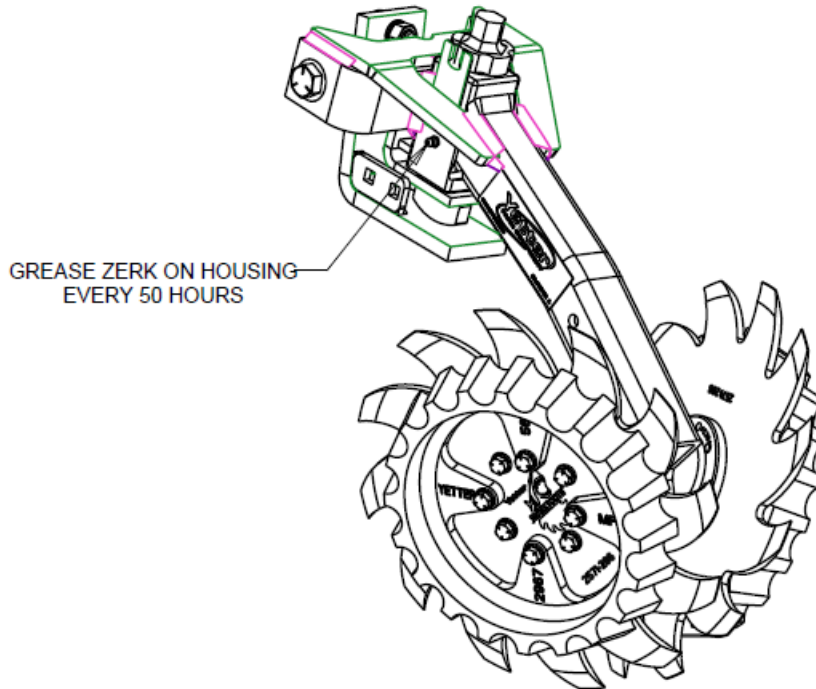

The recommended service intervals are based on normal conditions; severe or unusual conditions may require more frequent lubrication.

Perform each lubrication and service procedure at the beginning and end of each season. Clean grease fittings before using grease gun, to avoid injecting dirt and grit into the fitting. Replace any lost or broken fittings immediately. If a fitting fails to take grease, remove and clean thoroughly, replace fitting if necessary. Also check for failure of adjoining parts.

MAINTENANCE

Storing the Equipment

Store the machine in an area away from human activity

Store machine in RAISED position.

Install service locks on all wheel cylinders.

At the end of the season, the machine should be thoroughly inspected and prepared for storage. Repair or replace any worn or damaged components to prevent down time at the start of the next season. Store machine under cover with all parts in operating condition.

- Clean machine thoroughly to remove all dirt, debris and crop residue, which would hold moisture and cause rusting.
- Inspect machine for worn or broken parts. See your Yetter Farm Equipment dealer during the off-season so that parts or service can be acquired when machine is not needed in the field.
- Lubricate bearings as outlined in the Lubrication section
- Paint all parts which are chipped or worn and require repainting.
- Store machine in a clean, dry place with the planting unit out of the sun.
- If the machine cannot be stored inside, cover with a waterproof tarpaulin and tie securely in place.
- Do not allow children to play on or around the machine

OPTION

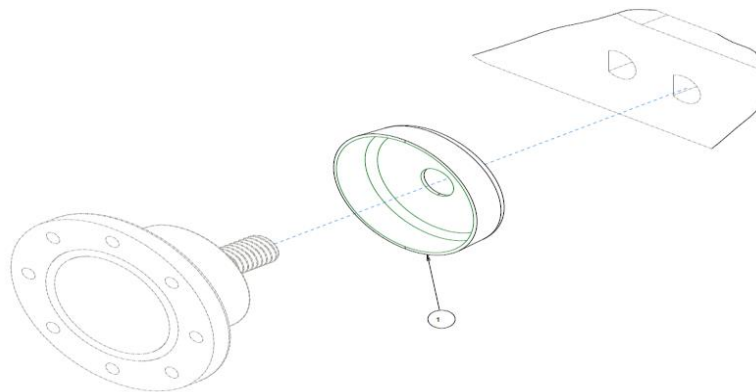

ITEM	PART NO.	DESCRIPTION	QTY.
1	2965-550	BEARING SHIELD	1

PARTS IDENTIFICATION
2962-003A
LEFT HAND DOUBLE DISC LIQUID

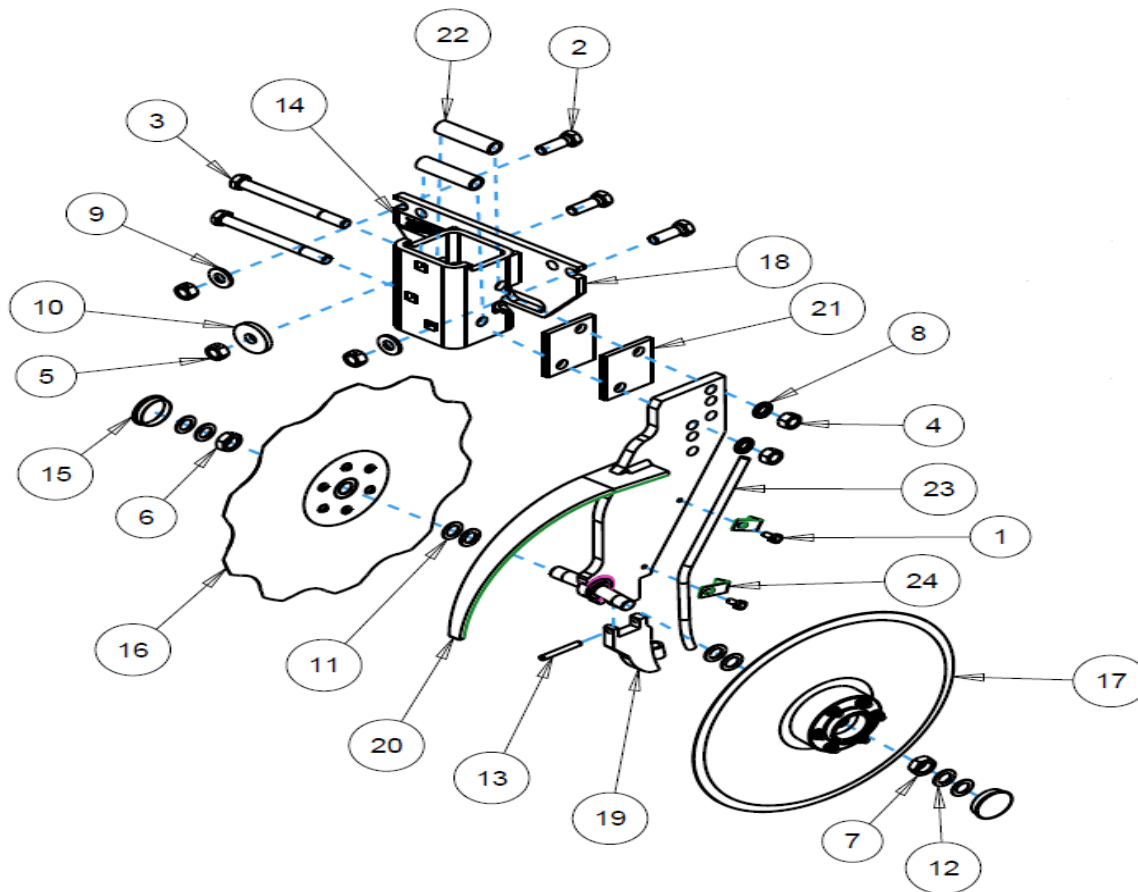

ITEM	PART NO.	DESCRIPTION	QTY
1	2502-104	1/4-20 X 1/2 HHCS GR. 5 ZYD.	2
2	2502-294	1/2-13 X 1-1/2 HHCS GR5 ZP	3
3	2502-368	1/2-13 X 5-1/2 HHCS GR5 ZP	2
4	2520-352	1/2-13 HEX NUT ZP	2
5	2520-357	1/2-13 LOCK HEX NUT, GR A, ZP	3
6	2520-453	5/8-11 JAM HEX NUT ZP	1
7	2520-466	5/8-11 L.H. JAM HEX NUT ZP	1
8	2525-352	1/2 MED LOCKWASHER ZP.	2
9	2526-355	1/2 FLAT WASHER HARD'ND ZP	2
10	2526-402	9/16ID X 1-3/4 OD X 1/4MBZP	1
11	2527-562	5/8ID X 1OD X .049+- .002M BU ZP	4
12	2527-563	5/8ID X 1"OD X 14GA MACH BU	4
13	2530-153	1/4 X 2 ROLL PIN ZP	1
14	2565-179	YETTER DECAL 1" X 3"	1
15	2570-543	HUB CAP, HARTFORD #10802	2
16	2962-129	NOTCHED BLADE ASSEMBLY (2016)	1
17	2962-130	SMOOTH BLADE ASSEMBLY (2016)	1
18	2962-206	MOUNT W.A. UMDDFO (2010)	1
19	2962-218	INTERNAL SCRAPER W.A. (2015)	1
20	2962-221	ARM W.A.(LH) UMDDFO (2016)	1
21	2962-302	.25" SPACER, RUMDDFO	2
22	2962-322	BUSHING	2
23	2962-334	LIQUID TUBE	1
24	2962-335	TUBE CLAMP	2

MFG 1/2017 TO PRESENT

PARTS IDENTIFICATION
2962-004A
RIGHT HAND DOUBLE DISC LIQUID

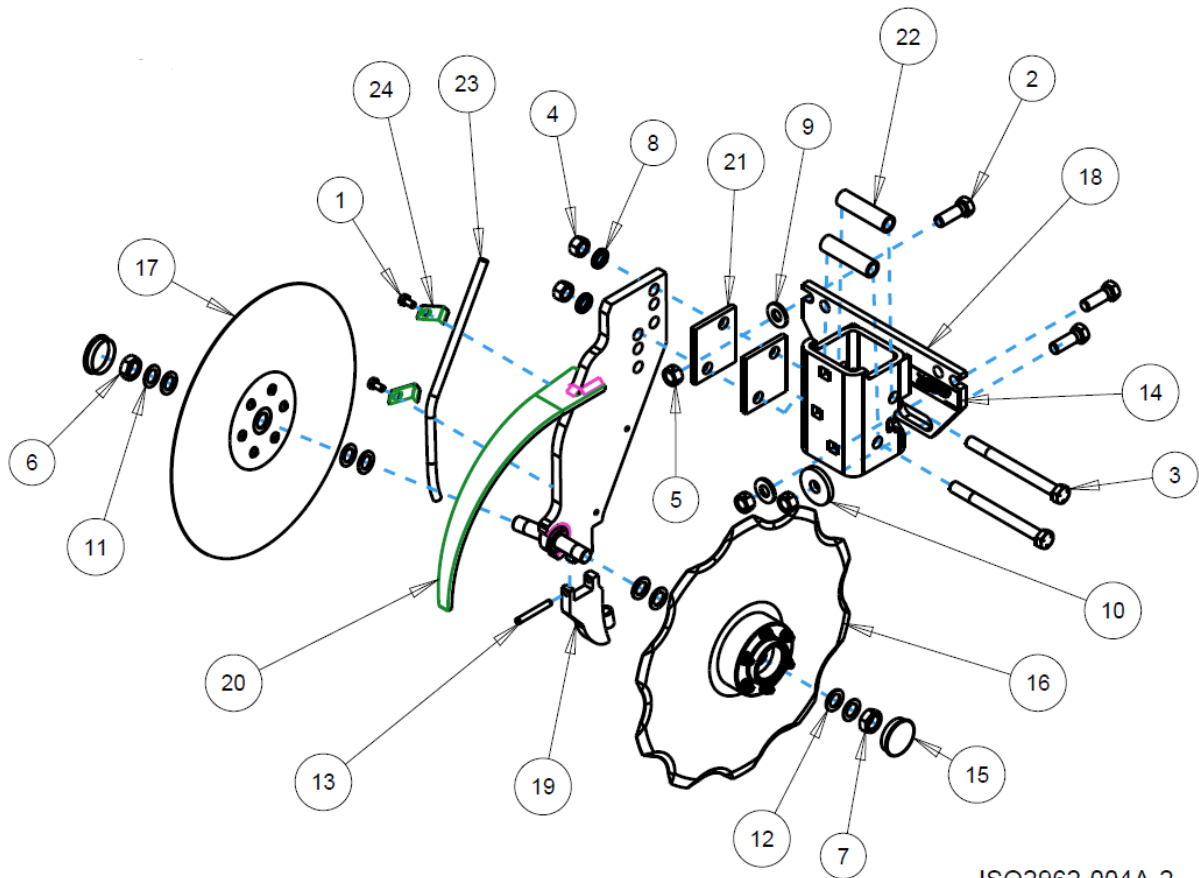

ISO2962-004A-2

ITEM	PART NO.	DESCRIPTION	QTY
1	2502-104	1/4-20 X 1/2 HHCS GR. 5 ZYD.	2
2	2502-294	1/2-13 X 1-1/2 HHCS GR5 ZP	3
3	2502-368	1/2-13 X 5-1/2 HHCS GR5 ZP	2
4	2520-352	1/2-13 HEX NUT ZP	2
5	2520-357	1/2-13 LOCK HEX NUT, GR A, ZP	3
6	2520-453	5/8-11 JAM HEX NUT ZP	1
7	2520-466	5/8-11 L.H. JAM HEX NUT ZP	1
8	2525-352	1/2 MED LOCKWASHER ZP.	2
9	2526-355	1/2 FLAT WASHER HARD'ND ZP	2
10	2526-402	9/16ID X 1-3/4 OD X 1/4MBZP	1
11	2527-562	5/8ID X 1OD X .049+-.002M BU ZP	4
12	2527-563	5/8ID X 1"OD X 14GA MACH BU	4
13	2530-153	1/4 X 2 ROLL PIN ZP	1
14	2565-179	YETTER DECAL 1" X 3"	1
15	2570-543	HUB CAP, HARTFORD #10802	2
16	2962-129	NOTCHED BLADE ASSEMBLY (2016)	1
17	2962-130	SMOOTH BLADE ASSEMBLY (2016)	1
18	2962-206	MOUNT W.A. UMDDFO (2010)	1
19	2962-218	INTERNAL SCRAPER W.A. (2015)	1
20	2962-220	ARM W.A.(RH) UMDDFO (2016)	1
21	2962-302	.25" SPACER, RUMDDFO	2
22	2962-322	BUSHING	2
23	2962-334	LIQUID TUBE	1
24	2962-335	TUBE CLAMP	2

MFG 1/2017 TO PRESENT

PARTS IDENTIFICATION
2962-010A
RIGHT HAND GRANULAR ASSEMBLY

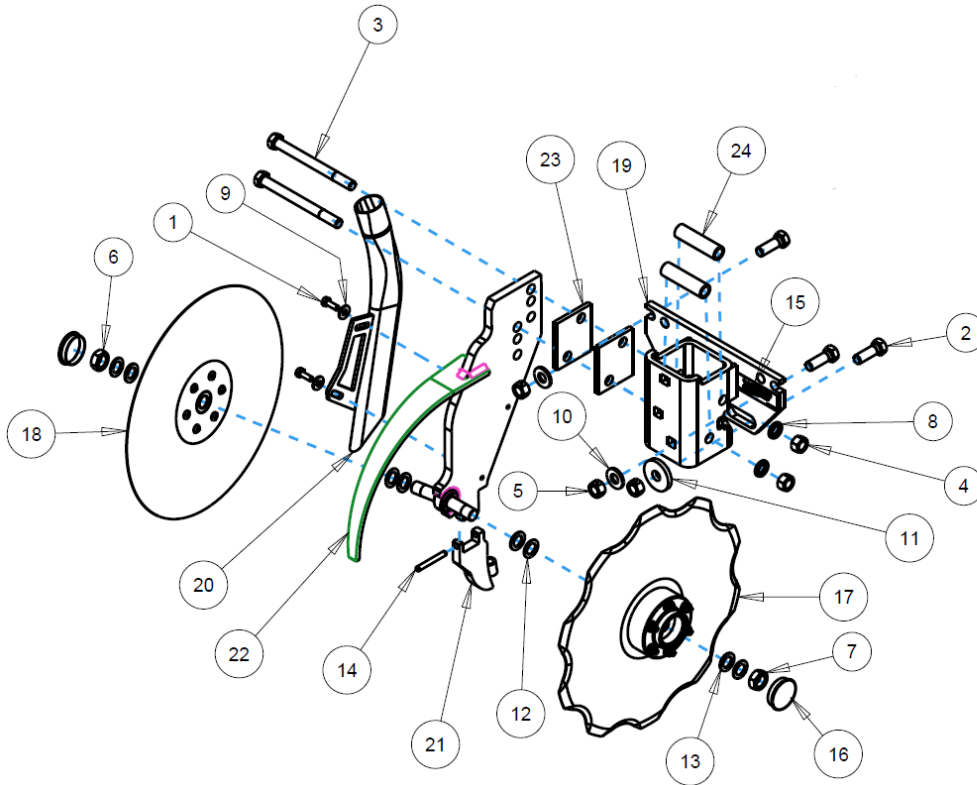

ITEM	PART NO.	DESCRIPTION	QTY
1	2502-105	1/4-20 X 3/4 HHCS GR 5 ZP	2
2	2502-294	1/2-13 X 1-1/2 HHCS GR5 ZP	3
3	2502-368	1/2-13 X 5-1/2 HHCS GR5 ZP	2
4	2520-352	1/2-13 HEX NUT ZP	2
5	2520-357	1/2-13 LOCK HEX NUT, GR A, ZP	3
6	2520-453	5/8-11 JAM HEX NUT ZP	1
7	2520-466	5/8-11 L.H. JAM HEX NUT ZP	1
8	2525-352	1/2 MED LOCKWASHER ZP.	2
9	2526-151	1/4 STD FLATWASHER ZP	2
10	2526-355	1/2 FLAT WASHER HARD'ND ZP	2
11	2526-402	9/16ID X 1-3/4 OD X 1/4MBZP	1
12	2527-562	5/8ID X 1OD X .049+- .002M BU ZP	4
13	2527-563	5/8ID X 1"OD X 14GA MACH BU	4
14	2530-153	1/4 X 2 ROLL PIN ZP	1
15	2565-179	YETTER DECAL 1" X 3"	1
16	2570-543	HUB CAP, HARTFORD #10802	2
17	2962-129	NOTCHED BLADE ASSEMBLY (2016)	1
18	2962-130	SMOOTH BLADE ASSEMBLY (2016)	1
19	2962-206	MOUNT W.A. UMDDFO (2010)	1
20	2962-216	DRY TUBE W.A., RH	1
21	2962-218	INTERNAL SCRAPER W.A. (2015)	1
22	2962-220	ARM W.A.(RH) UMDDFO (2016)	1
23	2962-302	.25" SPACER, RUMDDFO	2
24	2962-322	BUSHING	2

MFG 1/2017 TO PRESENT

PARTS IDENTIFICATION
2962-011A
LEFT HAND GRANULAR ASSEMBLY

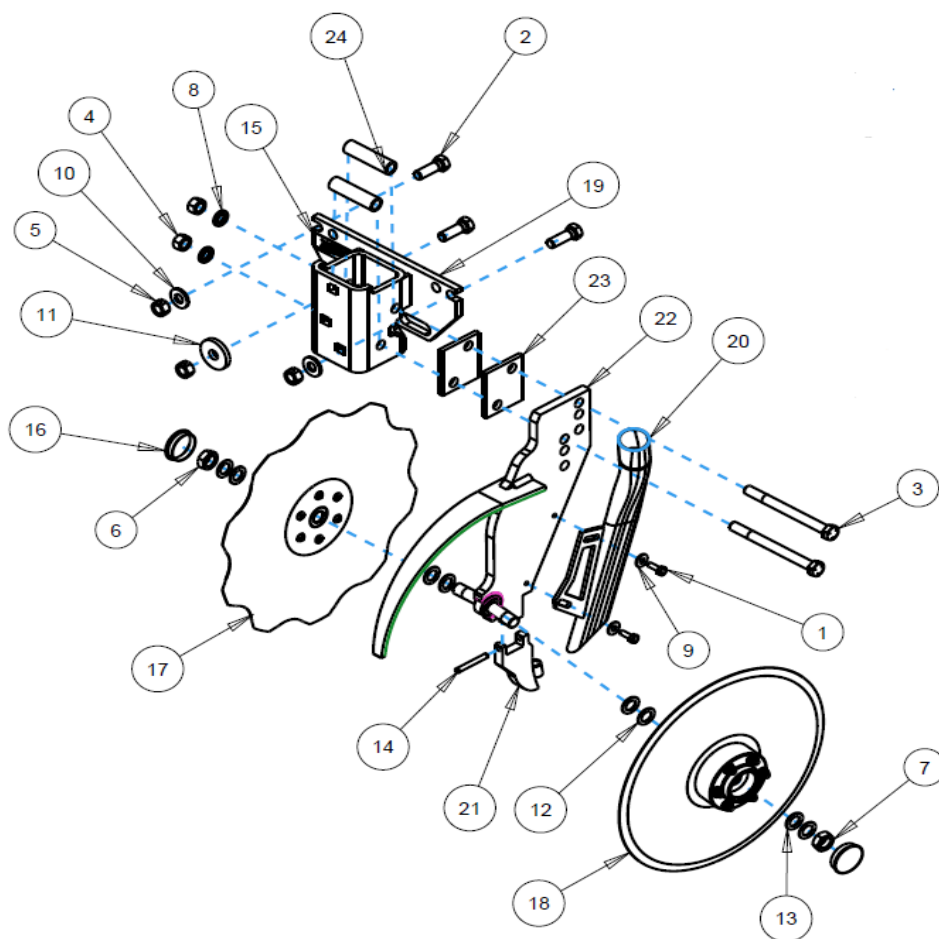

ITEM	PART NO.	DESCRIPTION	QTY
1	2502-105	1/4-20 X 3/4 HHCS GR 5 ZP	2
2	2502-294	1/2-13 X 1-1/2 HHCS GR5 ZP	3
3	2502-368	1/2-13 X 5-1/2 HHCS GR5 ZP	2
4	2520-352	1/2-13 HEX NUT ZP	2
5	2520-357	1/2-13 LOCK HEX NUT, GR A, ZP	3
6	2520-453	5/8-11 JAM HEX NUT ZP	1
7	2520-466	5/8-11 L.H. JAM HEX NUT ZP	1
8	2525-352	1/2 MED LOCKWASHER ZP.	2
9	2526-151	1/4 STD FLATWASHER ZP	2
10	2526-355	1/2 FLAT WASHER HARD'ND ZP	2
11	2526-402	9/16ID X 1-3/4 OD X 1/4MBZP	1
12	2527-562	5/8ID X 1OD X .049+-.002M BU ZP	4
13	2527-563	5/8ID X 1"OD X 14GA MACH BU	4
14	2530-153	1/4 X 2 ROLL PIN ZP	1
15	2565-179	YETTER DECAL 1" X 3"	1
16	2570-543	HUB CAP, HARTFORD #10802	2
17	2962-129	NOTCHED BLADE ASSEMBLY (2016)	1
18	2962-130	SMOOTH BLADE ASSEMBLY (2016)	1
19	2962-206	MOUNT W.A. UMDDFO (2010)	1
20	2962-215	DRY TUBE W.A. LH	1
21	2962-218	INTERNAL SCRAPER W.A. (2015)	1
22	2962-221	ARM W.A.(LH) UMDDFO (2016)	1
23	2962-302	.25" SPACER, RUMDDFO	2
24	2962-322	BUSHING	2

MFG 1/2017 TO PRESENT

PARTS IDENTIFICATION

2962-135

RH LIQUID ASSEMBLY

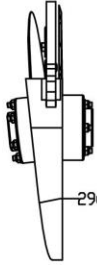

2962-220 COULTER ARM W.A., RH

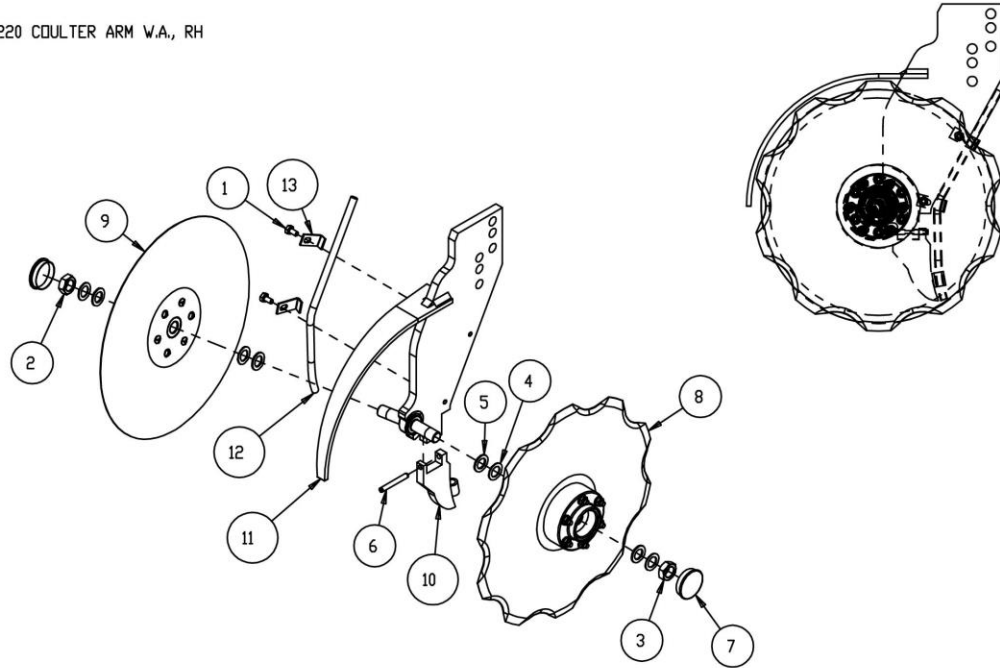

ITEM	PART NO.	DESCRIPTION	QTY
1	2502-104	1/4-20 X 1/2 HHCS GR. 5 ZYD.	2
2	2520-453	5/8-11 JAM HEX NUT ZP	1
3	2520-466	5/8-11 L.H. JAM HEX NUT ZP	1
4	2527-562	5/8IDX1ODX.049+-002M BU ZP	4
5	2527-563	5/8ID X1"OD X14GA MACH BU	4
6	2530-153	1/4 X 2 ROLL PIN ZP	1
7	2570-543	HUB CAP, HARTFORD #10802	2
8	2962-129	NOTCHED BLADE ASSEMBLY (2016)	1
9	2962-130	SMOOTH BLADE ASSEMBLY (2016)	1
10	2962-218	INTERNAL SCRAPER W.A. (2015)	1
11	2962-220	ARM W.A.(RH) UMDDFD (2016)	1
12	2962-334	LIQUID TUBE	1
13	2962-335	TUBE CLAMP	2

MFG 1/2017 TO PRESENT

PARTS IDENTIFICATION

2962-136

LH LIQUID ASSEMBLY

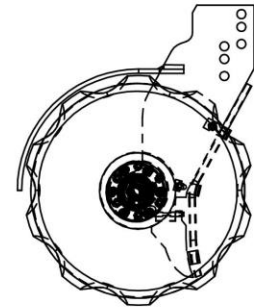
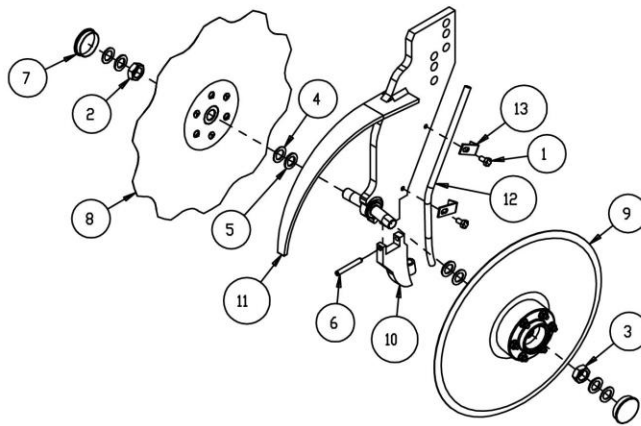
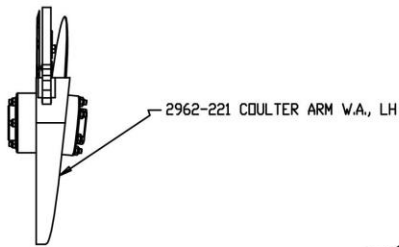

ITEM	PART NO.	DESCRIPTION	QTY
1	2502-104	1/4-20 X 1/2 HHCS GR. 5 ZYD.	2
2	2520-453	5/8-11 JAM HEX NUT ZP	1
3	2520-466	5/8-11 L.H. JAM HEX NUT ZP	1
4	2527-562	5/8IDX10DX.049+-002M BU ZP	4
5	2527-563	5/8ID X1"OD X14GA MACH BU	4
6	2530-153	1/4 X 2 ROLL PIN ZP	1
7	2570-543	HUB CAP, HARTFORD #10802	2
8	2962-129	NOTCHED BLADE ASSEMBLY (2016)	1
9	2962-130	SMOOTH BLADE ASSEMBLY (2016)	1
10	2962-218	INTERNAL SCRAPER W.A. (2015)	1
11	2962-221	ARM W.A.(LH) UMDDFD (2016)	1
12	2962-334	LIQUID TUBE	1
13	2962-335	TUBE CLAMP	2

MFG 1/2017 TO PRESENT

PARTS IDENTIFICATION
2962-137
RH GRANULAR ASSEMBLY

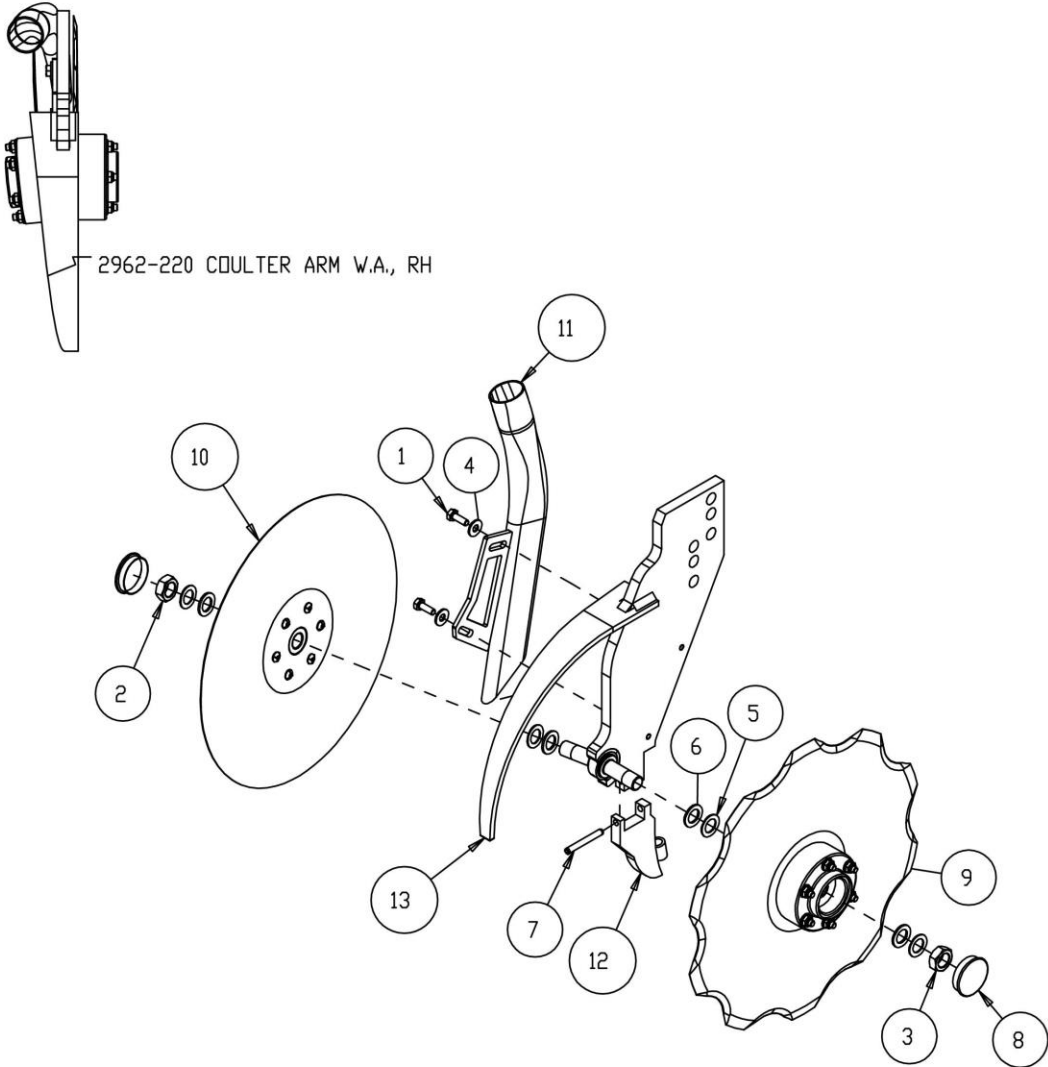

ITEM	PART NO.	DESCRIPTION	QTY
1	2502-105	1/4-20 X 3/4 HHCS GR 5 ZP	2
2	2520-453	5/8-11 JAM HEX NUT ZP	1
3	2520-466	5/8-11 L.H. JAM HEX NUT ZP	1
4	2526-151	1/4 STD FLATWASHER ZP	2
5	2527-562	5/8ID X 1.00 X .049+- .002M BU ZP	4
6	2527-563	5/8ID X 1.00 X .049+- .002M BU	4
7	2530-153	1/4 X 2 ROLL PIN ZP	1
8	2570-543	HUB CAP, HARTFORD #10802	2
9	2962-129	NOTCHED BLADE ASSEMBLY (2016)	1
10	2962-130	SMOOTH BLADE ASSEMBLY (2016)	1
11	2962-216	DRY TUBE W.A., RH	1
12	2962-218	INTERNAL SCRAPER W.A. (2015)	1
13	2962-220	ARM W.A.(RH) UMDDFD (2016)	1

MFG 1/2017 TO PRESENT

PARTS IDENTIFICATION
2962-138
LH GRANULAR ASSEMBLY

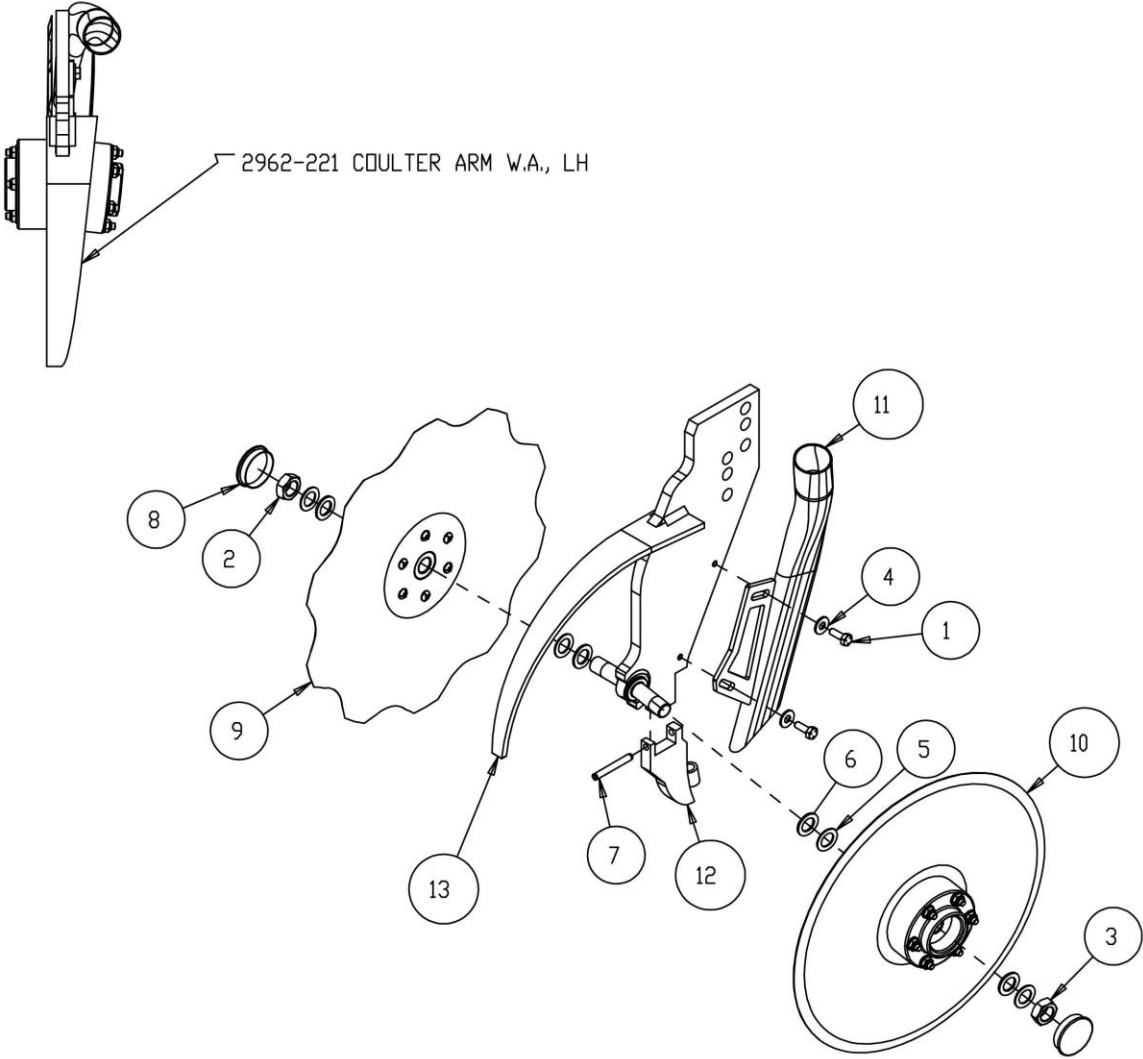

ITEM	PART NO.	DESCRIPTION	QTY
1	2502-105	1/4-20 X 3/4 HHCS GR 5 ZP	2
2	2520-453	5/8-11 JAM HEX NUT ZP	1
3	2520-466	5/8-11 L.H. JAM HEX NUT ZP	1
4	2526-151	1/4 STD FLATWASHER ZP	2
5	2527-562	5/8IDX1DDX.049+-,002M BU ZP	4
6	2527-563	5/8ID X1*DD X14GA MACH BU	4
7	2530-153	1/4 X 2 ROLL PIN ZP	1
8	2570-543	HUB CAP, HARTFORD #10802	2
9	2962-129	NOTCHED BLADE ASSEMBLY (2016)	1
10	2962-130	SMOOTH BLADE ASSEMBLY (2016)	1
11	2962-215	DRY TUBE W.A. LH	1
12	2962-218	INTERNAL SCRAPER W.A. (2015)	1
13	2962-221	ARM W.A.(LH) UMDDFD (2016)	1

MFG 1/2017 TO PRESENT

PARTS IDENTIFICATION

2962-129

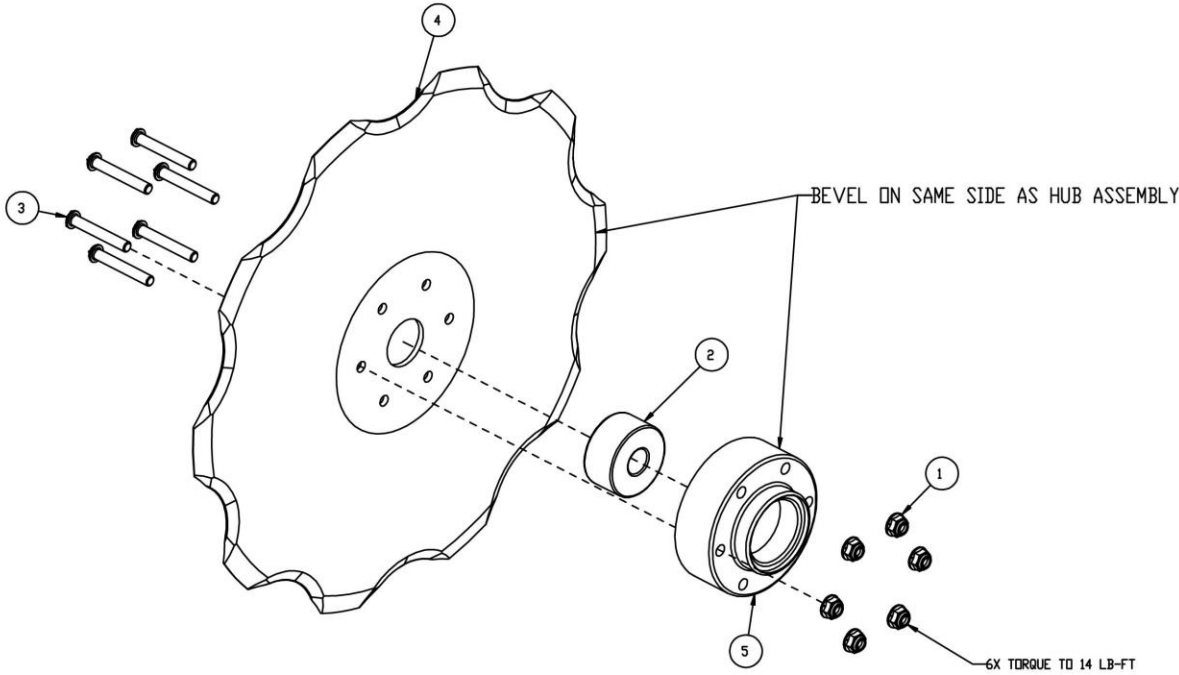

ITEM	PART NO.	DESCRIPTION	QTY
1	2520-159	1/4-20 HEX FLANGE NYLON INSERT NUT, GR F	6
2	2550-336	DOUBLE ROW BEARING	1
3	2570-205	1/4-20 x 1.75" BHSCS, GR 5, ZP	6
4	2571-283	.138 X 13.5 NOTCHED BLADE	1
5	2962-346	DOUBLE DISC HUB (2016)	1

MFG 1/2017 TO PRESENT

PARTS IDENTIFICATION

2962-130

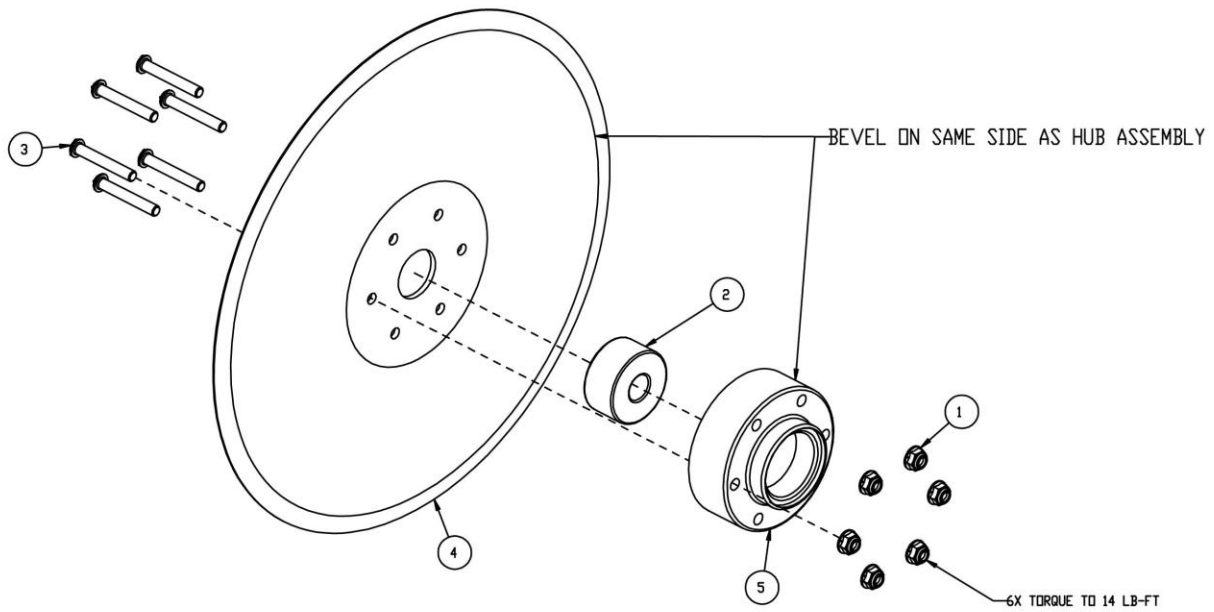

ITEM	PART NO.	DESCRIPTION	QTY
1	2520-159	1/4-20 HEX FLANGE NYLON INSERT NUT, GR F	6
2	2550-336	DOUBLE ROW BEARING	1
3	2570-205	1/4-20 x 1.75" BHSCS, GR 5, ZP	6
4	2571-284	.138 X 12.5 OPENER BLADE	1
5	2962-346	DOUBLE DISC HUB (2016)	1

MFG 1/2017 TO PRESENT

PARTS IDENTIFICATION

2962-114, UMDDFO RM ARM ASS'Y

DET	QTY	PART NO.	DESCRIPTION
1	1	2962-210	EXTENSION TUBE W.A.
2	1	2502-104	1/4-20 X 1/2 HHCS GR. 5 ZYD.
3	1	2520-152	1/4-20 LOCK HEX NUT ZP
4	1	2967-764	ACME SCREW, TWIN ROW
5	1	2962-211	UMDDFO RESIDUE MANAGER ARM
6	1	2533-110	1/4-28 ZERK STRAIGHT SELF-TAP
7	3	2510-102	#10-32X.25HSHCPS ZP W/TRDLCK
8	1	2967-652	DETENT PLATE
9	1	2967-699	ADJUSTMENT KNOB (9/07)
10	1	2530-157	1/4 X 1-3/4 ROLL PIN ZP
11	2	2526-453	5/8 SAE FLATWASHER ZP

1798-4

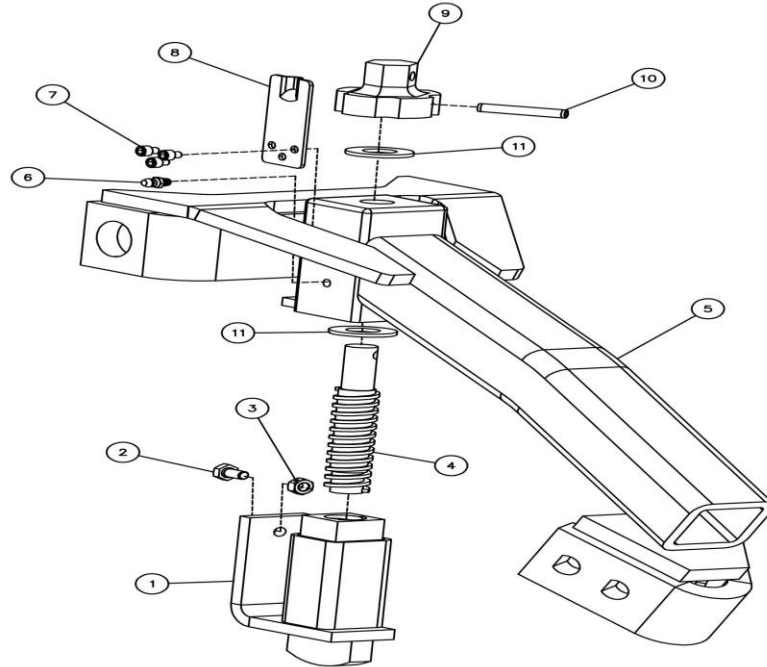

8 BOLT HUB ASSEMBLY

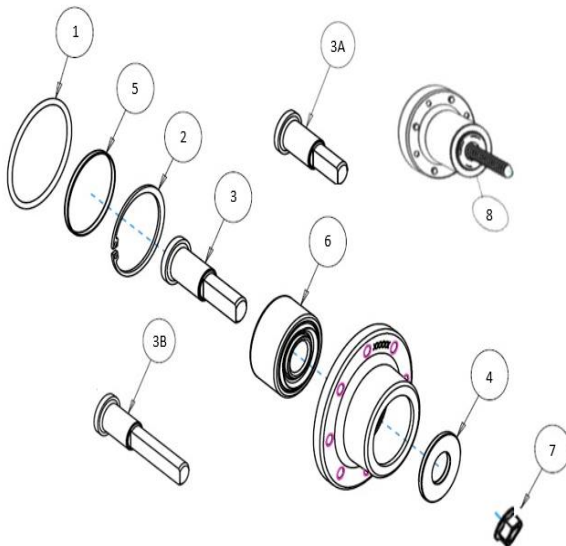

ITEM	PART #	DESCRIPTION	QTY
1	2550-074	O-RING 3.55MM X 56MM ID	1
2	2550-529	SNAP RING	1
3	2965-600A	SHAFT 73 MM (2965-500A HUB ASSEMBLY)	1
3A	2965-602A	SHAFT 66.7 MM (2965-502A HUB ASSEMBLY)	1
3B	2965-601A	SHAFT 98.4 MM (2965-501A HUB ASSEMBLY)	1
4	2965-604A	SPACER	1
5	2965-605A	CAP	1
6	2965-606	BEARING	1
7	2520-465	5/8-11 FLANGE HEX NUT GRADE 8	1
8	2965-500A	HUB ASSEMBLY 1.406" SPINDLE	1
	2965-501A	HUB ASSEMBLY 2.406" SPINDLE	1
	2965-502A	HUB ASSEMBLY 1.157" SPINDLE	1

PARTS IDENTIFICATION

2962-005B-ST-FW RESIDUE MANAGER

ITEM	PART NO.	DESCRIPTION	QTY
1	2502-220	5/16-18 X 3/4 HHFS GR5 ZP	4
2	2502-221	5/16-18 X 1 HHFS GR5 ZP	4
3	2515-562	13" WHEEL COVER, BLACK	2
4	2571-286	SHARKTOOTH WHEEL, 8 BOLT	1
5	2965-500	HUB ASSEMBLY, 1.406 SPINDLE	1
6	2967-560	FLOATER WHEEL	1

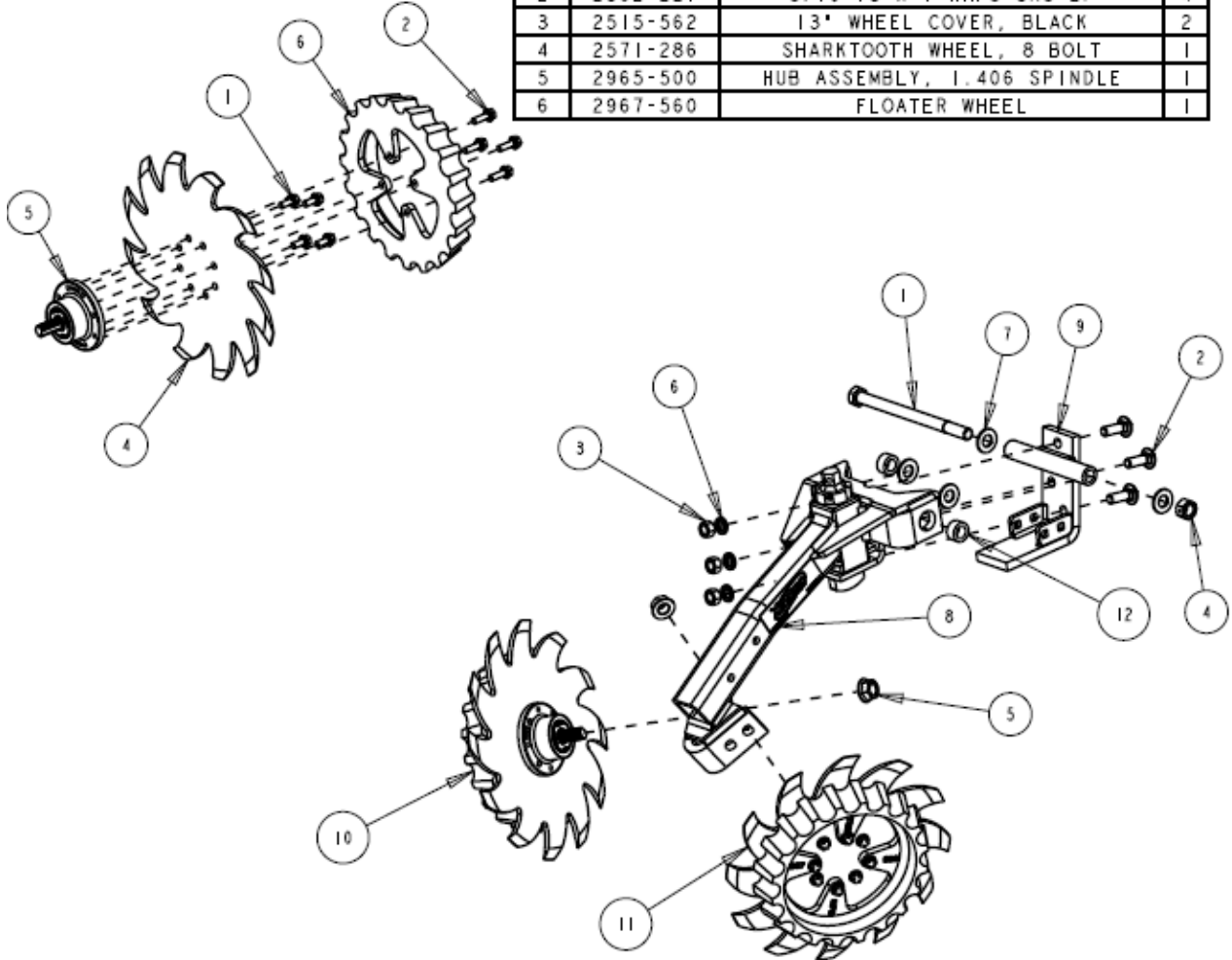

ITEM	PART NO.	DESCRIPTION	QTY
1	2502-333	5/8-11 X 9 HHCS GR. 5 ZP	1
2	2505-339	1/2-13 X 1-1/2 CARBLT G5ZP	3
3	2520-352	1/2-13 HEX NUT ZP	3
4	2520-459	5/8-11 LOCK HEX NUT, GR B, ZP	1
5	2520-465	5/8-11 SER. FLANGE NUT, GR 8, ZP	2
6	2525-352	1/2 MED LOCKWASHER ZP.	3
7	2526-454	5/8 SAE FLATWASHER HRD'ND ZP	4
8	2962-114	UMDDFO RESIDUE MANAGER ARM ASSY	1
9	2962-209	RM MOUNT BRKT.	1
10	2966-140-ST-FW	SHRKTH ASSY,RH,3"D-BOLT FLT WL	1
11	2966-141-ST-FW	SHRKTH ASSY,LH,3"D-BOLT FLT WL	1
12	2967-553	PIVOT BUSHING	2

PARTS IDENTIFICATION 2966-140-BW-FW

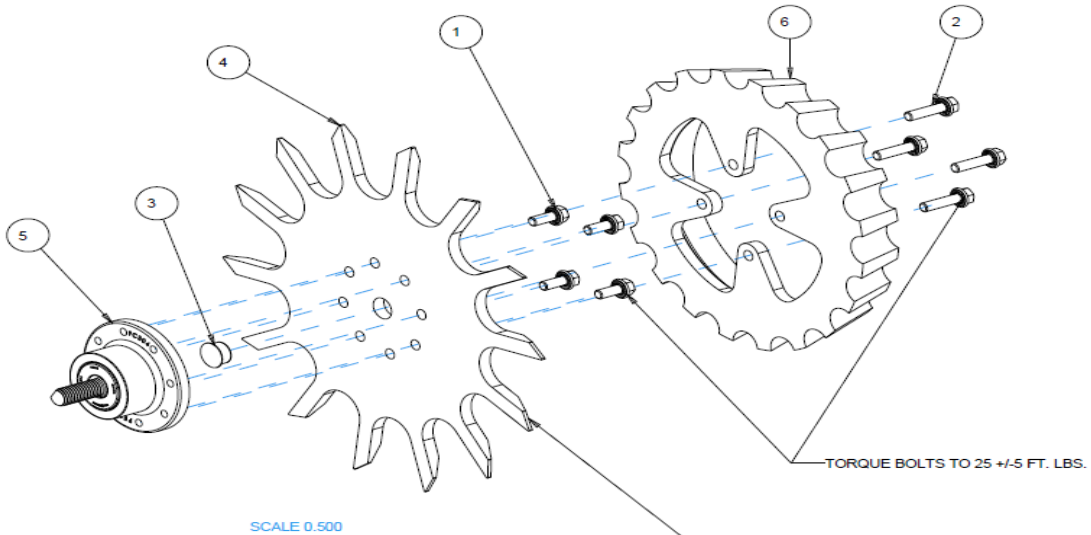

ORIENTATION OF WHEEL
DETERMINES RH ASSEMBLY
NOTE: BEVELS AWAY FROM HUB SIDE

ITEM	PART NO.	DESCRIPTION	QTY
1	2502-220	5/16-18 X 3/4 HHFS GR5 ZP	4
2	2502-222	5/16-18 X 1-1/4 HHFS GR5 ZP	4
3	2570-994	BEVEL WHEEL CENTER HOLE PLUG	1
4	2571-287-R	13" BEVEL WHEEL, 8 BOLT, RH	1
5	2965-500	HUB ASSEMBLY, 1.406 SPINDLE	1
6	2967-560	FLOATER WHEEL	1

2966-141-BW-FW

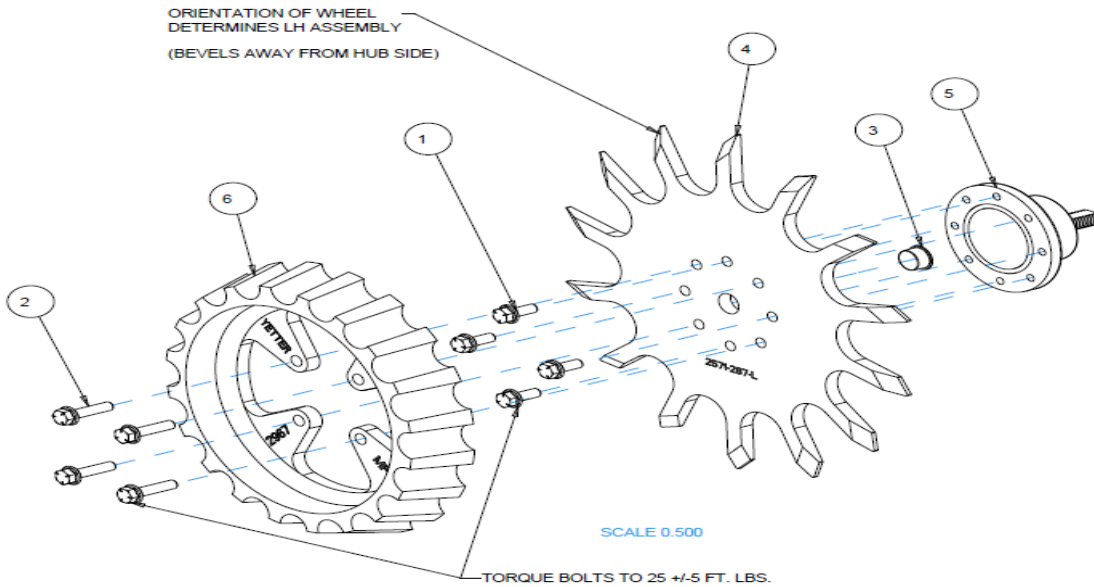

ORIENTATION OF WHEEL
DETERMINES LH ASSEMBLY
(BEVELS AWAY FROM HUB SIDE)

ITEM	PART NO.	DESCRIPTION	QTY
1	2502-220	5/16-18 X 3/4 HHFS GR5 ZP	4
2	2502-222	5/16-18 X 1-1/4 HHFS GR5 ZP	4
3	2570-994	BEVEL WHEEL CENTER HOLE PLUG	1
4	2571-287-L	13" BEVEL WHEEL, 8 BOLT, LH	1
5	2965-500	HUB ASSEMBLY, 1.406 SPINDLE	1
6	2967-560	FLOATER WHEEL	1

FIELD SERVICE KITS

- 2965-119 - SERVICE KIT FOR 2570-740-2.812 D-BOLT
- 2965-120 - SERVICE KIT FOR 2570-742-3.812 D-BOLT
- 2965-121 - SERVICE KIT FOR 2570-766-2.562 D-BOLT

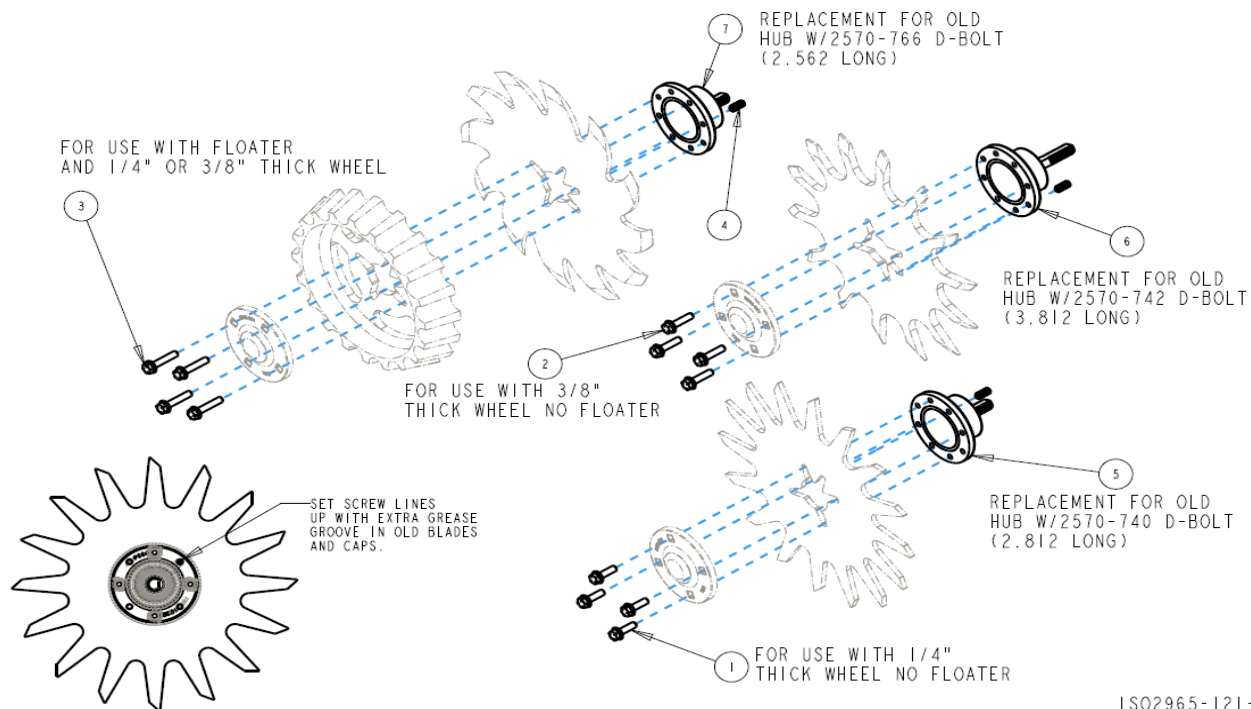

ISO2965-121-2

ITEM	PART NO	DESCRIPTION	QTY
1	2502-221	5/16-18 X 1 HHFS GRADE 5	4
2	2502-222	5/16-18 X 1-1/4 HHFS GRADE 5	4
3	2502-225	5/16-18 X 1-1/2 HHFS GRADE 5	4
4	2940-560	SET SCREW	1
5	2965-500	HUB ASSEMBLY 1.406 SPINDLE	1
6	2965-501	HUB ASSEMBLY 2.406 SPINDLE	1
7	2965-502	HUB ASSEMBLY 1.157 SPINDLE	1



ITEM	PART NO	DESCRIPTION	QTY
1	2505-207	5/16-18 X 1-1/4 CARRIAGE HEAD BOLT GRADE 5	4
2	2520-206	5/16-18 FLANGE LOCK NUT	4
3	2570-740	D-BOLT FLANGE HEAD 5/8-11 X 2.812 GRADE 8	1
4	2965-128	HUB/BEARING ASSEMBLY	1
	2550-069	SEAL	1
	2570-594	BEARING	1
	2570-715	INSERT	1
	2965-351	HUB	1
	2533-110	GREASE FITTING	1
5	2965-352	HUB CAP	1
6	2967-602	SHARK TOOTH WHEEL	1
7	2520-465	5/8-11 FLANGE LOCK NUT GRADE 8	1



A Tradition of Solutions since 1930

Yetter Farm Equipment Co

PO BOX 358 109 S. McDonough

Colchester, IL 62326-0358

Phone: 309-776-4111

Toll Free: 800-447-5777

Email: info@yetterco.com

For updated models and manuals visit the Yetter website:

www.yetterco.com

© Yetter Farm Equipment Co. All Rights Reserved

2565-954_REV_F . 06/2026