



TITAN™ SERIES
2960 U.N.T.™ COULTER
2967-007B U.N.T.™ RESIDUE MANAGER
OPERATOR'S MANUAL

2565-692_REV_V 06/2026



YETTER MANUFACTURING CO.
FOUNDED 1930

Colchester, IL 62326-0358
Toll free: 800/447-5777
309/776-3222 (Fax)
Website: www.yetterco.com
E-mail: info@yetterco.com

YETTER

FOREWORD

You've just joined an exclusive but rapidly growing club.

For our part, we want to welcome you to the group and thank you for buying a Yetter product.

We hope your new Yetter products will help you achieve both goals-increase your productivity and increase your efficiency so that you may generate more profit.

This operator's manual has been designed into four major sections: Foreword, Safety Precautions, Installation Instructions and Parts Breakdown.

This **SAFETY ALERT SYMBOL** indicates important safety messages in the manual. When you see this symbol, be alert to the possibility of **PERSONAL INJURY** and carefully read the message that follows.

 **DANGER:** Indicates an imminently hazardous situation which, if not avoided "will" result in death or serious injury. This signal word is to be limited to the most extreme situations

 **WARNING:** Indicates a potentially hazardous situation which, if not avoided, "could" result in death or serious injury.

 **CAUTION:** Indicates a potentially hazardous situation, which if not avoided, "may" result in minor or moderate injury. It may also be used to alert against unsafe practices.

 **NOTICE:** Indicates information considered important, but not hazard related (e.g., messages relating to property damage).

It is the responsibility of the user to read the operator's manual and comply with the safe and correct operating procedure and to lubricate and maintain the product according to the maintenance schedule in the operator's manual.

The user is responsible for inspecting his machine and for having parts repaired or replaced when continued use of the product would cause damage or excessive wear to the other parts.

It is the user's responsibility to deliver his machine to the Yetter dealer who sold him the product for service or replacement of defective parts, which are covered by the warranty policy.

If you are unable to understand or follow the instructions provided in this publication, consult your local Yetter dealer or contact:

YETTER MANUFACTURING CO.

309/776-4111

800/447-5777

309/776-3222 (FAX)

Website: www.yetterco.com

E-mail: info@yetterco.com

WARRANTY

Yetter Manufacturing warrants all products manufactured and sold by it against defects in material. This warranty being expressly limited to replacement at the factory of such parts or products as shall appear to be defective after inspection. This warranty does not obligate the Company to bear cost of labor in replacement of parts. It is the policy of the Company to make improvements without incurring obligations to add them to any unit already sold. No warranty is made or authorized to be made, other than herein set forth. This warranty is in effect for one year after purchase.

DEALER _____

Yetter Manufacturing warrants its own products only and cannot be responsible for damages to equipment on which mounted.



SAFETY PRECAUTIONS



A brief description of signal words that may be used in this manual:

DANGER: Indicates an imminently hazardous situation which, if not avoided “will” result in death or serious injury. This signal word is to be limited to the most extreme situations.

WARNING: Indicates a potentially hazardous situation which, if not avoided, “could” result in death or serious injury.

CAUTION: Indicates a potentially hazardous situation, which if not avoided, “may” result in minor or moderate injury. It may also be used to alert against unsafe practices.

NOTICE: Indicates information considered important, but not hazard related (e.g., messages relating to property damage).

Consult your implement and tractor operator’s manual for correct and safe operating practices. Be aware of towed implement width and allow safe clearance.

Safety decals are placed on the implement to alert the operator and others to the risk of personal injury or unsafe operation during normal operations and servicing.

1. The safety decals must be kept clean and in good condition to ensure that they are legible.
2. Safety decals must be replaced if they are missing or illegible.
3. When components are replaced during repair or servicing, check that the new components include the necessary safety signs.
4. Replacement safety decals may be obtained from your local dealer.



WARNING

Read these instructions carefully to acquaint yourself with the Equipment. Working with unfamiliar equipment can lead to accidents.

Never park the equipment on a steep incline or leave the equipment running unattended.

Never clean, lubricate or adjust a machine that is in motion.

Always check that straps are secure.

Make sure latches are in pinned position when moving equipment.

Do not allow children to operate this equipment.

Do not allow riders on the equipment, trailer and/or pick-up.

Use speed and caution dictated by the terrain being traversed. Do not operate on any slope steep enough to cause tipping or loss of control.

Read and understand the operator’s manual and require all other persons who will operate the equipment to do the same.

If operating on public roadways, where legal, be certain all lighting is operating properly and observe all traffic laws.

Beware of increased stopping distances and control effort when operating with implements attached.

Be familiar with all controls and be prepared to stop equipment quickly in an emergency.

FAILURE TO HEED MAY RESULT IN PERSONAL INJURY OR DEATH.

INTRODUCTION

The 2960 U.N.T.™ Unit Mounted Conservation Coulters has been designed as a 'universal' fitment for several makes of planter units.

By using two different mounting plates, the one boxed unit will fit several planters. One of the faceplate mount brackets will fit the John Deere MaxEmerge 2, Plus and Pro planters. The other brackets will fit old style 7000 John Deere units, Kinze, White 6000, White 9000, and Yetter planter row units. Several different styles of blades are available for every tillage practice, every soil type, and every residue condition, so you can choose the one that's right for you.

TABLE OF CONTENTS

Foreword..... 2

Safety 2-3

Torque Specifications..... 5

Installation Instructions..... 6-11

Operation 12-13

Maintenance 12

Part Identification..... 14-24

Troubleshooting..... 25

Operating Precautions..... 26

Planter Height Adjustment 27

		BLADE CHOICE					
FACTOR		SMOOTH (S)	RIPPLE	BUBBLE	8 WAVE (W)	13 WAVE (SW)	25 WAVE (MW)
SIZE	14-5/8"				X		X
	16"	X	X	X	X	X	X
AGGRESSIVE	LOW	X	X				
	MEDIUM			X			
	HIGH				X	X	X
SPEED	SLOW			X			X
	NORMAL	X	X	X		X	X
	FAST	X	X		X		
SOIL	DRY	X	X	X	X	X	X
CONDITION	DAMP/STICKY	X	X				
	SANDY		X	X	X	X	X
	HEAVY		X	X	X	X	X

BOLT TORQUE

Before operating the Titan™ Residue Manager for the first time, check to be sure that all hardware is tight. Check all hardware again after approximately 50 hours of operation and at the beginning of each planting season.

All hardware used on the Titan™ Residue Manager is Grade 5 unless otherwise noted. Grade 5 cap screws are marked with three radial lines on the head. If hardware must be replaced, be sure to replace it with hardware of equal size, strength and thread type. Refer to the torque values chart when tightening hardware.

Important: Over tightening hardware can cause as much damage as when under tightening. Tightening hardware beyond the recommended range can reduce its shock load capacity.







NOTICE: The chart below is a guide for proper torque. Use it unless a specified torque is called out elsewhere in the manual.

Torque is the force you apply to the wrench handle or the cheater bar, times the length of the handle or bar.

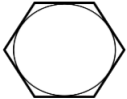
Use a torque wrench whenever possible.

The following table shows torque in ft. lbs. for coarse thread hardware.

Bolt Diameter and Threads per Inch	 Grade 2	 Grade 5	 A-325	 Grade 8
1/4	6	10	14	14
5/16	12	20	30	30
3/8 – 16	25	35	50	50
7/16 – 14	35	55	80	80
1/2 – 13	55	85	125	125
9/16 – 12	75	125	175	175
5/8 – 11	105	170	235	235
3/4-10	185	305	425	425
7/8 – 9	170	445	690	690
1-8	260	670	1030	1030
1 1/8 – 7	365	900	1460	1460
1 1/4 - 7	515	1275	2060	2060
1 3/8 – 6	675	1675	2700	2700
1 1/2 - 6	900	2150	3500	3500
1 3/4 – 5	1410	3500	5600	5600

Lubricate all bearings and moving parts as assembled and make certain that they work freely.



WARNING: Never work around the toolbar/implement while in a raised position without using safety lockups.



CAUTION: The Residue manager attachments are very heavy. Pay extra attention to lifting techniques while handling and or maneuvering the opener during assembly. Failure to do so may lead to personal injury.

INSTALLATION INSTRUCTIONS

		15" PLANTER BLADES			15" PLANTER BLADES
		JD 7000, KINZE, ALL WHITE 6000 AND 9000 PLANTERS			JD 1700, 7200, AND 7300 PLANTERS PRO AND PLUS SERIES
		BOLT POSITION #			BOLT POSITION #
	1	1-1/2" ABOVE	1		1" ABOVE
	2	1" ABOVE	2		5/8" ABOVE
16" COULTER BLADE	3	1/2" ABOVE	3		EVEN
	4	1/2" BELOW	4		7/8" BELOW

Note: This is a reference guide table – all measurements were taken with the row unit and planter frame level/parallel to the soil.

COULTER BLADE DEPTH ADJUSTMENT BOLT LOCATION

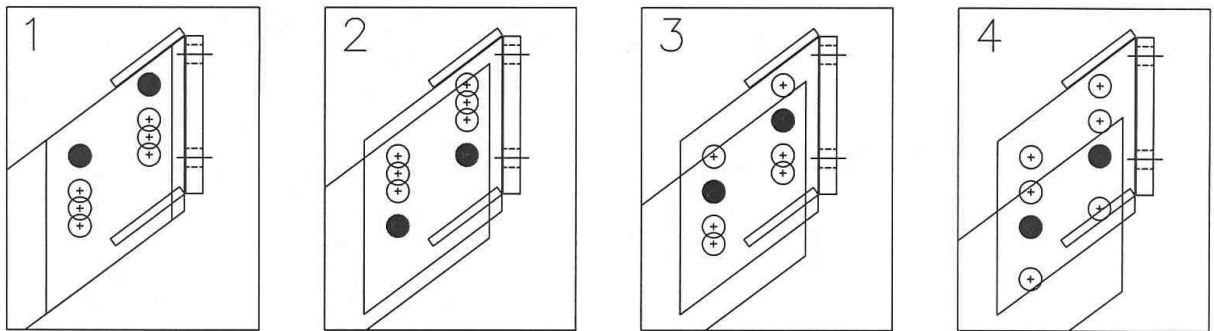

L505-2

Adjustment:

Adjust coultter blade depth equal to or above the planter opener blades. Adjust the blade depth as required for blade wear. Planter blades that are worn to 14 1/4" or smaller in diameter should be replaced. Example: 14 1/4" blades will have a 3/8" shallower planting depth than 15" blades at the same gauge wheel adjustment setting.

INSTALLATION INSTRUCTIONS

STEP 1. Attach the coultter bracket to the planter unit using (3) 1/2" x 1-1/2" bolts and lock nuts. Do not fully tighten hardware, coultter blade alignment to the planter opener will need to be done later.

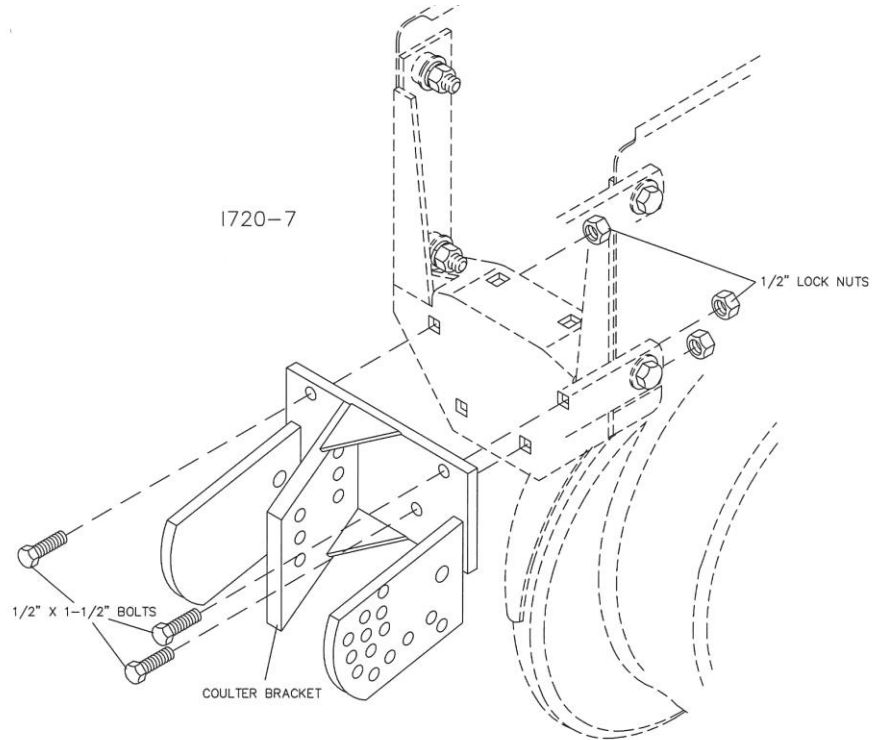

STEP 2. Attach the 2960-133 arm assembly to the coultter bracket using the 5/8" x 2" bolts, 1 5/8" flat washer and lock nuts. When the coultter is set to the desired depth, fully tighten the 5/8" x 2" bolts.

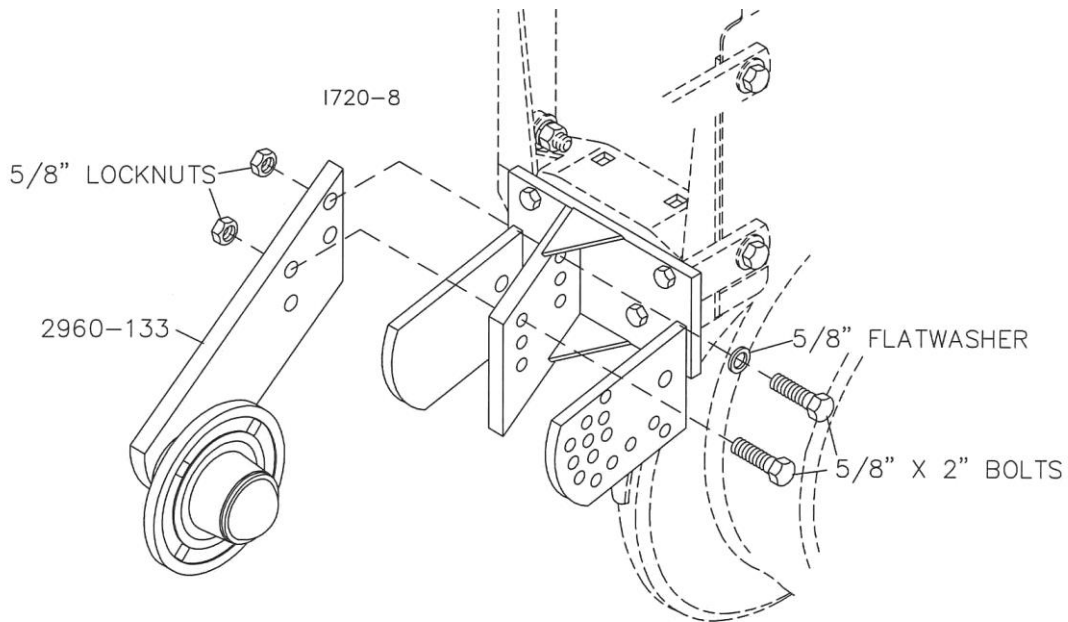

INSTALLATION INSTRUCTIONS



NOTICE: For models with residue managers go to **STEP 4**.

STEP 3. For coulters only models, Attach the blade to the coulters arm assembly using the 4) $\frac{1}{2}$ " x 1-1/2" carriage bolts, hex nuts, and lock washers. Fully tighten the carriage bolts. Torque to 85 ft/lbs.

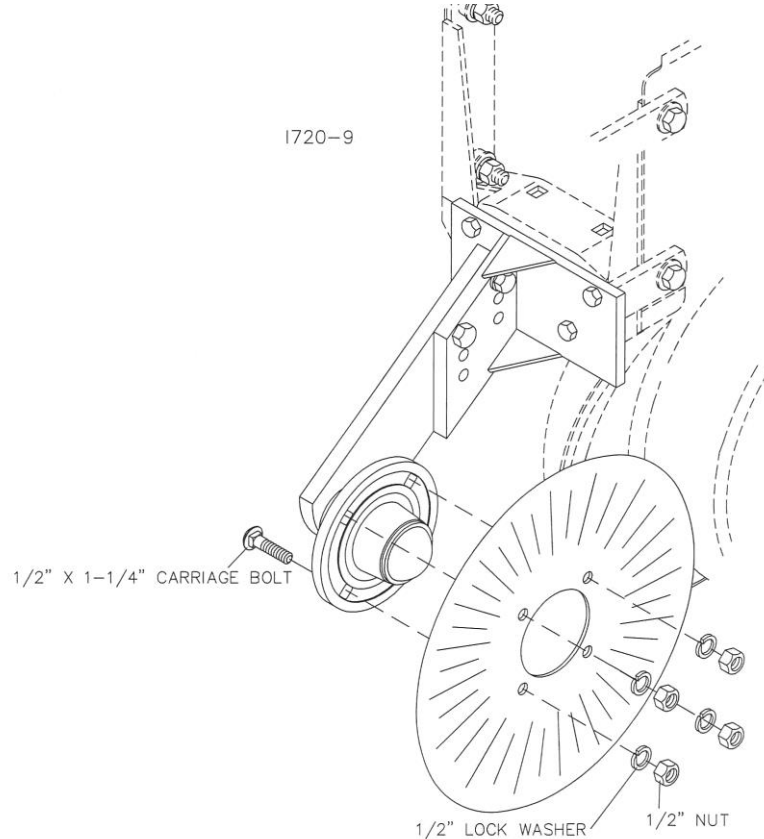

STEP 4. Align the coulters hub/blade to the planter row unit opener blades. Set the coulters blades to run perpendicular to the soil. Fully tighten the 3) $\frac{1}{2}$ " x 1-1/2" bolts on the coulters bracket to the planter row unit. Torque to 85 ft./lbs.

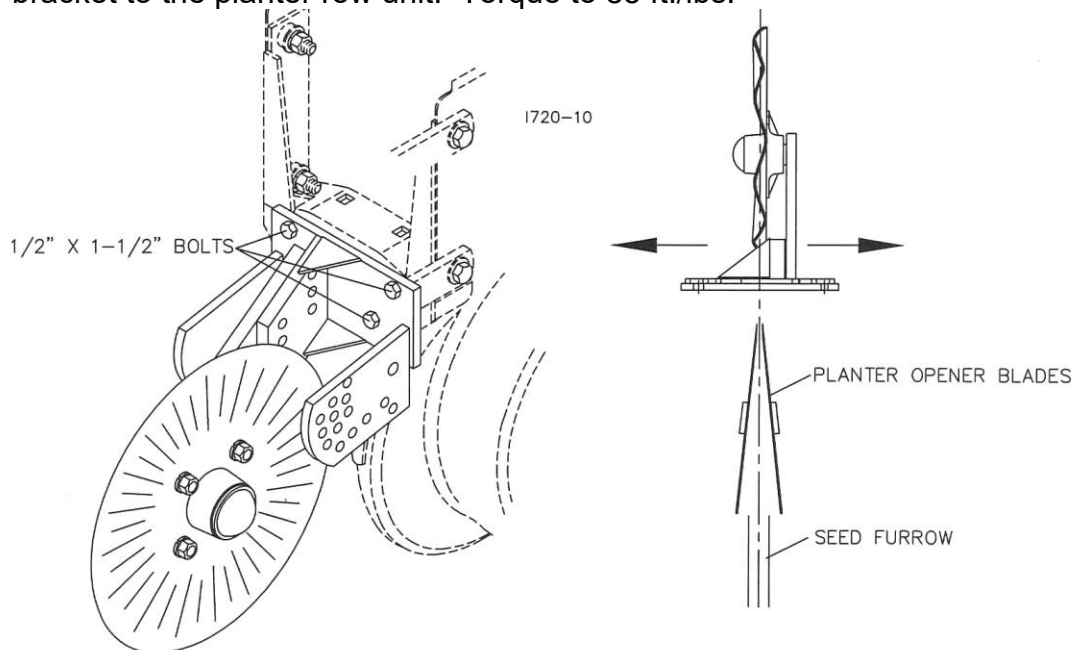

INSTALLATION INSTRUCTIONS

STEP 5. Attach the residue manager assembly to the coultter bracket using the 5/8" x 2-1/4" bolt, 6000-335 bushing, 2527-562 shim, 2960-401 adjustment support plate, 5/8 lock nut and the 1/2" x 2" bolt, 2967-622 spacer, 2527-562 shim and 1/2" locknut. Install the 2984-326 adjustment pin and 2570-448 hair pin cotter.

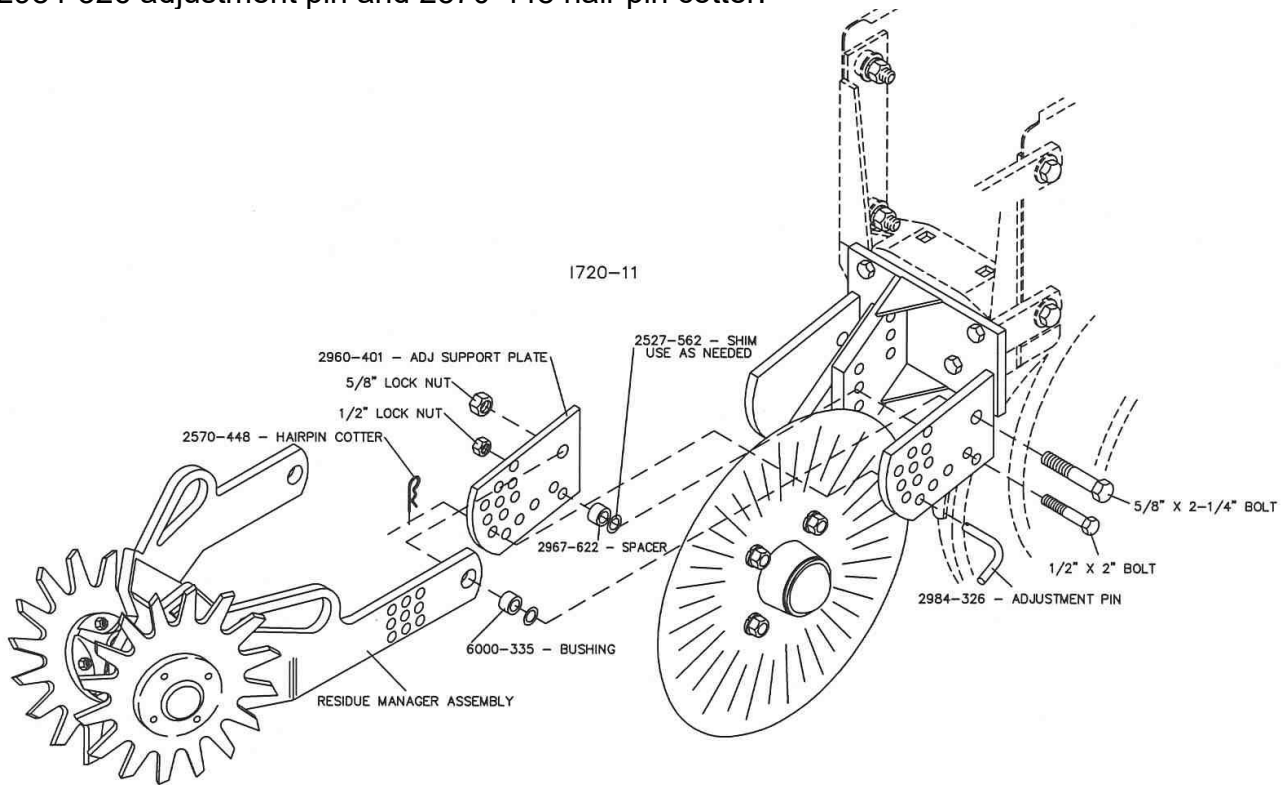

STEP 6. Install the 5/8" x 2-1/4" bolt, 2960-402 plate, 6000-335 bushing, 2527-562 shim, 5/8" lock nut and the 1/2" x 2" bolt, 2967-622 spacer, 2527-562 shim and 1/2" lock nut.

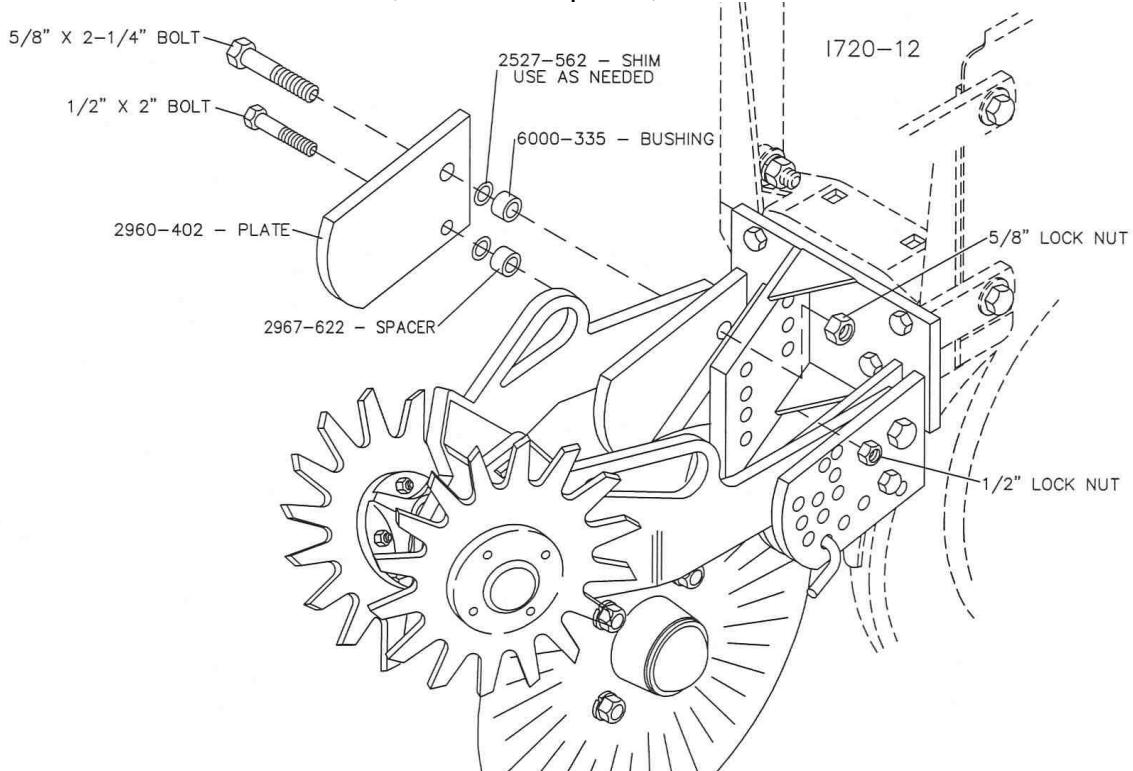

INSTALLATION INSTRUCTIONS

STEP 7. Attach the blade to the coultter arm assembly using the 4) 1/2" x 1-1/2" carriage bolts, lock washers and hex nuts. Torque to 85 ft./lbs.

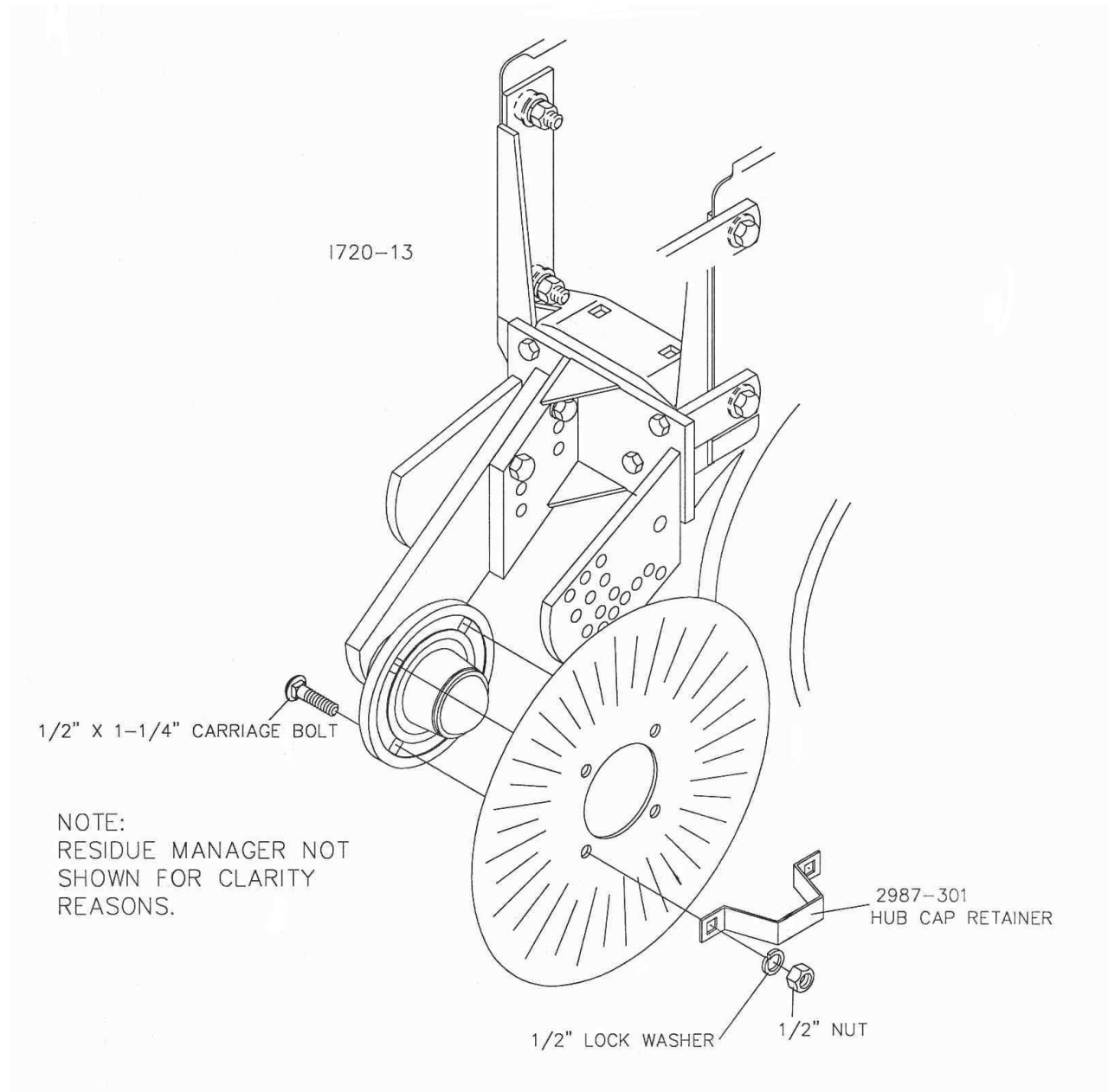

INSTALLATION INSTRUCTIONS

STEP 8. Choose the mounting hole in which to attach the residue manager wheels. Both wheels mounted in the front holes – wheels are interlocked. One wheel mounted in the front hole – wheels are offset. Both wheels mounted in the rear holes – wheels are spaced apart. **Torque 190 ft.lbs.**

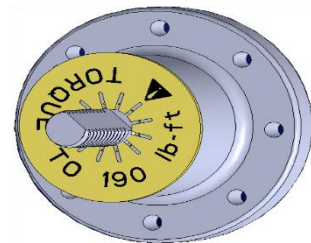
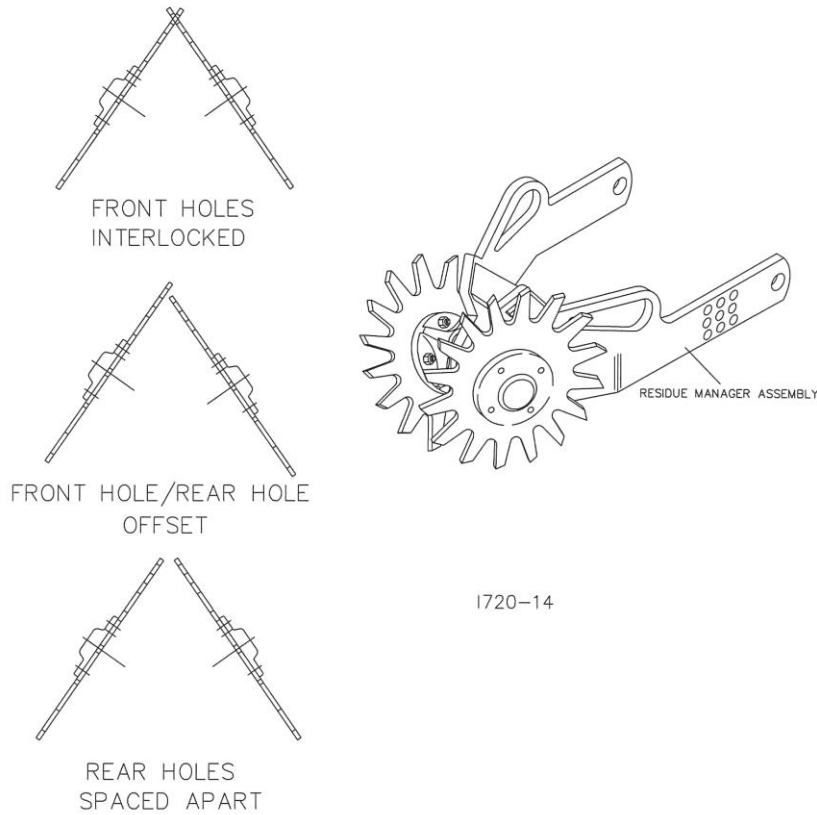

STEP 9. Check the alignment of the residue manager wheels, conservation coulters (if used) to the planter opener blades. Fully tighten mounting bolts. Torque to 85 ft./lbs.

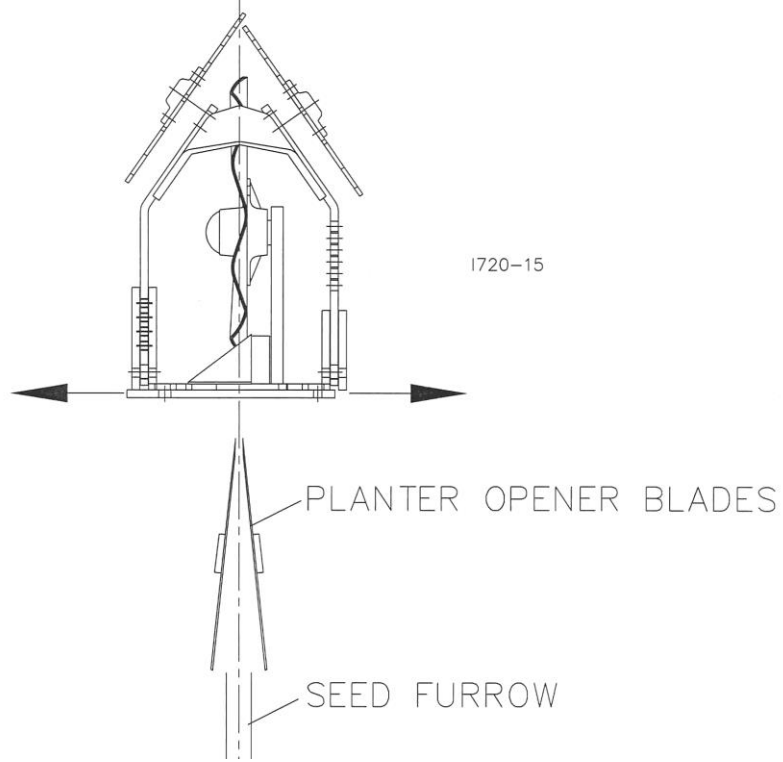

OPERATION

1. Set/mount coulter blades to run perpendicular to the soil. Operation depth and blade wear can be affected if the coulter is mounted crooked or if the toolbar is not level side to side.
2. After a few hours of use, check all bolts for tightness and proper torque.
3. After a day of use (10-12 hours) check coulter hubs for loose bearings. There should be no endplay in the hub bearings allowing the blade to wobble. If necessary, remove hubcap and cotter pin and adjust the slotted nut to remove wobble, recommended torque of 15 ft. lbs. and re-insert cotter pin. If the wobble or looseness cannot be corrected, the bearings, cups and seals will need to be replaced.
DO NOT USE WORN OR DAMAGED PARTS.

MAINTENANCE

LUBRICATION: USE #2 MULTI-PURPOSE POLYUREA GREASE

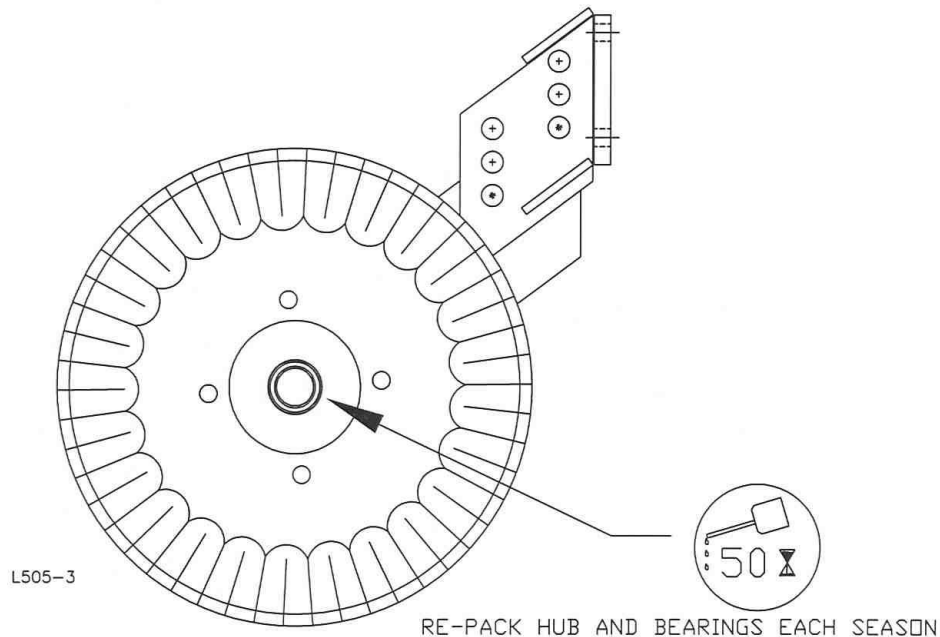

To ensure longevity and reliability of the U.N.T.[™] Coulter, the recommended lubrication schedule should be followed using multi-purpose grease at hourly intervals as indicated.

BEARING ADJUSTMENT:

1. Raise the toolbar until the blade is clear of the ground. Place a safety stand under the toolbar. Remove the hubcap, cotter pin, slotted nut and washer from the hub assembly. Remove the blade from the hub assembly.
2. Remove bearing cones and seals from hub.
3. Wash the old grease from the hub, bearing cups, spindle spacers, seals and bearing cones. Inspect the condition of the bearing cups, cones and seals. Replace if necessary.
4. Apply #2 multi-purpose polyurea grease on each bearing. Make sure the space around each roller is filled. Lubricate the bearing cups.
5. Position the bearing in the cup and install the seal. Lubricate the seal lips and proceed with re-assembly of the removed parts including the blade. Blade bolt torque is 90 to 96 ft. lbs.
6. Tighten the slotted nut to 15 ft. lbs. or until a definite drag is felt when the blade is turned by hand. Tighten the nut one slot position to line up the cotter pin hole with a slot. Secure the nut with a new cotter pin, replace hubcap.

OPERATION



NOTICE: Where rocks are present the residue manager should be set in the “float” position, not locked down.

Adjust the residue manager to move crop residue aside and not move any soil. Adjustments to the residue manager may have to be made when changing field conditions and type and amount of residue.

- Float setting – install the adjustment pin under the residue manager arm.
- Rigid setting – install the adjustment pin through the residue arm.

ROW CLEANER DO'S AND DON'TS

1. **DO NOT** move soil; Residue Managers are designed to move crop residue only.
2. **DO NOT** operate planter at slow speeds, ground speed affects how aggressive the spoke wheels are; operate at sufficient speed (4-6 mph) to maintain good residue flow.
3. **DO NOT** expect 100% of crop residue to be cleared, it is not necessary and would necessitate engaging the soil. The width of path cleared depends on ground conditions, depth setting and ground speed.
4. **DO** expect to see wheels occasionally quit turning, indicates ideal (shallow) setting which is not moving soil.
5. **DO** adjust toolbar frame height 20”-22” and drawbar correctly. Very important to ensure planter opener will follow ground contours properly.



NOTICE: For proper operation, the planter frame must operate level (for, aft and side to side) and at the correct height, typically 20”-22”. Regularly inspect the residue manager for loose or worn bolts. Repair and replace as needed.

PART IDENTIFICATION

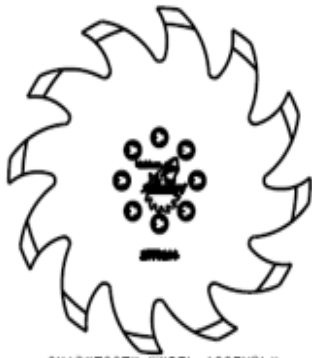

SHARKTOOTH WHEEL ASSEMBLY
RIGHT HAND 2966-140-ST(SHOWN)
LEFT HAND 2966-141-ST



SHARKTOOTH WHEEL ASSEMBLY W/FLOATER WHEEL
RIGHT HAND 2966-140-ST-FW(SHOWN)
LEFT HAND 2966-141-ST-FW



SHARKTOOTH WHEEL ASS'Y W/POLY FLOATER WHEEL
RIGHT HAND 2966-140-ST-PFW(SHOWN)
LEFT HAND 2966-141-ST-PFW

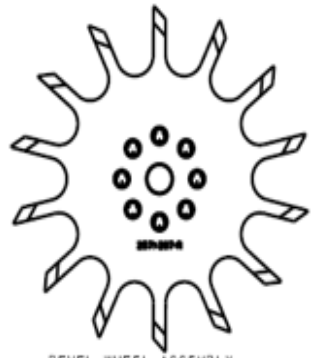

BEVEL WHEEL ASSEMBLY
RIGHT HAND 2966-140-BW(SHOWN)
LEFT HAND 2966-141-BW



BEVEL WHEEL ASSEMBLY W/FLOATER WHEEL
RIGHT HAND 2966-140-BW-FW(SHOWN)
LEFT HAND 2966-141-BW-FW

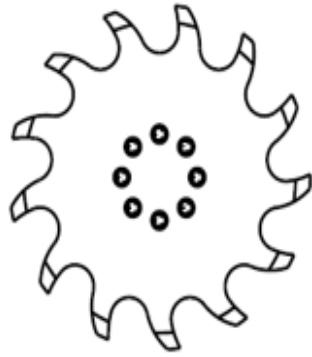

SHARKTOOTH FINGER WHEEL ASSEMBLY
RIGHT HAND 2966-140-STF(SHOWN)
LEFT HAND 2966-141-STF

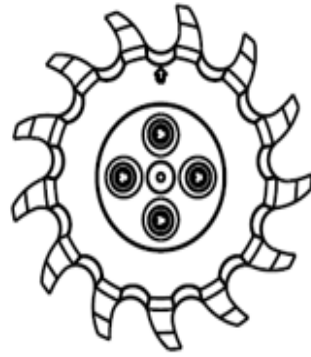

SHARKTOOTH FINGER WHEEL ASSEMBLY W/FLOATER WHEEL
RIGHT HAND 2966-140-STF-FW(SHOWN)
LEFT HAND 2966-141-STF-FW

ISO2966-140_ASSEMBLIES

PART IDENTIFICATION UNIVERSAL UNIT COULTER/TITAN MOUNT

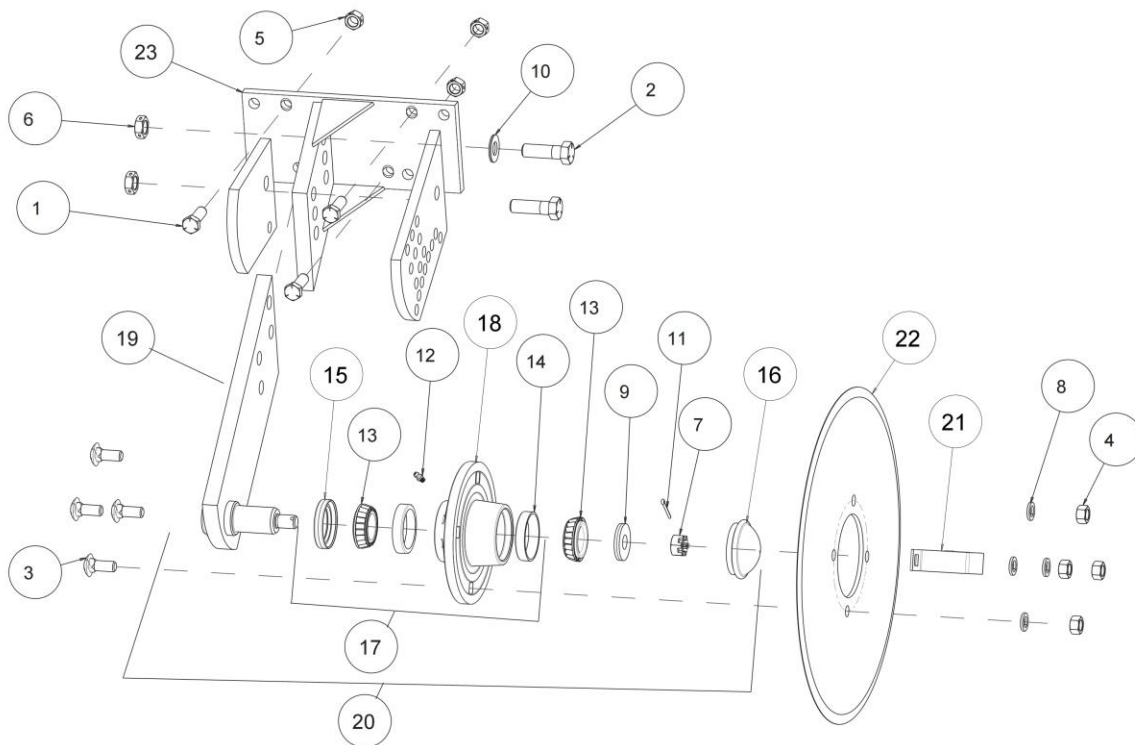

ITEM	PART #	DESCRIPTION	QTY
1	2502-294	½-13 X 1-1/2 CAP SCREW GRADE 5	3
2	2502-391	5/8-11 X 2 CAP SCREW GRADE 5	2
3	2505-339	½-13 X 1-1/2 CARRIAGE BOLT GRADE 5	4
4	2520-352	½-13 HEX NUT GRADE 2	4
5	2520-357	½-13 HEX LOCK NUT GRADE 2	3
6	2520-459	5/8-11 HEX LOCK NUT GRADE 5	2
7	2520-469	5/8-18 SLOTTED HEX NUT	1
8	2525-352	½ LOCK WASHER	4
9	2526-449	5/8 FLAT WASHER ¼" THICK	1
10	2526-453	5/8 SAE FLAT WASHER	1
11	2531-102	1/8 X 1-1/4 COTTER PIN	1
12	2533-110	¼-28 STRAIGHT LUBE FITTING	1
13	2550-027	CONE LM67048	2
14	2550-029	CUP LM67010	2
15	2550-066	SEAL	1
16	2570-375	HUB CAP	1
17	2900-102	HUB ASSEMBLY	1
18	2900-105	HUB WITH CUPS	1
19	2960-230	COULTER ARM	1
20	2960-133	COULTER ARM ASSEMBLY	1
21	2987-301	HUB CAP RETAINER	1
22	2571-206	.197 X 16 SMOOTH COULTER (SHOWN)	1
	2571-172	.157 X 15.9 25 WAVE COULTER	1
	2571-162	.157 X 15.9 13 WAVE COULTER	1
	2571-161	.157 X 15.9 RIPPLE COULTER	1
	2571-156	.157 X 15.8 8 WAVE COULTER	1
	2571-153	.157 X 16 BUBBLE COULTER	1
23	2960-231	COULTER/RESIDUE MANAGER MOUNT (KINZE)	1
	2960-228	COULTER MOUNT (KINZE)	1
	2960-229	COULTER MOUNT (JD MEII/1700)	1
	2960-232	COULTER/RESIDUE MANAGER MOUNT (JD MEII/1700)	1

PART IDENTIFICATION

2960-039

UNIT MOUNTED MONOSEM COULTER

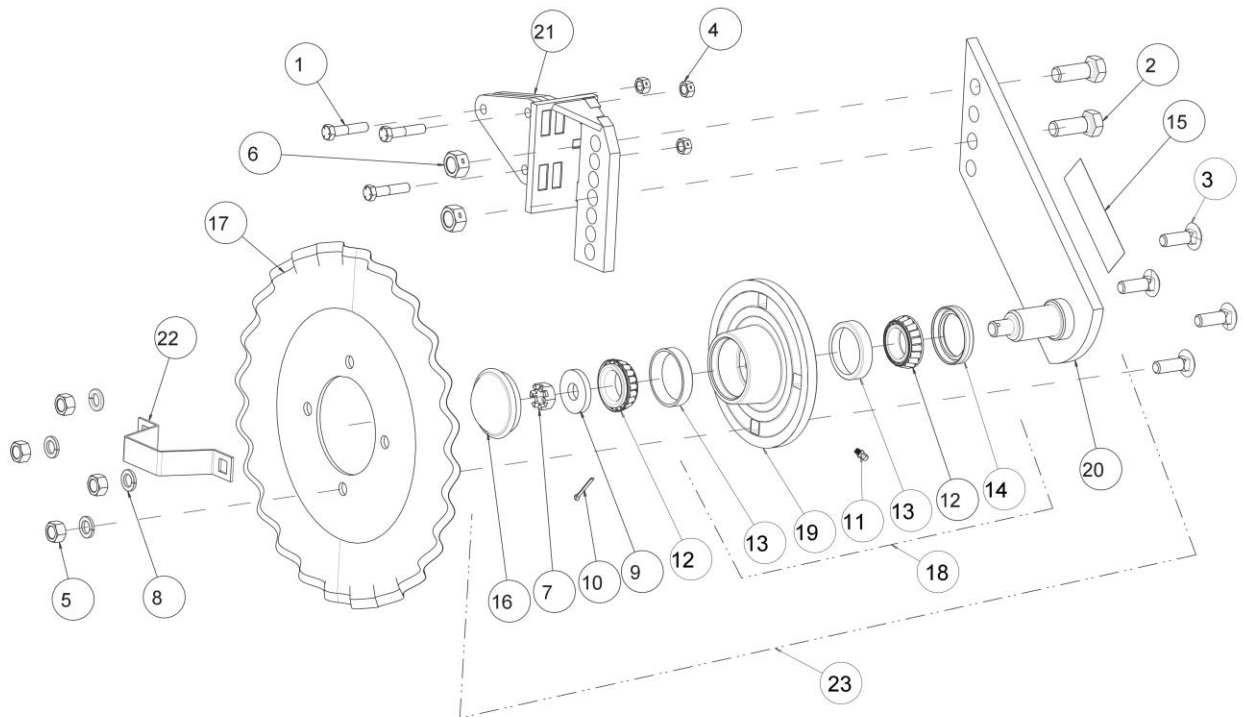

ITEM	PART #	DESCRIPTION	QTY
1	2502-245	3/8-16 X 1-3/4 HHCS GR 5 ZP	3
2	2502-331	5/8-11 X 1-3/4 HHCS GR5 ZP	2
3	2505-339	1/2-13 X 1-1/2 CARBLT G5ZP	4
4	2520-255	3/8-16 LOCK HEX NUT, GR A, ZP	3
5	2520-352	1/2-13 HEX NUT ZP	4
6	2520-459	5/8-11 LOCK HEX NUT, GR B, ZP	2
7	2520-469	5/8-18 SLOTTED HEX NUT,PLAIN, GR2	1
8	2525-352	1/2 MED LOCKWASHER ZP.	4
9	2526-449	5/8 FLATWASHER 1/4 +/--.010 THK, ZP	1
10	2531-102	1/8 X 1-1/4 COTTER PIN, PLAIN	1
11	2533-110	1/4-28 ZERK STRAIGHT SELF-TAP	1
12	2550-027	CONE, LM67048, KOYO	2
13	2550-029	CUP, LM67010	2
14	2550-066	SEAL	1
15	2565-162	YETTER DECAL	1
16	2570-375	HUB CAP, WILTON #909902	1
17	2571-166	.157 X 14.56, 25 FLUTE PLATE	1
18	2900-102	HUB SUB-ASSEMBLY	1
19	2900-105	HUB PRESSED ASSEMBLY	1
20	2960-235	COULTER ARM W.A.	1
21	2960-236	MOUNT BRACKET W.A.	1
22	2987-301	HUB CAP RETAINER	1
23	2960-162	ARM ASSEMBLY	1

PART IDENTIFICATION

2967-007

U.N.T. RESIDUE MANAGER

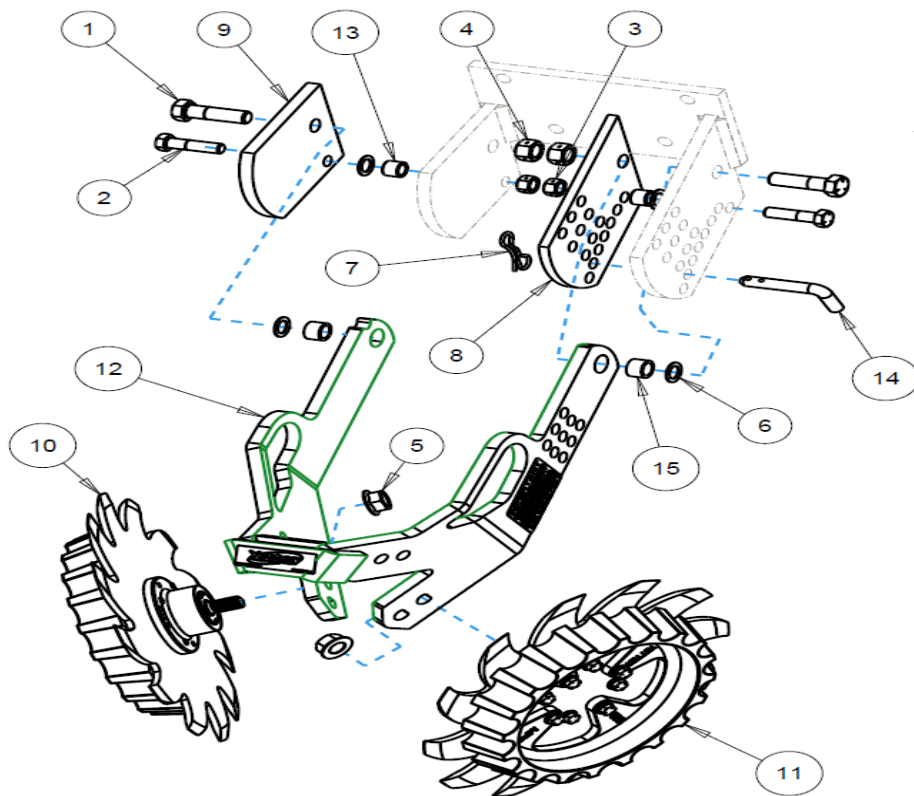

ITEM	PART NO.	DESCRIPTION	QTY
1	2502-332	5/8-11 X 2-1/4 HHCS GR5 ZP	2
2	2502-351	1/2-13 X 2 HHCS GR.5 ZP	2
3	2520-357	1/2-13 LOCK HEX NUT, GR A, ZP	2
4	2520-459	5/8-11 LOCK HEX NUT, GR B, ZP	2
5	2520-465	5/8-11 SER. FLANGE NUT, GR 8, ZP	2
6	2527-562	5/8IDXIODX.049+- .002M BU ZP	4
7	2570-448	.120 BOWTIE LOCKING COTTER ZP	1
8	2960-401	ADJ SUPPORT PLATE	1
9	2960-402	PIVOT PLATE	1
10	2966-116-ST-FW	SHRKTH FLOATER WL ASSY, RH	1
11	2966-117-ST-FW	SHRKTH FLOATER WL ASSY, LH	1
12	2967-068	U.N.T. COMBO ARM ASSEMBLY	1
13	2967-622	9/16" SPACER ZP	2
14	2984-326	R.M. UPSTOP PIN ZP	1
15	6000-335	9/16" BUSHING	2

PARTS IDENTIFICATION

SCRAPERS (OPTIONAL)

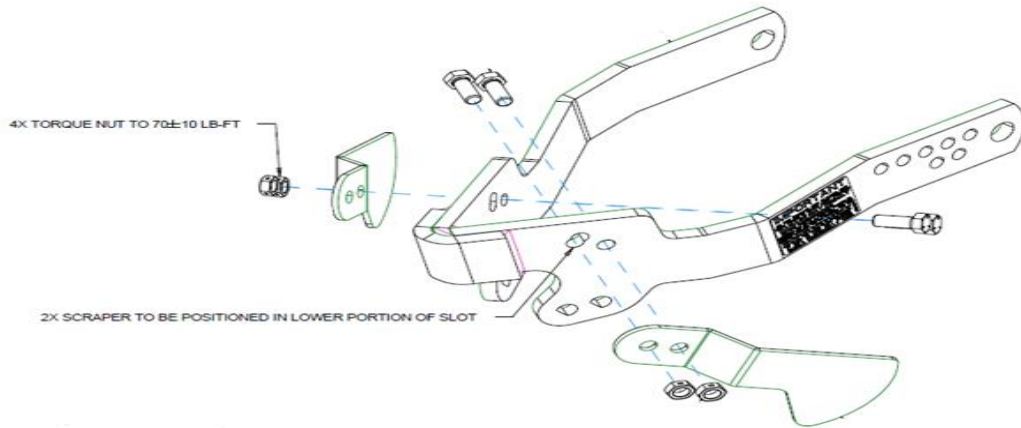

PART NO.	DESCRIPTION	QTY
2502-293	1/2-13 X 1-1/4 CAP SCREW GRADE 5	4
2520-364	1/2-13 JAM LOCK NUT	4
2967-630	SCRAPER RIGHT HAND	1
2967-631	SCRAPER LEFT HAND	1

OPTIONAL

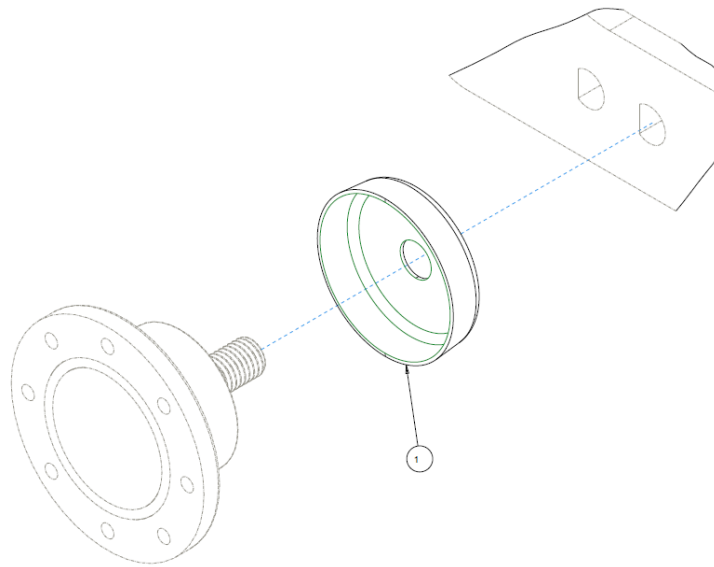

ITEM	PART NO.	DESCRIPTION	QTY
1	2965-550	BEARING SHIELD	1

PARTS IDENTIFICATION

13" TAPER TOOTH SPOKE WHEEL

2966-117 (SHOWN)

2966-116--FW

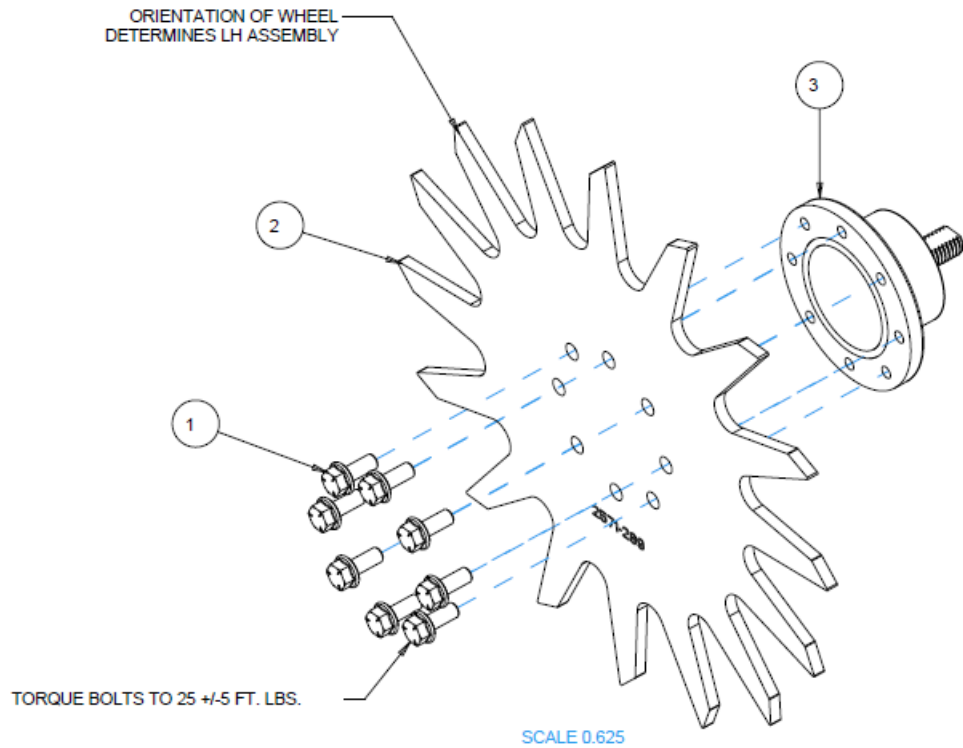

ITEM	PART NO.	DESCRIPTION	QTY
1	2502-220	5/16-18 X 3/4 HHFS GR5 ZP	8
2	2571-289	13" TAPER TOOTH SPOKE WHEEL, 8 BOLT	1
3	2965-502	HUB ASSEMBLY, 1.157 SPINDLE	1

PARTS IDENTIFICATION

13" BEVEL WHEEL

2966-117-BW (SHOWN)

2966-116-BW

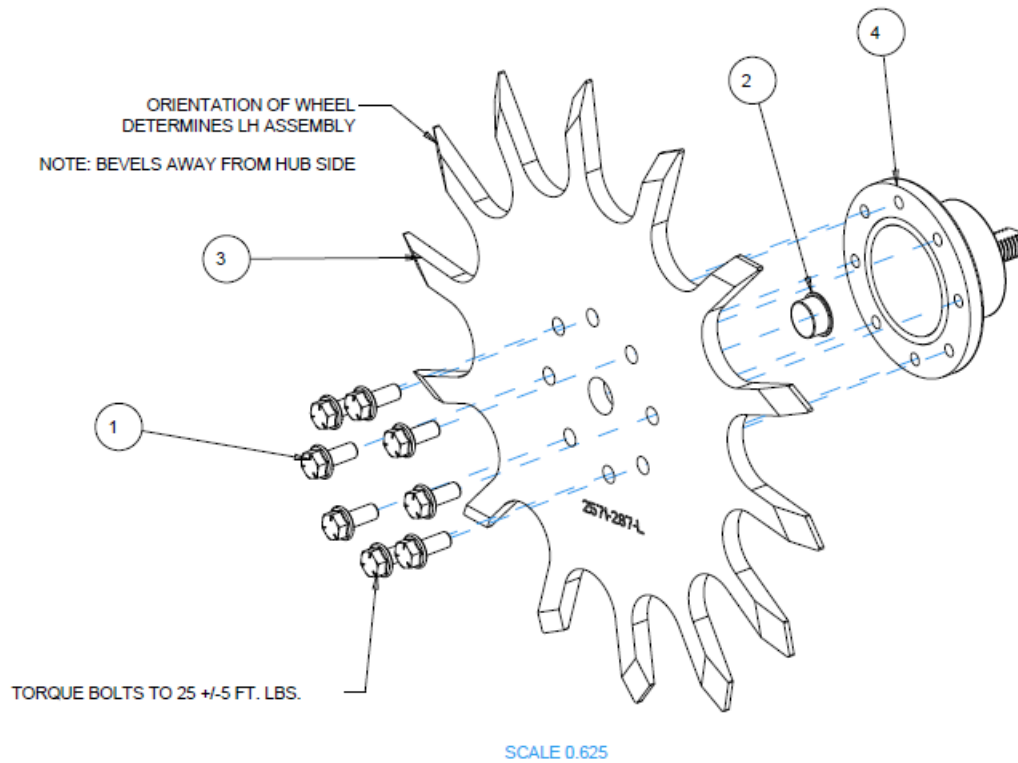

ITEM	PART NO.	DESCRIPTION	QTY
1	2502-220	5/16-18 X 3/4 HHFS GR5 ZP	8
2	2570-994	BEVEL WHEEL CENTER HOLE PLUG	1
3	2571-287-L	13" BEVEL WHEEL, 8 BOLT, LH	1
4	2965-502	HUB ASSEMBLY, 1.157 SPINDLE	1

PARTS IDENTIFICATION

13" SHARK WHEEL

2966-117-ST-FW (SHOWN)

2966-116-ST-FW

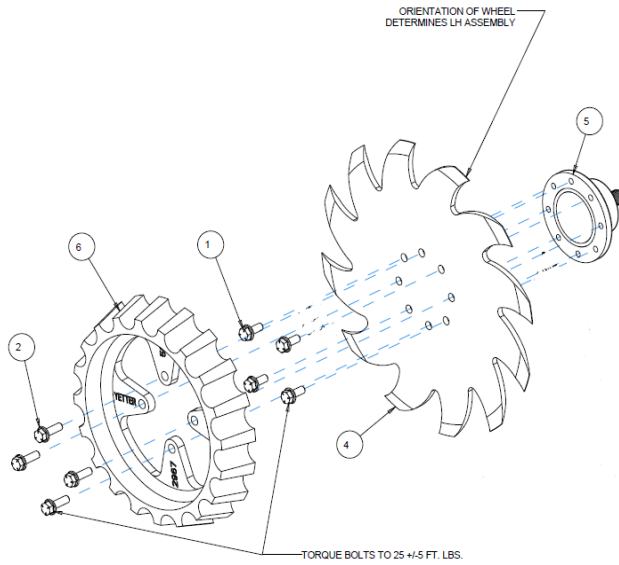

2966-117-ST-PFW

ITEM	PART NO	DESCRIPTION	QTY
1	2502-220	5/16-18 X 3/4 HHFS GRADE 5	4
2	2502-221	5/16-18 X 1 HHFS GRADE 5	4
3	2571-286	SHARKTOOTH WHEEL 8 BOLT	1
4	2965-502	HUB ASSEMBLY 1.157 SPINDLE	1
5	2967-957	SHARKTOOTH TIMED FLOATER WHEEL	1

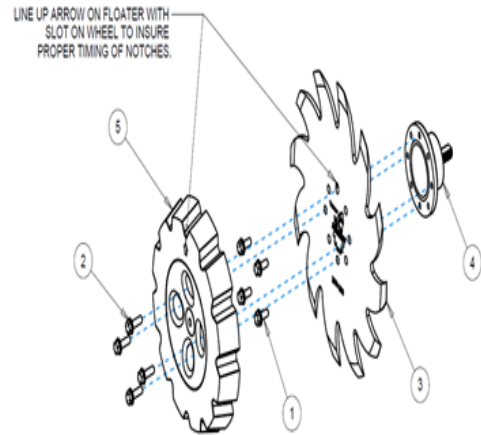

ITEM	PART NO.	DESCRIPTION	QTY
1	2502-220	5/16-18 X 3/4 HHFS GR5 ZP	4
2	2502-221	5/16-18 X 1 HHFS GR5 ZP	4
3	2515-562	13" WHEEL COVER, BLACK	2
4	2571-286	SHARKTOOTH WHEEL, 8 BOLT	1
5	2965-502	HUB ASSEMBLY, 1.157 SPINDLE	1
6	2967-560	FLOATER WHEEL	1

PARTS IDENTIFICATION

2966-116-STF-PFW (SHOWN) RIGHT HAND 2966-117-STF-FW LEFT HAND

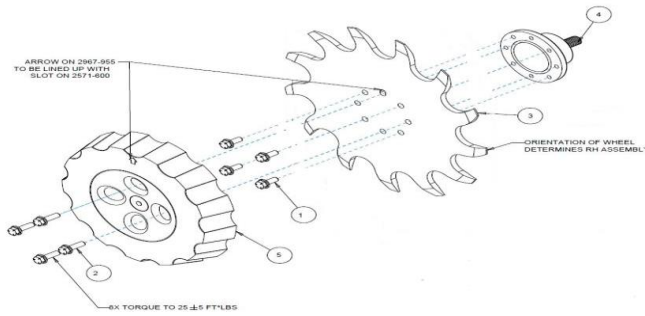

ITEM	QTY	PART NO.	DESCRIPTION
1	4	2502-220	5/16-18 X 3/4 HHFS BOLT GR5
2	4	2502-221	5/16-18 X 1 HHFS BOLT GR5
3	1	2571-600	SHARKTOOTH FINGER WHEEL
4	1	2965-502	HUB ASSEMBLY 1.157" SPINDLE
5	1	2967-955	STF TIMED FLOATER WHEEL

8 BOLT HUB ASSEMBLY

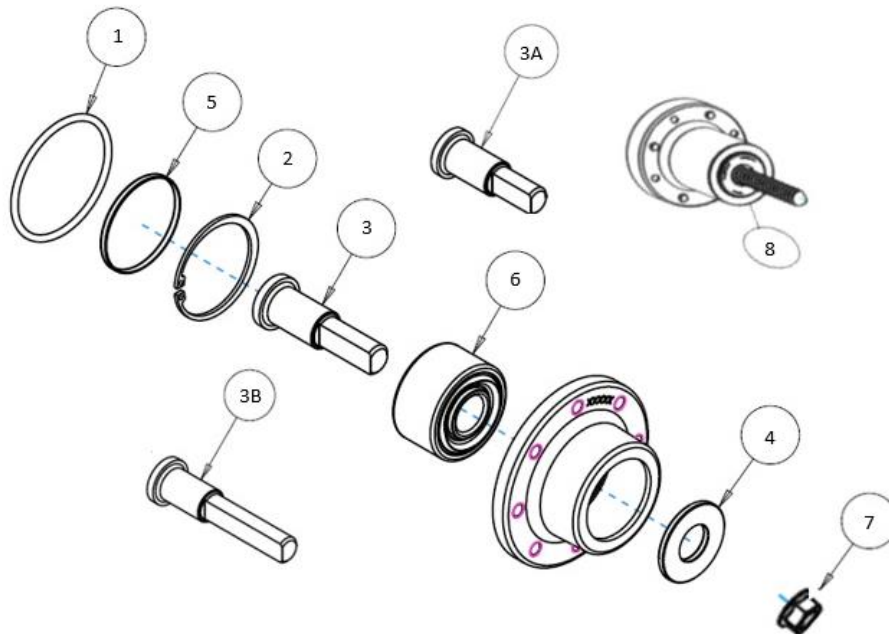

ITEM	PART #	DESCRIPTION	QTY
1	2550-074	O-RING 3.55MM X 56MM ID	1
2	2550-529	SNAP RING	1
3	2965-600A	SHAFT 73 MM (2965-500A HUB ASSEMBLY)	1
3A	2965-602A	SHAFT 66.7 MM (2965-502A HUB ASSEMBLY)	1
3B	2965-601A	SHAFT 98.4 MM (2965-501A HUB ASSEMBLY)	1
4	2965-604A	SPACER	1
5	2965-605A	CAP	1
6	2965-606	BEARING	1
7	2520-465	5/8-11 FLANGE HEX NUT GRADE 8	1
8	2965-500A	HUB ASSEMBLY 1.406" SPINDLE	1
	2965-501A	HUB ASSEMBLY 2.406" SPINDLE	1
	2965-502A	HUB ASSEMBLY 1.157" SPINDLE	1

FIELD SERVICE KITS

- 2965-119 - SERVICE KIT FOR 2570-740-2.812 D-BOLT
- 2965-120 - SERVICE KIT FOR 2570-742-3.812 D-BOLT
- 2965-121 - SERVICE KIT FOR 2570-766-2.562 D-BOLT

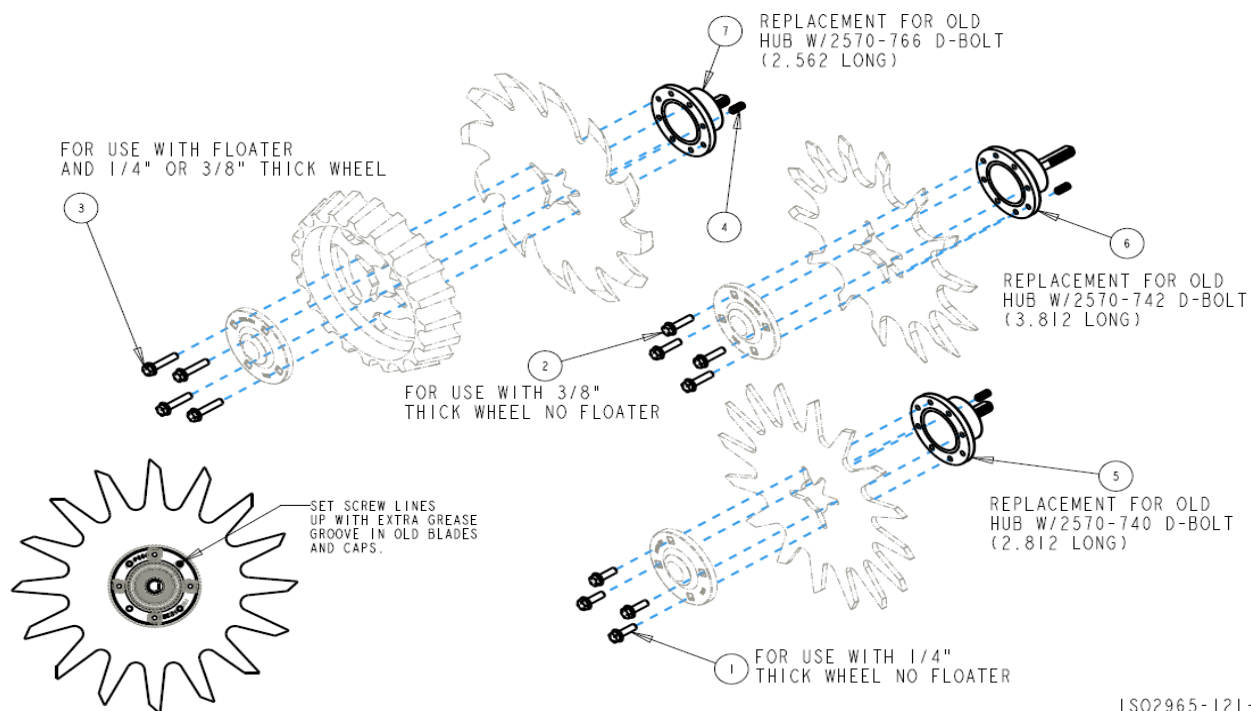

ISO2965-121-2

ITEM	PART NO	DESCRIPTION	QTY
1	2502-221	5/16-18 X 1 HHFS GRADE 5	4
2	2502-222	5/16-18 X 1-1/4 HHFS GRADE 5	4
3	2502-225	5/16-18 X 1-1/2 HHFS GRADE 5	4
4	2940-560	SET SCREW	1
5	2965-500	HUB ASSEMBLY 1.406 SPINDLE	1
6	2965-501	HUB ASSEMBLY 2.406 SPINDLE	1
7	2965-502	HUB ASSEMBLY 1.157 SPINDLE	1

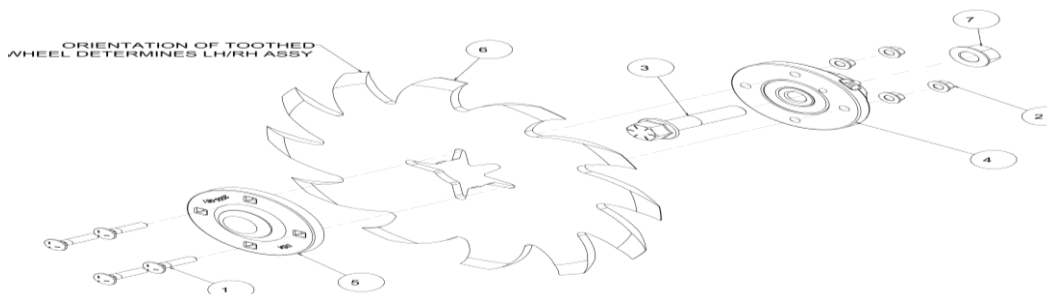

ITEM	PART NO	DESCRIPTION	QTY
1	2505-207	5/16-18 X 1-1/4 CARRIAGE HEAD BOLT GRADE 5	4
2	2520-206	5/16-18 FLANGE LOCK NUT	4
3	2570-766	D-BOLT FLANGE HEAD 5/8-11 X 2.562 GRADE 8	1
4	2965-128	HUB/BEARING ASSEMBLY	1
	2550-069	SEAL	1
	2570-594	BEARING	1
	2570-715	INSERT	1
	2965-351	HUB	1
	2533-110	GREASE FITTING	1
5	2965-352	HUB CAP	1
6	2967-602	SHARK TOOTH WHEEL	1
7	2520-465	5/8-11 FLANGE LOCK NUT GRADE 8	1

PART IDENTIFICATION

2967-901

CLEANSWEEP® CYLINDER MOUNT

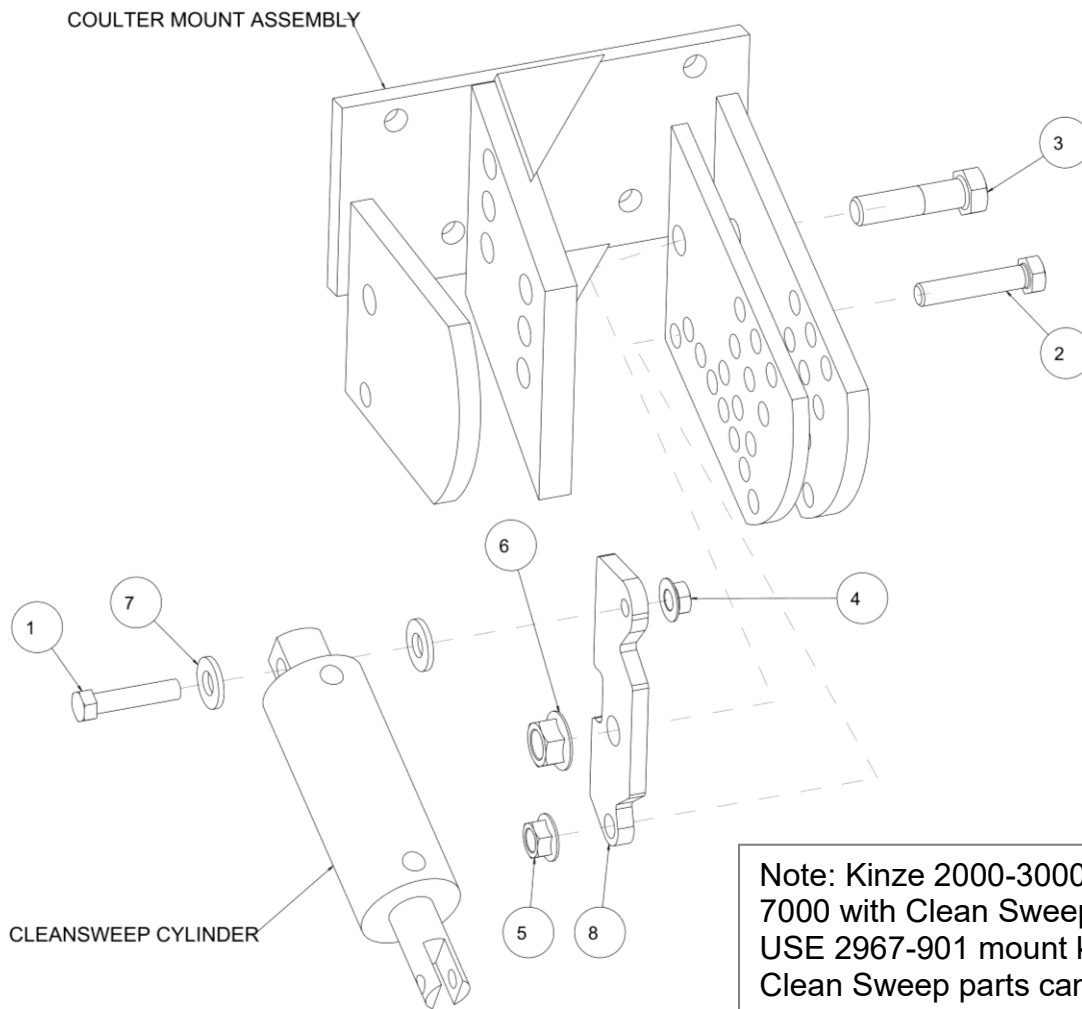

Note: Kinze 2000-3000, White 6000, JD 7000 with Clean Sweep™ Kit 755185 MUST USE 2967-901 mount kit.
 Clean Sweep parts can be ordered separately per row from Precision Planting:
 2) 95207 Bolt
 1) 755019 Pin
 2) 755028 Cotter Pin
 1) 755148 Bracket
 1) 755023 Air Cylinder

ITEM	PART #	DESCRIPTION	QTY
1	2502-267	7/16-14 X 2 HHCS GR 5 ZYD	1
2	2502-353	1/2-13 X 2 1/2HHCS GR8 ZYD	1
3	2502-393	5/8-11 X 2 1/2HHCS GR 5 ZP	1
4	2520-307	7/16-14 FLANGE LOCK NUT	1
5	2520-361	1/2-13FLANGE WHZLCK HXNT, GR 5, ZP	1
6	2520-464	5/8-11 WHIZLOCK HEX NUT, GR 2, ZP	1
7	2526-355	1/2 FLAT WASHER HARD'ND ZP	2
8	2967-838	MOUNT, CYLINDER	1

TROUBLESHOOTING

Problem	Cause	Solution
Cannot adjust coulter depth shallow enough.	Planter frame not set correctly.	Ensure that in operation the planter frame is at correct height (20"-22") and level the toolbar, refer to opposite page.
	Coulter blade is too big.	Blade must be 16" diameter or smaller.
	Planter opener blades worn.	Replace planter opener blades if worn smaller than 14 1/4" diameter.
Cannot adjust coulter deep enough.	Coulter blade worn too small.	Replace coulter blade.
Coulter will not penetrate.	Lack of spring tension.	Increase spring tension.
Coulter penetrates too much.	Excessive spring down pressure.	Reduce spring tension.
Seed placement is too deep.	Coulter blade set too deep relative to openers.	Shallow up coulter depth.
Optional wavy blade disturbs too much soil.	Soil too damp or loose.	Reduce ground speed.
		Install a less aggressive blade. Example: smooth or ripple.
Drive chain rubs on springs.	Close fitting parts.	Not detrimental to operation of planter.
No spring tension.	Planter frame not set correctly.	Check planter frame settings, see above.
	Spring adjustment pin not installed properly.	Check installation of pin.
	Broken springs.	Replace broken or damaged parts.

OPERATION PRECAUTIONS

STOP

Read this before using the Yetter product.

- MACHINE OPERATION

 **NOTICE:** failure to properly set the planter frame height and levelness can result in less than successful operation of the planter and the Yetter product and may result in damaged equipment. All operators should read and thoroughly understand the instructions given prior to using the Yetter product.

NOTICE: **DO NOT** use this product if the planter is not adjusted properly!



Leveling the planter:

With the planter lowered to proper operating height (**Usually 20"-22"**). **Read the planter operator's manual for recommended setting**. Check to be sure the toolbar and row unit parallel arms are level fore and aft. **Re-check** when the planter is in the **field** and has been **fully loaded** with seed, fertilizer, granular chemicals, etc. Also, a field check with a bubble level on the frame should be made of the hitch height to ensure level operation front to back.

It is important for the planter to operate level laterally. Tire pressure must be maintained at pressures specified by the manufacturer.

Field and actual planting conditions change and will dictate planter frame heights. You must ensure that the row unit parallel arms are approximately parallel with the ground.

 **NOTICE:** For proper operation of the planter attachments and row units, it is imperative that the planter toolbars and row unit parallel arms be level side-to-side and front-to-rear. The toolbar frame should operate at a 20"-22" height from the **planting surface**. Check the manufacturer's operator's manual for instructions on how to adjust the frame height and levelness.

PLANTER HEIGHT ADJUSTMENT

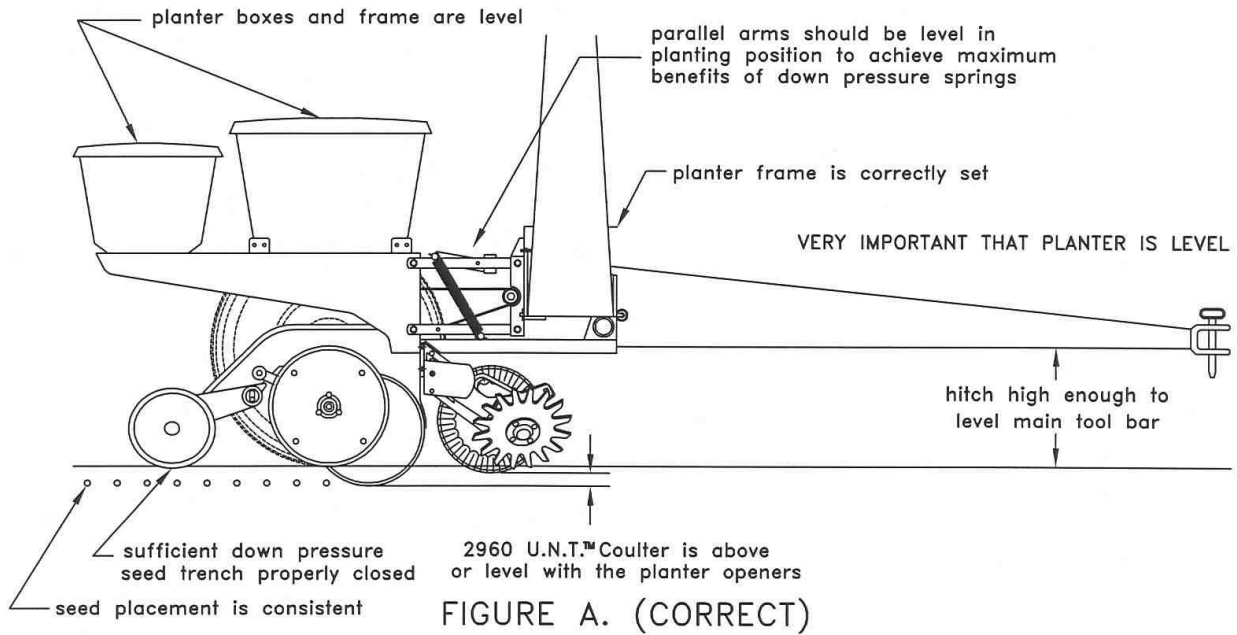

1720-19

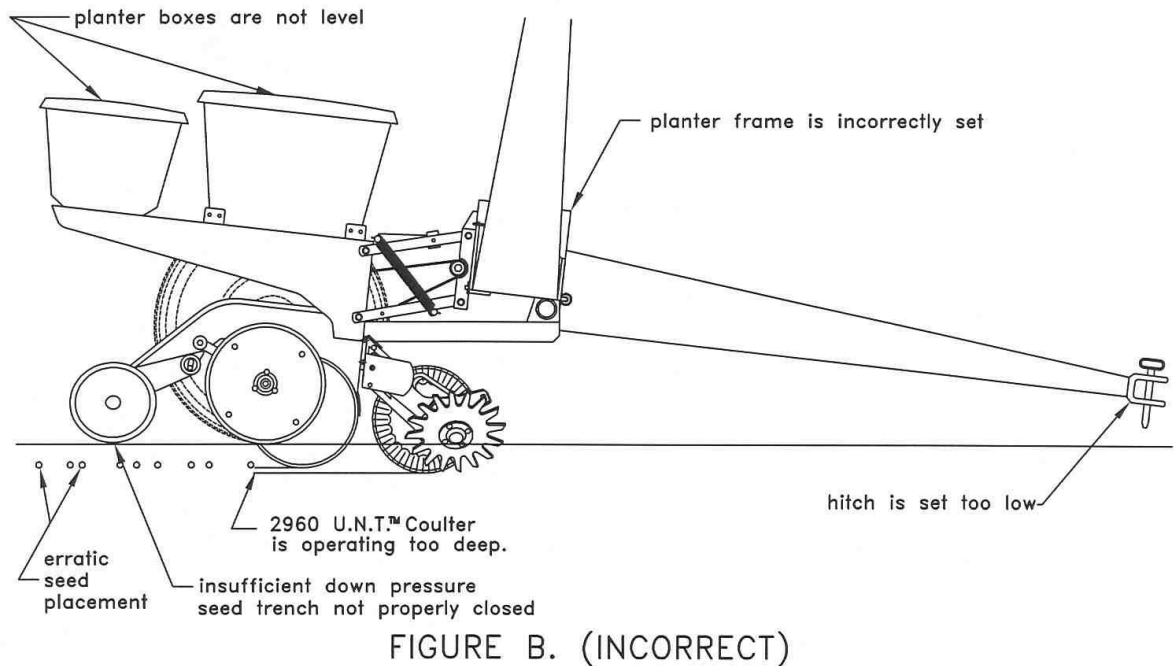

Figure A. – The planter hitch and frame are both 20” off the ground. To ensure this, visually check to see that the planter boxes are level and that the planter unit parallel arms are also parallel with the ground. **When using planter attachments located in front of the planter unit, this setting is very important.**

Figure B. – The planter hitch is set too low while the planter frame remains at 20” off the ground! Notice from the illustration that the unit mounted coulters is running deeper in the ground than the planter unit. This condition can result in the formation of an air pocket below the seedbed, which will in turn dramatically decrease seed growth.

NOTE: Both illustrations are strictly for reference only. They are intended to show that proper adjustment of the hitch height is critical. Consult your planter operator’s manual for the proper height adjustment of the hitch.



A Tradition of Solutions since 1930

Yetter Farm Equipment Co

PO BOX 358 109 S. McDonough

Colchester, IL 62326-0358

Phone: 309-776-4111

Toll Free: 800-447-5777

Email: info@yetterco.com

For updated models and manuals visit the Yetter website:

www.yetterco.com

© Yetter Farm Equipment Co. All Rights Reserved

2565-692_REV_V • 06/2026