



**2940 AIR ADJUST RESIDUE MANAGER**

OPERATOR'S MANUAL  
PART IDENTIFICATION  
2565-773\_REV\_D1 • 09/2024



\*Patented

**YETTER MANUFACTURING CO.**  
FOUNDED 1930

Colchester, IL 62326-0358  
Toll free: 800/447-5777  
309/776-3222 (Fax)  
Website: [www.yetterco.com](http://www.yetterco.com)  
E-mail: [info@yetterco.com](mailto:info@yetterco.com)



**YETTER**

# FOREWORD

You've just joined an exclusive but rapidly growing club.

For our part, we want to welcome you to the group and thank you for buying a Yetter product.

We hope your new Yetter products will help you achieve both goals-increase your productivity and increase your efficiency so that you may generate more profit.

This operator's manual has been designed into four major sections: Foreword, Safety Precautions, Installation Instructions and Parts Breakdown.

This **SAFETY ALERT SYMBOL** indicates important safety messages in the manual. When you see this symbol, be alert to the possibility of **PERSONAL INJURY** and carefully read the message that follows.

 **DANGER:** Indicates an imminently hazardous situation which, if not avoided "will" result in death or serious injury. This signal word is to be limited to the most extreme situations

 **WARNING:** Indicates a potentially hazardous situation which, if not avoided, "could" result in death or serious injury.

 **CAUTION:** Indicates a potentially hazardous situation, which if not avoided, "may" result in minor or moderate injury. It may also be used to alert against unsafe practices.

 **NOTICE:** Indicates information considered important, but not hazard related (e.g., messages relating to property damage).

It is the responsibility of the user to read the operator's manual and comply with the safe and correct operating procedure and to lubricate and maintain the product according to the maintenance schedule in the operator's manual.

The user is responsible for inspecting his machine and for having parts repaired or replaced when continued use of the product would cause damage or excessive wear to the other parts.

It is the user's responsibility to deliver his machine to the Yetter dealer who sold him the product for service or replacement of defective parts, which are covered by the warranty policy.

If you are unable to understand or follow the instructions provided in this publication, consult your local Yetter dealer or contact:

## YETTER MANUFACTURING CO.

309/776-4111

800/447-5777

309/776-3222 (FAX)

Website: [www.yetterco.com](http://www.yetterco.com)

E-mail: [info@yetterco.com](mailto:info@yetterco.com)

## WARRANTY POLICY

Yetter Manufacturing warrants all products manufactured and sold by it against defects in material. This warranty being expressly limited to replacement at the factory of such parts or products as will appear to be defective after inspection. This warranty does not obligate the Company to bear cost of labor in replacement of parts. It is the policy of the company to make improvements without incurring obligations to add them to any unit already sold. No warranty is made or authorized to be made, other than herein set forth. This warranty is in effect for one year after purchase.

Dealer : \_\_\_\_\_

**Yetter Manufacturing warrants its own products only and cannot be responsible for damage to equipment on which mounted.**



## SAFETY PRECAUTIONS



**A brief description of signal words that may be used in this manual:**

**DANGER:** Indicates an imminently hazardous situation which, if not avoided “will” result in death or serious injury. This signal word is to be limited to the most extreme situations.

**WARNING:** Indicates a potentially hazardous situation which, if not avoided, “could” result in death or serious injury.

**CAUTION:** Indicates a potentially hazardous situation, which if not avoided, “may” result in minor or moderate injury. It may also be used to alert against unsafe practices.

**NOTICE:** Indicates information considered important, but not hazard related (e.g., messages relating to property damage).

**Consult your implement and tractor operator’s manual for correct and safe operating practices. Be aware of towed implement width and allow safe clearance.**

Safety decals are placed on the implement to alert the operator and others to the risk of personal injury or unsafe operation during normal operations and servicing.

1. The safety decals must be kept clean and in good condition to ensure that they are legible.
2. Safety decals must be replaced if they are missing or illegible.
3. When components are replaced during repair or servicing, check that the new components include the necessary safety signs.
4. Replacement safety decals may be obtained from your local dealer.



### WARNING

Read these instructions carefully to acquaint yourself with the Equipment. Working with unfamiliar equipment can lead to accidents.

Never park the equipment on a steep incline or leave the equipment running unattended.

Never clean, lubricate or adjust a machine that is in motion.

Always check that straps are secure.

Make sure latches are in pinned position when moving equipment.

Do not allow children to operate this equipment.

Do not allow riders on the equipment, trailer and/or pick-up.

Use speed and caution dictated by the terrain being traversed. Do not operate on any slope steep enough to cause tipping or loss of control.

Read and understand the operator’s manual and require all other persons who will operate the equipment to do the same.

If operating on public roadways, where legal, be certain all lighting is operating properly and observe all traffic laws.

Beware of increased stopping distances and control effort when operating with implements attached.

Be familiar with all controls and be prepared to stop equipment quickly in an emergency.

**FAILURE TO HEED MAY RESULT IN PERSONAL INJURY OR DEATH.**

# BOLT TORQUE

## Mounting bolts and hardware



All hardware used on the 2940 Air Adjust is Grade 5 unless otherwise noted. Grade 5 cap screws are marked with three radial lines on the head. If hardware must be replaced, be sure to replace it with hardware of equal size, strength and thread type. Refer to the torque values chart when tightening hardware.



**NOTICE:** Over tightening hardware can cause as much damage as when under tightening. Tightening hardware beyond the recommended range can reduce its shock load capacity.

The chart below is a guide for proper torque. Use it unless a specified torque is called out elsewhere in the manual. Torque is the force you apply to the wrench handle or the cheater bar, times the length of the handle or bar. Use a torque wrench whenever possible.

The following table shows torque in ft. lbs. for coarse thread hardware.

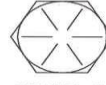
BOLT DIA. AND THREADS PER INCH	 GRADE 2	 OR  GRADE 5 A-325	 GRADE 8
3/8-16	25	35	50
7/16-14	35	55	80
1/2-13	55	85	125
9/16-12	75	125	175
5/8-11	105	170	235
3/4-10	185	305	425
7/8-9	170	445	690
1-8	260	670	1030
1 1/8-7	365	900	1460
1 1/4-7	515	1275	2060
1 3/8-6	675	1675	2700
1 1/2-6	900	2150	3500
1 3/4-5	1410	3500	5600

## TABLE OF CONTENTS

Safety.....	2-3
Bolt Torque.....	4
2940 Components, Kits, Accessories, and Ordering Part Numbers.....	5-8
Introduction & System Requirements.....	9
System Information.....	10-15
Installation Instructions.....	16-59
<b>Installation Guide.....</b>	<b>16</b>
<b>Residue Manager/RM Coulter Combo.....</b>	<b>17-20</b>
<b>Cab Controller.....</b>	<b>21</b>
<b>Compressor .....</b>	<b>22-23</b>
<b>Compressor Power Cable &amp; Harnesses.....</b>	<b>24</b>
<b>Dump Valve Assembly.....</b>	<b>25</b>
<b>Airline &amp; Dump Valve.....</b>	<b>26-59</b>
Operation.....	60-67
Maintenance.....	68-72
Parts Identification.....	72-87
Troubleshooting.....	88

# Components, Kits, Accessories, & Ordering Numbers

## Residue Manager Kits

2940-001	Pneumatic Assembly with choice of wheel kit
2940-002	Pneumatic Narrow Assembly with choice of wheel kit
2940-003	Pneumatic CNH Assembly with choice of wheel kit
2940-004	Pneumatic CNH Narrow Assembly with choice of wheel kit
2940-010	Pneumatic RM/Coulter Combo with choice of wheel kit

## Control Kits

2940-050	Electric Pneumatic Compressor Kit
----------	-----------------------------------









## Air Lines and Wiring Kits

2940-065	20' planter wiring and tubing kit
2940-066	30' planter wiring and tubing kit
2940-067	40' planter wiring and tubing kit
2940-068	48' planter wiring and tubing kit
2940-069	60'-66' planter wiring and tubing kit
2940-070	80'-90' planter wiring and tubing kit
2940-071	120' planter wiring and tubing kit
2940-072	Split Row/Interplant Kit
2940-073	Center Tube Extension Kit

## Mounting Kits

2940-085	Compressor Mount Bracket Two Point Hitch Kit for 2940-101
2940-086	Compressor Mount Bracket Draft Tube Kit or Universal Kit for 2940-101

## Part Numbers and Descriptions

2940-049	Air Adjust Mount Ext. Kit (For JD HD scrapers)→	
2940-079	Switch Panel Resisted Adapter-----→	
2940-087	Rear Isobus Kit (John Deere Only)	
2940-100	Data Panel/Cab Controller-----→	
2940-101	Electric Compressor with Single 3 Port PQE---→	
2940-112	VDM 12 Volt Controller-----→	
2940-113	RAM Cab Controller Mount Kit-----→	
2940-136	Dump Valve Kit-----→	
2940-139	Pressure On Valve-----→	
2940-142	Mounting Bolt Bag-2940-001 & 2940-002	

2940-144  
2940-145

Mounting Bolt Bag-2940-100 Cab Controller  
Mounting Bolt Bag-2940-003 & 2940-004

## Components, Kits, Accessories, & Ordering Numbers

2940-147

Package of 10 Tees----->



2940-148

Package of Zip Ties (100) ----->



2940-150

Main Power Cable with 80A Breaker----->



2940-151

10 ft. Main Power Cable Extension ----->



2940-152

Hitch to Cab Controller CAN Cable----->



2940-153

Cab Controller IGN/GRD Supply Harness->



2940-154

30 ft. Dump Valve Cable Black ----->



2940-155

30 ft. Dump Valve Cable White----->



2940-156

15 ft. Dump Valve Cable Black

2940-157

15 ft. Dump Valve Cable White

2940-158

3 in. Y Harness Black----->



2940-159

3 in. Y Harness White----->



2940-160

5 ft Dump Valve Cable White

2940-161

5 ft Dump Valve Cable Black

2940-162

Dump Valve Harness at Compressor----->



2940-163

20 ft Main Power Extension----->



# Components, Kits, Accessories, & Ordering Numbers

2940-164	5 ft CAN Aux To Air Harness----->	
2940-165	10 ft CAN Aux to Air Harness	
2940-166	VDM Power Cable with 40 Amp Breaker--->	
2940-167	10 ft VDM Power Cable Extension----->	
2940-168	20 ft VDM Power Cable Extension	
2940-169	10 ft Cab to Hitch Extension----->	
2940-170	10 ft CAN Aux to Air Harness Extension --->	
2940-171	30 ft CAN Aux to Air Harness Extension	
2940-172	5 ft Hitch to Air System Isobus	
2940-173	10 ft Hitch to Air System Isobus----->	
2940-174	Spare Fitting Bag	
2940-180	ISOBUS 10 ft to Air Assembly Harness---->	
2940-185	Bolt bag for 2940-085 mounting kit	
2940-186	Bolt bag for 2940-086 mounting kit	
2940-187	2940-010 Assembly/Mounting Bot Bag	
2940-190	Pneumatic RM Mount Assembly	
2940-190-CIH	Pneumatic RM Mount Assembly for CASE	
2940-191	Pneumatic RM/Coulter Combo Assembly	
2940-200	Air Adjust Wheel Mount W.A. (2940-140)	
2940-201	Air Adjust Wheel Mount W.A. Narrow (2940-140)	
2940-209	Mount Adaptor, CASE----->	
2940-215	Air Adjust Wheel Mount W.A. (2940-190)	
2940-216	Air Adjust Narrow Wheel Mount W.A. (2940-190)	
2940-306	6" Smaller Air Bag/Up Pressure Air Bag----->	
2940-308	8" Larger Air Bag/Down Pressure Air Bag--->	
2940-336	MAC Dump Valve----->	

2940-337

3/8 Push to Connect(PTC) elbow 1/8 NPT-->



## Components, Kits, Accessories, & Ordering Numbers

2940-338

3/8 PTC Tee----->



2940-339

3/8 PTC Straight 1/8 NPT(pipe thread)----->



2940-341

Air Tubing Cutter----->



2940-342

Ball Valve----->



2940-345

Black 3/8 Air Tubing 100ft roll----->



2940-346

Blue 3/8 Air Tubing 100ft roll----->



2940-352

3/8 PTC Plug(package of 5)----->



2940-358

3/8 PTC Union, Straight----->



2940-390

Extreme Air Magnum Compressor & Filter->



2940-395

Replacement Filter Element----->



2940-396

Filter Pre-Cleaner-Compressor----->



2940-430

20 ft Can Aux to Air Harness Extension----->





# INTRODUCTION

The Yetter Electric Air Compressor assembly builds 95psi of air pressure and dispenses that air to the row cleaners' air bags as the operator commands it from the tractor cab. Yetter electric compressors are durably constructed and designed for easy integration to operate the Yetter 2940 Air Adjust System. The ability of the air adjustment allows the operator to adjust the row cleaner precisely on the move without leaving the tractor cab resulting in more acres planted. The precise adjustments give the row units and planter a more even, smoother ride leading to more accurate seed placement and seed depth resulting in even emergence.

## SYSTEM REQUIREMENTS

### POWER SUPPLY

The compressor and the VDM (Valve Drive Module) each use 12V from the battery.

The 2940-100 Cab Controller uses a switched power source. The 2940-153 will need connected to a switched power source. (Connector to the tractor not included)

**A CIGARETTE LIGHTER OUTLET IS NOT A SWITCHED POWER SOURCE AND THEREFORE SHOULD NOT BE USED.**

### SWITCHED POWER SOURCE CONNECTOR PART #'S:

**JOHN DEERE P/N:** RE67013

**CNH P/N:** 187103A1

### FUSE PROTECTION

To protect the compressor Assembly from damage always ensure the integrity of the integrated 40 amp and 80 amp circuit breaker at the tractor battery where cable connects to the battery in case of short or over-circuit. When connected correctly, the tractor has a fuse to protect the cab controller located in the tractor's fuse panel. **NEVER MOUNT THE COMPRESSOR ASSEMBLY MORE THAN 50 FEET FROM THE BATTERY USING THE PROVIDED MAIN POWER CABLES. THIS WILL WEAKEN THE 80AMP BREAKER TO THE POINT OF FAILURE. IF MORE THAN 50 FEET, BUILD POWER CABLE(S) TO LENGTH USING 0-2 GAUGE CABLE!**

### AIR COMPRESSOR MAINTENANCE

To prolong life expectancy of the compressor, clean the filter on a regular basis by removing the element from the housing, tapping it on a hard surface, exposed side down. This will empty the pleats of the filter of collected dust. If the dust has been wet or will not clean out, call Yetter to order a new element, part number 2940-395. You may lightly blow out the electronic box using an air tool. The housing and filter should be checked every two days of field operation, or more if conditions are very dusty.

### CONNECTIONS



**FAILURE TO LINE UP TABS WHEN PLUGGING MALE INTO FEMALE CONNECTORS CAN RESULT IN SHORT CIRCUIT. ALSO CHECK TAB AND SLOT SIZES, PLUGGING CONNECTORS IN BACKWARDS WILL RESULT IN FAULTY SYSTEM!!**

# 2940 AIR ADJUST SYSTEM INFORMATION

The 2940 Air Adjust Residue Manager control system consists of five primary components and kits. These parts include; the Cab Controller, the Air Compressor Assembly, Residue Manager (RM) or Residue Manager Coulter Combo Kit, Compressor Mounting Kit and the necessary Wires, Air Lines, and Fittings Kit.

## Cab Controller

### 2940-100 Cab Controller



### 2940-113 Ram Mount



The Cab Controller will use the RAM mount provided for installation in cab. Make adjustments quickly and accurately during planting with the cab controller. Adjust up and down pressure to create the ideal “ride” or floating position for residue managers. Lift and down pressure settings can be adjusted independently. Down pressure can be increased to fix row cleaner in the rigid position if desired. Five presets can be programmed within the controller for quick changes. Residue Managers can be raised as needed with a push of the Roman Numeral I Up button.

## Cab Controller Serial Number

Serial # is located on the back of the Cab control. See photo below.



## VDM Serial Number

Serial # is located on the front of VDM in the compressor assembly. See photo below.

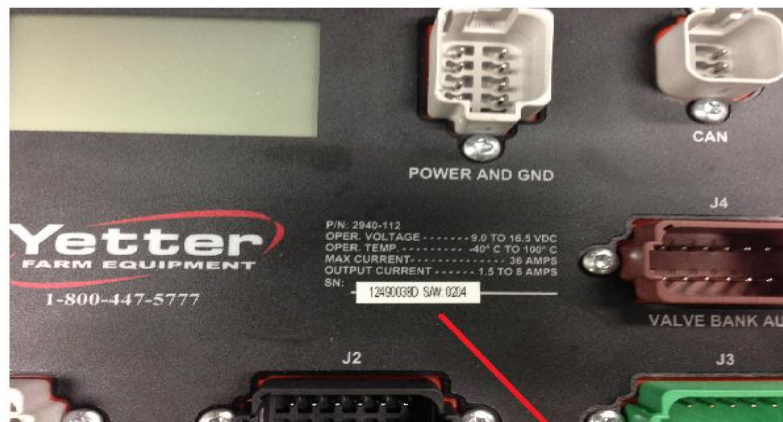

Serial Number Location

# Air Compressor Assembly

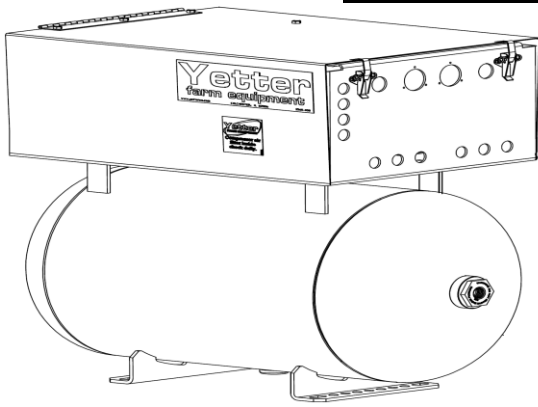

1818-COMPRESSOR ASSEMBLY

2940 Air Adjust requires a stable air supply source that can provide 95psi of clean, dry air. The 'clean, dry air' is a key component of the air supply, moisture within the air supply can shorten the life-cycle of the system.

## 2940-101 External Lay Out

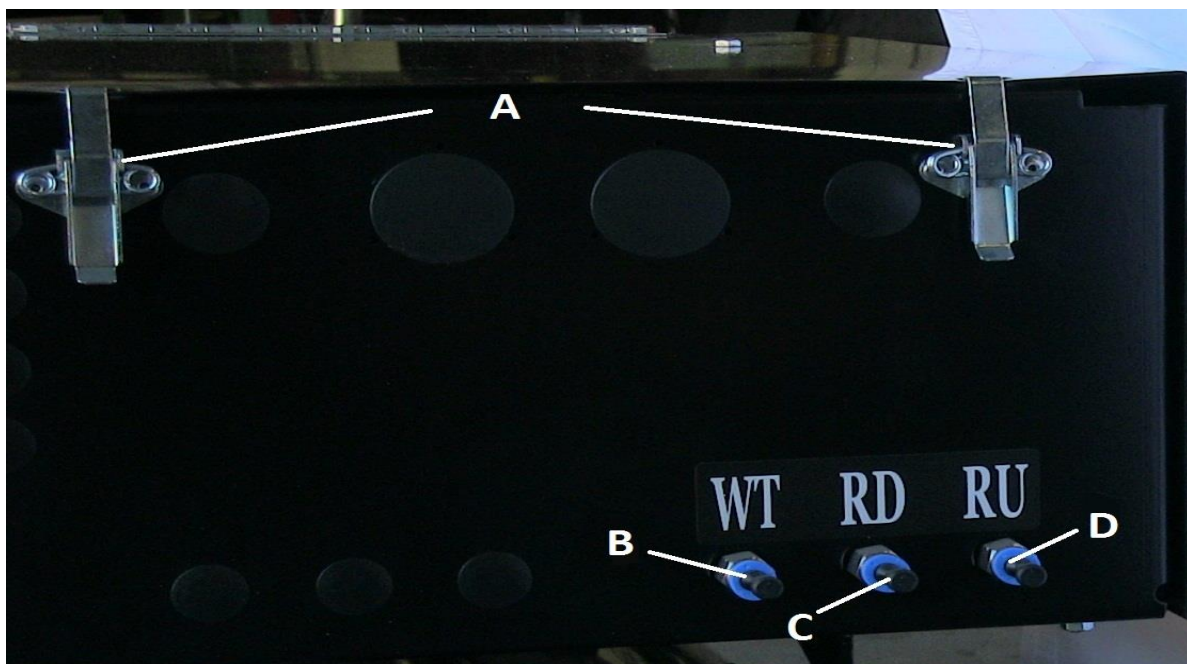

- A. **LATCHES** (2940-307) for closing the air compressor housing lid
- B. **WHEEL TRACK DOWN PRESSURE PORT**- Route black airline from the WT port to the inlet of the down pressure dump valve on the center/wheel track rows of the planter. The down pressure psi on the center RMs or RM/Coulter Combos can be adjusted separately from the wing/side section RM or RM/ Coulter Combos down pressure psi. If the WT port is not used, install the 2940-352 plug to prevent air loss
- C. **RESIDUE DOWN PRESSURE PORT**-Route black airline from the RD port to the inlet of each down pressure dump valve on the wing/side sections of the planter. This port dispenses down pressure to the RM or RM/ Coulter Combos on the wing/side as commanded from the cab controller.
- D. **RESIDUE UP PRESSURE PORT**-Route blue airline from the RU port to the inlet port of the up pressure dump valves on each section (wing/side sections and center/wheel track sections) of the planter. This port dispenses up pressure to each RM or RM/ Coulter Combos on the planter.

# 2940-101 External Lay Out

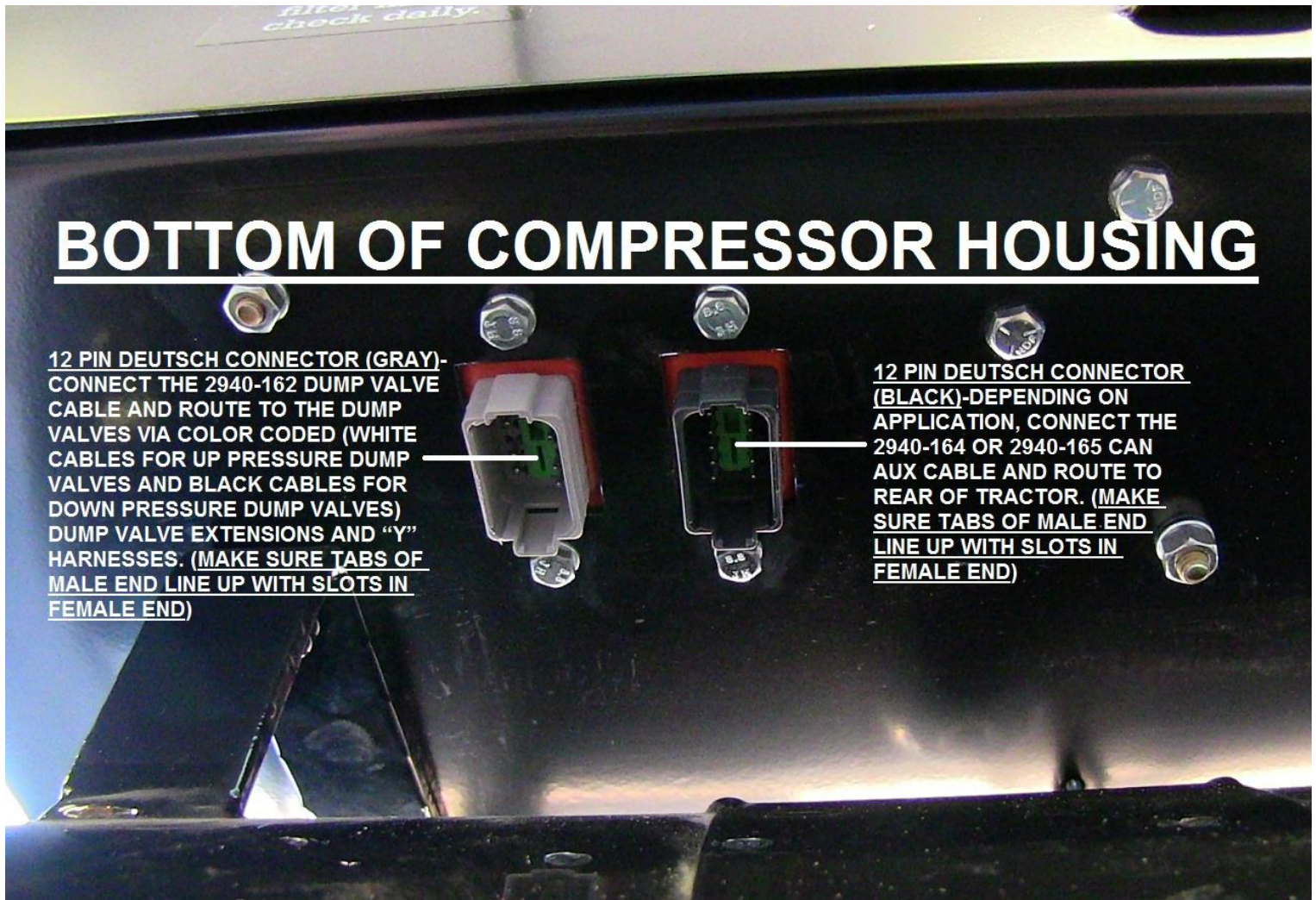
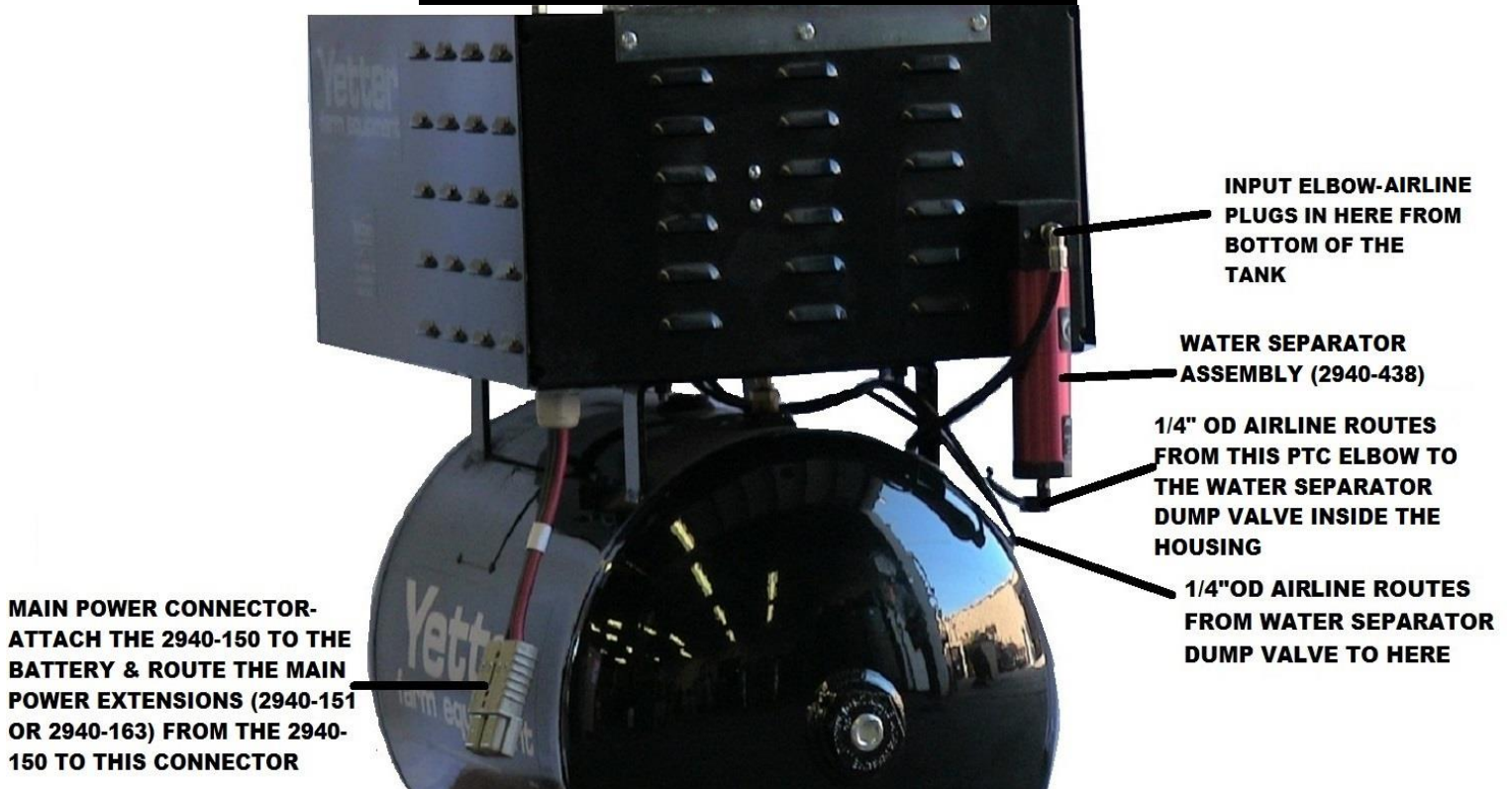

## 2940-101 Internal Lay Out

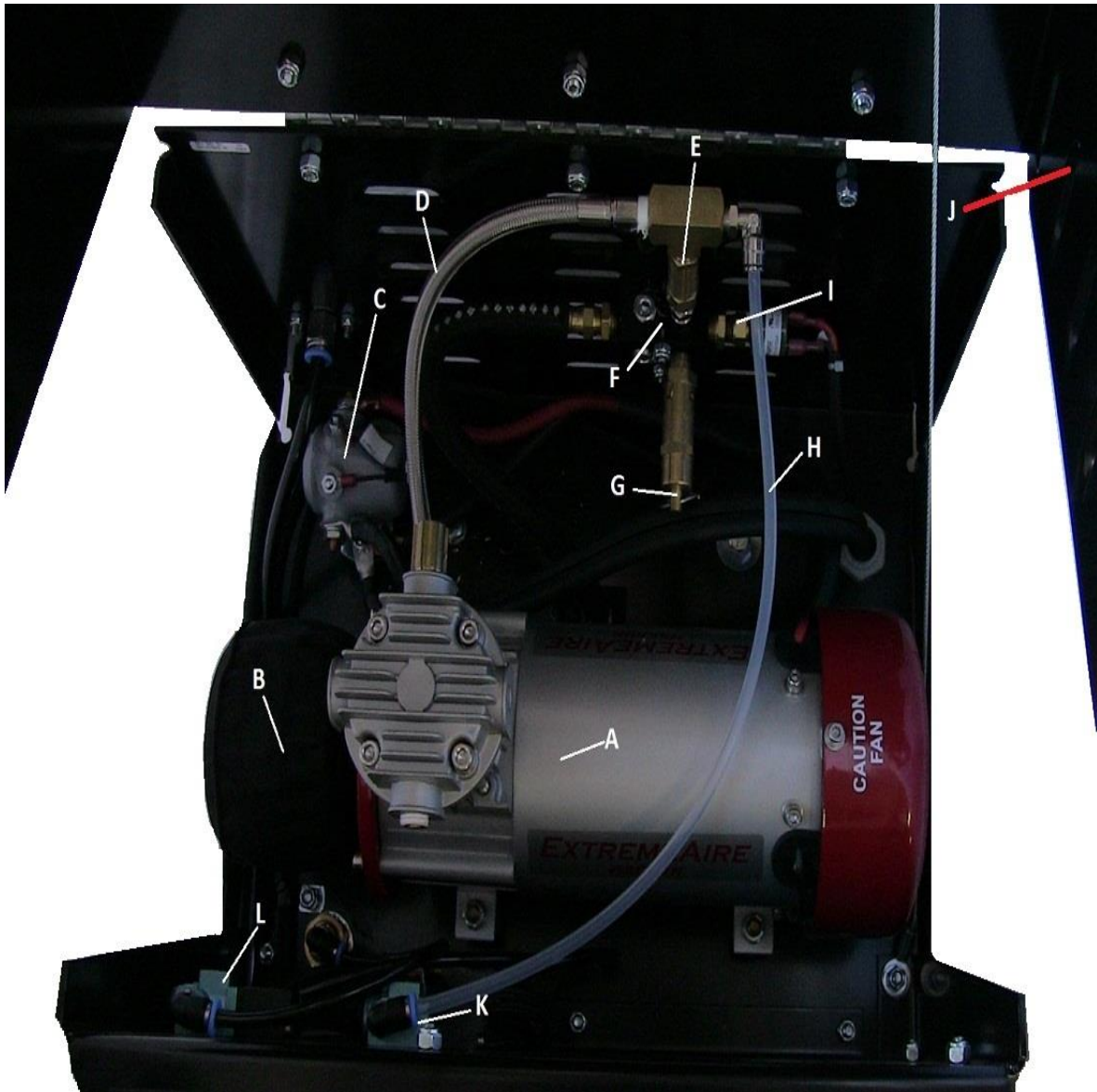

- |    |          |                                    |          |                     |
|----|----------|------------------------------------|----------|---------------------|
| A. | 2940-390 | Air Compressor                     |          |                     |
| B. | 2940-395 | Filter                             | 2940-396 | Pre-Cleaner Element |
| C. | 2940-391 | Relay                              |          |                     |
| D. | 2940-398 | SS Braided Compressor Line         |          |                     |
| E. | 2940-392 | Check Valve                        |          |                     |
| F. | 2940-433 | Compressor Manifold Inlet Assembly |          |                     |
| G. | 2940-416 | Safety Relief Valve                |          |                     |
| H. | 2940-435 | High Pressure Relief Line          |          |                     |
| I. | 2940-393 | Compressor Pressure Switch         |          |                     |
| J. | 2940-143 | Lid                                |          |                     |
| K. | 2940-336 | Head Pressure Relief Dump Valve    |          |                     |
| L. | 2940-336 | Water Separator Valve              |          |                     |

# 2940-101 Internal Lay Out

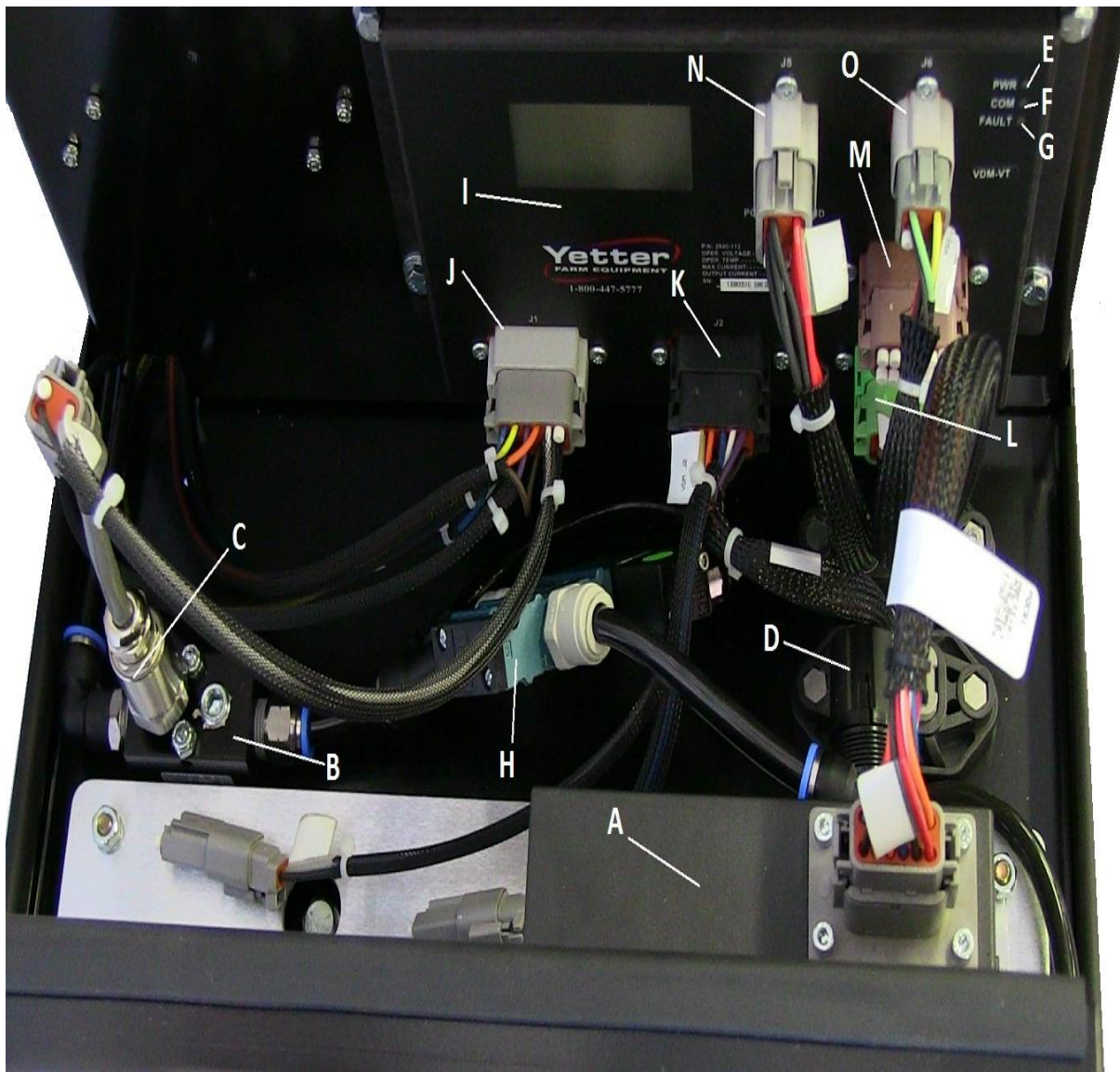

- |              |                                          |
|--------------|------------------------------------------|
| A. 2940-402  | PQE                                      |
| B. 2940-432  | Manifold Inlet Assembly                  |
| C. 2940-441  | Pressure Transducer                      |
| D. 2940-420  | Regulator                                |
| E. No Part # | Power Indicator                          |
| F. No Part # | Communication Indicator                  |
| G. No Part # | System Fault Indicator                   |
| H. 2940-139  | Pressure on Valve                        |
| I. 2940-112  | VDM                                      |
| J. 2940-521  | J1 Port-Transducer/Valve Control Harness |
| K. 2940-522  | J2 Port-Dump Valve Control Harness       |
| L. 2940-524  | J3 Port-PQE Control Harness              |
| M. 2940-525  | J4 Port-PQE 2 Control Port               |
| N. 2940-523  | J5 Port-VDM Power Harness                |
| O. 2940-523  | J6 Port- Communication Control Harness   |

## Residue Manager



Each kit will include the required brackets and hardware to mount the residue managers or residue manager/ coultter combo

## RM/Coulter Combo



## Harness, Airlines, and Fittings Kit



12V-DC cables will be used to power the Compressor, VDM, Cab Controller, and Dump Valves. Flexible tubing will be used to move air from the external ports of the PQE to each air bag. Each kit will include pneumatic lines for both circuits, down and lift, as well as the fittings to make connections and cable ties to securely fasten the lines to the planter. Note: All 2940 Air Adjust kit include a tubing cutter within the kit.

The 2940-341 tubing cutter should be used for every cut to ensure a clean, square cut.



# **2940 Air Adjust Installation Guide Outline**

## **STEP 1: RESIDUE MANAGER OR COULTER/RESIDUE MANAGER COMBO INSTALLATION**

Install the Residue Manager Assembly securing with 2940-142 mounting hardware. When installing the 2940-215 or 2940-216 wheel mount assembly on the adjustment tube of the 2940-190, place the top hole of the wheel mount to the 4<sup>th</sup> or 5<sup>th</sup> hole from the top of the adjustment tube for conventional tillage or mellow soils. For no-till/minimum-till operations, install the wheel mount on the 5<sup>th</sup> or 6<sup>th</sup> hole from the top. Install wheels on wheel mounts using the 2966-119 bolt bag. If application is RM/Coulter combo, install the 2940-191 assembly using the 2940-187 bolt bag. Mount the coulter blade on the coulter arm hub, mount the coulter arm to the 2940-191 assembly, and mount the RM wheels using the 2966-119 bolt bag **Refer to the diagrams on pages 17-20**

## **STEP 2: INSTALLING 2940-100 CAB CONTROLLER**

Install the 2940 Air Adjust Cab Controller by mounting the 2940-133 to the operating tractor's monitor mounting system. Install 2940-100 Cab Controller to the 2940-133 RAM Mount. Position the Cab Controller within reach during operation without compromising safety or visibility from the cab. Connect the 2940-152 harness by connecting the 6 pin connector to the cab controller and routing the black CAN connector towards the hitch of the tractor. Connect the 2940-153 2 pin connector to the cab controller and the red and black wires to the appropriate connector to fit the tractor power source. **Refer to the diagram on page 21**

## **STEP 3: INSTALLING COMPRESSOR ASSEMBLY**

Begin by locating a suitable mounting location for the compressor assembly. Placement of the compressor assembly will vary on the make and model of the planter. Use mounts supplied or depending on application, **different mounts may need to be built**. NOTE: Be sure to check clearance of compressor assembly in all locations, especially noting tractor tires during turns, folding/unfolding the planter for transport mode, and 2-point top link. **Refer to the diagram on pages 22-23**

## **STEP 4: COMPRESSOR POWER SUPPLY CABLES AND HARNESS INSTALLATION**

Install the 2940-150 main power cable with 80 amp breaker **AND** 2940-166 VDM power with 40 amp breaker on the correct battery terminals (red is positive+ and black is negative -). Next, connect the appropriate length of main power extensions (2940-151 or 2940-163) off of the 2940-150, route to large Anderson power connector coming out of the bottom of the 2940-101 compressor assembly housing, & install. Install the appropriate length VDM power extension (2940-167 or 2940-168) off of the 2940-166, route to the hitch of the tractor to install into the matching connector on the CAN Aux to Air Harness. Lastly, install the appropriate length CAN Aux to Air Harness, 2940-164 or 2940-165. The smaller Anderson power connector that connects to the VDM power extension, the black Can connector connects to the other black CAN connector that routes to the cab controller, & the black male 12 pin Deutsch connector connects to the black female end on the bottom of the 2940-101 compressor assembly housing. 2940-170, 2940-171, or 2940-430 CAN Aux to Air Extensions may be necessary if 2940-101 compressor is mounted further back on the planter than the hitch. The compressor must be mounted within 50 feet of power cable length of the operating tractor's battery. If over 50 feet, heavier than 4 gauge power cables must be built. **Refer to the diagram on page 24**

## **STEP 5: DUMP VALVE INSTALLATION**

Install the dump valves to the planter as shown in the diagram that matches the planter. 16 row planters and less will have 1 up pressure and 1 down pressure dump valve per wing/side section of the planter and 1 up pressure and 1 down pressure dump valve for wheel track rows. 24 row planters and larger will have 3 dump valves per wing, 2 for down pressure and 1 for up, and 2 on the wheel track, 1 for up pressure and 1 for down pressure. Split row planters will vary. **Refer to pages 25, 27-57**

## **STEP 6: CONNECTING & ROUTING AIR LINES**

Start by routing black (down pressure) and blue (up pressure) airline on each wing or side of the planter. A group of airlines that route to the row cleaner air bags are referred to as trunk lines. When plumbing in the WT (wheel track) rows, use the center 6 rows that plant over the tractor and planter wheel tracks. If equipping on a narrow transport planter with 4 center rows, tie in the one row on each wing/side of the planter closest to the last & first center row. The airline routing from the RU, RD, & WT ports to the inlet of the dump valve for the matching circuit is referred to as a Supply airline. Use the supplied tees to make enough open ports in each circuit to install supply airline to the inlet port of each dump valve of the matching circuit. Also use tees to connect the outlet port of the dump valves to the matching circuits of the trunk airlines. **Refer to the diagrams on pages 26-59**

## **STEP 7: PERFORM A PRE-OPERATION TEST OF THE SYSTEM**

Now that the system is installed, perform a pre-operation test. Start by folding and unfolding and lowering and raising the planter to check for enough slack in airline & in harnesses at hinge points. Check all electrical connections, cables, and airline making sure nothing was damaged. Next, turn on the cab controller by holding the power button. After the cab controller is on, turn all pressures (RU, RD, WT) to 0psi and press enter to actuate the system. The compressor will turn on and build to 95psi and turn off. Check the interior of the housing (PQE, Pressure on Valve, & airline within the housing) for leaks. Apply 30psi to the RU port and watch your row cleaners as they should all rise to maximum up travel. Check for leaks on all up pressure circuits and fittings. When that leak check is finished, turn RU to 0psi & turn RD and WT to 30. Check all down pressure airline and fittings in these circuits for leaks and repair as needed. **Refer to page 66-67**



# Residue Manager(RM) Installation



**CAUTION: ENGAGE THE CYLINDER STOPS ON THE PLANTER LIFT WHEELS TO "LOCK" THE PLANTER IN THE UP/ROAD TRAVEL POSITION**

## Installation overview:

- Prior to installing check the freedom of motion of the row cleaner.
- The installation process should be done with the planter raised, half folded for transport, and the row units fully extended down.
- Install the 2940 RM or RM/Coulter Combo Mounting Bracket Assembly centered on the planter row unit with provided hardware.

## For John Deere, Kinze, and White Models Installing RM Only

**Step 1:** Mount the 2940-190 Pneumatic RM mount assembly using 3) 1/2"X1-1/2" GR5 bolts, 3) 1/2" flat washers, and 3) 1/2" lock nuts. Use diagram below for mounting hole alignment.

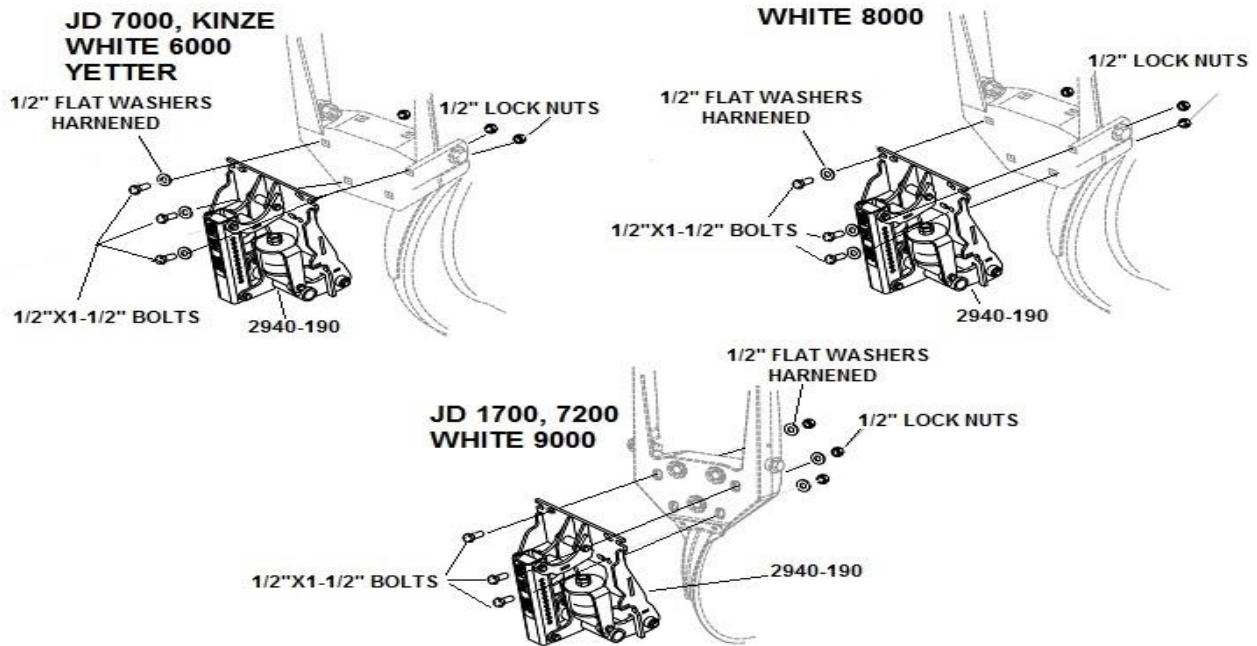

## For Case Models Installing RM Only

**Step 1:** Mount the 2940-209 CNH adaptor bracket to the row unit attachment casting using 2) 1/2"X3-3/4" bolts and 2) 1/2" lock nuts. Attach the 2940-190 to the 2940-209 using 3) 1/2"X1-1/2"GR5 bolts, 3) 1/2" flat washers, and 3) 1/2" lock nuts.

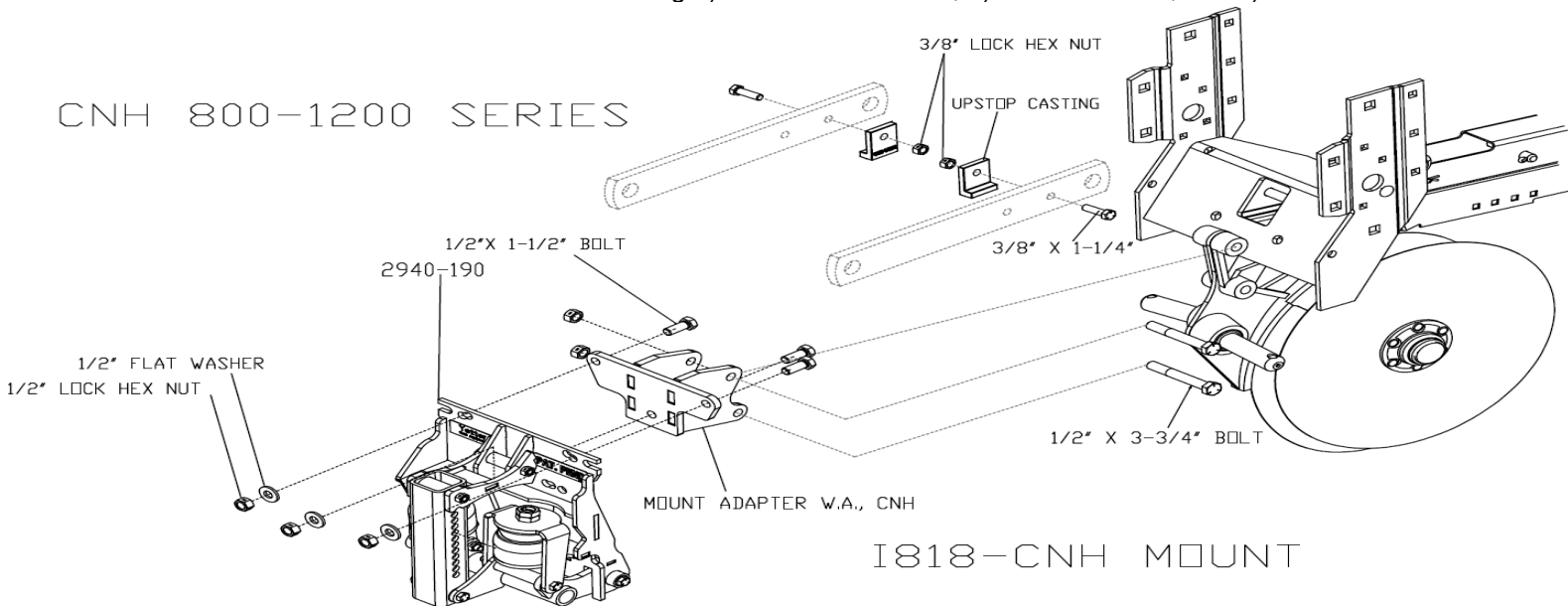

# Residue Manager Installation

**Step 2:** Mount the 2940-215 or 2940-216 wheel mount W.A. on the adjustment tube of the 2940-190. Recommended mounting location is 5<sup>th</sup> hole down from the top of the adjustment tube mounts to the top hole of the wheel mount W.A. Adjustments may need to be made depending on tillage practice, soil conditions, and/or residue thickness.

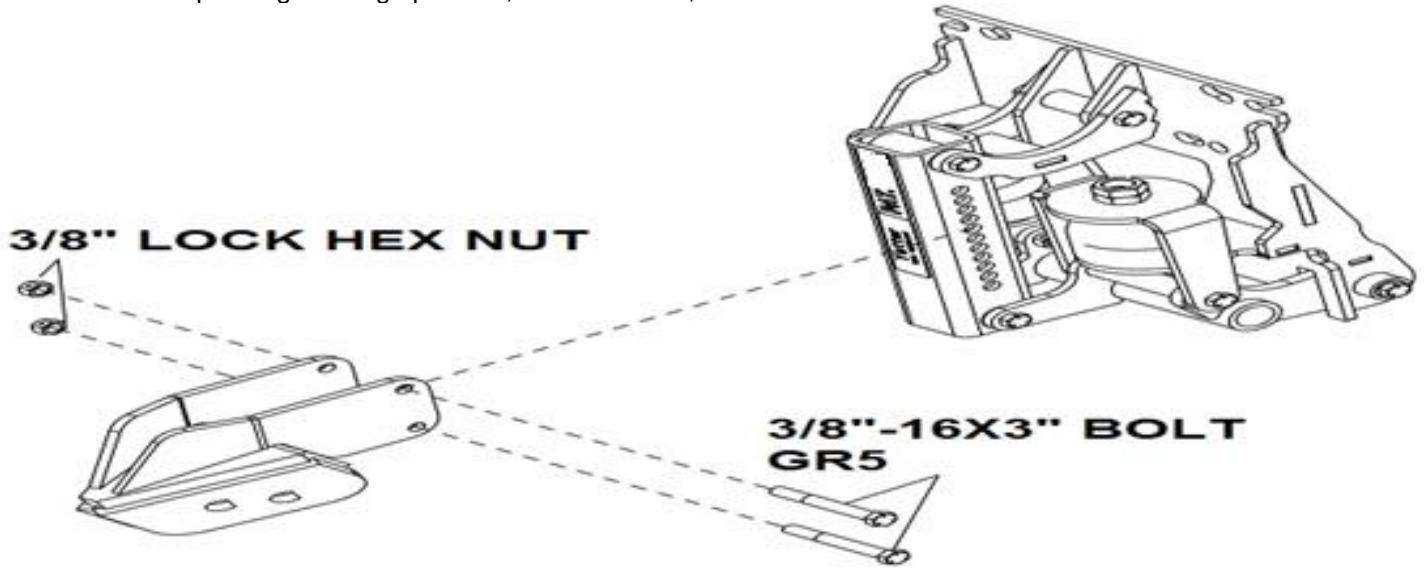

**Step 3:** Mount the RM wheels on the wheel mount using 2) 5/8" lock washer and 2) 5/8 hex nut. Mount the wheels so the left side of the planters has the left wheel leading and the right side of the planter has the right wheel leading. Right and left is determined by standing behind the planter looking at the tractor. Properly install row cleaner wheels so that wheel teeth point up when entering field debris.

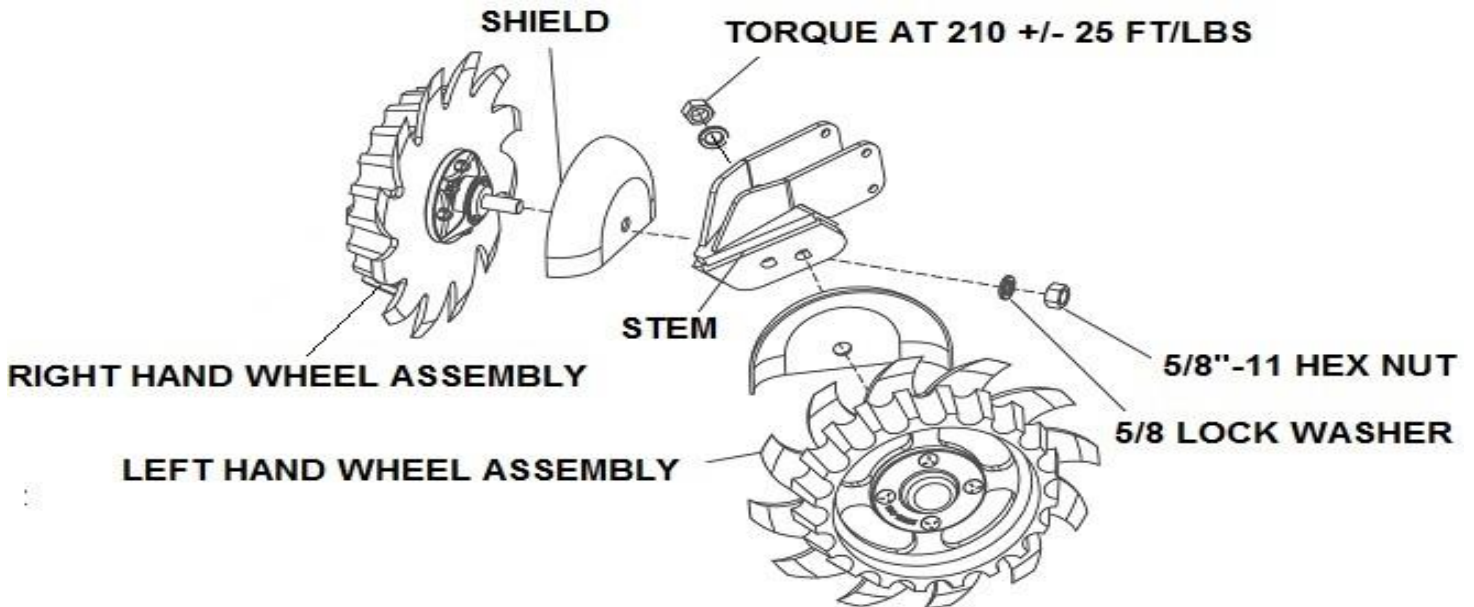

## **1818-D-BOLT TORQUE**

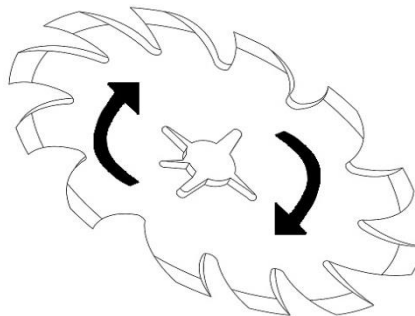

## **2940-010 RM/Coulter Combo Installation**

**Step 1:** Mount the 2940-191 assembly to the row unit face plate using 3) 1/2"X1 1/2 bolts and 3) 1/2" lock nuts.

**1/2" BOLTS AND 1/2" LOCK NUTS  
ARE USED TO MOUNT TO ROW UNIT**



**Step 2:** Make sure elbows swivel by placing 11/16" wrench on NPT end and turning elbow by hand a few rotations. Once fittings are started on the air bag, tighten until thread tape almost disappears. **OVER TIGHTENING WILL STRIP THREADS & CAUSE AIR LEAK!**

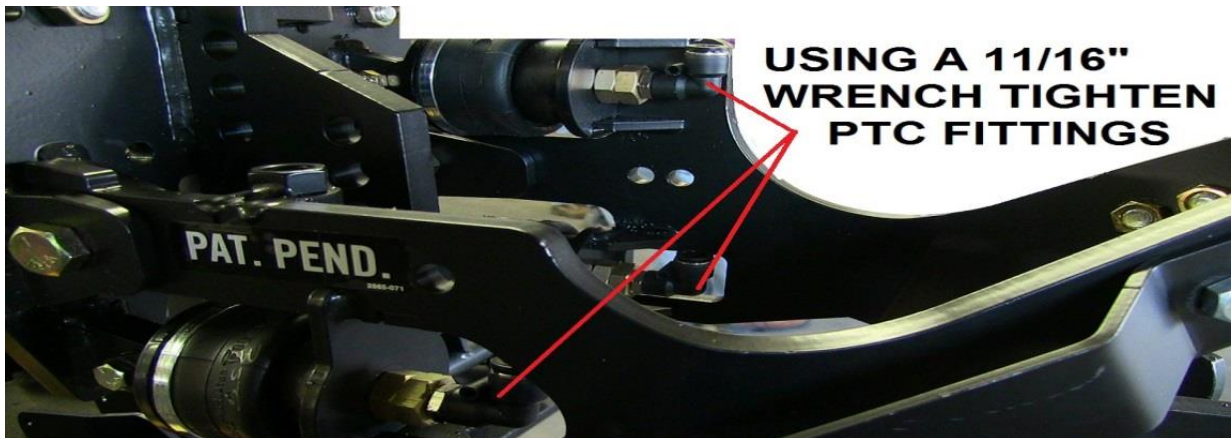

**Step 3:** Install coultter blade using 4) 1/2"X1 1/4" carriage bolts. The blade **MUST** be installed on the hub before mounting the coultter arm assembly. **IF USING SETTING #2 ON CHART ON PAGE 20 FOR COULTTER DEPTH, LEAVE THE BLADE LOOSE ON THE HUB IN ORDER TO INSTALL COULTTER ARM. DOING SO ALLOWS THE COULTTER ARM MOUNTING BOLT CLOSEST TO THE HUB TO BE INSERTED IN STEP 4 WITHOUT CLEARANCE ISSUES.**



**ASSEMBLE BLADE AND HUB  
RETAINER TO HUB USING 1/2"  
CARRIAGE BOLTS, LOCK WASHERS,  
AND HEX NUTS**

# 2940-010 RM/Coulter Combo Installation

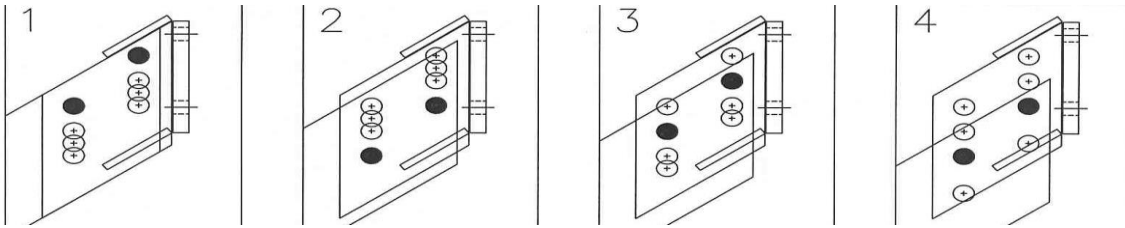

**THIS IS A REFERENCE GUIDE TABLE. ALL MEASUREMENTS WERE TAKEN WITH THE ROW UNIT AND PLANTER FRAME LEVEL/PARALLEL TO THE SURFACE.**

## USING A 16" COULTER BLADE

15" PLANTER BLADES	15" PLANTER BLADES
JD 7000 AND KINZE PLANTERS	JD 1700, 7200, & 7300 PLANTERS
ALL WHITE 6000 PLANTERS	PRO AND PLUS SERIES
BOLT POSITION #	BOLT POSITION #
1) 1-1/2" ABOVE SEED DEPTH1)	1" ABOVE SEED DEPTH
2) 1" ABOVE SEED DEPTH	2) 5/8" ABOVE SEED DEPTH
3) 1/2" ABOVE SEED DEPTH	3) EVEN WITH SEED DEPTH
4) 1/2" BELOW SEED DEPTH	4) 7/8" BELOW SEED DEPTH

**STEP 4:** Install coulter and arm assembly in desired setting using 2) 5/8"x2" bolts and 2) 5/8" hex jam locknuts. Pull arm up when tightening to allow more space between coulter blade and disc opening blades.

## MOUNT COULTER ARM USING 5/8 BOLTS AND NUTS.

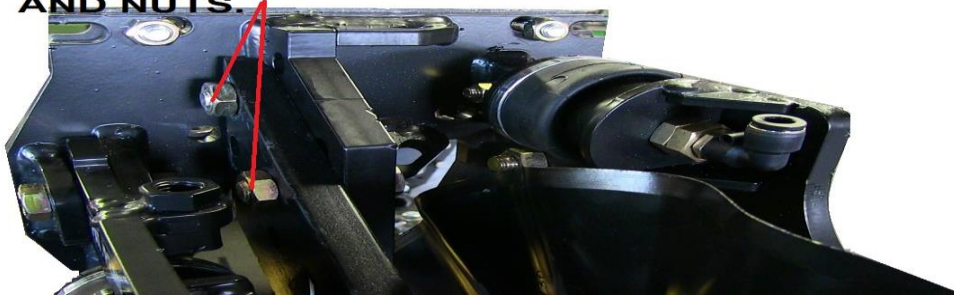

**Adjustment:** Adjust coulter blade depth equal to or above the planter disc opener blades. Adjust the coulter blade depth as required for planter disc opener blade wear. Planter double disc blades that are worn to 14 1/4" or smaller in diameter should be replaced. Example: 14 1/4" blades will have a 3/8" shallower planting depth than 15" blades at the same gauge wheel adjustment setting.

**STEP 5:** Install 5/8" jam nut on the 5/8"x3" square head down stop bolt. Set down stop to desired setting, then tighten jam nut to hold stop bolt in place.

## INSTALL DOWN STOP BOLT AND JAM NUT AT DESIRED DEPTH

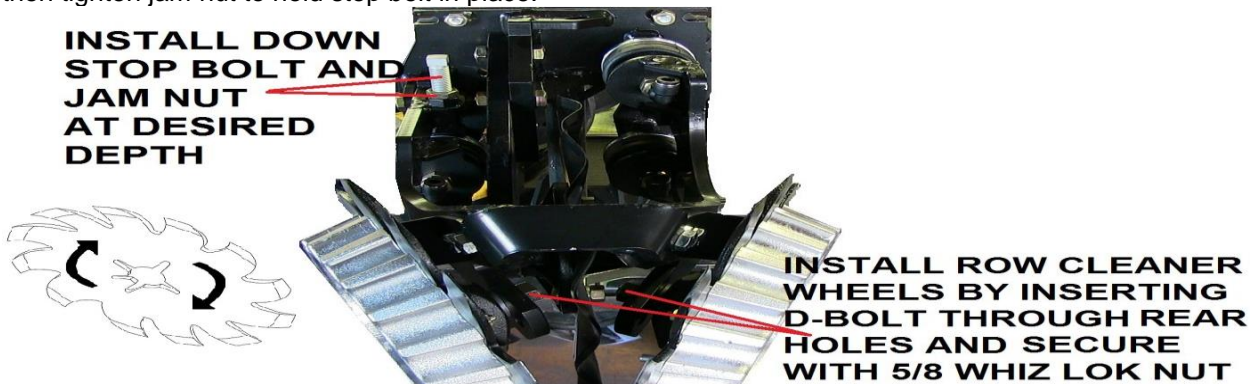

**STEP 6:** Install RM wheels by sliding 5/8" D-bolts through the rear mounting holes on each side of the arm. Install the row cleaner wheels so that wheel's teeth point up when entering field debris.

# Cab Controller Installation



**Step 1:** Begin installing the 2940 Air Adjust controller once an adequate mounting location has been found. Fix the base component of the 2940-113 Mounting Bracket in place. Use items labeled B if mounting to a slotted flat mounting system or items C if using a tubular mounting system. 2 different sized U-bolts are provided for tubular mounting systems.

**Step 2:** Connect the mount bracket to the rear of the controller using 4) M5 Hex Nut and 4) M5 split washers labeled A in picture above.

**Step 3:** Attach the male end 2 pin connector of the 2940-153 to the female end 2 pin connector on the 2940-100 cab controller. Install connector not provided for your tractor at the bare end of the 2940-153 and connect to tractors switched power source. **The cigarette outlet is NOT a switched power source on all models of tractors, and therefore should not be used.**

**Switched Power Source Connector part #'s:**

**JOHN DEERE PART #: RE67013**

**CNH PART #: 187103A1**



**Step 4:** Route & install the 2940-152 hitch to switch panel wire harness from the rear 6 pin connector of the 2940-100 cab controller to the hitch-point at the rear of the tractor. The black CAN connector of the 2940-152 will connect to the 2940-164 or 2940-165 CAN Aux to Air Harness. (See page 24 for further details)



# INSTALLING 2940 AIR COMPRESSOR ASSEMBLY

**Step 1:** Every planter/tractor combination will contain its own unique situations in regard to mounting the 2940 Compressor Assembly for clearance and accessibility. **YOU SHOULD EXERCISE YOUR OWN BEST JUDGEMENT TO FIT YOUR SITUATION.** Begin by locating a suitable mounting location for the compressor assembly. Placement of the compressor assembly will vary on the make and model of the planter. Use mounts supplied or **depending on application different mounts may need to be built.** NOTE: Be sure to check clearance of compressor assembly in all locations, especially noting tractor tires and folding/unfolding the planter for transport mode and 2-point top link.

**Step 2:** Visually inspect the proposed mounting location for structural stability and to find signs of wear in that location. Possible obstructions to be aware of include marker arms, liquid fertilizer tanks, rear tires (duals especially) during tight turns, 2 point top link, etc...

**Step 3:** Mark out the position of the Compressor then complete a cycle of folding/unfolding to transport mode and raising/lowering of the planter; as well as, driving in a tight circle in one or both directions, in planting position, to verify or identify obstructions.

**Step 4:** Once the compressor is mounted, repeat the previous process very cautiously to once again verify that the compressor is clear of obstructions.

Use the illustration with dimensions to identify possible mounting locations on your specific planter. The 2940-101 require 4" of clearance from each side. (top, bottom, front, back, both sides)

Always mount the compressor in the vertical position, housing above the tank.

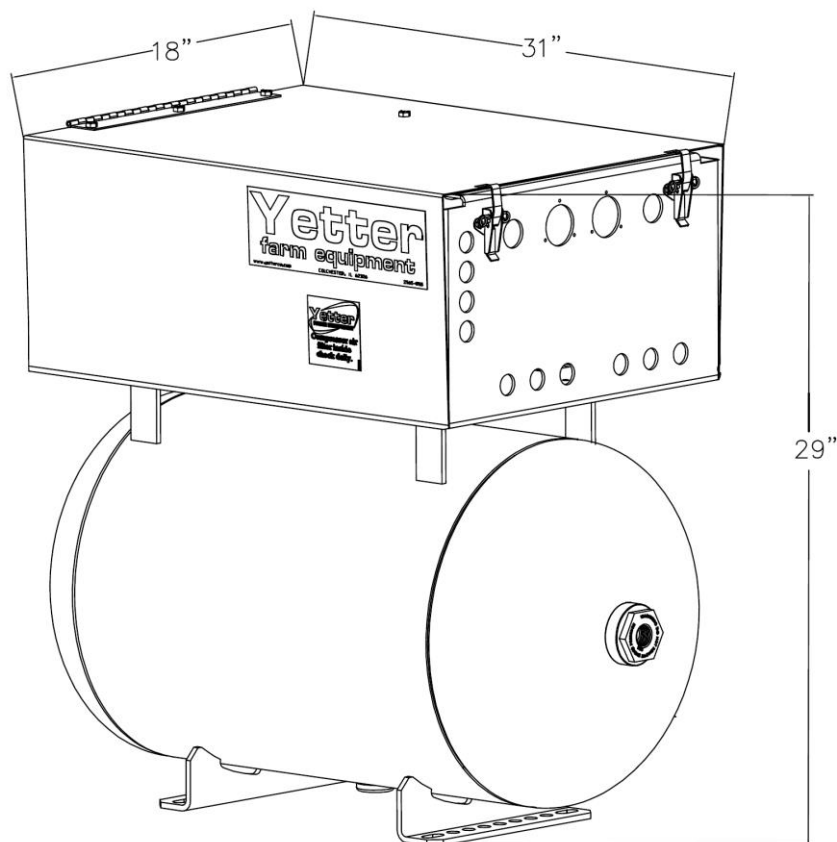

1818—COMPRESSOR DIMENSIONS

# 2940 Electric Compressor Installation

1818-09

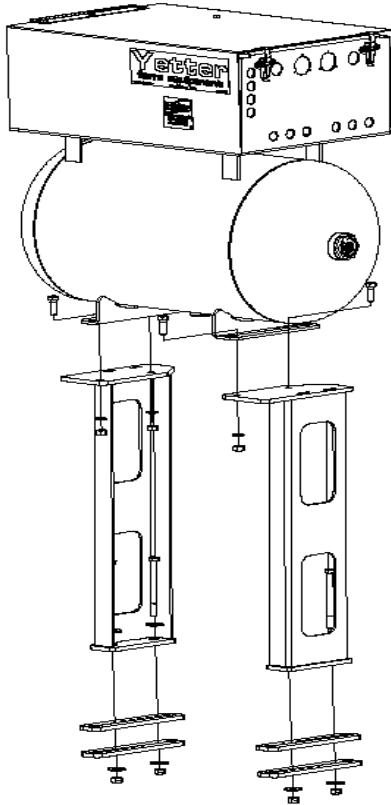

2940-085 2 point  
or universal  
compressor  
mount kit

2940-085 mounting kit is designed for mounting to the 2 point cross hitch on the planter, or require greater elevation of the compressor for clearance reasons.

1818-010

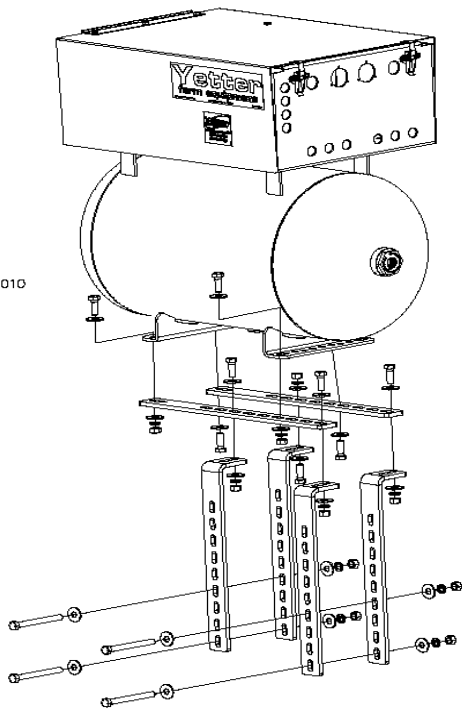

2940-086 draft tube or  
universal mount kit (placement  
of compressor may vary for  
each planter make and model)

The most common mounting location for larger planters will be on the draft bar. Use the 2940-086 mounting kit for situations that require mounting elsewhere on the planter than the hitch. This will allow the compressor to be elevated and set back (or forward) to avoid clearance issue.

**Refer to pages 83 and 84 for Part Identification.**

**In some situations, mounting brackets may need to be built to fit your planters set-up.**

# Compressor Power Cable and Harness Installation

**Step 1:** Install the 2940-150 main power cable with 80A breaker and the 2940-166 VDM power cable with 40A breaker on the operating tractor's battery. Red cable installs on the positive (+) battery terminal post and the black cable installs on the negative (-) battery terminal post.



**Step 2:** From the Anderson connector of the 2940-150, safely route and install the appropriate length of main power extension cables, part numbers 2940-151 is a 10ft main power extension and 2940-163 is a 20ft main power extension, into the Anderson connector that comes out of the bottom of the compressor housing. If operating tractor is articulating or if compressor is further back on the planter than the hitch, more extension cables may be needed. **Cable length from the battery to the compressor should not exceed 50 feet. Longer than 50 feet distances cause the 80A breaker to become weak and trip often. If distance is greater than 50 feet, heavier cable needs made using 0 or 2 gauge wire.**



**Step 3:** From the Anderson connector of the 2940-166, safely route and install the appropriate length of VDM power extension cables, part numbers 2940-167 is a 10ft VDM power extension and 2940-168 is a 20ft VDM power extension, to the hitch of the tractor. Route VDM extensions so that the end at the hitch of the tractor ends up close to the black CAN connector that routes from the back of the cab controller to the hitch of the tractor.



**Step 4:** Install the 2940-164 5ft CAN Aux to Air harness or 2940-165 10ft. CAN Aux to Air harness. The black CAN connector connects to the other black CAN connector that comes from the cab controller. The small Anderson connector connects to the VDM power extension that routes to the battery. The male black 12 pin Deutsch connector installs into the black female 12 pin Deutsch connector located on the bottom of the compressor housing. If the compressor assembly is located further back on the planter than the hitch, CAN Aux to Air extension harnessing may need to be purchased. 2940-170 is 10ft CAN Aux to Air extension, 2940-171 is 30ft CAN Aux to Air extension, and 2940-430 is 20ft CAN Aux to Air extension.





# 2940 -136 Dump Valve Installation

**Step 1**-Align the holes on valve(8) with mounting plate(3) holes. Insert bolts(5) through the aligned holes and start nut(4) on the threads. Tighten nut with ¼" wrench while holding bolt with a phillips screwdriver until tight.

**Step 2**-Install supplied 6" piece of black airline(6) in port 1, the vent elbow(7).

**Step 3**-If install is on a John Deere planter, use flat flanged nut(1) to install Dump Valve assembly. If install is on any other model of planters, use the serrated flanged nut(2) for the install of the dump valves. Install Dump Valve by placing circle cut out on mounting tab(3) on U-bolt used to mount the row unit to planter toolbar. Pinch mounting tab(3) between existing nut on U-bolt and the provided flanged nut(1 or 2).

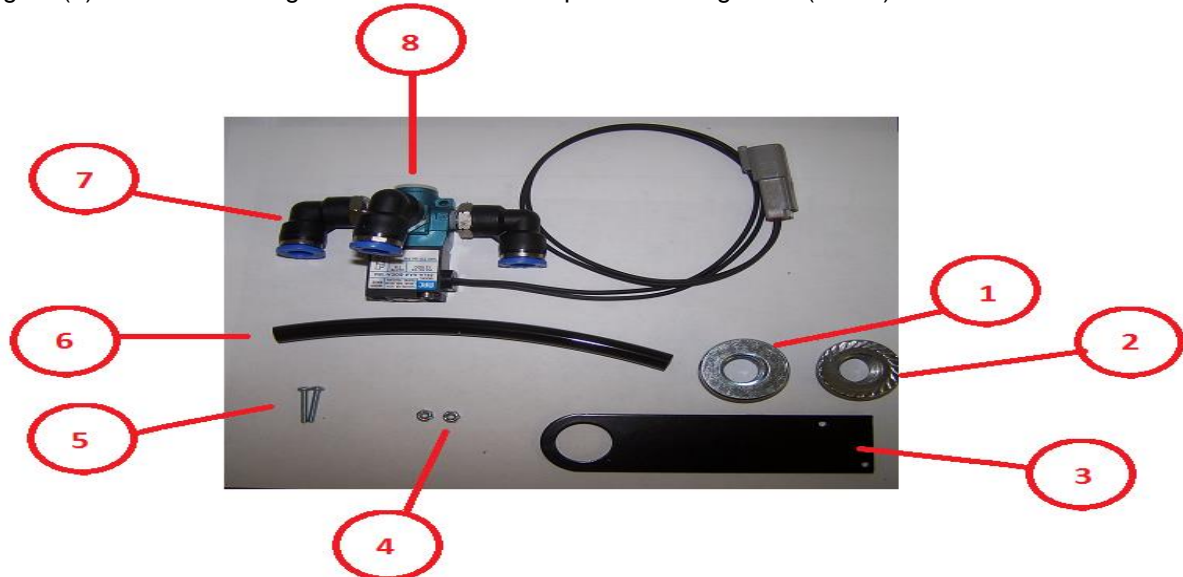

The picture below on the left is an example of how to mount a dump valve to a row unit. The picture below on the right is an example on how to mount 2 dump valves on 1 location.



## Airline Routing-Planter Frame

Below is a suggested method for safely and securely routing the airlines on the planter frame whether installing trunk airlines (airlines that route to the air bags of the row cleaners) or the supply airlines (airlines that route from the 2940-101 compressor housing to the inlet port of the dump valves). Safely route the airlines on the frame that the row units are mounted to. After airline & dump valve harnessing is complete, use provided zip ties to keep parts away from pinch & wear points.



## Air Line Routing-Row Unit

Below is a suggested method for safely and securely routing the air lines from the air bag to tee's on the planter frame. These are generalizations and **YOU SHOULD USE YOUR OWN BEST JUDGEMENT** in routing air lines.

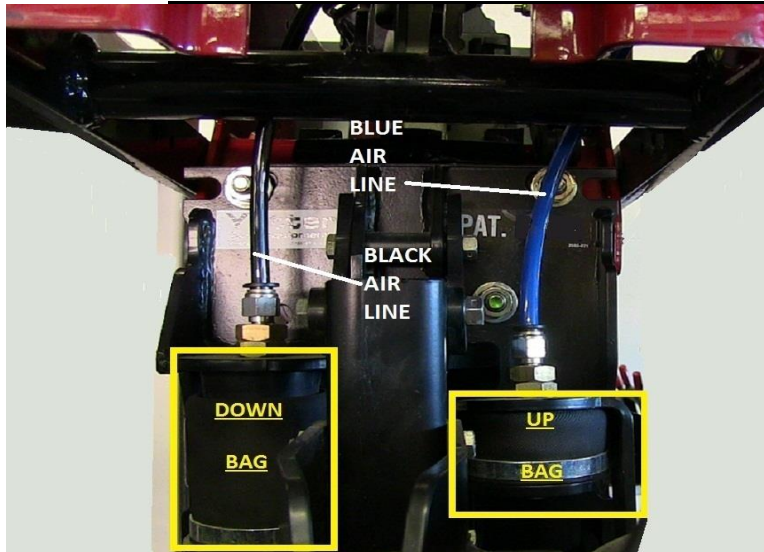

Specific air line routing will be dependent upon:

- \* Row unit make (JD, Kinze, CNH, AGCO, etc)
- \* Parallel arm length

DO NOT pass the lines between the rear of the parallel arm and the row unit. This can act as both a pinch point and wear point. Use provided zip ties to keep airlines away from pinch points, rotating objects that may cause wear, or sharp objects that may cut the airline.

## Air Line Routing

**The following pages are diagrams of the Air lines for various planter makes and models**

Direction of flow is: from Supply Tank to Lift (Blue) and Down (Black) airlines to air bags. All airlines will be 3/8". Route the lines as efficiently and conveniently as possible. Use the airline colors to differentiate the lift pressure (Blue Air Line) and down pressure (Black Air Line) on the planter for trouble shooting, leak detection, & dump valve circuit indication. **If there is no diagram for your situation, contact a Yetter service representative (800-447-5777) and a drawing will be made.**

# 6 Row Dump Valve Diagram

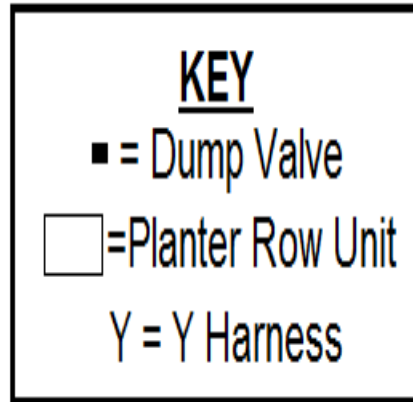

## Down Pressure Dump Valve

### Row

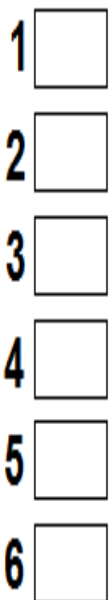

Routes to the 2 pin pigtail labeled RM DOWN DUMP



**Step 1:** Install 1 dump valve on row 3 & 1 dump valve on row 4.

**Step 2:** Install the male 12 pin Deutsch connector of the 2940-162 dump valve cable into the **GRAY** female connector on the underside of the 2940-101 compressor housing.

**Step 3:** Install the mating 2 pin connector of the 2940-156 black dump valve cable to the dump valve on row 3 & route the other end of the 2940-156 to the 2 pin connector labeled RM DOWN DUMP on the 2940-162 from step 2 & install.

**Step 4:** Install the mating 2 pin connector of the 2940-157 white dump valve cable to the dump valve on row 4 & route the other end of the 2940-157 to the 2 pin connector labeled RM UP DUMP on the 2940-162 from step 2 & install.

## Up Pressure Dump Valve

### Row

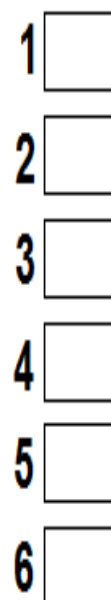

Routes to the 2 pin pigtail labeled RM UP DUMP

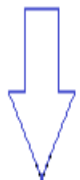

**★ Aux 3 & Aux 4 on 2940-162 are not yet used ★**

# 6 Row Airline Diagram

Down Pressure  
Black Airline  
Row

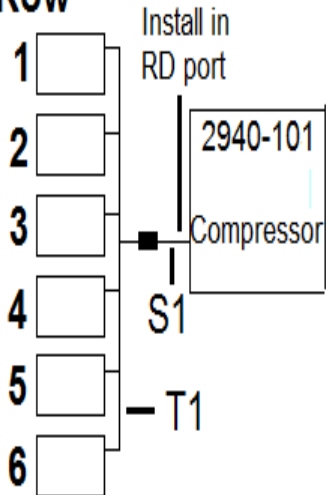

**Step 1: T1 & T2** Route blue & black line from row 1 to row 6. Install the black airline in the down pressure (larger) air bag & the blue airline in the up pressure (smaller) air bag. Trace both airlines back to row 1 installing tees in each (blue & black) airline at each row unit. From each tee in the up pressure (blue airline) circuit, route blue airline to the up pressure air bag and install in the fitting. From each tee in the down pressure (black airline) circuit, route black airline to the down pressure air bag and install in the fitting. When back to row 1, cut each airline to length & install each airline into the matching air bag.

**Step 2:** On row 3 at the down pressure dump valve, install a tee in the black airline installed in step 1. Install black airline from the open port on the tee to the outlet port on the dump valve.

**Step 3:** On row 4 at the up pressure dump valve, install a tee in the blue airline installed in step 1. Install blue airline from the open port on the tee to the outlet port of the dump valve.

**Step 4: S1** Route & install black airline from the RD port in the 2940-101 compressor housing to the inlet port on the down pressure dump valve on row 3.

**Step 5: S2** Route & install blue airline from the RU port of the 2940-101 compressor housing to the inlet port of the up pressure dump valve on row 4.

**Step 6:** Install a plug (2940-352) into the WT port on the 2940-101 compressor housing to prevent air loss. Another way to do this is to cut a 6inch piece of black airline, install one end into the WT port, fold the airline over causing a kink, & zip tie the airline to stay like this. This circuit will not be used with this size of planter.

Up Pressure  
Blue Airline  
Row

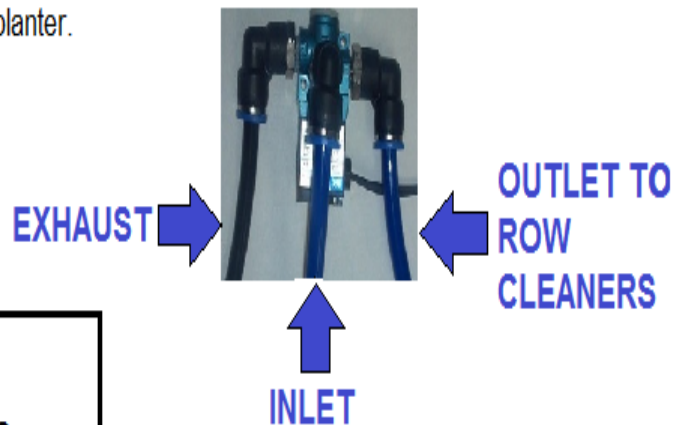
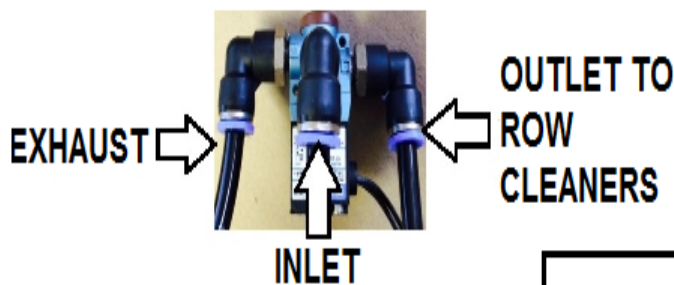
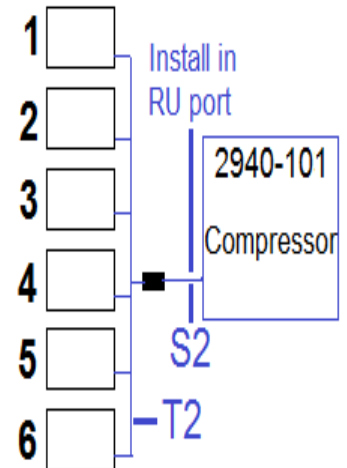

**KEY**

- = Dump Valve
- = Planter Row Unit
- T1-2 = Trunk Line
- S1-2 = Supply Line

# 6/11 or 6/12 Split Row Dump Valve Diagram

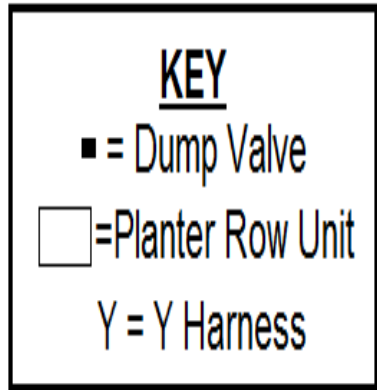

Down  
Pressure  
Dump Valve  
Row

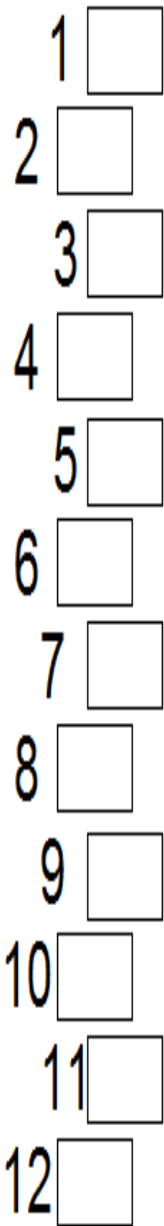

Routes to the 2  
pin pigtail labeled  
RM DOWN DUMP

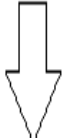

**Step 1:** Install 1 dump valve on row 6 and 1 dump valve on row 7.

**Step 2:** Install the male 12 pin Deutsch connector of the 2940-162 dump valve cable into the **GRAY** female connector on the underside of the 2940-101 compressor housing.

**Step 3:** Route & install the appropriate length of black dump valve cable(s) from the open 2 pin connector of the dump valve on row 6 to the 2 pin connector labeled RM DOWN DUMP on the 2940-162 harness installed in step 2.

**Step 4:** Route & install the appropriate length of white dump valve cable(s) from the open 2 pin connector on the dump valve on row 7 to the 2 pin connector labeled RM UP DUMP on the 2940-162 harness installed in step 2.

Up  
Pressure  
Dump Valve  
Row

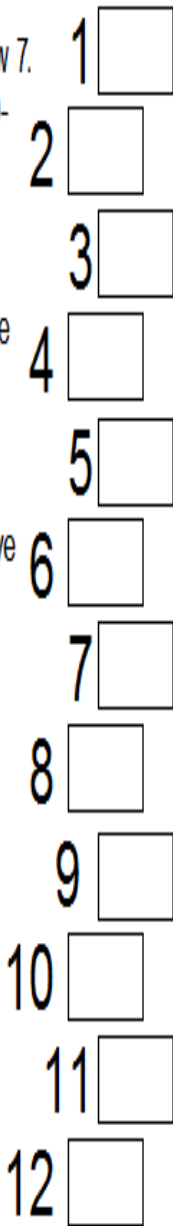

Routes to the 2  
pin pigtail labeled  
RM UP DUMP



**★ Aux 3 & Aux 4 on 2940-162 are not yet used ★**

# 6/11 or 6/12 Split Row Airline Diagram

Down Pressure  
Black Airline  
on corn rows

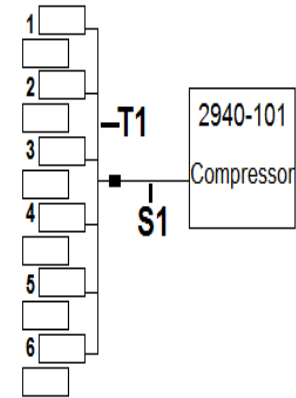

Down Pressure  
Black Airline  
on split rows

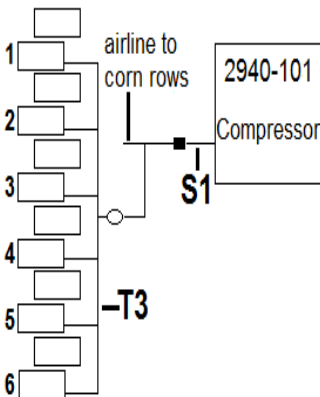

**KEY**

- = Dump Valve
- = Ball Valve
- = Planter Row Unit

S1-2 = Supply Airline  
T1-4 = Trunk Airline

**Step 1: T1 & T2** Route black & blue airline from the first corn row to the last corn row. Install the black airline in the fitting of the down pressure (larger) air bag & the blue airline in the fitting of the up pressure (smaller) air bag on the last corn row. Trace both airlines back to the first corn row installing tees in each airline at each corn row. Route & install blue airline from the up pressure air bag fitting to the tee in the up pressure (blue) circuit for that corn row. Route & install black airline from the down pressure air bag fitting to the tee in the down pressure (black) circuit for that corn row. When back to the first corn row, cut each airline to length & install each airline into the matching air bag.

**Step 2: S1** At the dump valve on split row 3, cut & install a tee into the T1 airline installed in step 1. Route black airline from the remaining open port in the tee to the outlet port of the dump valve & install. Route & install black airline from the RD port on the 2940-101 compressor housing to the inlet port of the dump valve on split row 3.

**Step 3: S2** At the dump valve on corn row 4, cut & install a tee into the T2 airline installed in step 1. Route blue airline from the remaining open port in the tee to the outlet port of the dump valve & install. Route & install blue airline from the RU port on the 2940-101 compressor housing to the inlet port of the dump valve on corn row 4.

**Step 4: T3 & T4** Route black & blue airline from the first split row to the last split row. Install the black airline in the fitting of the down pressure (larger) air bag & the blue airline in the fitting of the up pressure (smaller) air bag on the last split row. Trace both airlines back to the first split row installing tees in each airline at each split row. Route & install blue airline from the up pressure air bag fitting to the tee in the up pressure (blue) circuit for that split row. Route & install black airline from the down pressure air bag fitting to the tee in the down pressure (black) circuit for that split row. When back to the first split row, cut each airline to length & install each airline into the matching air bag.

**Step 5:** At the dump valve on split row 3, cut & install a tee into the T3 airline installed in step 4. At the dump valve on corn row 4, cut & install a tee into the T4 airline installed in step 4.

**Step 6:** Install a tee just downstream of the outlet port on the dump valve on split row 3. Install a 6 inch piece of black airline in the remaining port of that tee. Install a ball valve (2940-342) on the open end of the 6 inch piece of black airline. Route & install black airline from the open port on the ball valve to the tee in the T3 airline installed in step 5.

**Step 7:** Install a tee just downstream of the outlet port on the dump valve on corn row 4. Install a 6 inch piece of blue airline in the remaining port of that tee. Install a ball valve on the open end of the 6 inch piece of blue airline. Route & install blue airline from the open port on the ball valve to the tee in the T4 airline installed in step 5.

**Step 8:** Install a plug in the WT port on the 2940-101 compressor housing. If plug not provided, install a 6 inch piece of any color of airline in the WT port, fold the airline in half causing a kink, & zip tie to keep airline in this position.

Up Pressure  
Blue Airline  
on corn rows

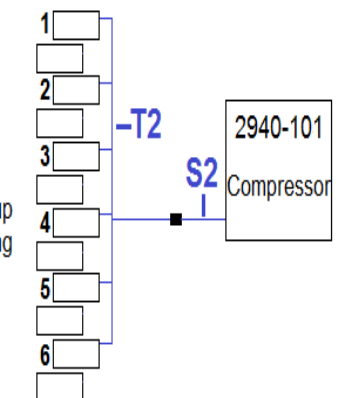

Up Pressure  
Blue Airline  
on split rows

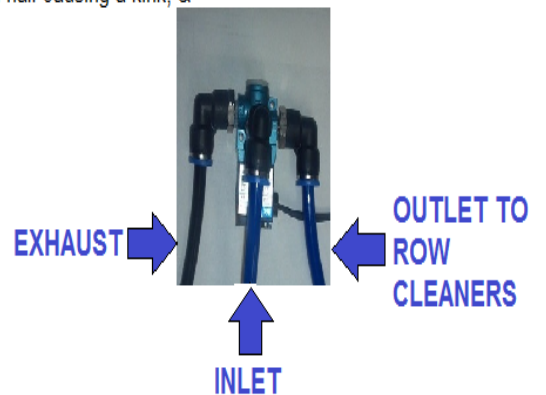
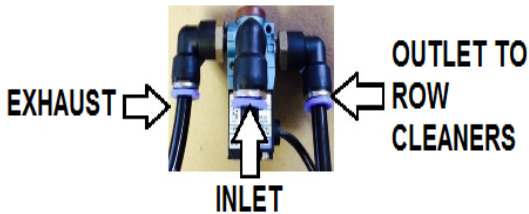
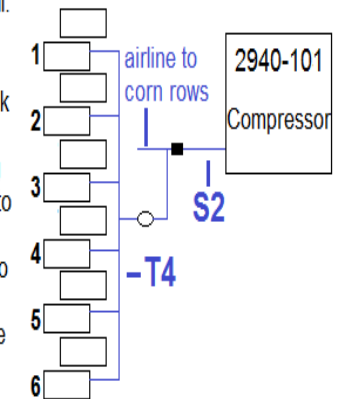

# 8 Row Dump Valve Diagram

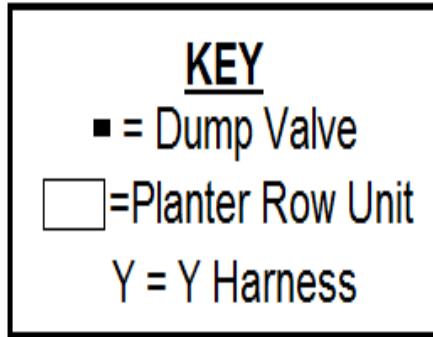

**Down  
Pressure  
Dump Valve**

**Up  
Pressure  
Dump Valve**

**Row**

**Row**

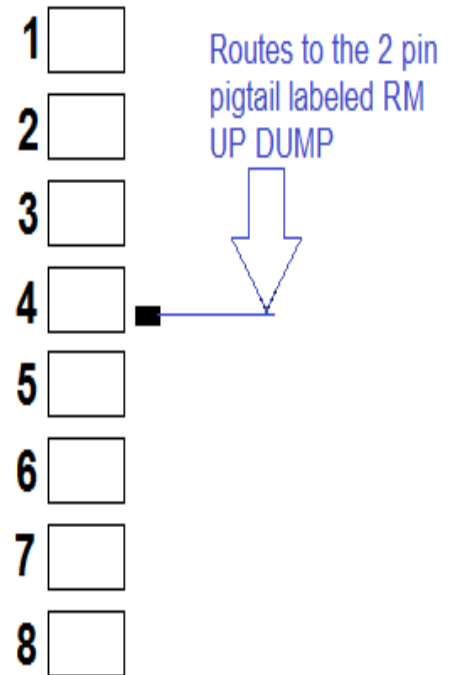
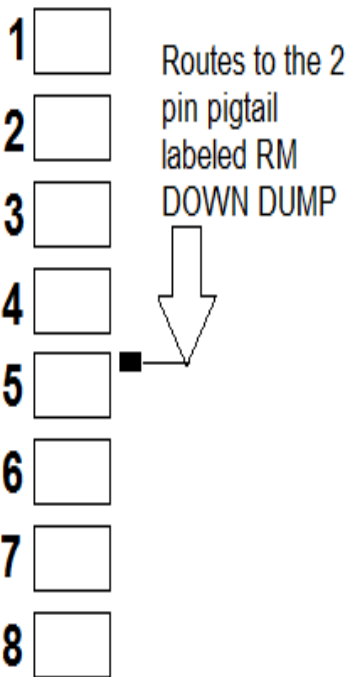

**Step 1:** Install 1 dump valve on row 4 & 1 dump valve on row 5.

**Step 2:** Install the male 12 pin Deutsch connector of the 2940-162 dump valve cable into the **GRAY** female connector on the underside of the 2940-101 compressor housing.

**Step 3:** Install the mating 2 pin connector of the 2940-156 black dump valve cable to the dump valve on row 5. Route the other end of the 2940-156 to the 2 pin connector labeled RM DOWN DUMP on the 2940-162 from step 2 & install.

**Step 4:** Install the mating 2 pin connector of the 2940-157 white dump valve cable to the dump valve on row 4. Route the other end of the 2940-157 to the 2 pin connector labeled RM UP DUMP on the 2940-162 from step 2 & install.

**★ Aux 3 & Aux 4 on 2940-162 are not yet used ★**

# 8 Row Airline Diagram

**Down Pressure  
Black Airline  
Row**

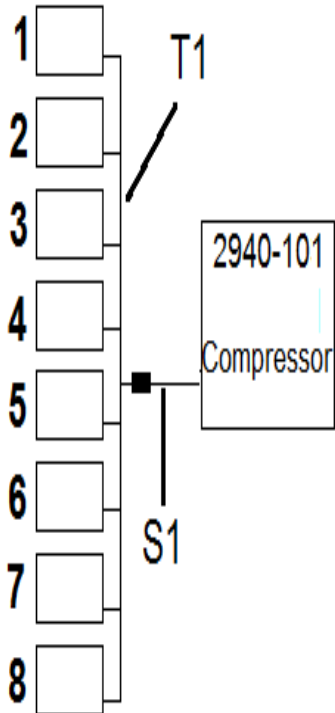

**Step 1: T1 & T2** Route blue & black airline from row 1 to row 8. Install the black airline in the down pressure (larger) air bag & blue airline in the up pressure (smaller) air bag. Trace both airlines back to row 1 installing tees in each (blue and black) airline at each row unit. From each tee in the up pressure (blue airline) circuit, route blue airline to the up pressure air bag and install in the fitting. From each tee in the down pressure (black airline) circuit, route black airline to the down pressure air bag and install in the fitting. When back to row 1, cut each airline to length and install each airline into the fitting of the matching air bag.

**Step 2:** On row 5 at the down pressure dump valve, install a tee in the black airline installed in step 1. Install black airline from the open port on the tee to the outlet port on the dump valve.

**Step 3:** On row 4 at the up pressure dump valve, install a tee in the blue airline installed in step 1. Install blue airline from the open port on the tee to the outlet port on the dump valve.

**Step 4: S1** Route & install black airline from the RD port in the 2940-101 compressor housing to the inlet port on the down pressure dump valve on row 5 & install.

**Step 5: S2** Route & install blue airline from the RU port on the 2940-101 compressor housing to the inlet port on the up pressure dump valve on row 4 & install.

**Step 6:** Install a plug (2940-352) into the WT port on the 2940-101 compressor housing to prevent air loss. Another way to do this is to cut a 6inch piece of black airline, install one end into the WT port, fold the airline over causing a kink, & zip tie the airline to stay like this. This circuit will not be used with this size of planter.

**Up Pressure  
Blue Airline  
Row**

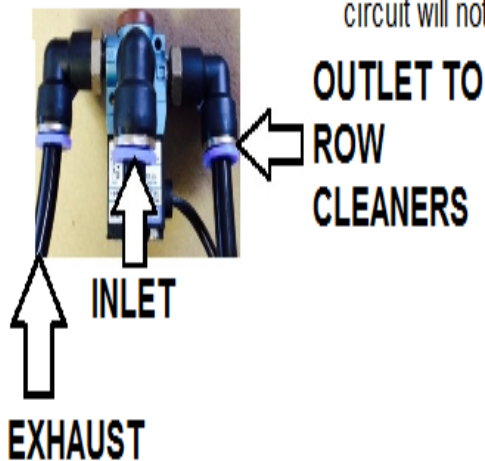
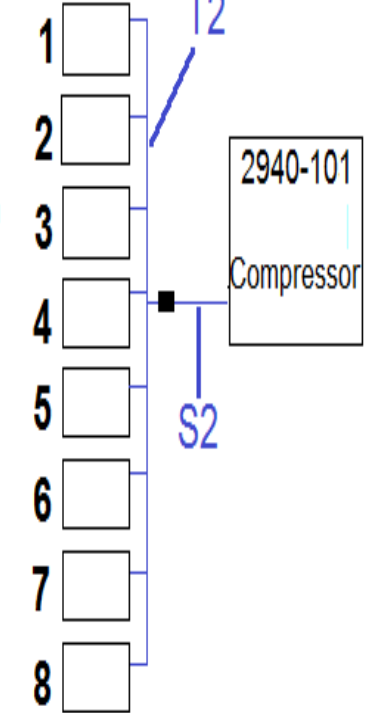

**KEY**

- = Dump Valve
- = Planter Row Unit
- T1-2 = Trunk Line
- S1-2 = Supply Line





# 8/15 or 8/16 Split Row Dump Valve Diagram

**KEY**

■ = Dump Valve

□ = Planter Row Unit

Y = Y Harness

**Down  
Pressure  
Dump Valve**

**Row**

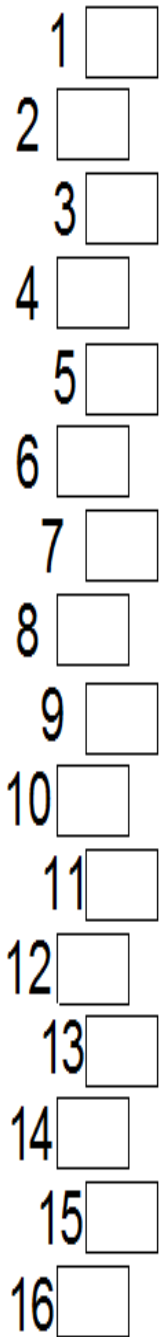

- Step 1:** Install 1 dump valve on each of the following rows: 5, 9, & 11.
- Step 2:** Install the male 12 pin Deutsch connector of the 2940-162 dump valve cable into the **GRAY** female connector on the side of the 2940-101 compressor housing.
- Step 3:** Install a 2940-156 15ft black dump valve cable on the 2 pin connector of the dump valve on row 5 and route to row 11 but don't install. Connect the black dump valve cable ran from the dump valve on row 5 and the 2 pin connector of the dump valve on row 11 using a 2940-158 black Y harness.
- Step 4:** Route & install the appropriate length of black dump valve cable(s) from the open 2 pin connector of the black Y harness at the dump valve on row 11 to the 2 pin connector labeled RM DOWN DUMP on the 2940-162 dump valve harness installed in step 2.
- Step 5:** Route & install the appropriate length of white dump valve cable(s) from the open 2 pin connector on the dump valve on row 9 to the 2 pin connector labeled RM UP DUMP on the 2940-162 dump valve harness installed in step 2.

**Up  
Pressure  
Dump Valve**

**Row**

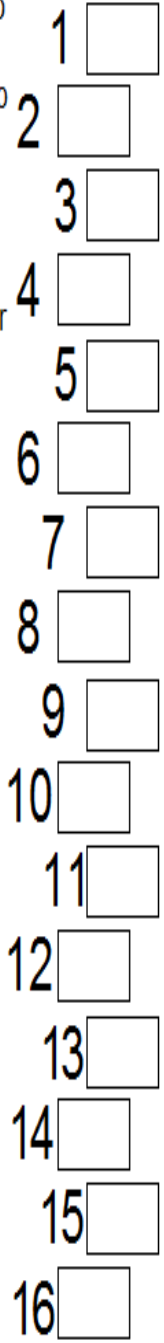

★ Aux 3 & Aux 4 on 2940-162 are not yet used ★

# 8/15 or 8/16 Split Row Airline Diagram

Down Pressure  
Black Airline  
on corn rows

Row

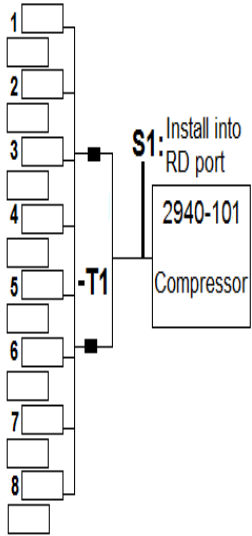

**KEY**

- = Dump Valve
- = Planter Row Unit
- = Ball Valve
- T1-4 = Trunk Line
- S1-2 = Supply Line

**Step 1: T1 & T2** Route black & blue airline from the first corn row to the last corn row. Install the black airline in the fitting of the down pressure (larger) air bag & the blue airline in the fitting of the up pressure (smaller) air bag on the last corn row. Trace both airlines back to the first corn row installing tees in each airline at each corn row. Route & install blue airline from the up pressure air bag fitting to the tee in the up pressure (blue) circuit for that corn row. Route & install black airline from the down pressure air bag fitting to the tee in the down pressure (black) circuit for that corn row. When back to the first corn row, cut each airline to length & install each airline into the matching air bag.

**Step 2: S1** At the dump valves on corn row 3 & corn row 6, cut & install a tee into the T1 airline installed in step 1. Route & install black airline from the remaining open port in each tee to the outlet port of the dump valve for that tee. Route & install black airline from the RD port on the 2940-101 compressor housing to the center of the planter & install a tee. From each side of the tee, route black airline to the inlet port of the dump valves on corn row 3 & corn row 6.

**Step 3: S2** At the dump valve on corn row 5, cut & install a tee into the T2 airline installed in step 1. Route blue airline from the remaining open port in the tee to the outlet port of the dump valve & install. Route & install blue airline from the RU port on the 2940-101 compressor housing to the inlet port of the dump valve on corn row 5.

**Step 4: T3 & T4** Route black & blue airline from the first split row to the last split row. Install the black airline in the fitting of the down pressure (larger) air bag & the blue airline in the fitting of the up pressure (smaller) air bag on the last split row. Trace both airlines back to the first split row installing tees in each airline at each split row. Route & install blue airline from the up pressure air bag fitting to the tee in the up pressure (blue) circuit for that split row. Route & install black airline from the down pressure air bag fitting to the tee in the down pressure (black) circuit for that split row. When back to the first split row, cut each airline to length & install each airline into the matching air bag.

**Step 5:** At the dump valves on corn row 3 & corn row 6, cut & install a tee into the T3 airline installed in step 4. At the dump valve on corn row 5, cut & install a tee into the T4 airline installed in step 4.

**Step 6:** Install a tee just downstream of the outlet port on the dump valves on corn row 3 & corn row 6. Install a 6 inch piece of black airline in the remaining port of that tee. Install a ball valve (2940-342) on the open end of each 6 inch piece black airline. Route & install black airline from the open port on each ball valve to each tee in the T3 airline installed in step 5.

**Step 7:** Install a tee just downstream of the outlet port on the dump valve on corn row 5. Install a 6 inch piece of blue airline in the remaining port of that tee. Install a ball valve on the open end of the 6 inch piece of blue airline. Route & install blue airline from the open port on the ball valve to the tee in the T4 airline installed in step 5.

**Step 8:** Install a plug in the WT port on the 2940-101 compressor housing. If plug not provided, install a 6 inch piece of any color of airline in the WT port, fold the airline in half causing a kink, & zip tie to keep airline in this position. The WT port is not used with this size of planter.

Up Pressure  
Blue Airline  
on corn rows

Row

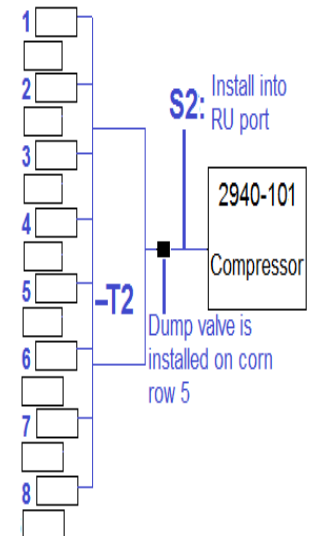

Down Pressure  
Black Airline  
on split rows

Row

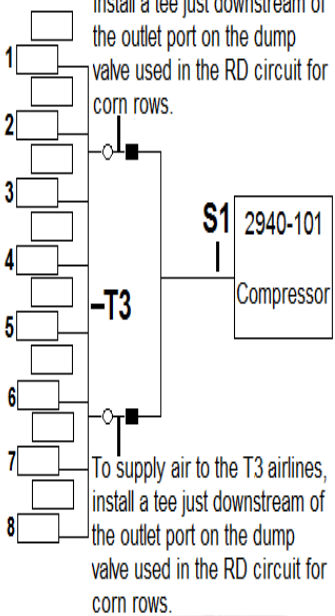

Up Pressure  
Blue Airline  
on split rows

Row

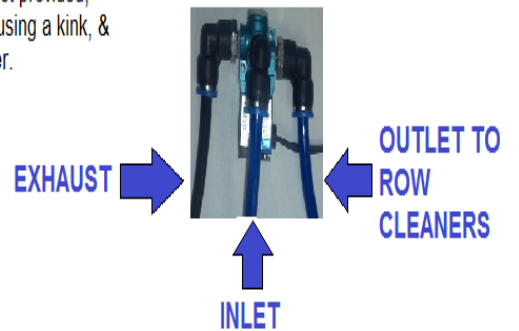
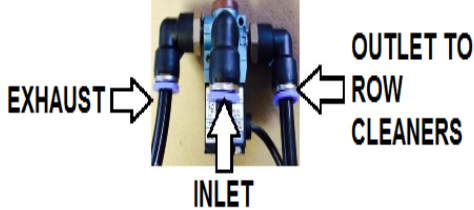
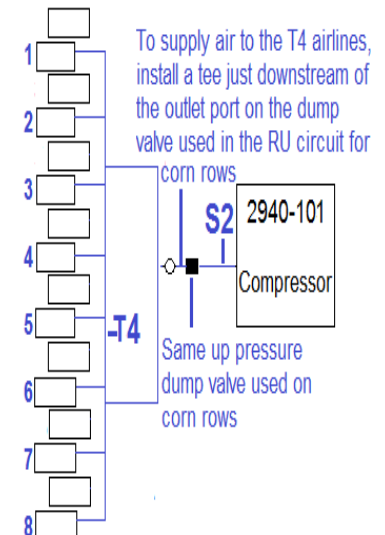

# 12 Row Dump Valve Diagram

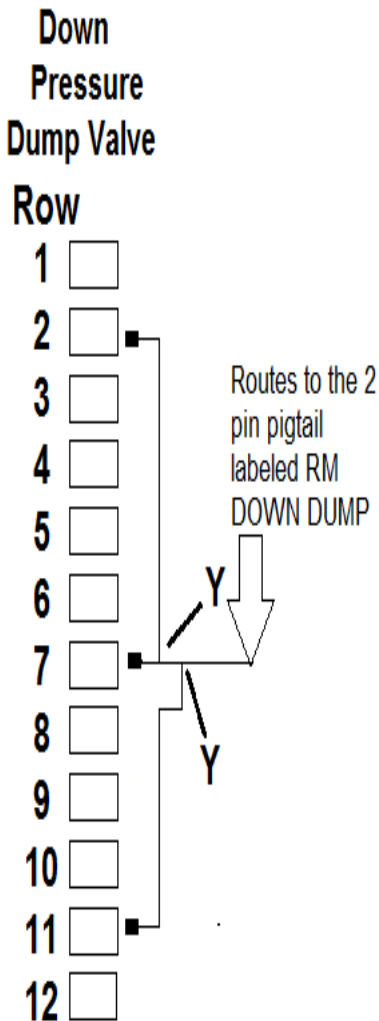
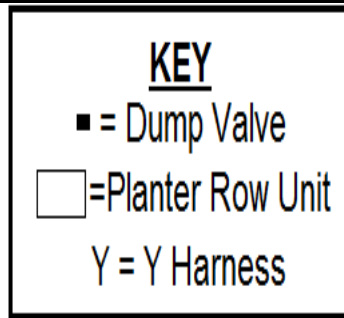

**Step 1:** Install 2 dump valves on each of the following rows: 2 & 11. Install 1 dump valve on each of the following rows: 6 & 7.

**Step 2:** Install the male 12 pin Deutsch connector of the 2940-162 dump valve cable into the **GRAY** female connector on the underside of the 2940-101 compressor housing.

**Step 3:** At row 2, install the mating 2 pin connector on the 2940-156 15ft black dump valve cable to the 2 pin cable on one dump valve and install the mating 2 pin connector on the 2940-157 15ft white dump valve cable to the 2 pin cable on the other dump valve. Route the 2940-156 black dump valve cable to row 7 but don't install. Route the 2940-157 white dump valve cable to the dump valve on row 6 but don't install.

**Step 4:** At row 11, install the mating 2 pin connector on the 2940-156 15ft black dump valve cable to the 2 pin cable on one dump valve and install the mating 2 pin connector on the 2940-157 15ft white dump valve cable to the 2 pin cable on the other dump valve. Route the 2940-156 black dump valve cable to row 7 but don't install. Route the 2940-157 white dump valve cable to the dump valve on row 6 but don't install.

**Step 5:** At row 7, install a 2940-158 black Y harness connecting the black dump valve cables routed in steps 3 & 4.

**Step 6:** Install a second black Y harness connecting the dump valve on row 7 to the Y harness installed in step 5.

**Step 7:** Route the appropriate length of black dump valve cable(s) from the open 2 pin connector at row 7 (from step 6) to the 2 pin connector labeled RM DOWN DUMP on the 2940-162 from step 2.

**Step 8:** At row 6, install a 2940-159 white Y harness connecting the white dump valve cables routed in steps 3 & 4.

**Step 9:** Install a second white Y harness connecting the dump valve on row 6 to the Y harness installed in step 8.

**Step 10:** Route appropriate length of white dump valve cable(s) from the open 2 pin connector at row 6 (from step 9) to the 2 pin connector labeled RM UP DUMP on the 2940-162 from step 2.

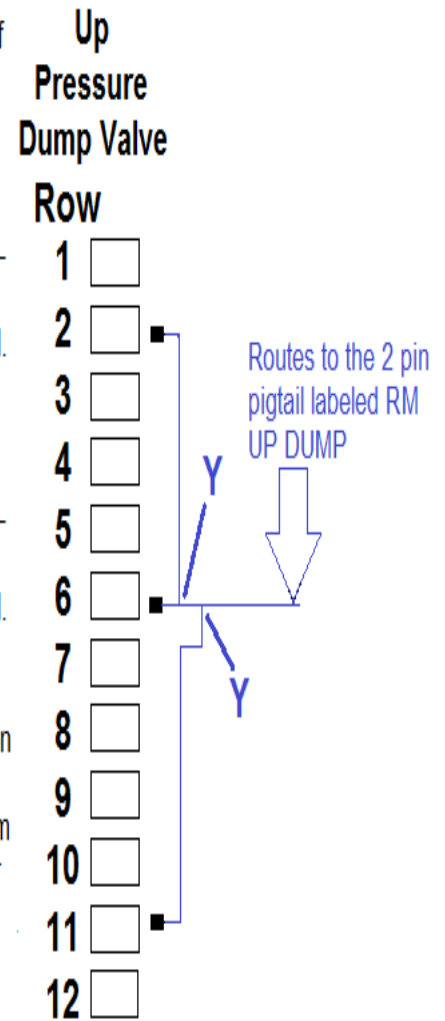

★ Aux 3 & Aux 4 on 2940-162 are not yet used ★

# 12 Row Airline Diagram

**Step 1: T1 & T2** Route blue & black airline from row 1 to row 3. Install the black airline in the down pressure (larger) air bag fitting & blue line in the up pressure (smaller) air bag fitting. Install a tee in each color of airline at row 2. Install blue airline from the up pressure air bag to the tee in the blue airline & black airline from the down pressure air bag to the tee in the black airline. At row 1, cut both airlines to length & install each airline into the matching air bag.

**Step 2:** Cut and tee T1 & T2 airline next to the matching dump valve on row 2. Route black airline from the tee in the T1 airline into the outlet port of the down pressure dump valve (black cable) and route blue airline from tee in the T2 airline to the outlet port of the up pressure dump valve (white cable).

**Step 3: T5 & T6** Route blue and black airline from row 12 to row 10. At row 10, install each airline into the matching air bag's fitting. Install a tee in each airline at row 11. Install blue airline from the up pressure air bag fitting to the tee in the blue airline & black airline from the down pressure air bag fitting to the tee in the black airline. At row 12, cut both airlines to length and install airline into the matching air bag.

**Step 4:** Cut and tee T5 & T6 airline next to the matching dump valve on row 11. Route black airline from the tee in the T5 airline into the outlet port of the down pressure dump valve (black cable) and route blue airline from tee in the T6 airline to the outlet port of the up pressure dump valve (white cable).

**Step 5: T3 & T4** Route blue and black airline from row 4 to row 9. Install each airline at row 9 into the matching air bag. Trace both airlines back to row 4 installing a tee in each airline at each row. Install blue airline from the up pressure air bag fitting to the tee in the up pressure circuit. Install black airline from the down pressure air bag fitting to the tee in the down pressure circuit. At row 4, cut both airlines to length and install into the matching air bag.

**Step 6:** Cut and tee T3 airline next to the dump valve on row 7. Install a tee in the T4 airline next to the dump valve on row 6. Route & install black airline from the tee in T3 airline into the outlet port of down pressure dump valve on row 7 and route blue airline from the tee in T4 to the outlet port of the up pressure dump valve on row 6.

**Step 7: S1** Route black airline from RD port of the 2940-101 compressor housing to the nearest point on the main frame and install a tee. From each side of the tee, route black airline to the inlet port on the down pressure dump valve on each wing/side of the planter. (Rows 2 and 11) (follow the same routing path as the trunk lines)

**Step 8: S2** Route blue airline from the RU port of the 2940-101 compressor housing to the nearest point on the main frame and install a tee. Install a 6 inch piece of blue line into one port of tee. Install a second tee on the open end 6 inch piece of blue airline. This will give you 3 open ports on this circuit to use. Route blue airline from 2 of those ports to each inlet port on the up pressure dump valve on the wings/sides of the planter on row 2 and row 11 & install. Route blue airline from remaining port of the tee to the inlet port on the up pressure dump valve on row 6 & install.

**Step 9: S3** Route black airline from the WT port of the 2940-101 compressor housing to the inlet port of the down pressure dump valve on row 7.

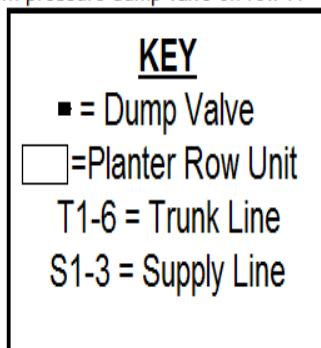
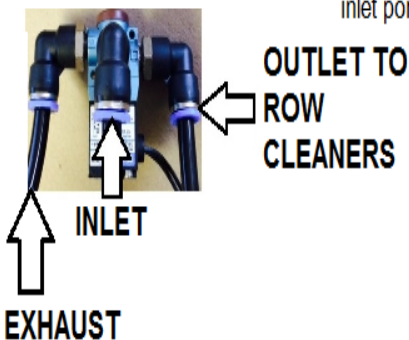
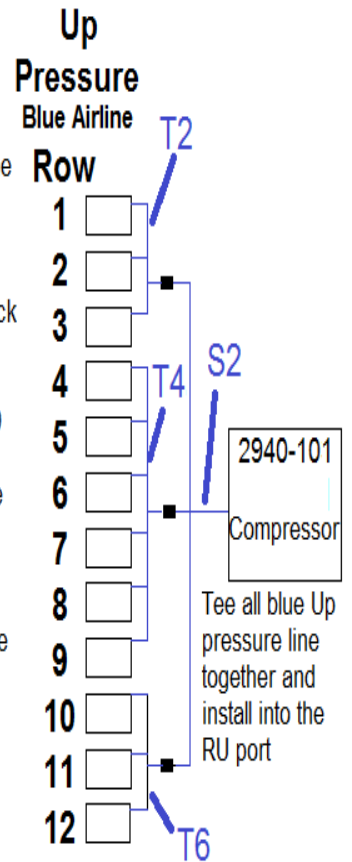
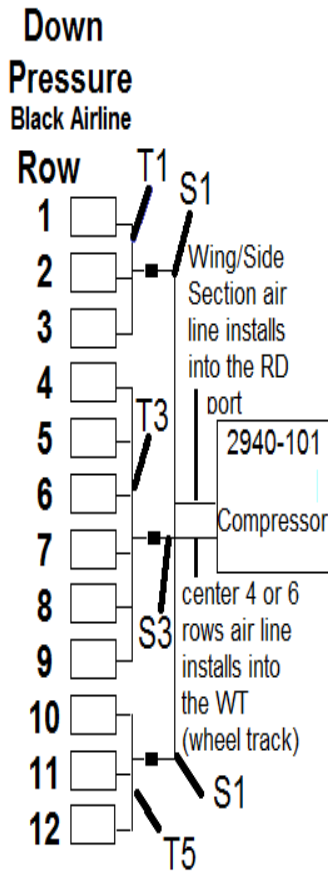

# 12/23 or 12/24 Split Row Dump Valve Diagram

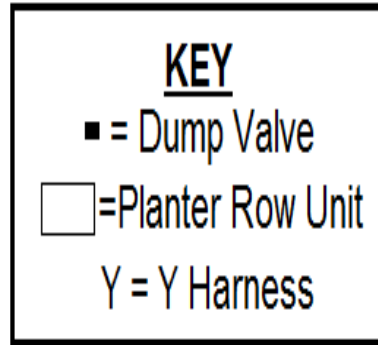

**Down  
Pressure  
Dump Valve  
Row**

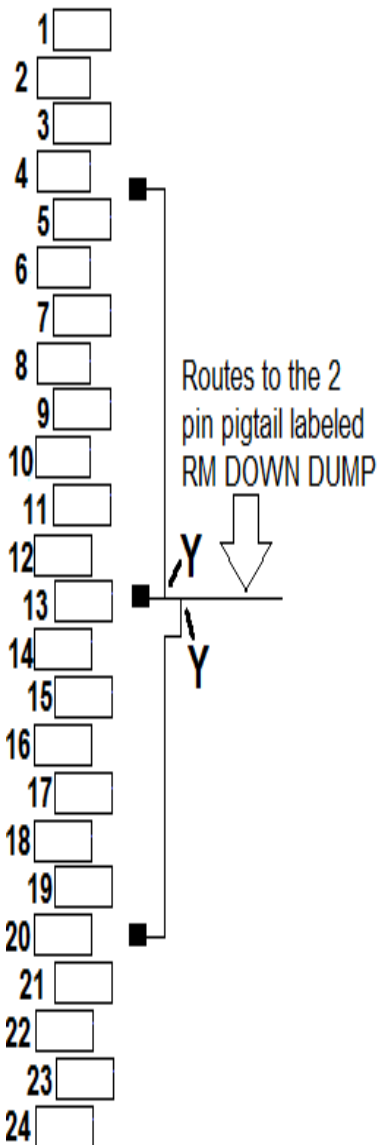

**Step 1:** Install 1 dump valve on each of the following rows: 4, 5, 12, 13, 19, & 20

**Step 2:** Install the male 12 pin Deutsch connector of the 2940-162 dump valve cable into the **GRAY** female connector on the underside of the 2940-101 compressor housing.

**Step 3:** At row 4 & 20, install a 2940-156 15ft black dump valve cable from the 2 pin connector on each dump valve and route to the dump valve on row 13 but don't install.

**Step 4:** At row 13, install a 2940-158 black Y harness to connect the 15ft black dump valve cables from row 4 & 20 (from step 3). Install a second black Y harness to connect the dump valve on row 13 to the Y harness connecting rows 4 & 20, so that only 1 open 2 pin connector remains.

**Step 5:** Route the appropriate length of black dump valve cable(s) from the open 2 pin connector on the Y harness from step 4 to the 2 pin connector labeled RM DOWN DUMP on the 2940-162 dump valve harness installed in step 2.

**Step 6:** At row 5 & 19, route 2940-157 15ft white dump valve cables from the 2 pin connector on each dump valve and route to the dump valve on row 12 but don't install

**Step 7:** At row 12, install a 2940-159 white Y harness connecting the cables routed from rows 5 & 19 in step 6. Install a second white Y harness to connect the dump valve on row 12 to the Y harness connecting rows 5 & 19.

**Step 8:** : Route the appropriate length of white dump valve cable(s) from the open 2 pin connector on the Y harness installed in step 7 to the 2 pin connector labeled RM UP DUMP on the 2940-162 dump valve harness installed in step 2.

**Up  
Pressure  
Dump Valve  
Row**

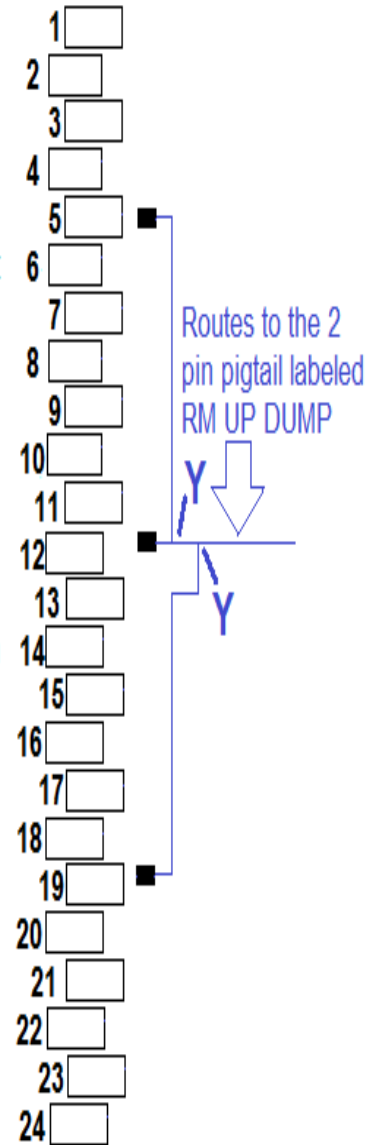

**★ Aux 3 & Aux 4 on 2940-162 are not yet used ★**

# 12/23 or 12/24 Split Row Airline Diagram

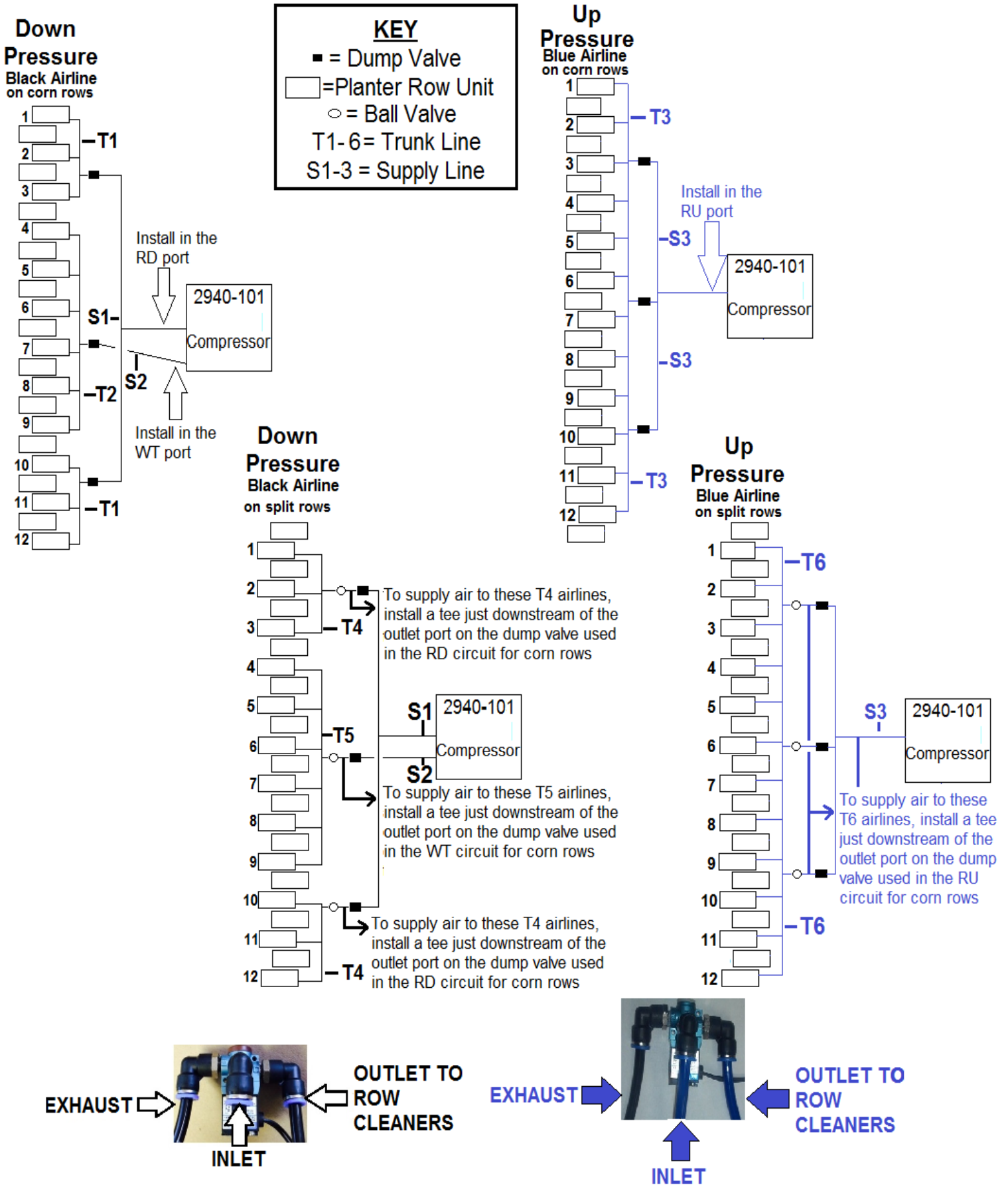

# 12/23 or 12/24 Split Row Airline Diagram Con't

**Step 1: T1** Route black airline from corn row 1 to corn row 3 & install the airline into the down pressure air bag (larger) fitting. Trace this same airline back to corn 1, installing a tee at corn row 2, & then cutting the black airline to length and installing in the down pressure air bag fitting on corn row 1. Install an additional black airline in the down pressure air bag fitting on corn row 2, cut to length, & install in the tee for that row.

**Step 2: T1** Route black airline from corn row 12 to corn row 10 & install into the down pressure air bag (larger) fitting. Trace this same airline back to corn row 12, installing a tee at corn row 11, & then cutting the black airline to length & installing in the down pressure air bag fitting on corn row 12. Install an additional black airline in the down pressure air bag fitting on corn row 11, cut to length, & install in the tee for that row.

**Step 3: S1** Install a tee in the black airline routing from corn row 1 to corn row 3. Install black airline in the remaining port of the tee & route to the outlet port of the dump valve on row 4 (split row 2) & install. Install a tee in the black airline that routes from corn row 10 to corn row 12. Install black airline in the remaining port of the tee, route to the outlet port of the dump valve on row 20 (split row 10), & install.

**Step 4: S1** Route & install black airline from the inlet port of the dump valves (used in step 3) on rows 4 & 20 to the center of the planter & install a tee to connect the airlines together. Install black airline in the open port of the tee, route to the RD port of the 2940-101 compressor housing, & install.

**Step 5: T2** Route black airline from corn row 4 to corn row 9 & install the black airline into the fitting of the down pressure air bag on corn row 9. Trace this airline back to corn row 4, installing a tee at each corn row. When returned to corn row 4, cut to length & install into the fitting of the down pressure air bag. Install black airline from the down pressure air bag fittings on corn rows 5-8, route to the tee installed for that row, & install.

**Step 6: S2** Install a tee into the black airline installed in the first part of step 5 (T2) near the dump valve on row 13 (corn row 7). Measure & cut black airline to length between the tee & the dump valve on row 13. Install the black airline into the tee & into the outlet port on the dump valve on row 13.

**Step 7: S2** Install black airline from the inlet port of the dump valve on row 13 (from step 6), route to the WT port on the 2940-101 compressor housing, & install.

**Step 8: T3** Route blue airline from corn row 1 to corn row 12 and install into the up pressure air bag (smaller) fitting on corn row 12. Trace this airline back to corn row 1, installing tees at each corn row. When returned to corn row 1, cut to length & install into the up pressure air bag fitting. Install blue airline into the up pressure air bag fitting on each corn row, cut to length, & install into the tee for that corn row.

**Step 9: S3** Install a tee into the T3 airline (from step 8) next to the dump valves on rows 5, 12, & 19. Measure & cut blue airline to length between the tee & the dump valves. Install the blue airline from the tee to the outlet port of each dump valve.

**Step 10: S3** Install blue airline from the inlet port on the dump valves on rows 5 & 19 & route to the dump valve on row 12. Install a tee connecting the blue airline routed from the dump valves on rows 5 & 19. Measure, cut, & install blue airline from the remaining open port of the tee to the inlet port of the dump valve on row 12. Install an additional tee in the blue airline between the dump valve on row 19 and tee that connects row 19 & row 5's dump valves. Route blue airline from the remaining port of the tee to the RU port of the 2940-101 compressor housing & install.

**Step 11: T4** Route black airline from split row 1 to split row 3 & install into the down pressure air bag (larger) fitting. Trace this same airline back to split row 1, installing a tee at split row 2, & then cutting the black airline to length & installing in the down pressure air bag fitting on split row 1. Install an additional black airline in the down pressure air bag fitting on split row 2, cut to length, & install in the tee for that row.

**Step 12: T4** Route black airline from split row 11/12 to split row 10 & install into the down pressure air bag (larger) fitting. Trace this same airline back to split row 12, installing a tee at split row 11, cut the black airline to length & install in the down pressure air bag fitting on split row 12. Install an additional black airline in the down pressure air bag fitting on corn row 11 & cut to length to install in the tee for that row. If equipped with only 11 split rows, route black airline from split row 11 to split row 10 & install in the down pressure air bag fitting. Cut the black airline to length & install in the down pressure air bag fitting on row 11.

**Step 13: S1** Install a tee just downstream of the outlet port on the dump valve on split row 2. Install a 6 inch piece of black airline in the tee. Install a 2940-342 ball valve on the open end of the 6 inch piece of black airline. Install a tee in the T4 airline installed in step 11 next to the dump valve on split row 2. Route & install black airline from the remaining open port of the tee in the T4 airline to the open port of the ball valve. Install a tee in the T4 airline installed in step 12 next to the dump valve on split row 10.

**Step 14: S4** Install a tee just downstream of the outlet port on the dump valve on split row 10. Install a 6 inch piece of black airline in the tee. Install a 2940-342 ball valve on the open end of the 6 inch piece of black airline. Install a tee in the T4 airline installed in step 12 next to the dump valve on split row 10. Route & install black airline from the remaining open port of the tee in the T4 airline to the open port of the ball valve.

**Step 15: T5** Route black airline from split row 4 to split row 9 & install into the down pressure air bag fitting on split row 9. Trace this same airline back to split row 4 installing a tee at each split row. At split row 4, cut the black airline to length & install into the down pressure air bag fitting. Install black airline from the down pressure air bag fitting on split rows 5-8, cut to length, & install into the tee for that row.

**Step 16: S2** Install a tee just downstream of the outlet port on the dump valve on split row 10. Install a 6 inch piece of black airline in the tee. Install a 2940-342 ball valve on the open end of the 6 inch piece of black airline. Install a tee in the T5 airline installed in step 15 next to the dump valve on split row 10. Route & install black airline from the remaining open port of the tee in the T5 airline to the open port of the ball valve.

**Step 17: T6** Install blue airline from split row 1 to the last split row & install in the up pressure air bag fitting. Trace this line back to split row 1, installing a tee at each split row. When returned to split row 1, cut the airline to length & install in the up pressure air bag. Install an additional blue airline in the up pressure air bag fitting on split rows 2 -10/11, route to the tee for that row, & install.

**Step 18: S3** Install a tee just downstream of the up pressure dump valves on rows 5, 12, & 19. Install a 6 inch piece of blue airline in each tee. Install a 2940-342 ball valve on the open end of each 6 inch piece of blue airline. Install a tee in the T6 airline (from step 17) next to each dump valve on rows 5, 12, & 19. Route & install blue airline from the tee to the nearest ball valve to that tee.

# 16 Row Dump Valve Diagram

**KEY**

- = Dump Valve
- = Planter Row Unit
- Y = Y Harness

**Step 1:** Install 1 dump valve on each of the following rows: 3, 4, 8, 9, 13, & 14.

**Step 2:** Install the male 12 pin Deutsch connector of the 2940-162 dump valve cable into the **GRAY** female connector on the underside of the 2940-101 compressor housing.

**Step 3:** Install the mating 2 pin connector of the 2940-156 15ft black dump valve cable to the 2 pin cable on the dump valve on row 3 and route to the dump valve on row 9 but don't install.

**Step 4:** Install the mating 2 pin connector of the 2940-156 15ft black dump valve cable to the 2 pin cable on the dump valve on row 14 and route to the dump valve on row 9 but don't install.

**Step 5:** At row 9, install a 2940-158 black Y harness connecting the dump valve cables routed from the dump valves on row 3 & row 14 from steps 3 & 4.

**Step 6:** Install a second black Y harness connecting the dump valve on row 9 to the Y harness installed in step 5.

**Step 7:** Route the appropriate length of black dump valve cable(s) from the open 2 pin connector at row 9 (from step 6) to the 2 pin connector labeled RM DOWN DUMP on the 2940-162 installed in step 2.

**Step 8:** Install the mating 2 pin connector of the 2940-157 15ft white dump valve cable to the 2 pin cable on the dump valve on row 4 and route to the dump valve on row 8 but don't install.

**Step 9:** Install the mating 2 pin connector of the 2940-157 15ft white dump valve cable to the 2 pin cable on the dump valve on row 13 and route to the dump valve on row 8 but don't install.

**Step 10:** At row 8, install a 2940-159 white Y harness connecting the dump valve cables routed from the dump valves on row 4 & row 13 from steps 8 & 9.

**Step 11:** Install a second white Y harness connecting the dump valve on row 8 to the Y harness installed in step 10.

**Step 12:** Route the appropriate length of white dump valve cable(s) from the open 2 pin connector at row 8 (from step 11) to the 2 pin connector labeled RM UP DUMP on the 2940-162 installed in step 2.

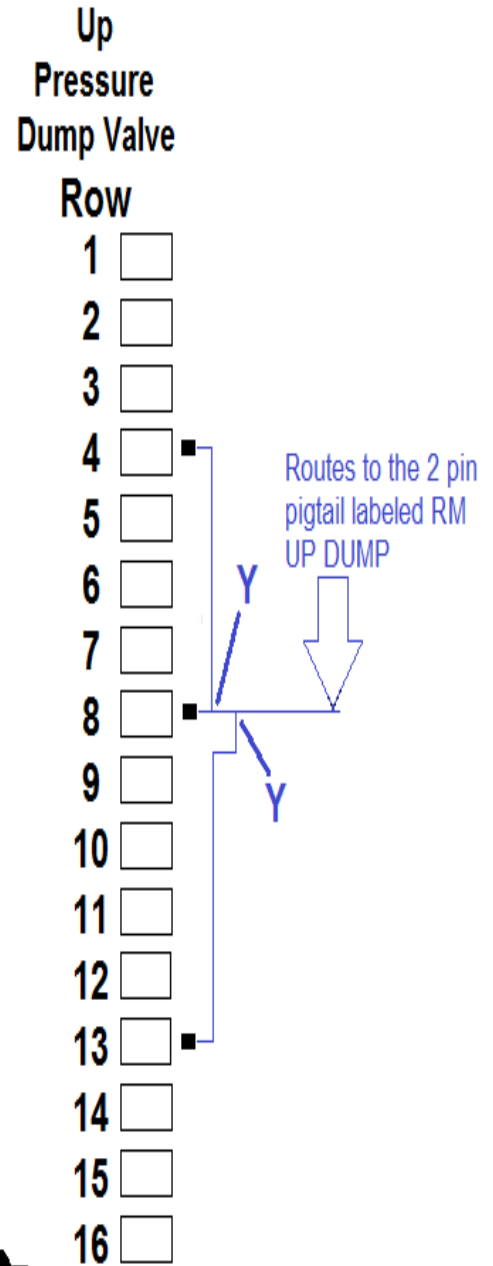
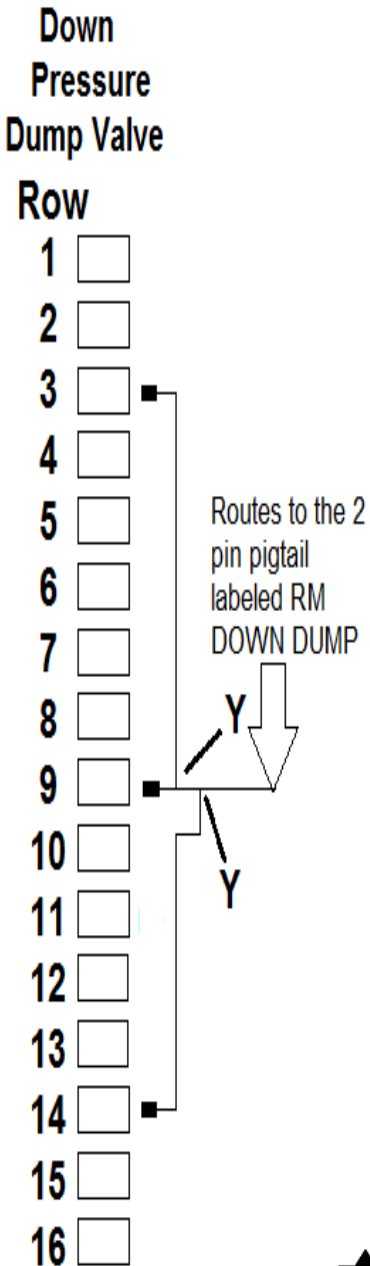

★ Aux 3 & Aux 4 on 2940-162 are not yet used ★



# 16 Row Airline Diagram

**Step 1: T1 & T2** Route blue & black airline from row 1 to row 5. At row 5, install the black airline in the down pressure (larger) air bag & blue airline in the up pressure (smaller) air bag. Trace both airline back to row 1 installing tees in each airline at each row unit. Route & install blue airline from the up pressure air bag fitting to the tee in the up pressure (blue) circuit for that row. Route & install black airline from the down pressure air bag fitting to the tee in the down pressure (black) circuit for that row. At row 1, cut both airlines to length & install each airline into the matching air bag.

**Step 2:** Install a tee in the T1 airline next to the dump valve on row 3. Route & install black airline from the tee in the T1 airline into the outlet port on the down pressure dump valve on row 3. Install a tee in the T2 airline next the up pressure dump valve on row 4. Route & install blue airline from tee in the T2 airline to the outlet port on the up pressure dump valve on row 4.

**Step 3: T5 & T6** Route blue & black airline from row 16 to row 12. At row 12, install the black airline in the down pressure (larger) air bag & blue airline in the up pressure (smaller) air bag. Trace both airlines back to row 16 installing tees in each airline at each row unit. Route & install blue airline from the up pressure air bag fitting to the tee in the up pressure (blue) circuit for that row. Route & install black airline from the down pressure air bag fitting to the tee in the down pressure (black) circuit for that row. At row 16, cut both airlines to length & install each airline into the matching air bag.

**Step 4:** Install a tee in the T5 airline next to the dump valve on row 14. Route & install black airline from the tee in the T5 airline into the outlet port of the down pressure dump valve on row 14. Install a tee in the T6 airline next to the dump valve on row 13. Install & route blue airline from tee in the T6 to the outlet port on the up pressure dump valve on row 13.

**Step 5: T3 & T4** Route blue & black airline from row 6 to row 11. At row 11, install the black airline in the down pressure (larger) air bag & blue airline in the up pressure (smaller) air bag. Trace both airlines back to row 6 installing tees in each airline at each row unit. Route & install blue airline from the up pressure air bag fitting to the tee in the up pressure (blue) circuit for that row. Route & install black airline from the down pressure air bag fitting to the tee in the down pressure (black) circuit for that row. At row 6, cut both airlines to length & install each airline into the matching air bag.

**Step 6:** Install a tee in the T3 airline next to the dump valve on row 9. Route & install black airline from the tee in the T3 airline into the outlet port of the down pressure dump valve on row 9. Install a tee in the T4 airline next to the dump valve on row 8. Install & route blue airline from tee in the T4 airline to the outlet port on the up pressure dump valve on row 8.

**Step 7: S1** Route black airline from RD port of the 2940-101 compressor housing to the nearest point on the main frame and install a tee. From each side of the tee, route & install black airline to the inlet port on the down pressure dump valves on rows 3 and 14. (follow the same routing path as the trunk lines)

**Step 8: S2** Route blue airline from the RU port of the 2940-101 compressor housing to the nearest point on the main frame and install a tee. Install a 6 inch piece of blue line into one of the remaining ports of the tee. Install a second tee on the open end of the 6 inch piece of blue airline. This will give you 3 open ports on this circuit to use. Route & install blue airline from 2 of those ports to each inlet port on the up pressure dump valves on rows 4 and 13. Route & install blue airline from remaining open port on the tee to the inlet port on the up pressure dump valve on row 8.

**Step 9: S3** Route & install black airline from the WT port of the 2940-101 compressor housing to the inlet port of the down pressure dump valve on row 9.

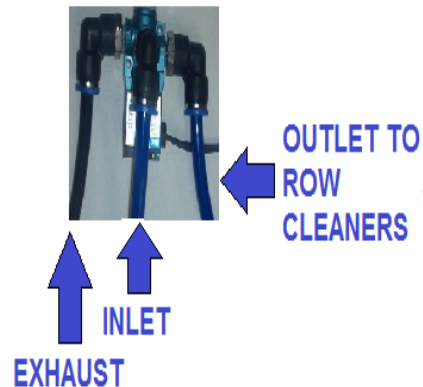
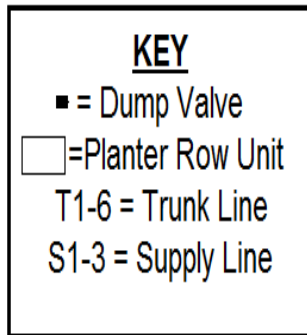
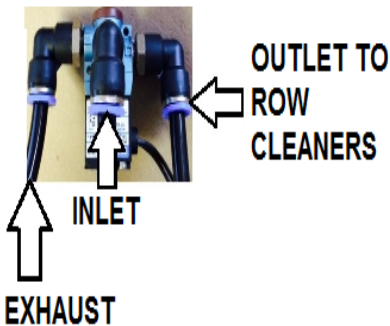
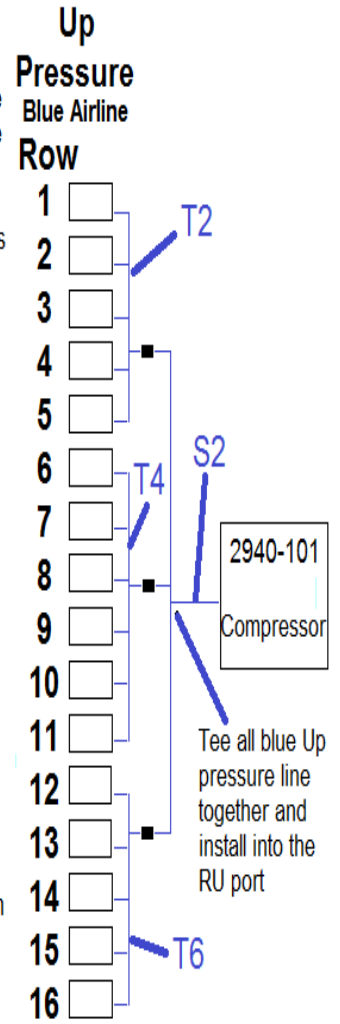
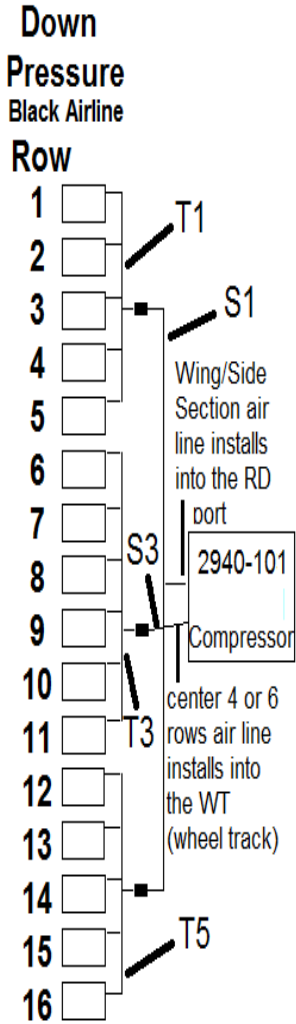

# 16/31 or 16/32 Split Row Dump Valve Diagram

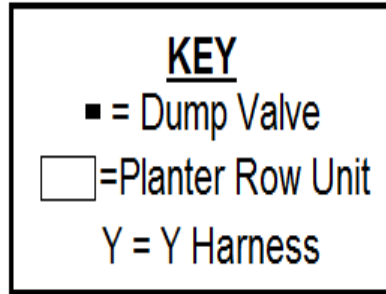

**Down  
Pressure  
Dump Valve**

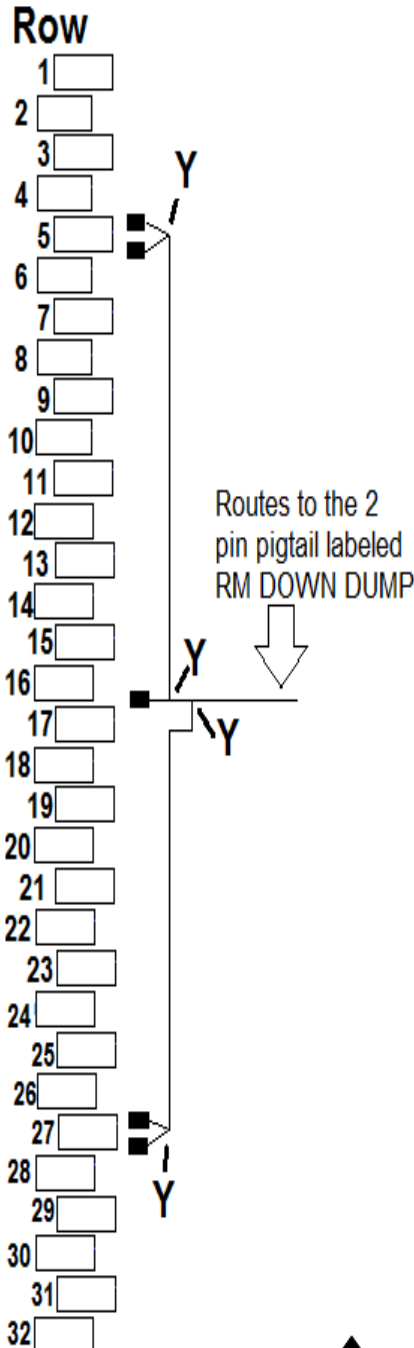

**Step 1:** Install 1 dump valve on each of the following rows: 6, 15, 16, & 26. Install 2 dump valves on each of the following rows: 5 & 27.

**Step 2:** Install the male 12 pin Deutsch connector of the 2940-162 dump valve cable into the **GRAY** female connector on the underside of the 2940-101 compressor housing.

**Step 3:** On rows 5 & 27, install a 2940-158 black Y harness to connect the dump valve's wiring harness leaving 1 open 2 pin connector on those rows.

**Step 4:** Install 2940-156 15ft black dump valve cable from the remaining open connector of the Y harnesses installed in step 3 on rows 5 & 27 and route to the dump valve on row 16 but don't install.

**Step 5:** Install a 2940-158 black Y harness connecting the 15ft black dump valve cables routed from rows 5 & 27 in step 4.

**Step 6:** Install another 2940-158 black Y harness connecting the Y harness from step 5 to the 2 pin connector on row 16, leaving one open 2 pin connector.

**Step 7:** Route the appropriate length of black dump valve cable(s) from the open 2 pin connector on the Y harness from step 6 to the 2 pin connector labeled RM DOWN DUMP on the 2940-162 dump valve harness installed in step 2.

**Step 8:** Route 2940-157 15ft white dump valve cables from dump valves on rows 6 and 26 to the dump valve on row 15 but don't install.

**Step 9:** Install a 2940-159 white Y harness connecting the white dump valve cables routed in step 8. Install a second white Y harness connecting row 15's dump valve to the white Y harness connecting rows 5 & 19, so that only 1 open 2 pin connector remains.

**Step 10:** Route the appropriate length of white dump valve cable(s) from the open 2 pin connector on the white Y harness installed in step 9 to the 2 pin connector labeled RM UP DUMP on the 2940-162 dump valve harness installed in step 2.

**Up  
Pressure  
Dump Valve**

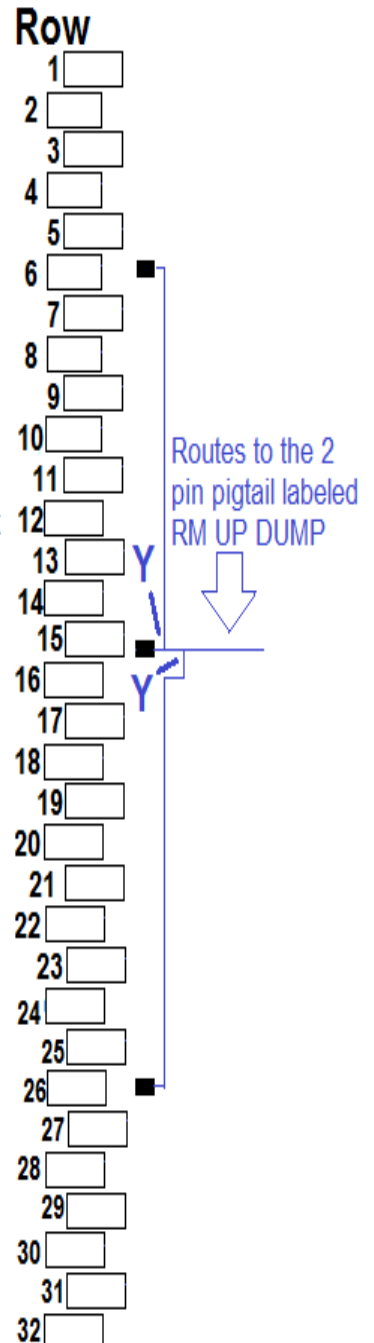

**★ Aux 3 & Aux 4 on 2940-162 are not yet used ★**

# 16/31 or 16/32 Row Airline Diagram

**Down Pressure**  
Black Airline  
on corn rows

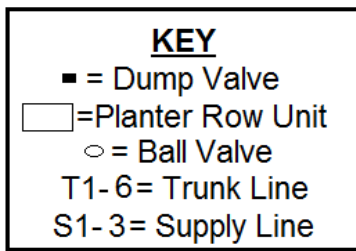
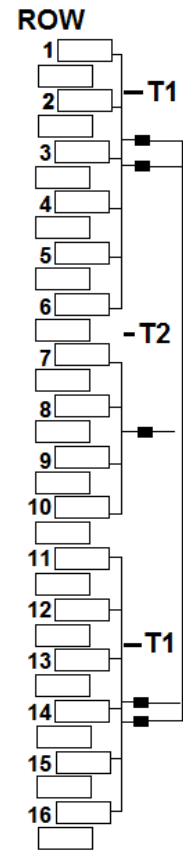

**Up Pressure**  
Blue Airline  
on corn rows

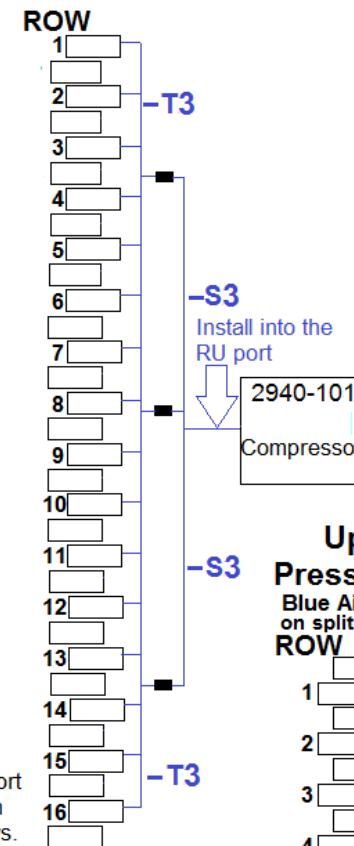

**Down Pressure**  
Black Airline  
on split rows

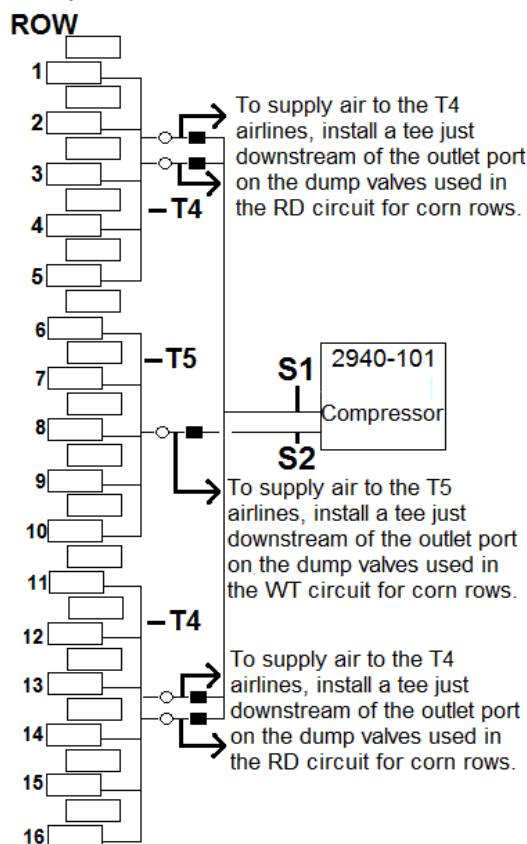

**Up Pressure**  
Blue Airline  
on split rows

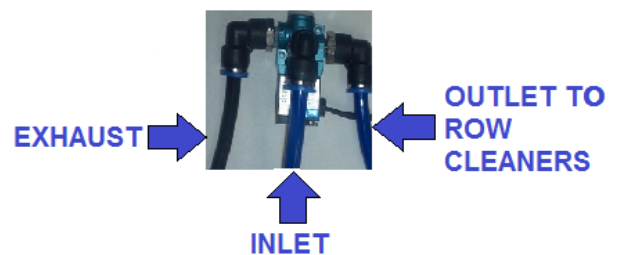
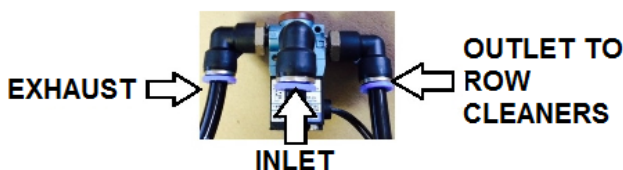
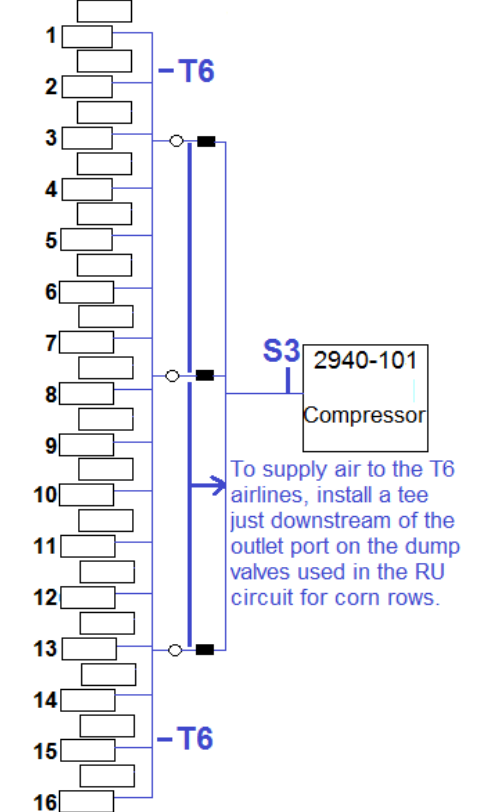

# 16/31 or 16/32 Row Airline Diagram Con't

- Step 1: T1** Route black airline from corn row 1 to corn row 6 & install the airline into the down pressure air bag (larger) fitting. Trace this same airline back to corn 1, installing a tee at each corn row. Cut the black airline to length and install the black airline in the down pressure air bag fitting on corn row 1. Install an additional black airline in the down pressure air bag fitting on corn rows 2-5, cut to length, & install in the tee for that row.
- Step 2: T1** Route black airline from corn row 16 to corn row 11 & install into the down pressure air bag (larger) fitting. Trace this same airline back to corn row 16, installing a tee each corn row. Cut the black airline to length & install the black airline in the down pressure air bag fitting on corn row 16. Install an additional black airline in the down pressure air bag fitting on each corn row, cut to length, & install in the tee for that row.
- Step 3: S1** Install a 2 tees (next to the dump valves on corn row 3) in the black airline routing from corn row 1 to corn row 6. Install black airline in the remaining port of each tee & route to the outlet ports of the dump valve on corn row 3 & install. Install 2 tees (next to the dump valves on corn row 14) in the black airline that routes from corn row 11 to corn row 16. Install black airline in the remaining port of each tee, route to the outlet port of each dump valve on row 20, & install.
- Step 4: S1** Route black airline from the RD port of the 2940-101 compressor housing to the nearest point on the frame of the planter & install a tee. From each side of the tee, route & install black airline to the inlet port of the furthest dump valve on corn row 3 & corn row 14. Install a tee in this airline next to the other dump valves on corn row 3 & corn row 14. Route & install black airline from the tee to the inlet port of the dump valve.
- Step 5: T2** Route black airline from corn row 7 to corn row 10 & install the black airline into the fitting of the down pressure air bag on corn row 10. Trace this airline back to corn row 7, installing a tee at each corn row. When returned to corn row 7, cut to length & install into the fitting of the down pressure air bag. Install black airline from the down pressure air bag fittings on corn rows 8 & 9, route to the tee installed for that row, & install.
- Step 6: S2** Install a tee into the black airline installed in the first part of step 5 (T2) near the dump valve on row 13 (corn row 7). Measure & cut black airline to length between the tee & the dump valve on row 13. Install the black airline into the tee & into the outlet port on the dump valve on row 13.
- Step 7: S2** Install black airline from the inlet port of the dump valve on row 13 (from step 6), route to the WT port on the 2940-101 compressor housing, & install.
- Step 8: T3** Route blue airline from corn row 1 to the last corn row and install into the up pressure air bag (smaller) fitting on the last corn row. Trace this airline back to corn row 1, installing tees at each corn row. When returned to corn row 1, cut to length & install into the up pressure air bag fitting. Install blue airline into the up pressure air bag fitting on each corn row, cut to length, & install into the tee for that row.
- Step 9: S3** Install a tee into the T3 airline (from step 8) next to the dump valves on rows 6, 15, & 26. Measure, cut, & install the blue airline to length between each tee & the dump valve for that tee.
- Step 10: S3** Install blue airline from the inlet port on the dump valves on rows 6 & 26, route to the dump valve on row 12, & install a tee connecting the blue airline routed from the dump valves on rows 6 & 26. Measure, cut, & install blue airline from the remaining open port of the tee to the inlet port of the dump valve on row 15. Install an additional tee in the blue airline between the dump valve on row 26 and tee that connects row 26 & row 6's dump valves. Route blue airline from the remaining port of the tee to the RU port of the 2940-101 compressor housing & install.
- Step 11: T4** Route black airline from split row 1 to split row 5 & install into the down pressure air bag (larger) fitting. Trace this same airline back to split row 1, installing a tee at split rows 2-4. When returned to split row 1, cut the black airline to length & install it in the down pressure air bag fitting. Install an additional black airline in the down pressure air bag fitting on split rows 2-4, cut to length, & install in the tee for that row.
- Step 12: T4** Route black airline from the last split row to split row 11 & install into the down pressure air bag (larger) fitting. Trace this same airline back to the last split row, installing a tee at split rows 12-14/15. When returned to the last split row, cut the black airline to length & install in the down pressure air bag fitting. Install an additional black airline in the down pressure air bag fitting on split rows 12-14/15, cut to length, & install in the tee for that row.
- Step 13: S1** Install a tee just downstream of the outlet port on each dump valve on corn row 3. Install a 6 inch piece of black airline in each tee. Install a 2940-342 ball valve on the open end of each 6 inch piece of black airline. Install tee in the T4 airline installed in step 11 next to each dump valves on corn row 3. Route & install black airline from the remaining open port of each tee in the T4 airline to the open port of each ball valve.
- Step 14: S1** Install a tee just downstream of the outlet port on each dump valve on corn row 14. Install a 6 inch piece of black airline in each tee. Install a 2940-342 ball valve on the open end of each 6 inch piece of black airline. Install a tee in the T4 airline installed in step 12 next to each dump valve on corn row 14. Route & install black airline from the remaining open port of each tee in the T4 airline to the open port of each ball valve.
- Step 15: T5** Route black airline from split row 6 to split row 10 & install into the down pressure air bag fitting on split row 10. Trace this same airline back to split row 6 installing a tee at each split row. At split row 6, cut the black airline to length & install into the down pressure air bag fitting. Install black airline from the down pressure air bag fitting on split rows 7-9, cut to length, & install into the tee for that row.
- Step 16: S2** Install a tee just downstream of the outlet port on the dump valve on split row 8. Install a 6 inch piece of black airline in the tee. Install a 2940-342 ball valve on the open end of the 6 inch piece of black airline. Install a tee in the T5 airline installed in step 15 next to the dump valve on split row 8. Route & install black airline from the remaining open port of the tee in the T5 airline to the open port of the ball valve.
- Step 17: T6** Install blue airline from split row 1 to the last split row & install in the up pressure air bag fitting. Trace this line back to split row 1, installing a tee at each split row. When returned to split row 1, cut the airline to length & install in the up pressure air bag. Install an additional blue airline in the up pressure air bag fitting on split rows 2 -14/15, route to the tee for that row, & install.
- Step 18: S3** Install a tee just downstream of the up pressure dump valves on rows 6, 15, & 26. Install a 6 inch piece of blue airline in each tee. Install a 2940-342 ball valve on the open end of each 6 inch piece of blue airline. Install a tee in the T6 airline (from step 17) next to each dump valve on rows 6, 15, & 26. Route & install blue airline from the tee to the nearest ball valve to that tee.

# 24 Row Dump Valve Diagram

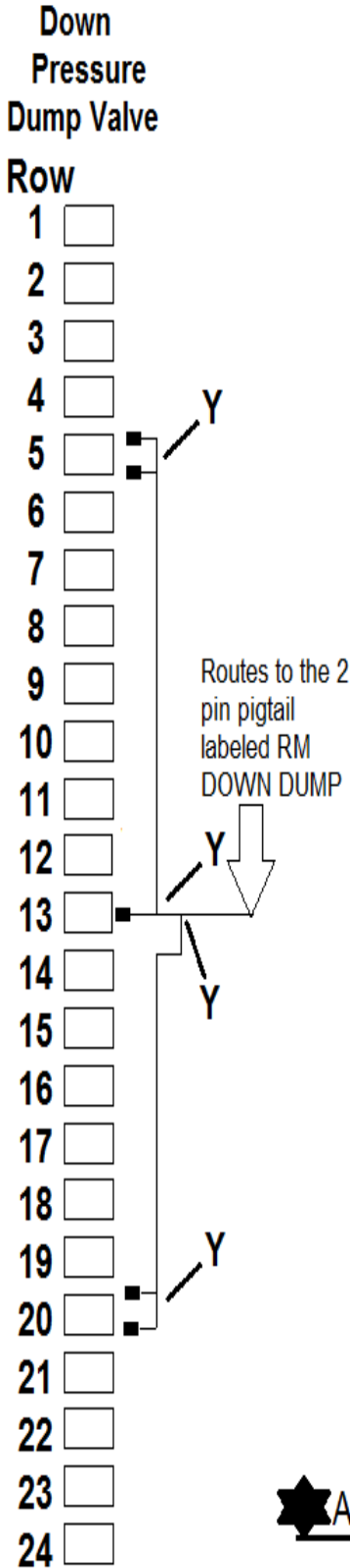
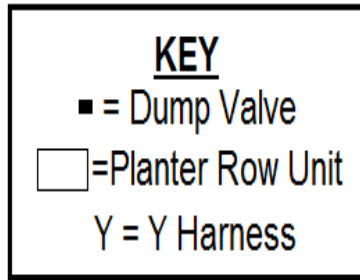

- Step 1:** Install 1 dump valve on each of the following rows: 6, 12, 13, & 19. Install 2 dump valves on each of the following rows: 5 & 20.
- Step 2:** Install the male 12 pin Deutsch connector of the 2940-162 dump valve cable into the **GRAY** female connector on the underside of the 2940-101 compressor housing.
- Step 3:** At row 5's dump valves, connect each dump valve's 2 pin cable using a 2940-161 black Y harness. Install a 2940-154 30ft black dump valve cable on the open end of the Y harness & route to row 13's dump valve but don't install.
- Step 4:** At row 20's dump valves, connect each dump valve's 2 pin cable using a 2940-161 black Y harness. Install a 2940-154 30ft black dump valve cable on the open end of the Y harness & route to row 13's dump valve but don't install.
- Step 5:** At row 13, use 1 black Y harness to connect the 30ft black dump valve cable routed from row 5 (step 3) and the 30ft black dump valve cable routed from row 20 (step 4). Use a second black Y harness to connect row 13's dump valve cable to the Y harness connecting row 5 and 20, leaving 1 open 2 pin connector.
- Step 6:** Route the appropriate length of black dump valve cable(s) from the open 2 pin connector at row 13 (from step 5) to the 2 pin connector labeled RM DOWN DUMP on the 2940-162 from step 2.
- Step 7:** At row 6's dump valve, connect the 2 pin connector of the dump valve to the mating 2 pin connector of the 2940-155 30ft white dump valve cable & route to the dump valve on row 12 but don't install. At row 19's dump valve, connect the 2 pin connector of the dump valve to the mating 2 pin connector of the 2940-155 30ft white dump valve cable and route to row 12 but don't install.
- Step 8:** At row 12, use a 2940-159 white Y harness to connect the white dump valve cables routed from the dump valve on row 6 & row 19 (in step 7) & install a second 2940-159 white Y harness to connect the dump valve on row 12 to the Y harness used to connect the dump valves on row 6 & 19 so that only 1) 2 pin connector remains.
- Step 9:** Route the appropriate length of white dump valve cable(s) from the open 2 pin connector of the Y harness at row 12 (from step 8) to the 2 pin connector labeled RM UP DUMP on the 2940-162 from step 2.

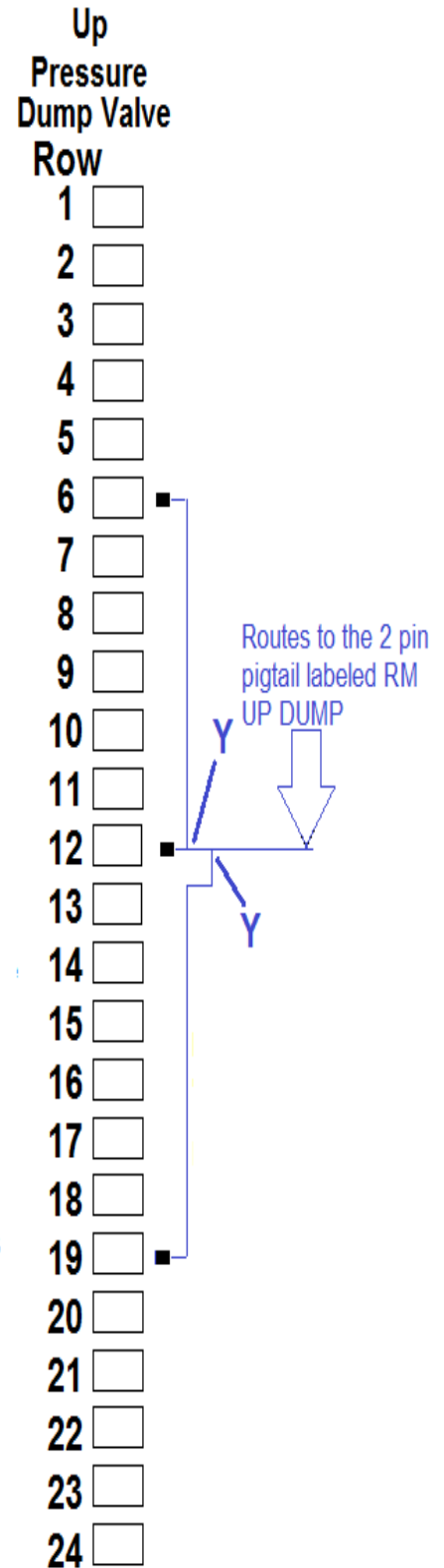

★ Aux 3 & Aux 4 on 2940-162 are not yet used ★

# 24 Row Airline Diagram

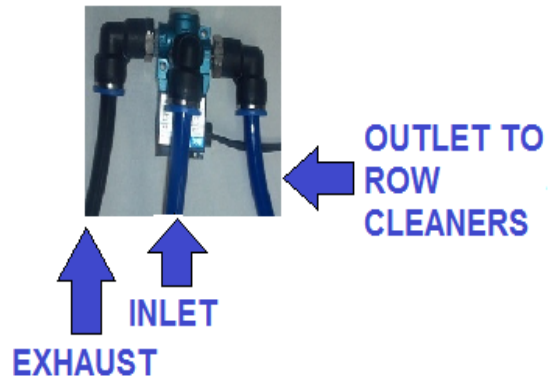
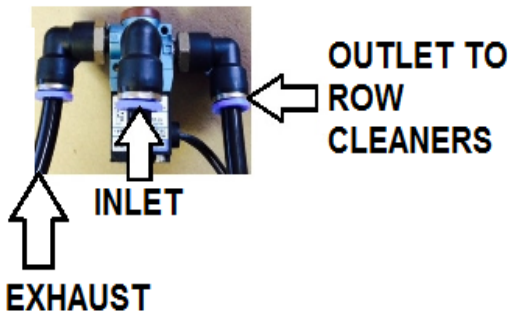
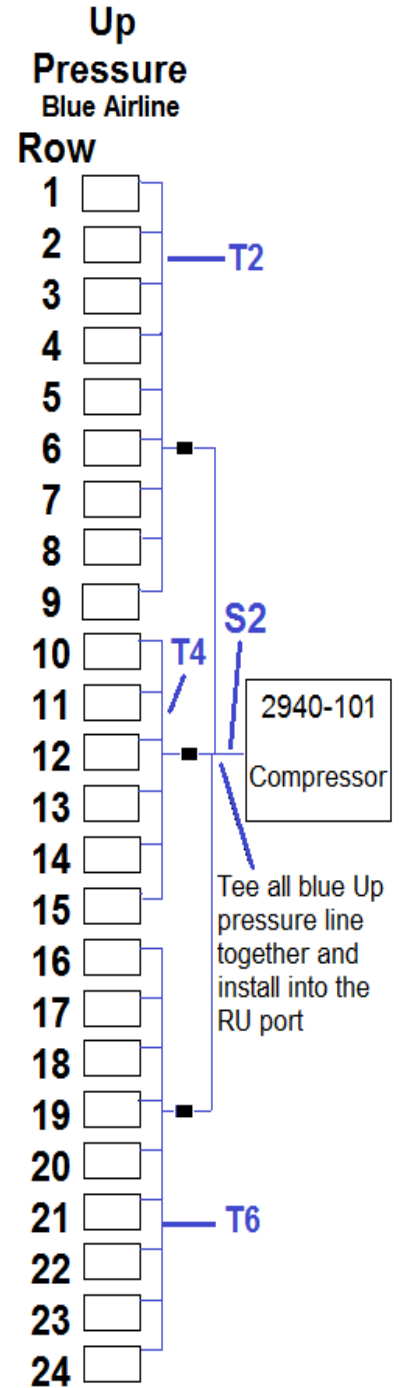
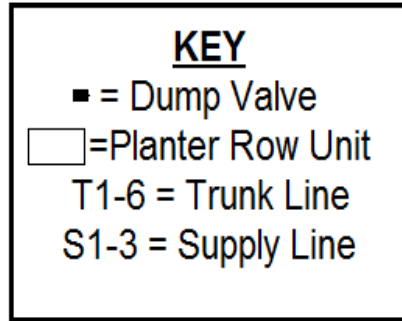
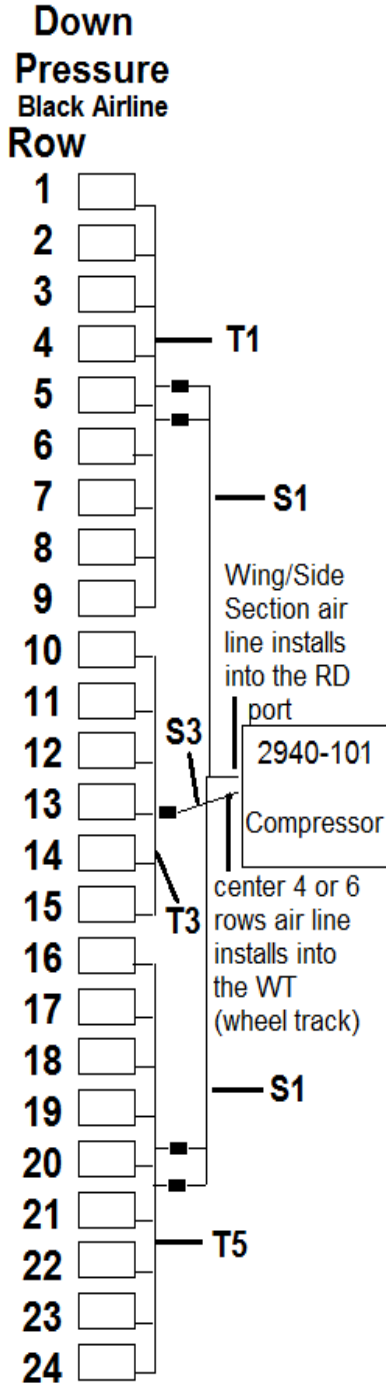

## 24 Row Airline Diagram Con't

**Step 1:T1 & T2** Route blue & black airline from row 1 to row 9. At row 9, install the black airline in the down pressure (larger) air bag & blue line in the up pressure (smaller) air bag. Trace both airline back to row 1 installing tees at each row unit in each airline. Install blue airline from the up pressure air bag fitting at each row to the tee in the up pressure (blue) circuit for that row. Install black airline from the down pressure air bag fitting at each row to the tee in the down pressure (black) circuit for that row. At row 1, cut both airlines to length & install each airline into the matching air bag.

**Step 2:** Install a tee in the T1 airline next to each down pressure dump valve on row 5. Install black airline from the outlet port on each down pressure dump valve on row 5 to the tee installed for that dump valve. Install a tee in the T2 airline next to the up pressure dump valve on row 6. Install blue airline from the outlet port on the up pressure dump valve on row 6 to the tee installed for that dump valve.

**Step 3:T5 & T6** Route blue & black airline from row 24 to row 16. Install each airline into the matching air bag on row 16. Trace both airlines back to row 24 installing tees at each row unit in each airline. Install blue airline from the up pressure air bags to the tee in the up pressure circuit for that row. Install black airline from the down pressure air bag to the tee in the down pressure circuit for that row. At row 24, cut both airlines to length and install each airline into the matching air bag.

**Step 4:** Install a tee in the T5 airline next to each down pressure dump valve on row 20. Install black airline from the outlet port on each down pressure dump valve on row 20 to the tee installed for that dump valve. Install a tee in the T6 airline next to the up pressure dump valve on row 19. Install blue airline from the outlet port of the up pressure dump valve on row 19 to the tee installed for that dump valve.

**Step 5:T3 & T4** Route blue and black airline from row 10 to row 15. Install each airline into the matching air bag on row 15. Trace both airlines back to row 10 installing tees at each row unit in each airline. Install blue airline from the up pressure air bags to the tee in the up pressure circuit for that row. Install black airline from the down pressure air bag to the tee in the down pressure circuit for that row. At row 10, cut both airlines to length and install each airline into the matching air bag.

**Step 6:** Install a tee in the T3 airline next to the dump valve on row 13. Install black airline from the outlet port on the down pressure dump valve on row 13 to the tee installed for that dump valve. Install a tee in the T4 airline next to the up pressure dump valve on row 12. Install blue airline from the outlet port of the up pressure dump valve on row 12 to the tee installed for that dump valve.

**Step 7:S1** Route black airline from RD port of the 2940-101 compressor housing to the nearest point on the main frame and install a tee. From each side of the tee, route black airline to the inlet port on the furthest down pressure dump valve on rows 5 and 20 (follow the same routing path as the trunk lines). Install a tee into the S1 airline next to the other down pressure dump valve on rows 5 and 20, route black airline from tee to the inlet port of each dump valve, & install.

**Step 8:S2** Route blue airline from the RU port of the 2940-101 compressor housing to the nearest point on the main frame and install a tee. Install a 6 inch piece of blue airline into one port of the tee. Install a second tee on the open end of the 6 inch piece of blue airline. This will give you 3 open ports on this circuit to use. Route & install blue airline from 2 of those ports to each inlet port on the up pressure dump valve on rows 6 and 19. Route & install blue airline from the remaining open port on the tee to the inlet on the up pressure dump valve on row 12.

**Step 9:S3** Route & install black airline from the WT port of the 2940-101 compressor housing to the inlet of the down pressure dump valve on row 13.

# 32 Row Dump Valve Diagram

**Down Pressure**  
Black Airline

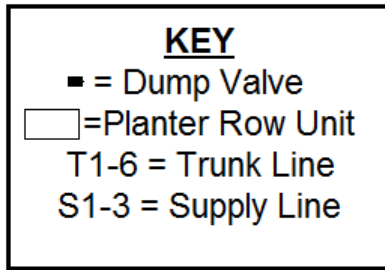
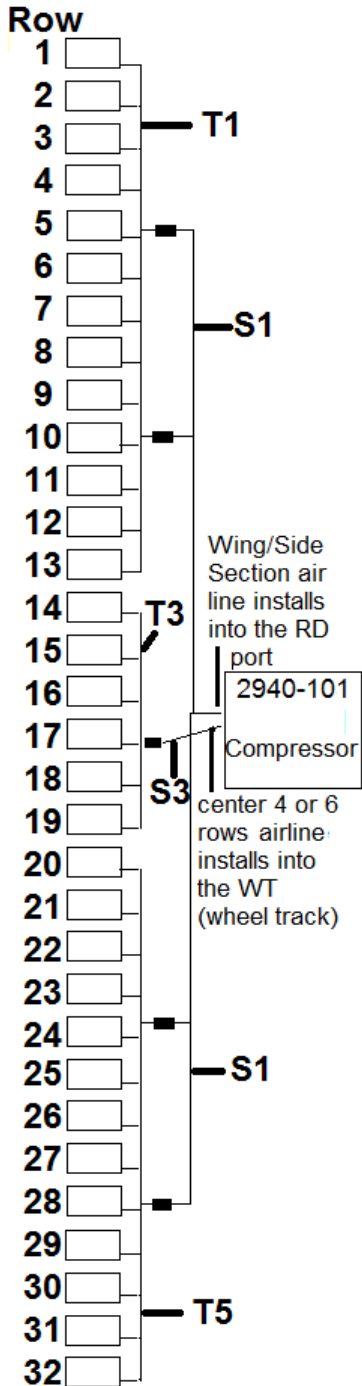

**Up Pressure**  
Blue Airline

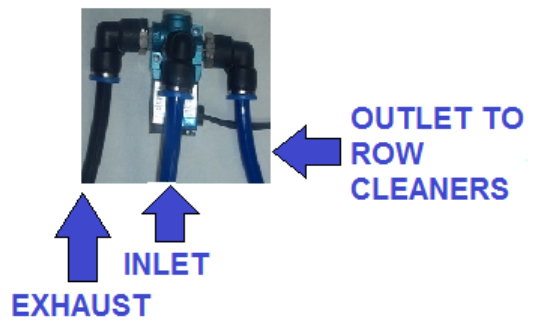
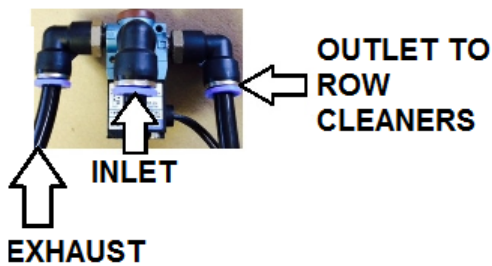
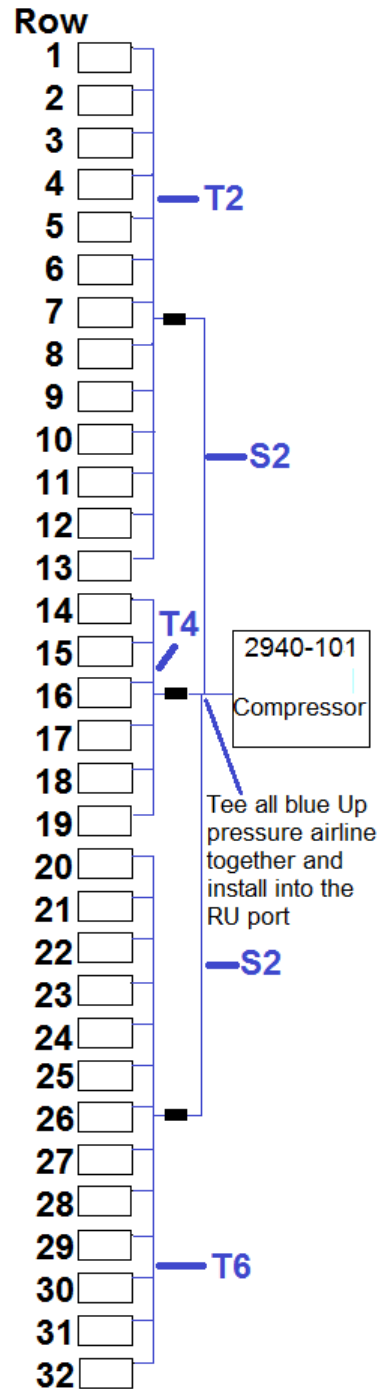



# 32 Row Airline Diagram

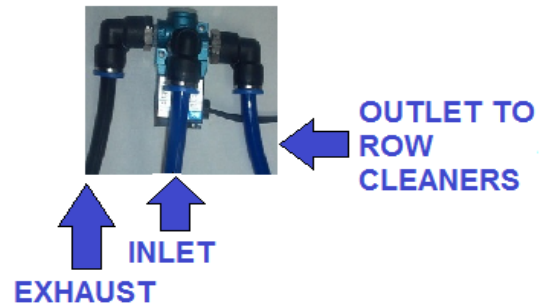
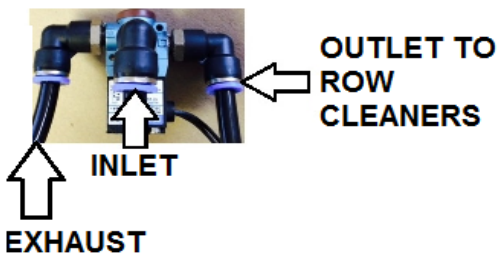
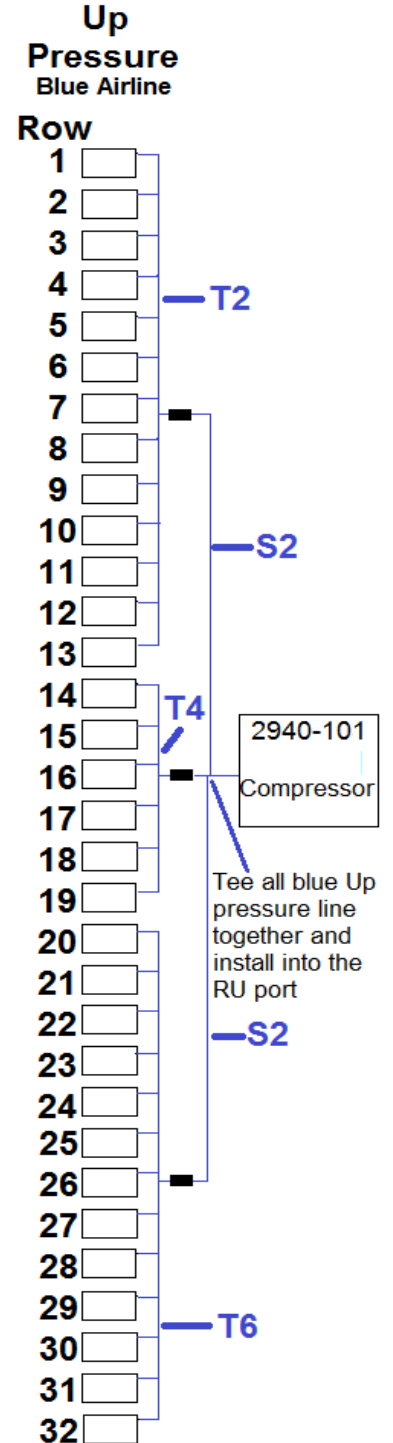
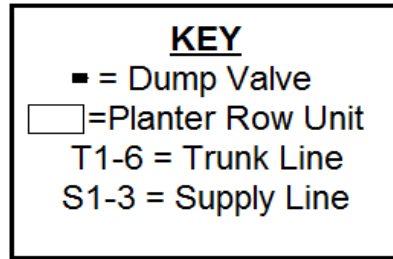
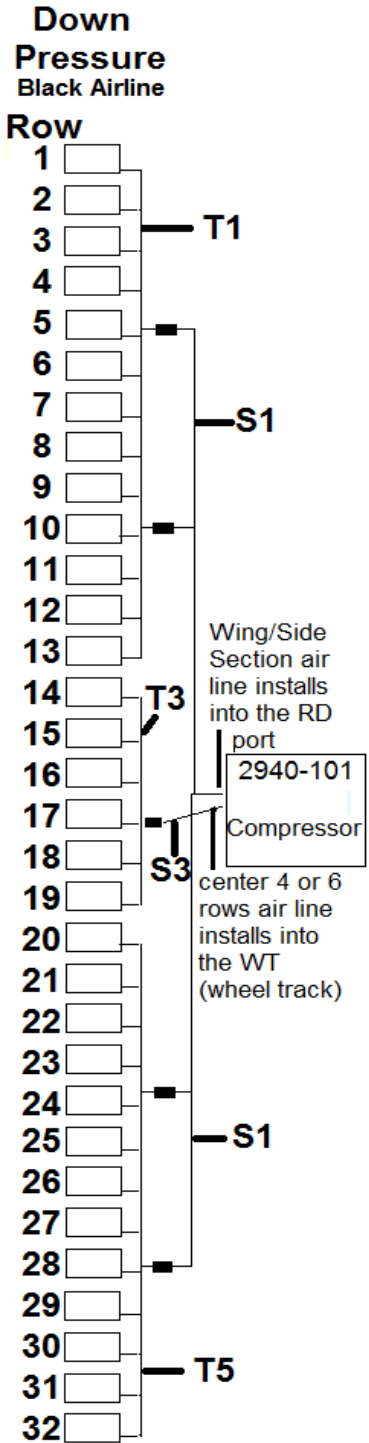

## 32 Row Airline Diagram Con't

**Step 1:T1 & T2** Route blue & black airline from row 1 to row 13. At row 13, install the black airline in the down pressure (larger) air bag & blue airline in the up pressure (smaller) air bag. Trace both airline back to row 1 installing tees in each airline at each row unit. Install blue airline from the up pressure air bag at each row to the tee in the up pressure (blue) circuit for that row. Install black airline from the down pressure air bag at each row to the tee in the down pressure (black) circuit for that row. At row 1, cut both airlines to length & install each airline into the matching air bag.

**Step 2:** Install a tee in the T1 airline next to each down pressure dump valve on row 5 and row 10. Install black airline from the outlet port on the down pressure dump valves on row 5 and row 10 to the tee installed for that dump valve. Install a tee in the T2 airline next to the up pressure dump valve on row 7. Install blue airline from the outlet port on the up pressure dump valve on row 7 to the tee installed for that dump valve.

**Step 3:T5 & T6** Route blue and black airline from row 32 to row 20. At row 20, install the black airline in the down pressure air bag & blue airline in the up pressure air bag. Trace airline from row 20 back to row 32 installing tees in each airline at each row unit. Install blue airline from the up pressure air bag at each row to the tee in the up pressure (blue) circuit for that row. Install black airline from the down pressure air bag at each row to the tee in the down pressure (black) circuit for that row. At row 32, cut both airlines to length and install each airline into the matching air bag.

**Step 4:** Install a tee in the T5 airline next to each down pressure dump valve on row 24 and row 28. Install black airline from the outlet port on each down pressure dump valve on row 24 and row 28 to the tee installed for that dump valve. Install a tee in the T6 airline next to the up pressure dump valve on row 26. Install blue airline from the outlet port of the up pressure dump valve on row 26 to the tee.

**Step 5:T3 &T4** Route blue and black airline from row 14 to row 19. At row 19, install the black airline in the down pressure air bag & the blue airline in the up pressure air bag. Trace both airlines back to row 14 installing a tee in each airline at each row. Install blue airline from the up pressure air bag at each row to the tee in the up pressure (blue) circuit for that row. Install black airline from the down pressure air bag at each row to the tee in the down pressure (black) circuit for that row. At row 14, cut both airlines to length and install each airline into the matching air bag.

**Step 6:** Install a tee in the T3 airline next to the down pressure dump valve on row 17. Install black airline from the tee in T3 airline into the outlet port on the down pressure dump valve on row 17. Install a tee in the T4 airline next to the dump valve on row 16. Install blue airline from the tee in T4 airline to the outlet port on the up pressure dump valve on row 16.

**Step 7:S1** Route black airline from the RD port of the 2940-101 compressor housing to the nearest point on the main frame and install a tee. From each side of the tee, route black airline to the inlet port of the down pressure dump valve on row 5 & row 28. (follow the same routing path as the trunk lines) Install a tee into the S1 airline next to the other down pressure dump valves on rows 10 and 24. Route black airline from each tee to the inlet port for that dump valve.

**Step 8:S2** Route blue airline from the RU port of the 2940-101 compressor housing to the nearest point on the main frame & install a tee. Install a 6 inch piece of blue line into one port of tee. Install a second tee on the open end 6 inch piece of blue airline. This will give you 3 open ports on this circuit to use. Route & install blue airline from 2 of those ports to each inlet port on the up pressure dump valve on rows 7 & 26. Route & install blue airline from the remaining port on the tee to the inlet on the up pressure dump valve on row 16.

**Step 9:S3** Route black airline from the WT port of the 2940-101 compressor housing to the inlet port of the down pressure dump valve on row 17.

# 36 Row Dump Valve Diagram

Down  
Pressure  
Dump Valve

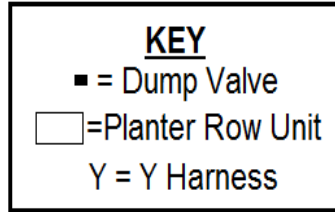
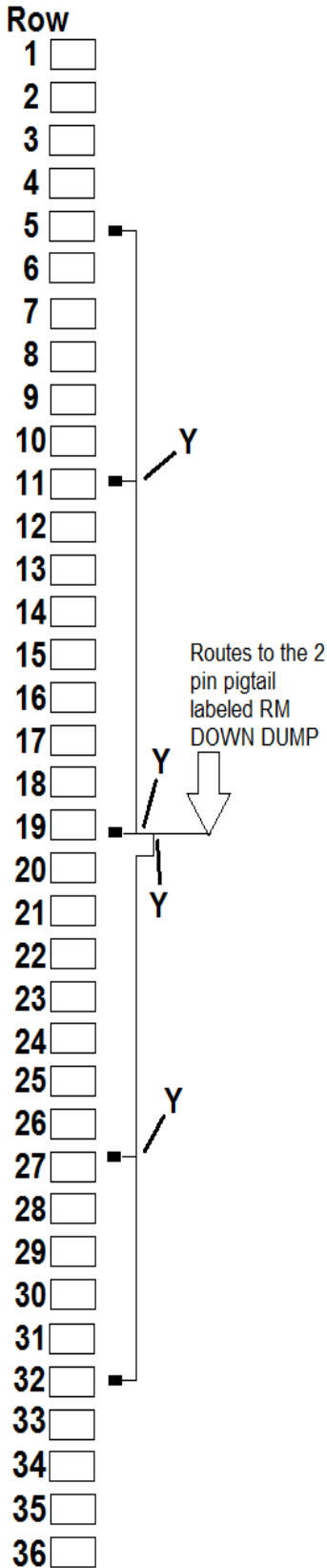

**Step 1:** Install 1 dump valve on each of the following rows: 5, 7, 11, 18, 19, 27, 29, & 32.

**Step 2:** Install the male 12 pin Deutsch connector of the 2940-162 dump valve cable into the **GRAY** female connector on the underside of the 2940-101 compressor housing.

**Step 3:** At row 5's dump valve, connect the 2 pin connector of the dump valve to the mating 2 pin connector of the 2940-156 15ft black dump valve cable & route to the dump valve on row 11 but don't install. At row 32's dump valve, connect the 2 pin connector of the dump valve to the mating 2 pin connector of the 2940-156 15ft black dump valve cable & route to the dump valve on row 27 but don't install.

**Step 4:** Connect the 2 pin cable of the dump valve on row 11 & the cable routed from row 5 in step 3 using a 2940-161 black Y harness. Connect the 2 pin cable of the dump valve on row 27 & the cable routed from row 32 in step 3 using a 2940-161 black Y harness.

**Step 5:** Install a 2940-154 30ft black dump valve harness in the remaining connector of the Y harness at row 11 & route to the dump valve on row 19 but don't install. Install a 2940-154 30ft black dump valve harness in the remaining connector of the Y harness at row 27 & route to the dump valve on row 19 but don't install.

**Step 6:** At row 19, use 2) 2940-161 black Y harnesses to connect the black dump valve cable ran from each wing/side section of the planter (in step 5) and also the dump valve on row 19 so that only 1) 2 pin connector remains.

**Step 7:** Route the appropriate length of black dump valve cable(s) from the open 2 pin connector at row 19 (from step 6) to the 2 pin connector labeled RM DOWN DUMP on the 2940-162 cable from step 2.

**Step 8:** At row 7's dump valve, connect the 2 pin connector of the dump valve to the mating 2 pin connector of the 2940-155 30ft white dump valve cable & route to the dump valve on row 18 but don't install. At row 29's dump valve, connect the 2 pin connector of the dump valve to the mating 2 pin connector of the 2940-155 30ft white dump valve cable & route to the dump valve on row 18 but don't install.

**Step 9:** At row 18, use 2) 2940-159 white Y harnesses to connect the white dump valve cable ran from each wing/side section of the planter (in step 8) & also the dump valve on row 18 so that only 1) 2 pin connector remains.

**Step 10:** Route the appropriate length of white dump valve cable(s) from the open 2 pin connector at row 18 (from step 9) to the 2 pin connector labeled RM UP DUMP on the 2940-162 from step 2.

Up  
Pressure  
Dump Valve

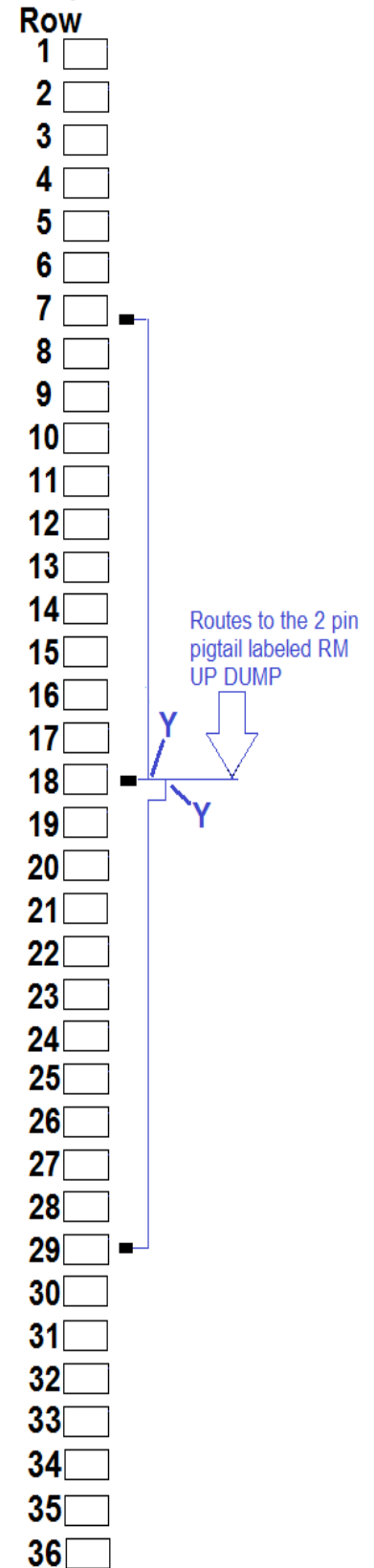

★ Aux 3 & Aux 4 on 2940-162 are not yet used ★

# 36 Row Airline Diagram

**KEY**

- = Dump Valve
- = Planter Row Unit
- T1-6 = Trunk Line
- S1-3 = Supply Line

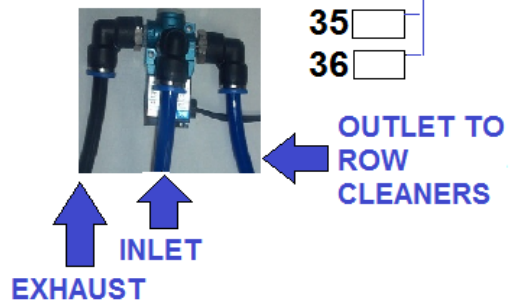
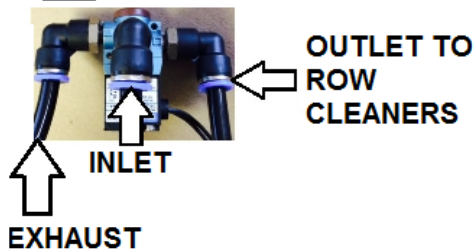
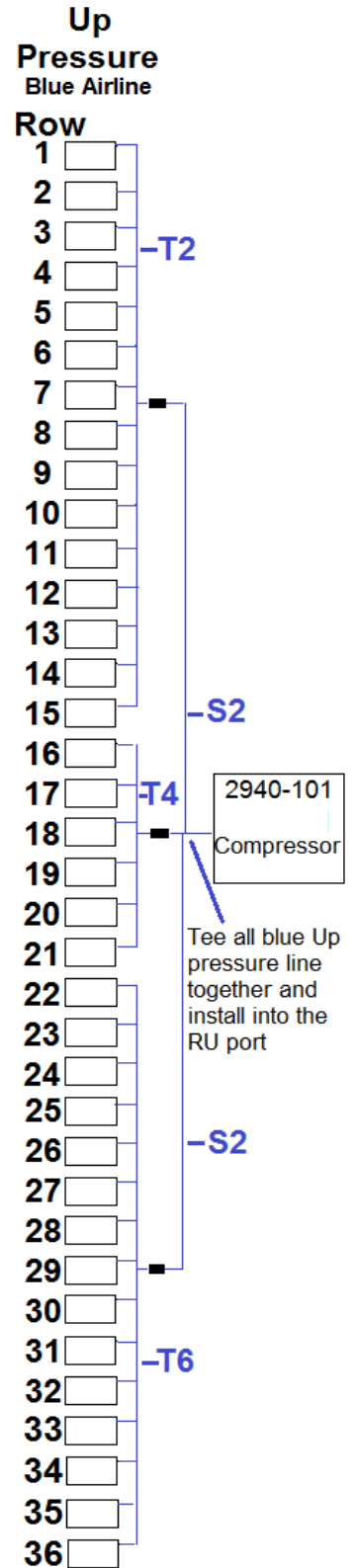
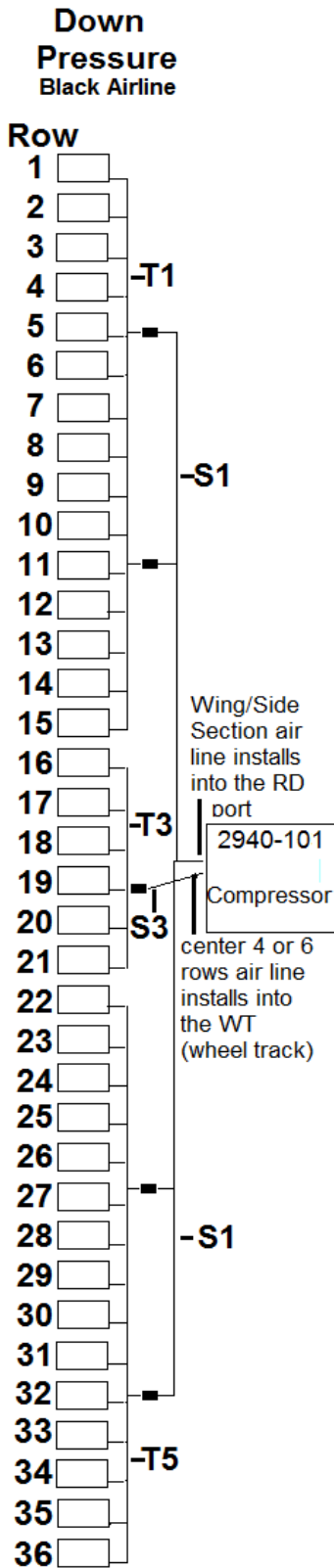

## 36 Row Airline Diagram Con't

**Step 1:T1 & T2** Route blue & black airline from row 1 to row 15. At row 15, install the black airline in the down pressure (larger) air bag & blue airline in the up pressure (smaller) air bag. Trace both airline back to row 1 installing tees in each airline at each row unit. Install blue airline from the up pressure air bag at each row to the tee in the up pressure (blue) circuit for that row. Install black airline from the down pressure air bag at each row to the tee in the down pressure (black) circuit for that row. At row 1, cut both airlines to length & install airline into the matching air bag.

**Step 2:** Install a tee in the T1 airline next to each down pressure dump valve on rows 5 & 11. Install black airline from the outlet port on the down pressure dump valves on rows 5 & 11 to the tee for that dump valve. Install a tee in the T2 airline next to the up pressure dump valve at row 7. Install blue airline from the outlet port on the up pressure dump valve on row 7 to the tee for that dump valve.

**Step 3:T5 & T6** Route blue and black airline from row 36 to row 22. Install each airline into the matching air bag on row 20. Trace both airlines back to row 36 installing tees in each airline at each row. Install blue airline from the up pressure air bag at each row to the tee in the up pressure (blue) circuit for that row. Install black airline from the down pressure air bag at each row to the tee in the down pressure (black) circuit for that row. At row 36, cut both airlines to length & install each airline into the matching air bag.

**Step 4:** Install a tee in the T5 airline next to each down pressure dump valve on rows 27 & 32. Install black airline from the outlet port of the down pressure dump valves on row 27 & 32 to the tee for that dump valve. Install a tee in the T6 airline next to the up pressure dump valve on row 29. Install blue airline from the outlet port of the up pressure dump valve on row 29 to the tee for that dump valve.

**Step 5:T3 & T4** Route blue and black airline from row 16 to row 21. Install each airline at row 21 into the matching air bags. Trace both airlines back to row 16 installing tees in each airline at each row. Install blue airline from the up pressure air bag at each row to the tee in the up pressure (blue) circuit for that row. Install black airline from the down pressure air bag at each row to the tee in the down pressure (black) circuit for that row. At row 16, cut both airlines to length and install each airline into the matching air bag.

**Step 6:** Install a tee in the T3 airline next to the dump valve on row 19. Install black airline from the outlet port of the down pressure dump valve on row 19 to the tee for that dump valve. Install a tee in the T4 airline next to the dump valve on row 18. Install blue airline from the outlet port of the up pressure dump valve on row 18 to the tee for that dump valve.

**Step 7:S1** Route black airline from RD port of the 2940-101 compressor housing to the nearest point on the main frame and install a tee. From each side of the tee, route black airline to the inlet port on the down pressure dump valve on rows 5 and 32. (follow the same routing path as the trunk lines) Install a tee into the S1 airline next to the other down pressure dump valves on rows 11 and 27. Install black airline from the inlet port of each dump valve to the tee for that dump valve.

**Step 8:S2** Route blue airline from the RU port of the 2940-101 compressor housing to the nearest point on the main frame & install a tee. Install a 6 inch piece of blue airline into one port of tee. Install a second tee on the open end 6 inch piece of blue airline. This will give you 3 open ports on this circuit to use. Route & install blue airline from 2 of those ports to each inlet port on the up pressure dump valve on rows 7 & 29. Route & install blue airline from the remaining port on the tee to the inlet port on the up pressure dump valve on row 18.

**Step 9:S3** Route black airline from the WT port of the 2940-101 compressor housing to the inlet port of the down pressure dump valve on row 19.

# 48 Row Dump Valve Diagram

Down  
Pressure  
Dump Valve  
Row

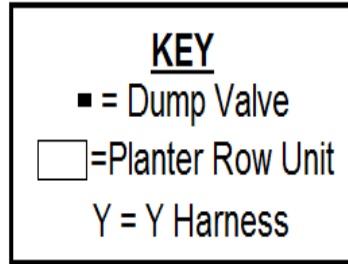
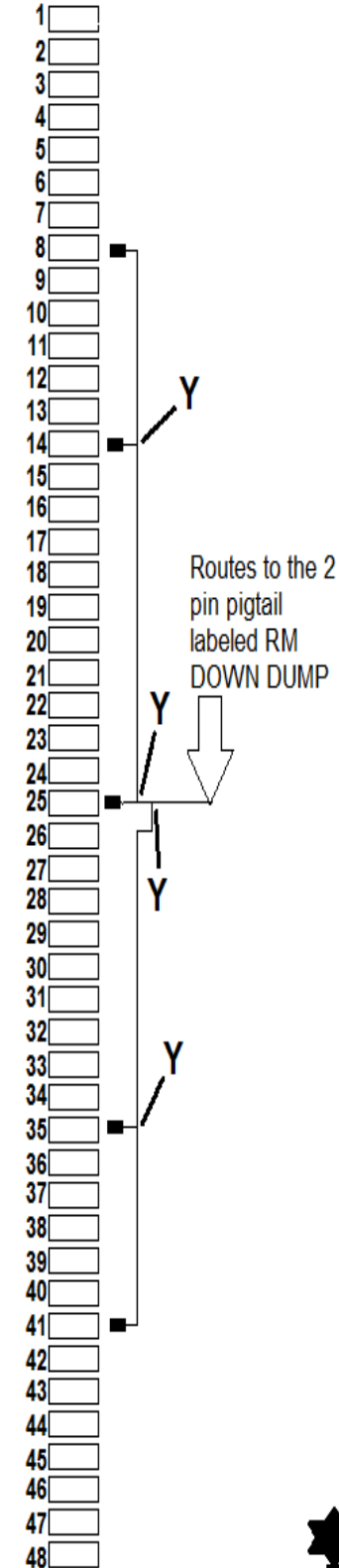

**Step 1:** Install 1 dump valve on each of the following rows: 8, 12, 14, 24, 25, 35, 36, & 41.

**Step 2:** Install the male 12 pin Deutsch connector of the 2940-162 dump valve cable into the **GRAY** female connector on the underside of the 2940-101 compressor housing.

**Step 3:** At row 8's dump valve, connect the 2 pin connector of the dump valve to the mating 2 pin connector of the 2940-156 15ft black dump valve cable & route to the dump valve on row 14 but don't install. At row 41's dump valve, connect the 2 pin connector of the dump valve to the mating 2 pin connector of the 2940-156 15ft black dump valve cable & route to the dump valve on row 35 but don't install.

**Step 4:** Connect the 2 pin cable of the dump valve on row 14 & the cable routed from row 8 in step 3 using a 2940-161 black Y harness. Connect the 2 pin cable of the dump valve on row 35 & the cable routed from row 41 in step 3 using a 2940-161 black Y harness.

**Step 5:** Install a 2940-154 30ft black dump valve harness in the remaining connector of the Y harness at row 14 & route to the dump valve on row 25 but don't. Install a 2940-154 30ft black dump valve harness in the remaining connector of the Y harness at row 35 & route to the dump valve on row 25 but don't install.

**Step 6:** At row 25, use 2) 2940-161 black Y harnesses to connect the black dump valve cable ran from each wing/side section of the planter (in step 5) and also the dump valve on row 25 so that only 1) 2 pin connector remains.

**Step 7:** Route the appropriate length of black dump valve cable(s) from the open 2 pin connector at row 25 (from step 6) to the 2 pin connector labeled RM DOWN DUMP on the 2940-162 cable from step 2.

**Step 8:** At row 12's dump valve, connect the 2 pin connector of the dump valve to the mating 2 pin connector of the 2940-155 30ft white dump valve cable & route to the dump valve on row 24 but don't install. At row 36's dump valve, connect the 2 pin connector of the dump valve to the mating 2 pin connector of the 2940-155 30ft white dump valve cable & route to the dump valve on row 24 but don't install.

**Step 9:** At row 24, use 2) 2940-159 white Y harnesses to connect the white dump valve cable ran from each wing/side section of the plant (in step 8) & also the dump valve on row 24 so that only 1) 2 pin connector remains.

**Step 10:** Route the appropriate length of white dump valve cable(s) from the open 2 pin connector at row 24 (from step 9) to the 2 pin connector labeled RM UP DUMP on the 2940-162 from step 2.

Up  
Pressure  
Dump Valve  
Row

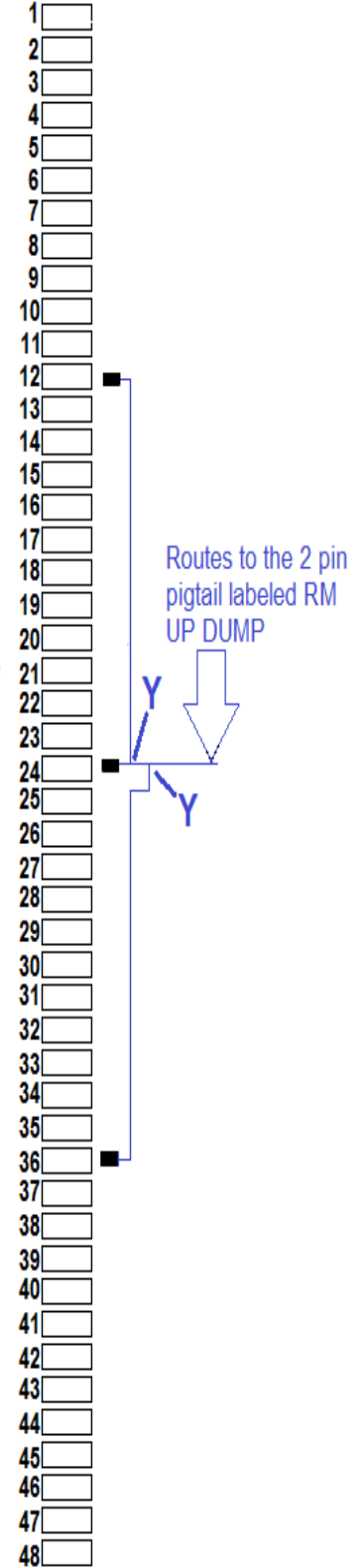

★ Aux 3 & Aux 4 on 2940-162 are not yet used ★

# 48 Row Airline Diagram

**Down**  
Pressure  
Black Airline

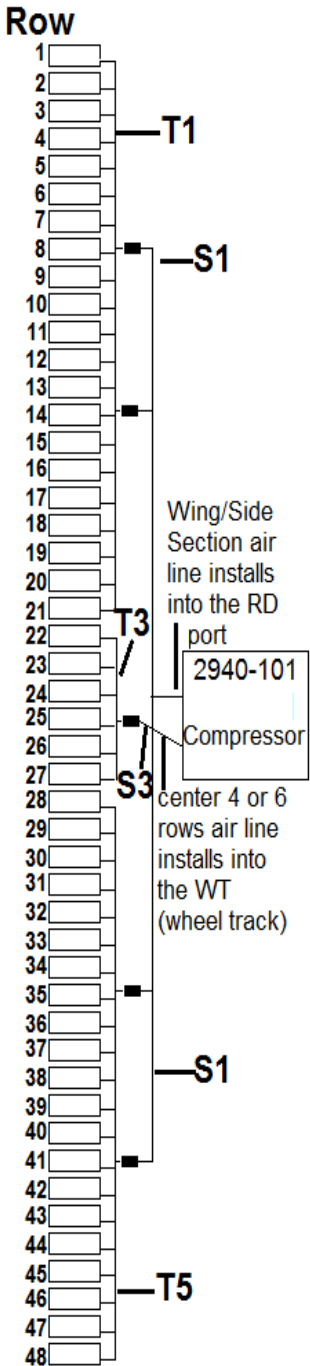

**Up**  
Pressure  
Blue Airline

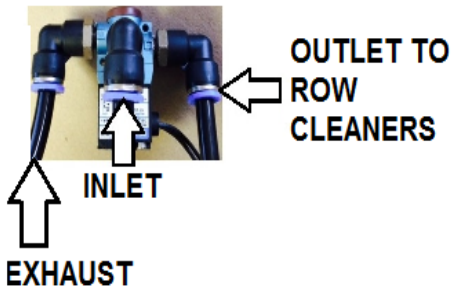
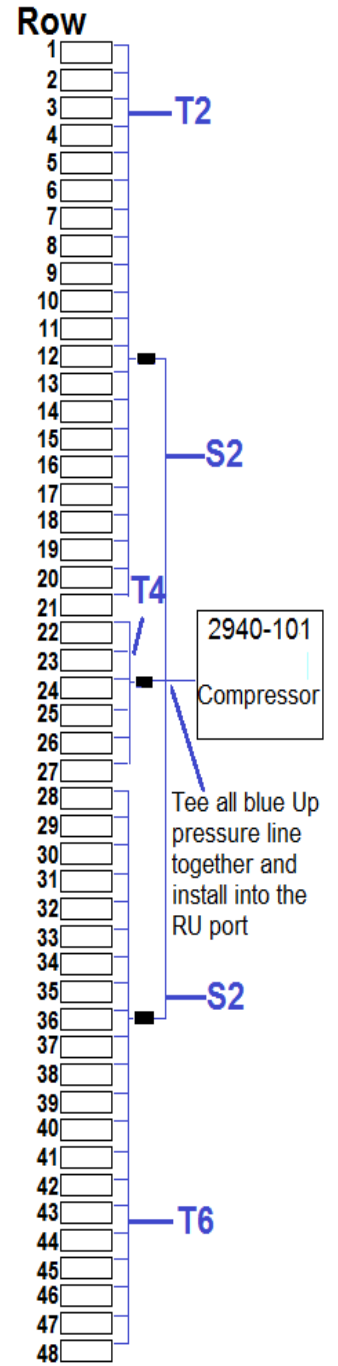

**KEY**

- = Dump Valve
- = Planter Row Unit
- T1-6 = Trunk Line
- S1-3 = Supply Line

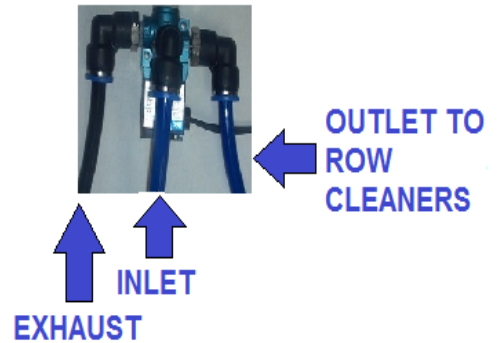

## 48 Row Airline Diagram

**Step 1:T1 & T2** Route blue & black airline from row 1 to row 21. At row 21, install the black airline in the down pressure (larger) air bag & blue airline in the up pressure (smaller) air bag. Trace both airline back to row 1 installing tees in each airline at each row unit. Install blue airline from the up pressure air bag at each row to the tee in the up pressure (blue) circuit for that row. Install black airline from the down pressure air bag at each row to the tee in the down pressure (black) circuit for that row. At row 1, cut both airlines to length & install each airline into the matching air bag.

**Step 2:** Install a tee in the T1 airline next to each down pressure dump valve on rows 8 & 14. Install black airline from the outlet port on the down pressure dump valves on rows 8 & 14 to the tee for that dump valve. Install a tee in the T2 airline next to the up pressure dump valve at row 12. Install blue airline from the outlet port on the up pressure dump valve on row 12 to the tee for that dump valve.

**Step 3:T5 & T6** Route blue & black airline from row 48 to row 28. At row 28, install the black airline in the down pressure (larger) air bag & blue airline in the up pressure (smaller) air bag. Trace both airlines back to row 48 installing tees in each airline at each row unit. Install blue airline from the up pressure air bag at each row to the tee in the up pressure (blue) circuit for that row. Install black airline from the down pressure air bag at each row to the tee in the down pressure (black) circuit for that row. At row 48, cut both airlines to length & install each airline into the matching air bag.

**Step 4:** Install a tee in the T5 airline next to each down pressure dump valve on rows 35 & 41. Install black airline from the outlet port of each down pressure dump valve to each tee for that dump valve. Install a tee in the T6 airline next to the up pressure dump valve at row 36. Install blue airline from the outlet port on the up pressure dump valve on row 36 to the tee for that dump valve.

**Step 5:T3 &T4** Route blue & black airline from row 22 to row 27. At row 27, install the black airline into the down pressure (larger) air bag & the blue airline in the up pressure (smaller) air bag. Trace both airlines back to row 22 installing tees in each airline at each row unit. Install blue airline from the up pressure air bag at each row to the tee in the up pressure (blue) circuit for that row. Install black airline from the down pressure air bag at each row to the tee in the down pressure (black) circuit for that row. At row 22, cut both airlines to length and install each airline into the matching air bag.

**Step 6:** Install a tee in the T3 airline next to the down pressure dump valve on row 25. Install black airline from the outlet port of the dump valve to the tee for that dump valve. Install a tee in the T4 airline next to the up pressure dump valve on row 24. Install blue airline from the outlet port on the up pressure dump valve on row 24 to the tee for that dump valve.

**Step 7:S1** Route black airline from RD port of the 2940-101 compressor housing to the nearest point on the main frame & install a tee. From each side of the tee, route & install black airline to the inlet port on the down pressure dump valve on rows 8 & 41. (follow the same routing path as the trunk lines) Install a tee into the S1 airline next to the other down pressure dump valves on rows 14 & 35. Install black airline from the inlet port of each dump valve to the tee for that dump valve.

**Step 8:S2** Route blue airline from the RU port of the 2940-101 compressor housing to the nearest point on the main frame & install a tee. Install a 6 inch piece of blue line into one port of tee. Install a second tee on the open end 6 inch piece of blue airline. This will give you 3 open ports on this circuit to use. Route & install blue airline from 2 of those ports to each inlet port on the up pressure dump valve on rows 12 & 36. Route & install blue airline from remaining port on the tee to the inlet on the up pressure dump valve on row 24.

**Step 9:S3** Route & install black airline from the WT port of the 2940-101 compressor housing to the inlet of the down pressure dump valve on row 25.



# 54 Row Dump Valve Diagram

Down  
Pressure  
Dump Valve  
Row

- 1
- 2
- 3
- 4
- 5
- 6
- 7
- 8
- 9
- 10
- 11
- 12
- 13
- 14
- 15
- 16
- 17
- 18
- 19
- 20
- 21
- 22
- 23
- 24
- 25
- 26
- 27
- 28
- 29
- 30
- 31
- 32
- 33
- 34
- 35
- 36
- 37
- 38
- 39
- 40
- 41
- 42
- 43
- 44
- 45
- 46
- 47
- 48
- 49
- 50
- 51
- 52
- 53
- 54

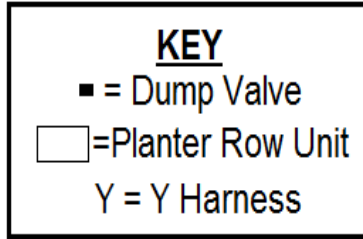

Up  
Pressure  
Dump Valve  
Row

- 1
- 2
- 3
- 4
- 5
- 6
- 7
- 8
- 9
- 10
- 11
- 12
- 13
- 14
- 15
- 16
- 17
- 18
- 19
- 20
- 21
- 22
- 23
- 24
- 25
- 26
- 27
- 28
- 29
- 30
- 31
- 32
- 33
- 34
- 35
- 36
- 37
- 38
- 39
- 40
- 41
- 42
- 43
- 44
- 45
- 46
- 47
- 48
- 49
- 50
- 51
- 52
- 53
- 54

**Step 1:** Install 1 dump valve on each of the following rows: 9, 13, 18, 27, 28, 39, 41, & 48.

**Step 2:** Install the male 12 pin Deutsch connector of the 2940-162 dump valve cable into the **GRAY** female connector on the underside of the 2940-101 compressor housing.

**Step 3:** At row 9's dump valve, connect the 2 pin connector of the dump valve to the mating 2 pin connector of the 2940-156 15ft black dump valve cable & route to the dump valve on row 18 but don't install. At row 48's dump valve, connect the 2 pin connector of the dump valve to the mating 2 pin connector of the 2940-156 15ft black dump valve cable & route to the dump valve on row 39 but don't install.

**Step 4:** Connect the 2 pin cable of the dump valve on row 18 & the cable routed from row 9 from step 3 using a 2940-161 black Y harness. Connect the 2 pin cable of the dump valve on row 39 & the cable routed from row 48 from step 3 using a 2940-161 black Y harness.

**Step 5:** Install a 2940-154 30ft black dump valve harness in the remaining connector of the Y harness at row 18 from step 4 & route to the dump valve on row 28 but don't install. Install a 2940-154 30ft black dump valve harness in the remaining connector of the Y harness at row 39 from step 4 & route to the dump valve on row 28 but don't install.

**Step 6:** At row 28, use 2) 2940-161 black Y harnesses to connect the black dump valve cable ran from each wing/side section of the planter (in step 5) and also the dump valve on row 28 so that only 1) 2 pin connector remains.

**Step 7:** Route the appropriate length of black dump valve cable(s) from the open 2 pin connector at row 28 (from step 6) to the 2 pin connector labeled RM DOWN DUMP on the 2940-162 cable from step 2.

**Step 8:** At row 13's dump valve, connect the 2 pin connector of the dump valve to the mating 2 pin connector of the 2940-155 30ft white dump valve cable & route to the dump valve on row 27 but don't install. At row 41's dump valve, connect the 2 pin connector of the dump valve to the mating 2 pin connector of the 2940-155 30ft white dump valve cable & route to the dump valve on row 27 but don't install.

**Step 9:** At row 27, use 2) 2940-159 white Y harnesses to connect the white dump valve cable ran from each wing/side section of the plant (in step 8) & also the dump valve on row 27 so that only 1) 2 pin connector remains.

**Step 10:** Route the appropriate length of white dump valve cable(s) from the open 2 pin connector at row 27 (from step 9) to the 2 pin connector labeled RM UP DUMP on the 2940-162 from step 2.

Routes to the 2 pin pigtail labeled RM DOWN DUMP

Routes to the 2 pin pigtail labeled RM UP DUMP

★ Aux 3 & Aux 4 on 2940-162 are not yet used ★

# 54 Row Airline Diagram

**Down Pressure**  
Black Airline  
Row

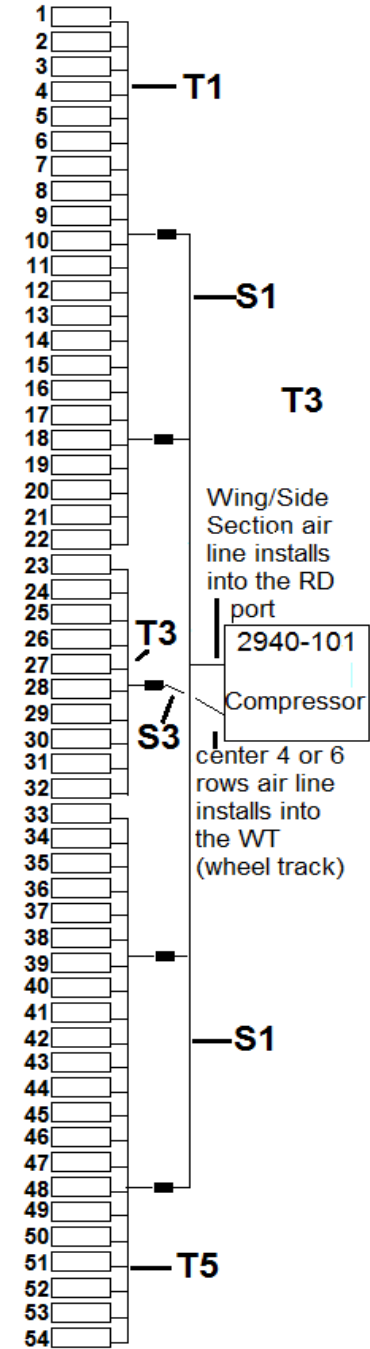

**KEY**

- = Dump Valve
- = Planter Row Unit
- T1-6 = Trunk Line
- S1-3 = Supply Line

**Up Pressure**  
Blue Airline  
Row

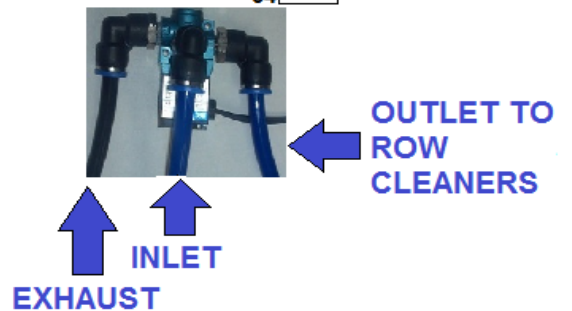
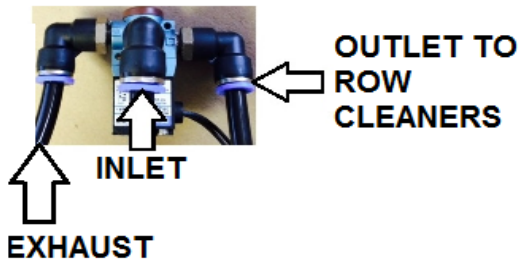
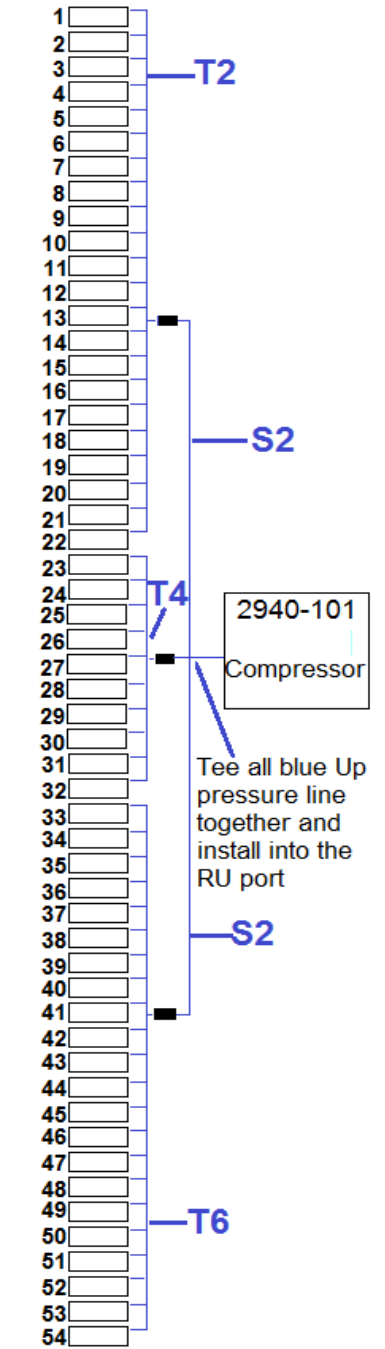

## 54 Row Airline Diagram Con't

**Step 1:T1 & T2** Route blue & black airline from row 1 to row 22. At row 22, install the black airline in the down pressure (larger) air bag & blue airline in the up pressure (smaller) air bag. Trace both airline back to row 1 installing tees in each airline at each row unit. Install blue airline from the up pressure air bag at each row to the tee in the up pressure (blue) circuit for that row. Install black airline from the down pressure air bag at each row to the tee in the down pressure (black) circuit for that row. At row 1, cut both airlines to length & install each airline into the matching air bag.

**Step 2:** Install a tee in the T1 airline next to each down pressure dump valve on rows 10 & 18. Install black airline from the outlet port on the down pressure dump valve on rows 10 & 18 to the tee for that dump valve. Install a tee in the T2 airline next to the up pressure dump valve at row 13. Install blue airline from the outlet port on the up pressure dump valve on row 13 to the tee for that dump valve.

**Step 3:T5 & T6** Route blue and black airline from row 54 to row 33. At row 33, install the black airline in the down pressure (larger) air bag & blue airline in the up pressure (smaller) air bag. Trace both airlines back to row 54 installing a tee in each airline at each row unit. Install blue airline from the up pressure air bag at each row to the tee in the up pressure (blue) circuit for that row. Install black airline from the down pressure air bag at each row to the tee in the down pressure (black) circuit for that row. At row 54, cut both airlines to length & install each airline into the matching air bag.

**Step 4:** Install a tee in the T5 airline next to each down pressure dump valve on rows 39 & 48. Install black airline from the outlet port of each down pressure dump valve on rows 39 & 48 to the tee for that dump valve. Install a tee in the T6 airline next to the up pressure dump valve on row 41. Install blue airline from the outlet port of the up pressure dump valve on row 41 to the tee for that dump valve.

**Step 5:T3 &T4** Route blue and black airline from row 23 to row 32. At row 32, install the black airline in the down pressure (larger) air bag & blue airline in the up pressure (smaller) air bag. Trace both airlines back to row 23 installing a tee in each airline at each row unit. Install blue airline from the up pressure air bag at each row to the tee in the up pressure (blue) circuit for that row. Install black airline from the down pressure air bag at each row to the tee in the down pressure (black) circuit for that row. At row 23, cut both airlines to length and install each airline into the matching air bag.

**Step 6:** Install a tee in the T3 airline next to the down pressure dump valve on row 28. Install black airline from the outlet port of the down pressure dump valve on row 28 to the tee for that dump valve. Install a tee in the T4 airline next to the up pressure dump valve on row 27. Install blue airline from the outlet port of the up pressure dump valve on row 27 to the tee for that dump valve.

**Step 7:S1** Route black airline from RD port of the 2940-101 compressor housing to the nearest point on the main frame & install a tee. From each side of the tee, route & install black airline to the inlet port on the down pressure dump valve on rows 10 & 48. (follow the same routing path as the trunk lines) Install a tee into the S1 airline next to the other down pressure dump valves on rows 18 & 39. Install black airline from tee to the inlet port of each dump valve.

**Step 8:S2** Route blue airline from the RU port of the 2940-101 compressor housing to the nearest point on the main frame & install a tee. Install a 6 inch piece of blue line into one port of tee. Install a second tee on the open end 6 inch piece of blue airline. This will give you 3 open ports on this circuit to use. Route & install blue airline from 2 of those ports to each inlet port on the up pressure dump valve on rows 13 & 41. Route & install blue airline from remaining port on the tee to the inlet port on the up pressure dump valve on row 27.

**Step 9:S3** Route & install black airline from the WT port of the 2940-101 compressor housing to the inlet of the down pressure dump valve on row 28.

# OPERATION

Adjust the residue manager to move crop residue aside and not move any/very little soil. Adjustments to the residue manager may have to be made when changing field conditions, soil type, or amount of residue.

## ROW CLEANER DO'S AND DON'TS

1. **DO NOT** use as a tillage tool; Residue Managers are designed to move crop residue & to break up clods & crust.
2. **DO NOT** operate planter at slow speeds, ground speed affects how aggressive the residue manager wheels are; operate at sufficient speed (refer to your OEM planter manufacturer manual) to maintain good residue flow.
3. **DO NOT** expect 100% of crop residue to be cleared, it is not necessary and would necessitate engaging the soil. The width of path cleared depends on ground conditions, depth setting and ground speed.
4. **DO** expect to see wheels occasionally quit turning, indicates ideal (shallow) setting which is moving very little to no soil.
5. **DO** adjust the toolbar frame height 20"-22" and drawbar correctly. It is very important to ensure planter opener will follow ground contours properly. **See Page 65 for the planter levelness and height.**
6. **DO NOT** run air pressures below 20psi or above 60psi. Full range of travel can be achieved between these settings.
7. **DO** grease the cavity of the bearings regularly. Even though the bearings are sealed, filling the hub keeps moisture, dirt, & debris from entering the hub and ruining the seal. **See pages 68-71 for greasing intervals.**
8. **DO NOT** run the coulter, if equipped, deeper than the disc opener blades. Coulter should be set to run even or slightly above disc opening blades depth.

 **NOTICE:** For proper operation, the planter frame must operate level (fore, aft and side to side) and at the correct height, typically 20"-22". Regularly inspect the residue manager for loose or worn bolts. Repair and replace as needed.



### Overview:

This electronic control system works with a pneumatic system that controls pressure in air bags as well as other air valves in the system on an agricultural application. The air bags provide up and down pressure to mechanical devices that are used on an agricultural implement.

### System Layout:

There are (2) main parts to the control system. The first being a VDM (Valve Drive Module), the role of the VDM is to provide Outputs to control functions of the pneumatic system, it will also provide Inputs to monitor the pneumatic system as well as provide feedback to the operator. The second part is an in-cab switch panel/display (Cab Controller) that allows the operator to control the pneumatic system and monitor its performance.

# Cab Controller Operation

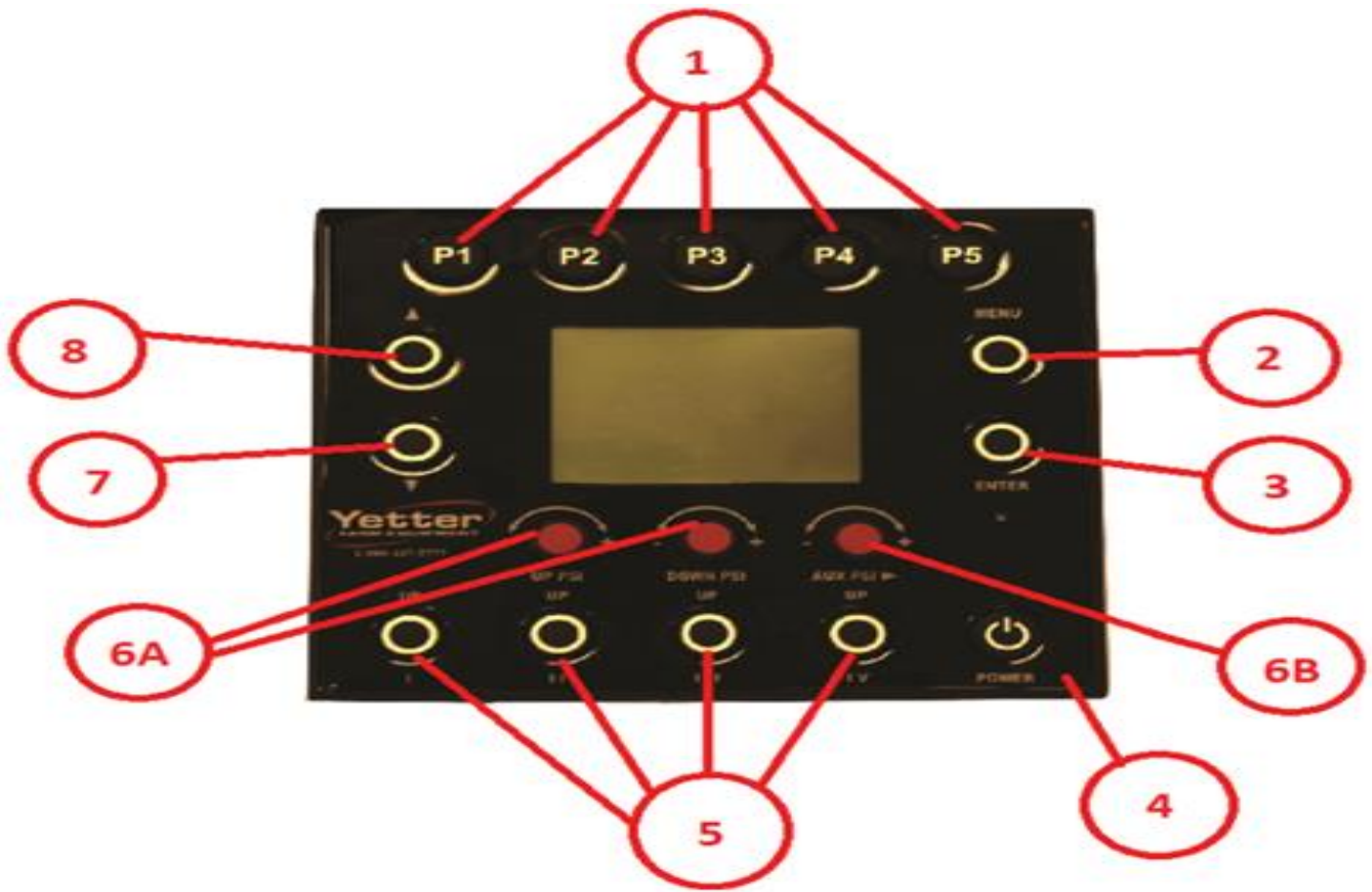

1. **PRESET 1 – 5**-Hold (approximately 5 seconds) to store the commanded pressure settings.
2. **MENU**- Press to display Menu Options. If in Menu Options, pressing Menu will take operator back one screen and eventually to operating screen.
3. **ENTER**- Press to activate/deactivate the system, also used in Menu options to make selections.
4. **POWER**- Press and hold to turn ON/OFF the 2940-100 Cab Controller Display.
5. **UP I-IV**- Press I to raise all row cleaners max travel. Pressing again lowers all row cleaners to preset setting. **Up II-IV are not used!**
6. **A** **PSI UP Encoder (RU)**-rotate to INCREASE/DECREASE Air Pressure on the attachment.  
**PSI DOWN Encoder (RD)**-Rotate to INCREASE/DECREASE Air Pressure on the attachment.
6. **B** **PSI Aux Encoder (WT, A1, A2, A3)** - Push to scroll the cursor. ROTATE to INCREASE/DECREASE air pressure on the cursor selected circuit. (WT, A1, A2, and A3) WT circuit is the only circuit used. A1, A2, & A3 are not utilized at this time.
- ▼ 7. Push to scroll DOWN in the MENU display. Hold this down for 10 seconds to manually dump the water separator. Valve remains open for as long as button is pressed.
- ▲ 8. Push to scroll UP in the MENU display.

# 2940 Air Adjust Cab Controller Operation

## Screen Control and Navigation:

1. **Screen Navigation:** Unless otherwise noted the menu button will always take you back one screen at a time until you arrive at the main menu.
2. To navigate to other screens from the main menu, press menu and use the scroll arrow buttons to select the page you would like to go to and then press enter to navigate there.
3. **Splash Screen (Screen 0):** This screen will be presented after the power button has been pressed. This screen will show the project number and software V/R. It will be displayed for 5 seconds. After that the system will navigate to screen 1.
4. **Main Operating Screen (Screen 1, Pictured below):** This screen is where the air system is monitored and controlled.

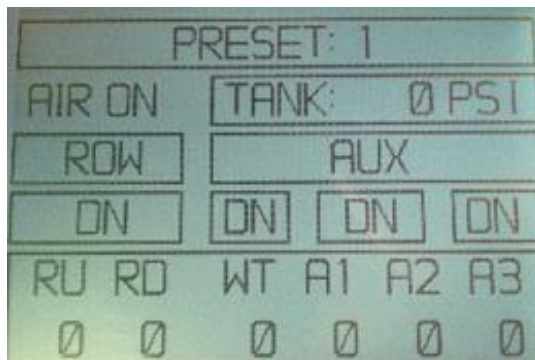

- 4.A The top of the screen shows what preset you are currently using (1-5), if a manual adjustment is made it will display "PRESET (x) MANUAL" until the preset is saved, then it will display PRESET x.
- 4.B There is a field which will display "AIR ON" or "AIR OFF" depending on the status of the air system. Pressing enter will activate/deactivate the AIR ON/OFF. "AIR ON" signifies that the air system is operational and supplying air to the attachment.
- 4.C There is a field which will display the tank pressure in psi "TANK PSI".
- 4.D There are (4) fields which will indicate "UP" or "DOWN" depending on the state of the dump valves that are being controlled.
- 4.E There are (6) fields which define the tools on the system and their pressures. The pressures shown at the bottom of this screen have two modes. In normal operation mode the real pressure feedback from the air system is shown, but if a manual adjustment is made it will show the commanded value for 7.5 seconds, after that delay it will return to displaying the feedback values.

## Operation Settings:

### **"How much Down/Lift Pressure should I be running?"**

The amount of Down/Lift Pressure will vary greatly across soil types, tillage practices, soil moisture, row unit weight and many other variables. Manage the pressure in the Down and/or Lift circuits in order to maintain 90%+ Ground Contact while keeping the pressure between 20-60 psi. The cab Controller will display on the screen, the Tank pressure in psi, and the Down/Lift circuits in psi. A typical starting range for row cleaners only would be 35psi up, 30psi down, and 32psi WT. A typical starting range for row cleaner/coulter combo would be 35psi up, 25 psi down, 27psi WT. The 2940 controller allows for 5 saved settings. Press and hold preset to store setting desired. For no-till increase your down pressure settings and for conventional you will decrease your down pressure setting.

### **Normal operating ranges:**

- Down Pressure Bags: 20-60 psi
- Lift Pressure Bags: 20-60 psi
- Tank Pressure: 85 psi to 105 psi

The tank has a safety relief valve that will automatically exhaust excess pressure in the event that the pressure would exceed 150 psi.

# 2940 Air Adjust Cab Controller Operation

**Main Menu:** This screen will allow you to navigate to the setup and service screens. Selecting EXIT will return you to the main operating screen.

**Setup:** Currently this screen has one option to select the (Dump Valve Delay).

**Dump Valve Delay:** This screen allows you to adjust the dump valve delay time. Press the ENTER button to go into the edit mode, and then adjust the delay time with the SCROLL UP/DOWN buttons. The time value will have .25 second resolution and will be adjustable from 0-60 seconds. Pressing ENTER again will exit the edit mode. Generally, no more than 2.5 seconds is needed.

## **Setting the Dump Valve Delay:**

- Ensure all dump valves and harnesses are plugged in securely, and dump valves are functioning properly
- Adjustments will be made in increments of .25 seconds.
- Proper action should be: when raised, row cleaners come up and stay. When lowered, dump valves will fire, row cleaners should come to ½ travel (or to when the linkage is parallel), at which time the dump valves will close, then row cleaners will fall back to preset pressures slowly.
- Access the dump valve delay screen on your cab controller.
- Adjust to .5 second delay, revert to home screen.
- Press the dump I button and observe row cleaners, it is best to have a second person looking as well.
- Adjust as needed, if they pause just above center, more time is needed. If they fall farther than center, less time is needed.
- When the correct setting is achieved, exit the dump valve delay screen and revert back to the home screen.

## **SEE PAGE 67 TO SEE WHAT SETTING THE DUMP VALVE DELAY SHOULD BE FOR YOUR SITUATION.**

**Service:** This screen has (3) selections to choose from, HOUR METERS, MAINTENANCE, and FAULT STATUS.

**Hour Meters:** This screen will contain (2) hour meters, air compressor hours, which only increments if the compressor is on, and total system hours, which only increments if the air system is enabled (AIR ON). There will also be a field that shows duty cycle; this is a cumulative value calculated by dividing compressor hours by system hours. The percentage shown by the duty cycle should be less than 20%. **If not, perform the leak check on page 66.**

**Maintenance:** This screen is static and has a text description indicating basic maintenance info.

**Fault Status: J1:** This screen contains real time read outs of command and feedback voltage readings for each pin present in the connector labeled J1.

**Fault Status: J2:** This screen contains real time read outs of command and feedback voltage readings for each pin present in the connector labeled J2

**Fault Status: J3:** This screen contains real time read outs of command and feedback voltage readings for each pin present in the connector labeled J3

**Fault Status: J4:** This screen contains real time read outs of command and feedback voltage readings for each pin present in the connector labeled J4

**Warning – Compressor Run Time:** This screen will be displayed if the compressor has been running continuously for 15 minutes. **Evaluate the system for leaks or other issues before continuing.** When problems are fixed, press enter to clear the screen and resume normal operation.

**Warning – Check Fault Screens:** If a fault is detected, this screen will be displayed. Contact a service representative at Yetter, and have the fault screens ready, to review voltage readouts for diagnostics. This warning will remain displayed until the enter button is pressed.

**Air System On:** The state of this displayed text tells the operator if the system is operating or not. The Air System will be On if the ENTER button is pressed on the main operating screen (screen 1). At this point the indicator will turn from red to green. It will maintain On until ENTER is pressed again, turning the indicator back to its original color. Remember to switch the air system off, before removing power to the controller. The system is On when the indicator is green; also the text on the screen will read “AIR ON” (vs. “AIR OFF”).

**Compressor Sump Dump:** This dumps any water that has built up in the compressor tank or water separator. The Compressor Sump Dump valve can also be activated by holding the “Scroll Down” button while on the Main Operating Screen for 10 seconds. The valve will remain open as long as the button is pressed, releasing the button will close the valve.

# 2940 Air Adjust Cab Controller Operation

Appendix

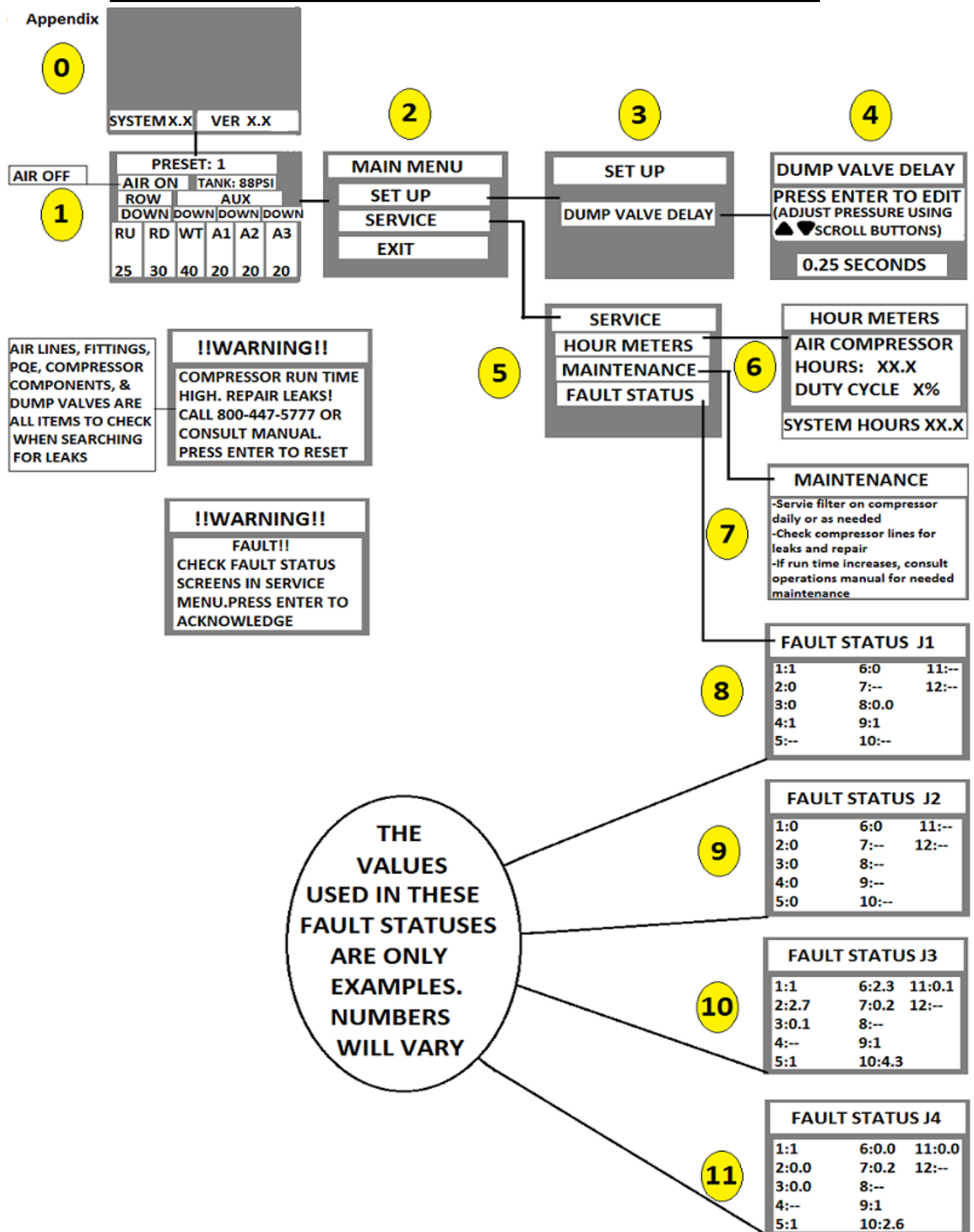



# OPERATION PRECAUTIONS

## STOP



Read this before field operation of the Yetter product.

### -MACHINE OPERATION



**NOTICE:** Failure to properly set the planter frame height and levelness can result in less than successful operation of the planter and the Yetter product and may result in damaged equipment. All operators should read and thoroughly understand the instructions given prior to using the Yetter product.

**DO NOT** use this product if the planter is not adjusted properly!

**Leveling the planter:** Lower the planter frame to operation height (**Usually 20"-22"**). Read the planter operator's manual for recommended setting. Check to be sure the toolbar and row unit parallel arms are level fore and aft. Re-Check when the planter is in the field and has been fully loaded with seed, fertilizer, etc. Also, a field check with a bubble level on the frame should be made of the hitch height to ensure level operation front to back.

It is important for the planter to operate level laterally. Tire pressure must be maintained at pressures specified by the manufacturer.

Field and actual planting conditions change and will dictate planter frame heights. You must ensure that the row unit parallel arms are approximately parallel with the ground.



**NOTICE:** For proper operation of the planter attachments and row units, it is imperative that the planter toolbars and row unit parallel arms be level side-to-side and front-to-rear. The toolbar frame should operate at a 20"-22" height from the planting surface. Check the manufacturer's operator's manual for instructions on how to adjust the frame height and levelness.

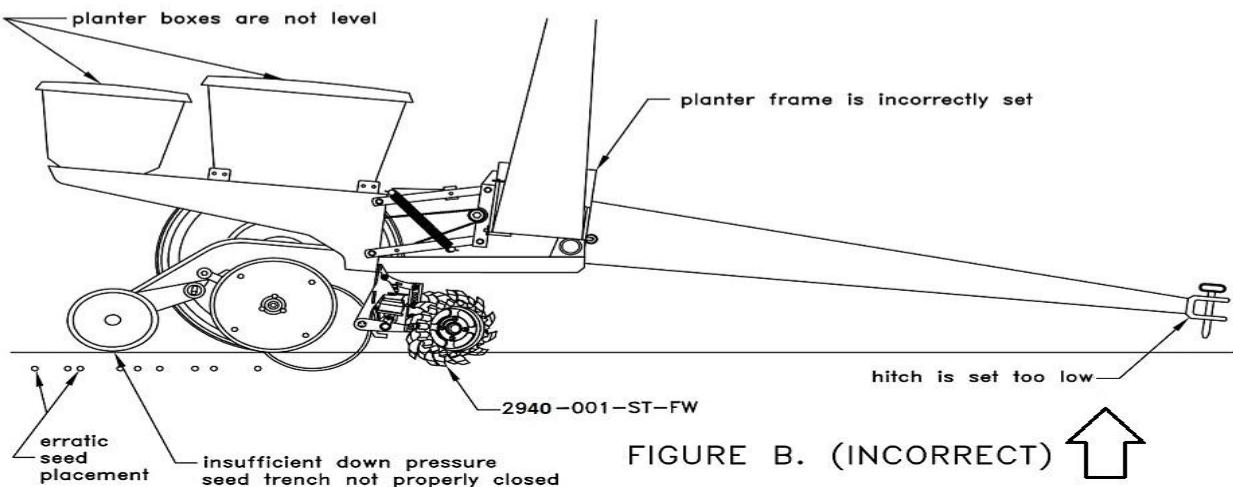
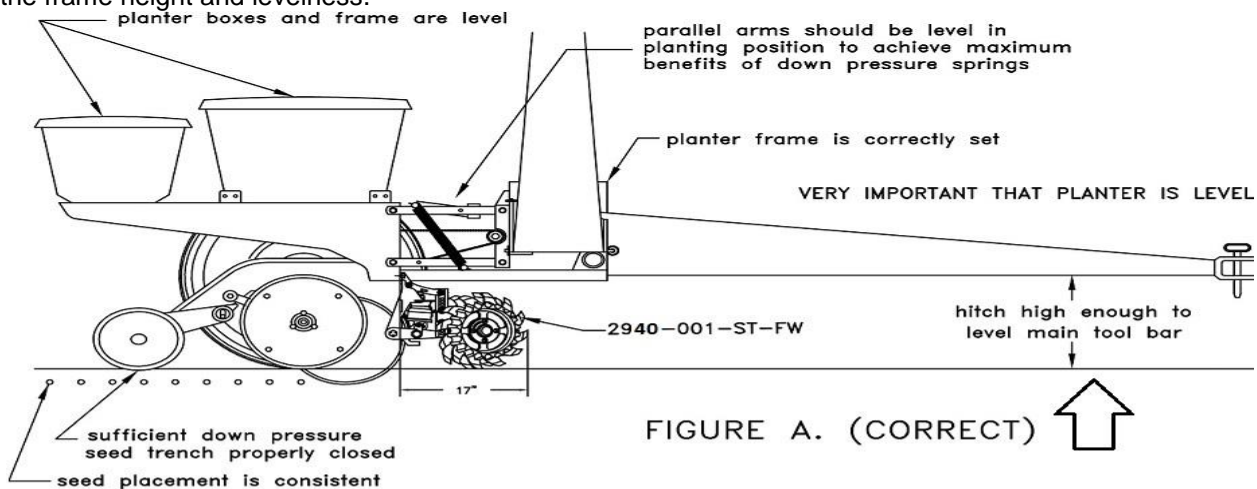

# Pre-Field Operation Guide

## LEAK TESTING

A leak testing procedure should be performed after set-up of the 2940 Air Adjust system is complete. This procedure shall be performed at the beginning of each planting season and every 20 hours of in season use. **In addition, it should be performed if the user notices a lack of air pressure availability or if the compressor is running an abnormally high duty cycle or run time.** It will help keep the duty cycle in check, thus extending the life of the compressor.

**Step 1:** Power the cab controller, turn all pressures (RU, RD, and WT) to 0psi, and press ENTER to activate the system. Make sure the Yetter compressor supplying air to the system has run, built around 95psi of tank pressure, and shut off.

**Step 2:** Check the compressor, water separator assembly, and all compressor housing components for leaks.

**Step 3:** Turn up pressure (RU) to 30psi, exit the tractor cab, and start at the compressor housing checking all blue airline on the RU circuit for leaks. Check all fittings, tees, and dump valves on the RU circuit. Repair leaks as needed & then turn up pressure back to 0psi.

**Step 4:** Turn down pressure (RD) and wheel track (WT) pressure to 30psi, exit the tractor cab, and start at the compressor housing checking all black airlines on the RD & WT circuit for leaks. Check all fittings, tees, and dump valves on the RD & WT circuit. Repair leaks as need.

**Step 5:** With tank pressure at 95psi, compressor not running, and 0psi commanded in all circuits, note the tank psi. Start a stop watch & after 5 minutes, note the tank pressure. If tank pressure drops more the 2psi, check for leaks around/inside the compressor housing. Repair as needed.

**Step 6:** With tank pressure at 95psi, compressor not running, and 30psi commanded in all circuits, no the tank psi. Start a stop watch & after 5 minutes, note the tank pressure. If tank pressure drops more the 2psi, check for leaks on the row cleaner fittings, tees, and dump valves. Repair as needed.

## AIR COMPRESSOR PRE-OPERATING TEST PROCEDURE:

Before beginning this test, run the compressor system leak test and ensure it passes. There should be virtually no leaks in the tank circuit before performing this test.

**Step 1:** Start tractor if not already running. Test results will be skewed if compressor supply voltage is inadequate (13.8 VDC no-load recommended).

**Step 2:** Start a stopwatch at the moment when the Tank pressure reaches the 85psi and the compressor starts running

**Step 3:** Note the time to recover back to 95psi in the tank & the compressor shuts off. If the time recorded is greater than 60 seconds, the compressor or system is either leaking or the compressor is considerably worn. Consider servicing or replacing the compressor before using. If no action is taken and the compressor continues to be used, closely monitor the 2940 Air Adjust system pressure availability.

# Proper Operation Settings

## Dump Valve Delay

To set the dump valve delay, start at the operating screen, press **Menu**, select **Set Up**, press **Enter** to edit, & use the following guide to set to your planter size:

### **Non Split Row Planters**

- 6-12 row planters - .5 seconds
- 16-24 row planters - .75-1.5 seconds
- 32-36 row planters - 1.75 – 2 seconds
- 48-54 row planters - 2.25-2.5 seconds

### **Split Row Planters**

- 6/11, 6/12, 8/15, or 8/16 planters - .5 - .75 seconds using only corn rows, .75 - 1.5 seconds when using all rows
- 12/23 or 12/24 planters - .5 - .75 seconds using only corn rows, 1.75 – 2 seconds when using all rows
- 16/31 or 16/32 planters - .75 – 1 seconds using only corn rows, 2 - 2.25 seconds when using all rows

## Air Pressure Settings

### **Residue Managers Only**

A common question is “What pressures should I start out at?” A good starting pressure setting would be 35psi Up Pressure, 30psi Down Pressure, & 32psi Wheel Track(WT). This particular setting will give each row cleaner a nice sturdy float. If this pressure setting doesn’t remove enough residue or trenches/digs furrows, adjust the settings accordingly until the row cleaner is doing exactly what you want it to do. If the row cleaner is trenching, lessen the down pressure or increase the up pressure. If not enough residue is removed, lessen the up pressure or increase the down pressure. Once a setting is found, hold the desired preset button (P1-P5) until saved. Each field may require a different setting even though field conditions seem the same. For example, if you use a setting for one no-till field planting corn in soybean residue, you may find that the setting used for the next field planting corn in soybean residue in no-till conditions may be different. The reason may be the amount of residue, soil types, moisture variation, etc.

### **Residue managers/Coulter Combos**

A common question is “What pressures should I start out at?” A good starting pressure setting would be 35psi Up Pressure, 25psi Down Pressure, & 27psi Wheel Track (WT). This particular setting will give each row cleaner a nice sturdy float. If this pressure setting doesn’t remove enough residue or trenches/digs furrows, adjust the settings accordingly until the row cleaner is doing exactly what you want it to do. If the row cleaner is trenching, lessen the down pressure or increase the up pressure. If not enough residue is removed, lessen the up pressure or increase the down pressure. Once a setting is found, hold the desired preset button (P1-P5) until saved. Each field may require a different setting even though field conditions seem the same. For example, if you use a setting for one no-till field planting corn in soybean residue, you may find that the setting used for the next field planting corn in soybean residue in no-till conditions may be different. The reason may be the amount of residue, soil types, moisture variation, etc.

# Maintenance

## BEARING ASSEMBLY AND LUBRICATION

### Practice Safety

Understand and practice safe service procedures before doing work. Follow ALL the operating, maintenance and safety information in the equipment operator manual. Clear the area of bystanders, especially small children, when performing any maintenance or adjustments. Keep work area clean and dry. Use adequate lighting for the job. Use only tools, jacks and hoists of sufficient capacity for the job. Never lubricate, service, or adjust machine while it is moving. Keep hands, feet, and clothing from power-driven moving and rotating parts. Disengage all power and operate controls to relieve pressure. Lower equipment to the ground and stop the engine. Remove the key. Wait for all moving parts to stop before servicing, adjusting, repairing or unplugging. Securely support any machine elements with blocks or safety stands that must be raised for service work. Keep all parts in good condition and properly installed. Fix damaged equipment immediately. Replace worn or broken parts. Remove any buildup of grease, oil, or debris. Make sure all guards are in place and properly secured when maintenance work is completed.

### Assembly

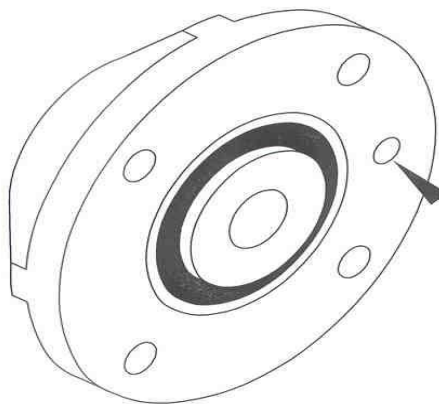

I190-1

ALIGN GREASE FITTING HOLES.

ALIGN THE HUB CAP GROOVE, WITH THE WHEEL SLOT AND GREASE FITTING

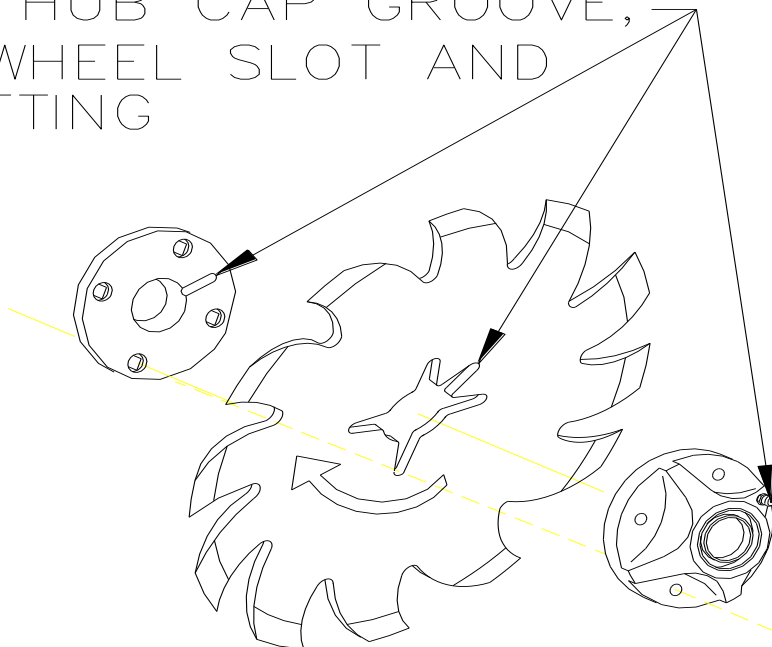

**Be certain to align the grease fitting with the slot in the wheel and the hubcap so that the grease can flow freely.**

# Maintenance

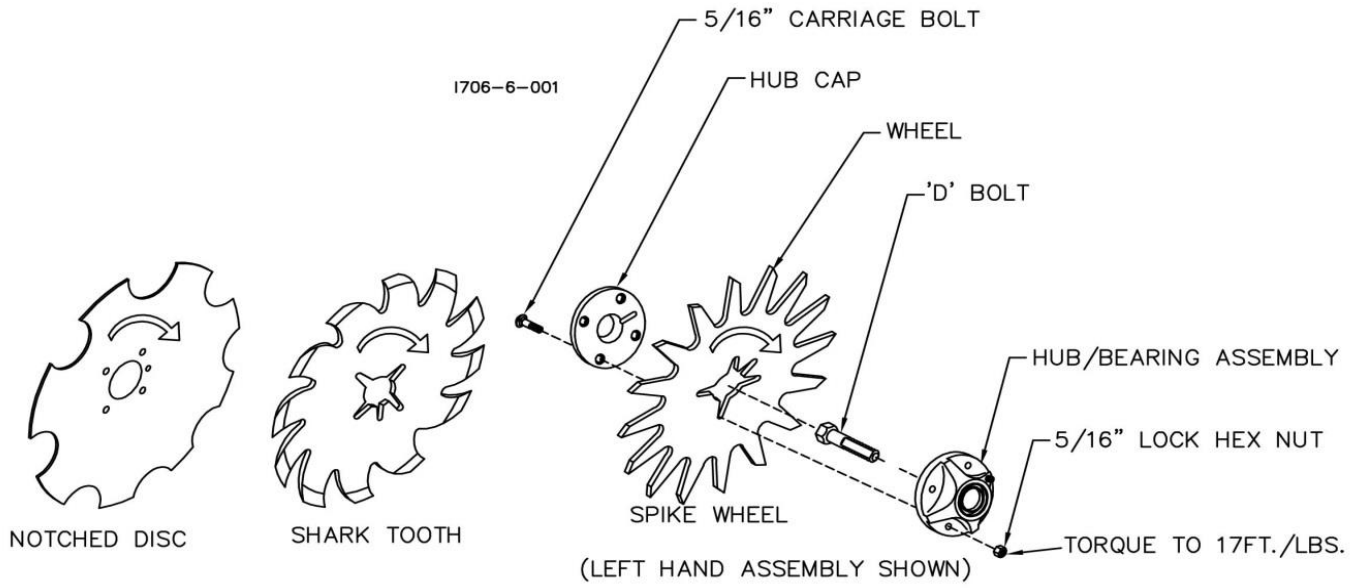

Grease must fill this  
Hubcap cavity.

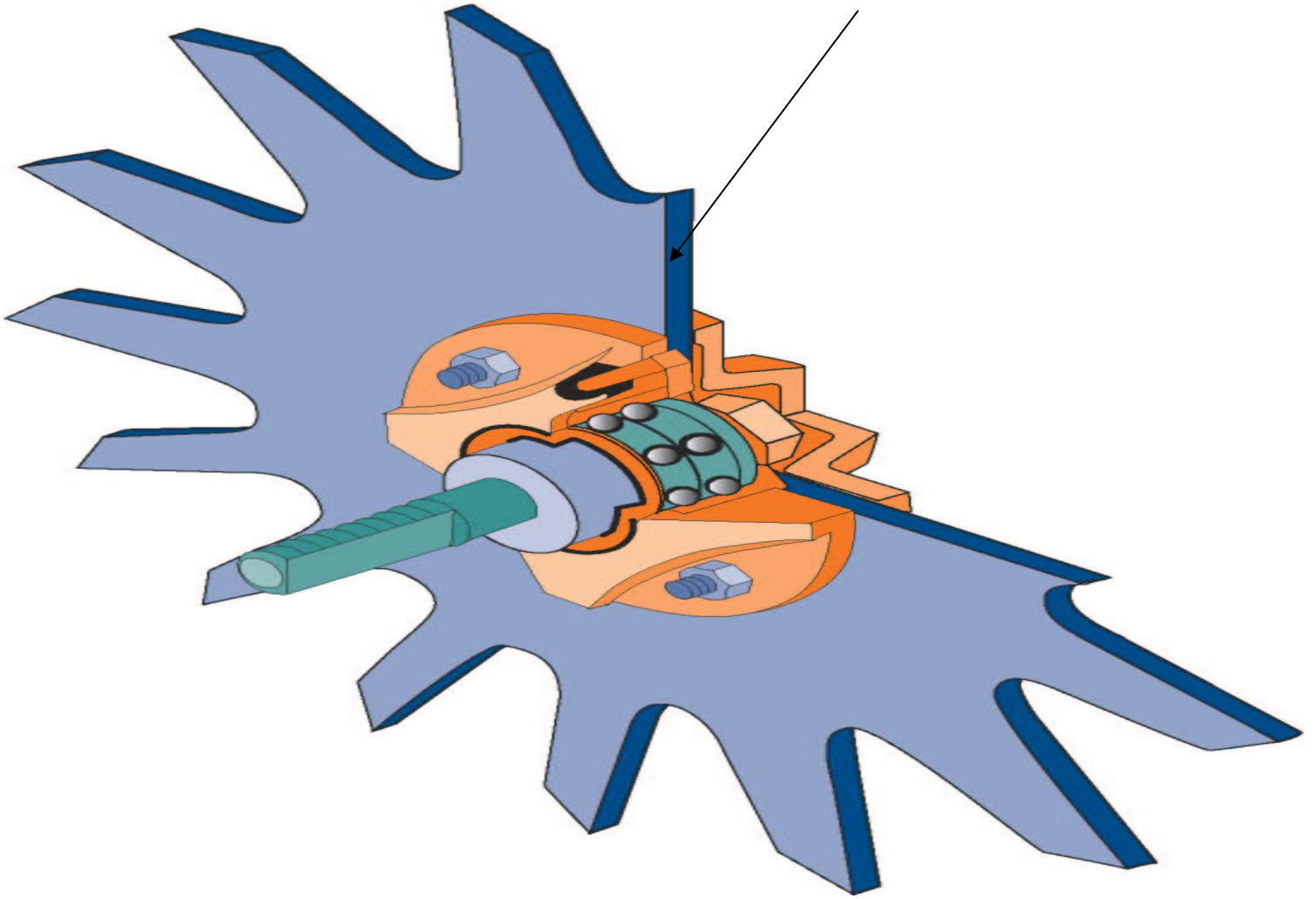

# MAINTENANCE

## Lubrication



**CAUTION:** To help prevent serious injury or death to you or others caused by unexpected movement, service machine on a level surface. Lower machine to ground or sufficiently lock or block raised machine before servicing. If machine is connected to tractor, engage parking brake and place transmission in "PARK", shut off engine and remove key. If machine is detached from tractor, block wheels and use shop stands to prevent movement.



**CAUTION:** Do not clean, lubricate, or adjust machine while in motion.

Use grease based on NLGI consistency numbers and the expected air temperature range during the service interval.

Use a **multi-purpose lithium, water resistant, moderate speed, and NLGI grade #2** grease. Other greases may be used if they meet the following **NLGI Performance Classification: GC-LB**

**Some types of grease thickener are not compatible with others. Consult your grease supplier before mixing different types of grease.**

## Alternative Lubricants

Conditions in certain geographical areas may require special lubricants and lubrication practices which do not appear in the operator's manual. If there are any questions, consult Yetter Manufacturing Co. to obtain latest information and recommendation.

<b>PART #</b>	<b>DESCRIPTION</b>	<b>OUNCES OF GREASE</b>
2967-404	13" TAPER TOOTH R.M. WHEEL	1.12 OZ
2967-602	13" SHARK TOOTH R.M. WHEEL	1.12 OZ
2967-186	FLOATER WHEEL KIT W/R.M. WHEEL	2.08 OZ
2967-596	HEAVY DUTY OR BEVEL R.M. WHEEL W/ FLOATER WHEEL KIT	2.40 OZ

## Storing Lubricants

Your machine can operate at top efficiency only if clean lubricants are used. Use clean containers to handle all lubricants. Store them in an area protected from dust, moisture and other contaminants.

# MAINTENANCE

## Lubrication Symbols



Lubricate with grease at hourly interval indicated on symbol.

## Lubrication Intervals

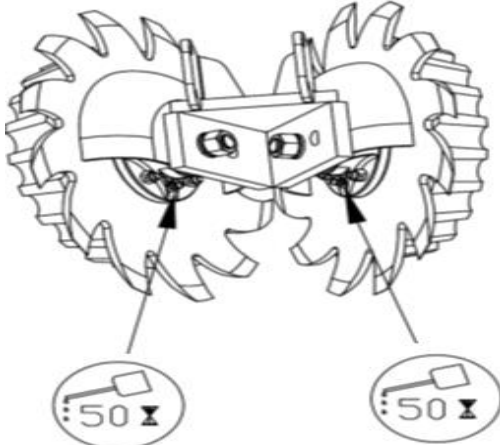

Grease Zerk on the Hub

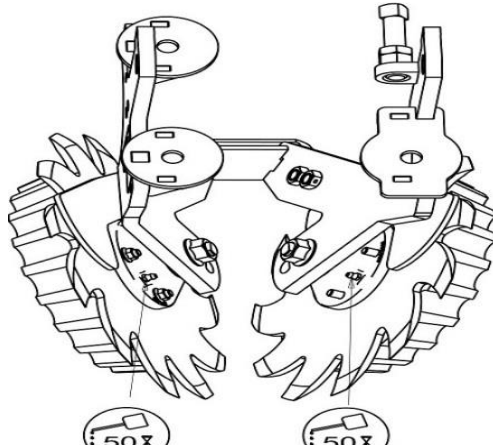

Grease Zerk on Hub

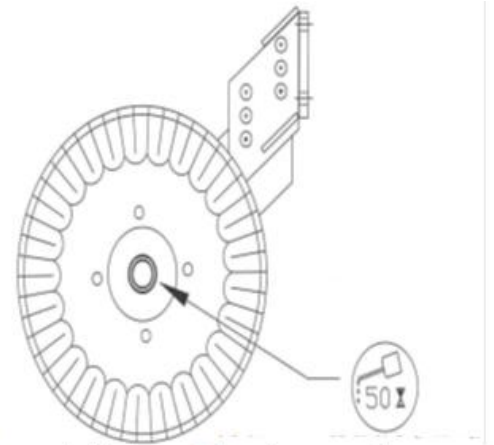

Repack Hub and bearings each season

**The recommended service intervals are based on normal conditions; severe or unusual conditions may require more frequent lubrication.**

- Perform each lubrication and service procedure at the beginning and end of each season.
- Clean grease fittings before using grease gun, to avoid injecting dirt and grit into the bearing.
- Replace any lost or broken fittings immediately. If a fitting fails to take grease, remove and clean thoroughly.
- Replace fitting if necessary. Also check for failure of adjoining parts.

## BEARING REPLACEMENT INSTALLATION

1. When assembling the spoke wheels, bearing assembly and hubcap, be sure to align the grease transfer hole in the spoke wheel with the groove in the hubcap and hole in the hub to allow grease passage.
2. Assemble the wheels, hubs and caps.
3. Grease the wheel/hub/bearing assembly.

## Storing the Equipment

Store the machine in an area away from human activity

Store the machine in RAISED position.

Install service locks on all wheel cylinders.

At the end of the season, the machine should be thoroughly inspected and prepared for storage. Repair or replace any worn or damaged components to prevent down time at the start of the next season. Store the machine under cover with all parts in operating condition.

- Clean machine thoroughly to remove all dirt, debris, and crop residue, which would hold moisture and cause rusting.
- Inspect machine for worn or broken parts. See your Yetter Farm Equipment dealer during the off-season so that parts or service can be acquired when machine is not needed in the field.
- Lubricate bearings as outlined in the Lubrication section.
- Paint all parts which are chipped or worn and require repainting.
- Store machine in a clean, dry place with the planting unit out of the sun.
- If the machine cannot be stored inside, cover with a waterproof tarpaulin and tie securely in place.
- Do not allow children to play on or around the machine.



# AIR BAG REPLACEMENT

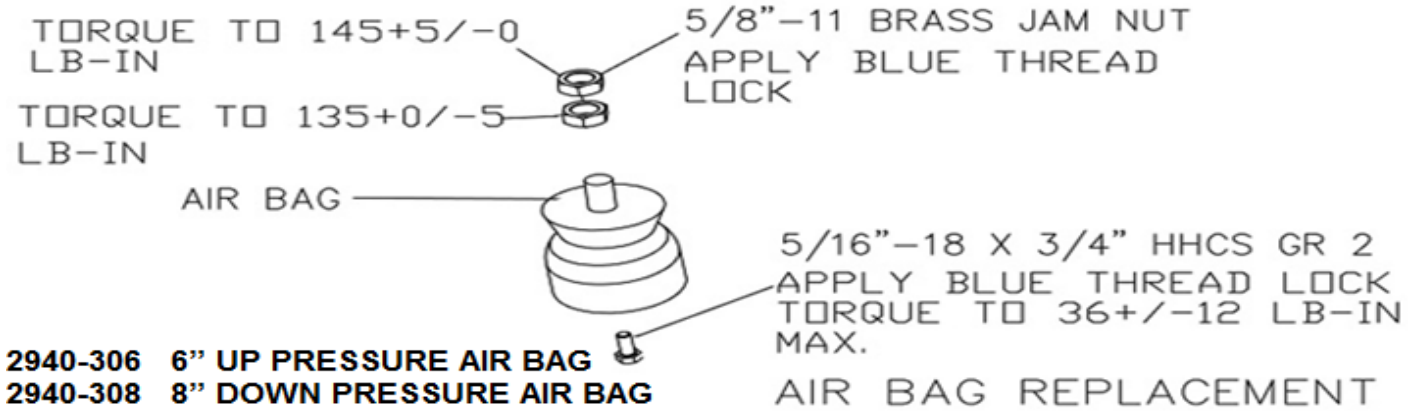

## Parts Identification

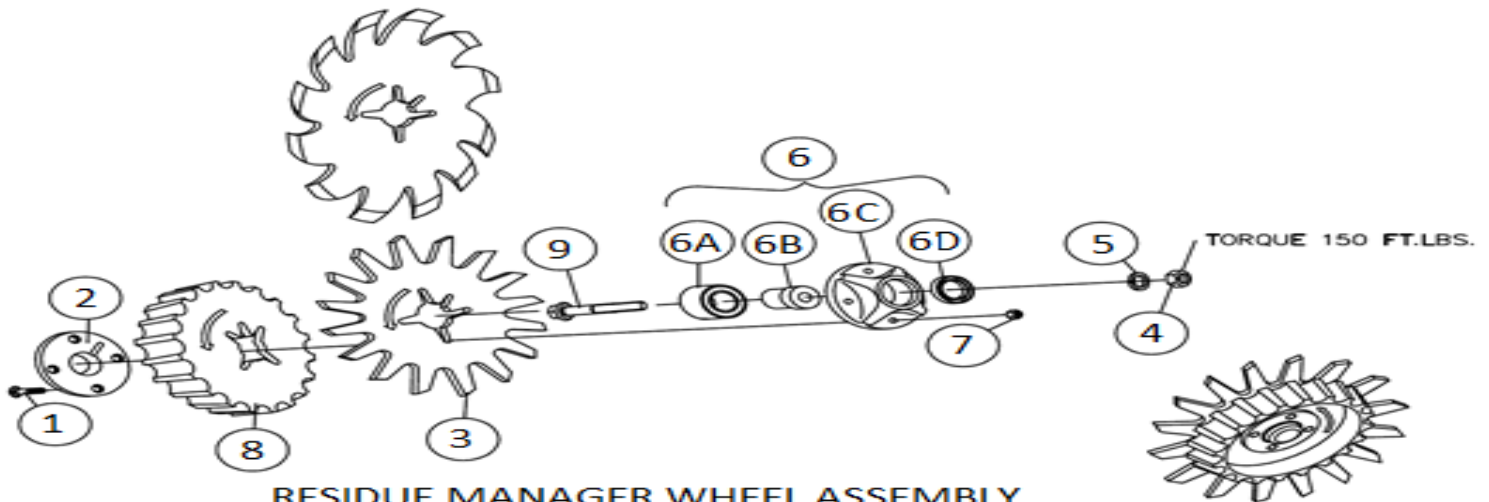

**RESIDUE MANAGER WHEEL ASSEMBLY  
(1 WHEEL ASSEMBLY)**

DET	QTY	PART NO.	DESCRIPTION
1	4	2505-207	5/16-18 X 1 1/4 CAR BLT GR5
	4	2505-208	5/16-18 X 1 1/2 CAR BLT GR5 (FOR USE WITH HEAVY DUT WHEELS)
	4	2505-209	5/16-18 X 1 3/4 CAR BLT GR5 (FOR USE WITH FLOATER WHEEL)
2	1	2965-352	HUB CAP CASTING, 4 BOLT, BLACK
3	1	2967-404	13" TAPER TOOTH SPOKE WHEEL
	1	2967-596	3/8 TAPER TOOTH SPOKE WHEEL
	1	2967-602	13" SHARK TOOTH WHEEL
	1	6200-350	13" BEVELED WHEEL, LH
	1	6200-351	13" BEVELED WHEEL, RH
4	1	2520-452	5/8-11 HEX NUT
5	1	2525-451	5/8 LOCKWASHER
6	1	2965-128	HUB AND BEARING ASSEMBLY, 4 BOLT
6A	1	2570-594	BEARING, 2 ROW NTN# DF0654L
6B	1	2570-715	BEARING INSERT, TRASHMASTER
6C	1	2965-351	HUB CAST, MACHINED, 4 BOLT
	1	2533-110	1/4" SELF TAP ZERK (NOT SHOWN)
6D	1	2550-052	SEAL, CR# 13548
7	4	N10213	5/16-18 HEX FLANGE SERRATED NUT
8	1	2967-555	FLOATER WHEEL
9	1	2570-740	D-BOLT, FLGD, 5/8-11 X 2.812" GR 8

# PARTS IDENTIFICATION

2940-001-ST-FW

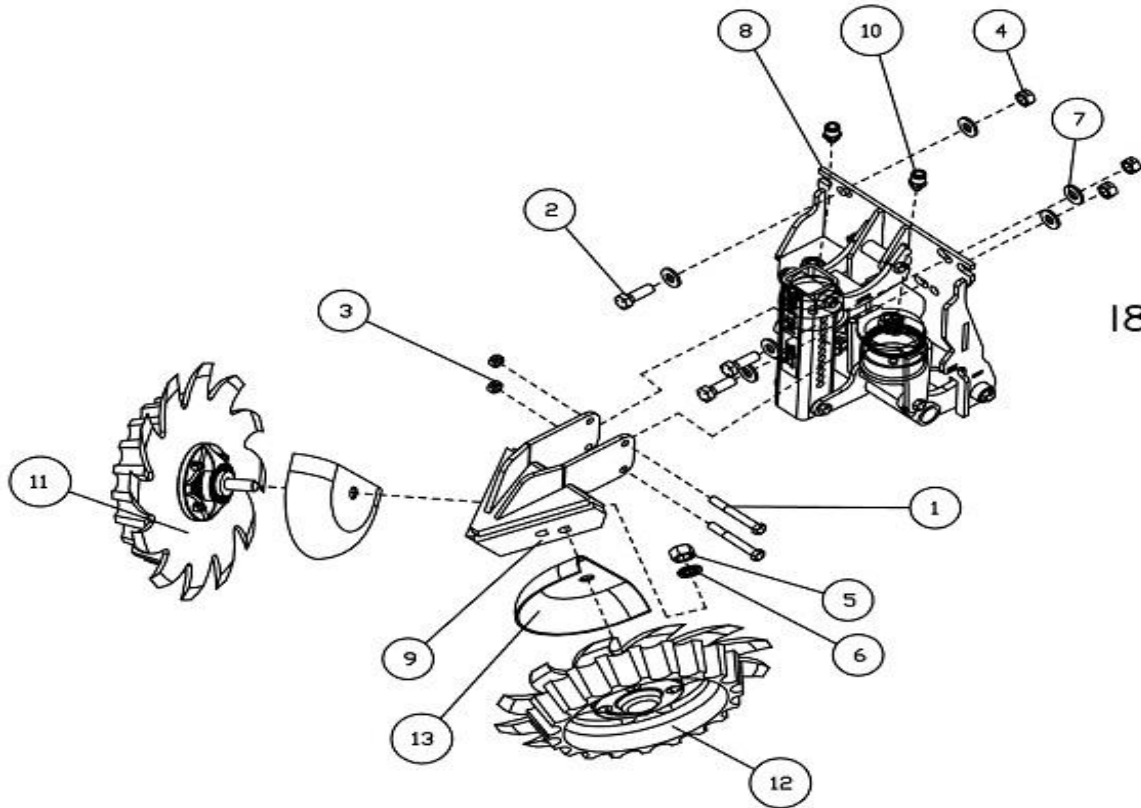

1818-1

ITEM	QTY	PART NO.	DESCRIPTION
1	2	2502-246	3/8-16 X 3 HHCS GR5 ZP
2	3	2502-294	1/2-13 X 1-1/2 HHCS GR5 YD
3	2	2520-255	3/8-16 LOCK HEX NUT ZP
4	3	2520-357	1/2-13 LOCK HEX NUT ZP
5	2	2520-452	5/8-11 HEXNUT ZP
6	2	2525-451	5/8 MED LOCKWASHER ZP
7	6	2526-355	1/2 FLAT WASHER HARD'ND ZYD
8	1	2940-190	PNEUMATIC R.M. MOUNT ASSEMBLY
9	1	2940-215	AIR ADJUST WIDE STEM W.A.
10	2	2940-339	3/8 PUSH CONNECT STRAIGHT 1/8 NPT MALE THREAD
11	1	2966-140	SPOKE WHEEL ASSY, RH, 3" D-BOLT
		2966-140-BW	BEVEL WHEEL ASSY, RH, 3" D-BOLT
		2966-140-BW-FW	BEVEL WHEEL ASSY, RH, 3" D-BOLT FLT WHL
		2966-140-FW	SPOKE WHEEL ASSY, RH, 3" D-BOLT FLT WHL
		2966-140-HD	HD SPOKE WHEEL ASSY, RH, 3" D-BOLT
		2966-140-HD-FW	HD FW SPOKE WHEEL ASSY, RH, 3" D-BOLT
		2966-140-ST	SHARKTOOH ASSY, RH, 3" D-BOLT
		2966-140-ST-FW	SHRKTH ASSY,RH,3"D-BOLT FLT WL
12	1	2966-141	SPOKE WHEEL ASSY, LH, 3" D-BOLT
		2966-141-BW	BEVEL WHEEL ASSY, LH, 3" D-BOLT
		2966-141-BW-FW	BEVEL WHEEL ASSY, LH, 3" D-BOLT FLT WHL
		2966-141-FW	SPOKE WHEEL ASSY, LH, 3" D-BOLT FLT WHL
		2966-141-HD	HD SPOKE WHEEL ASSY, LH, 3" D-BOLT
		2966-141-HD-FW	HD FW SPOKE WHEEL ASSY, LH, 3" D-BOLT
		2966-141-ST	SHARKTOOH ASSY, LH, 3" D-BOLT
		2966-141-ST-FW	SHRKTH ASSY,LH,3"D-BOLT FLT WL
13	2	2967-392	SHIELD, RM COMBO-PAINTED

**MANUFACTURED 10/2013-PRESENT**

# PARTS IDENTIFICATION

2940-001-ST-FW

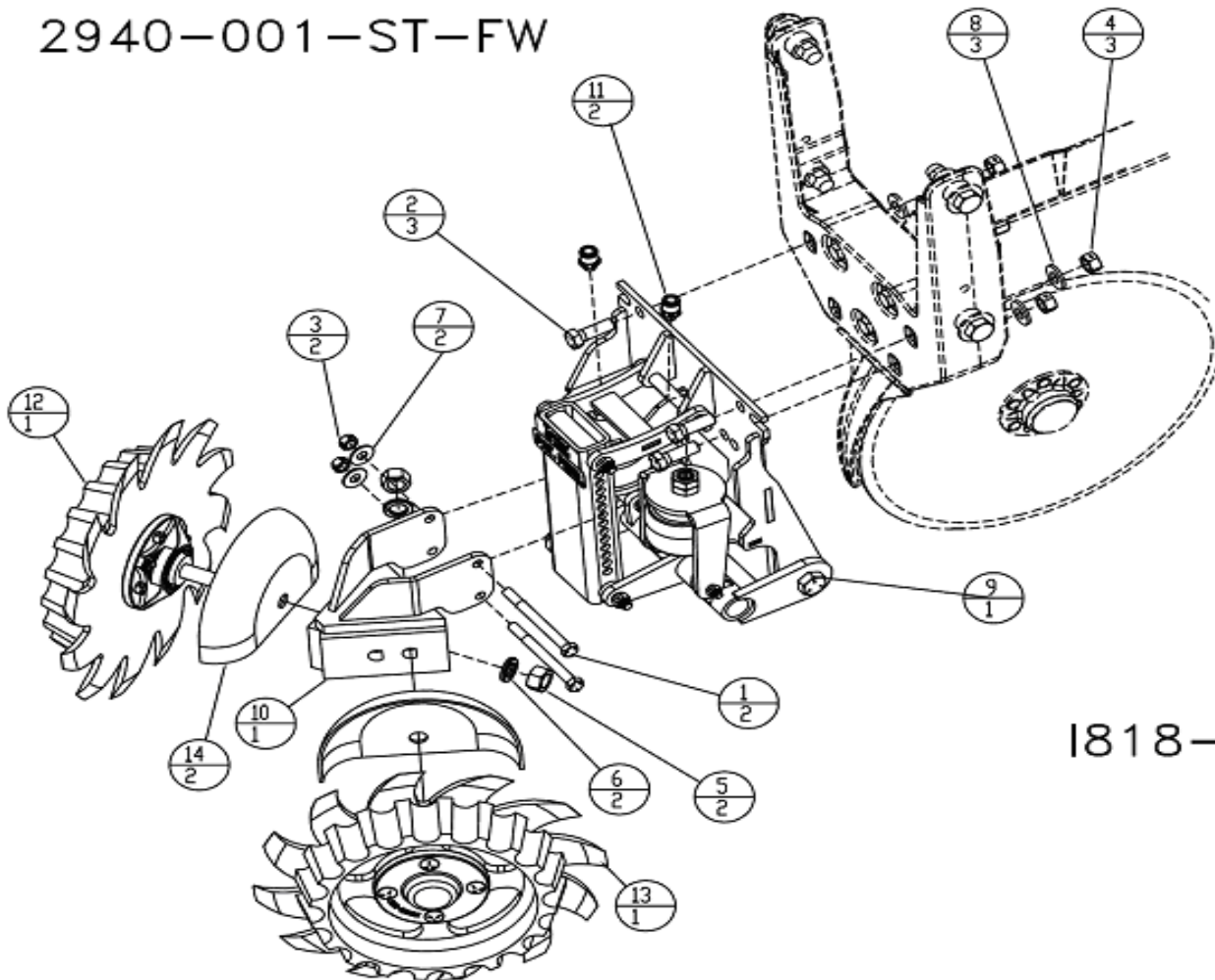

1818-1

ITEM	QTY	PART NO.	DESCRIPTION
1	2	2502-259	3/8-16 x 4-1/4 HHCS GR 5 ZP.
2	3	2502-294	1/2-13 X 1-1/2 HHCS GR5 ZP
3	2	2520-255	3/8-16 LOCK HEX NUT ZP.
4	3	2520-357	1/2-13 LOCK HEX NUT ZP
5	2	2520-452	5/8-11 HEXNUT ZP
6	2	2525-451	5/8 MED. LOCKWASHER ZP.
7	2	2526-251	3/8 STANDARD FLATWASHER ZP
8	3	2526-355	1/2 FLAT WASHER HARD'ND ZP
9	1	2940-140	PNEUMATIC R.M. MOUNT ASSEMBLY
10	1	2940-200	AIR ASSIST STEM W.A.
11	2	2940-339	3/8 PUSH CONNECT STRAIGHT 1/8 NPT MALE THREAD
12	1	2966-140	SPOKE WHEEL ASSY, RH, 3" D-BOLT
	1	2966-140-BW	BEVEL WHEEL ASSY, RH, 3" D-BOLT
	1	2966-140-BW-FW	BEVEL WHEEL ASSY, RH, 3" D-BOLT FLT WHL
	1	2966-140-FW	SPOKE WHEEL ASSY, RH, 3" D-BOLT FLT WHL
	1	2966-140-HD	HD SPOKE WHEEL ASSY, RH, 3" D-BOLT
	1	2966-140-HD-FW	HD FW SPOKE WHEEL ASSY, RH, 3" D-BOLT
	1	2966-140-ST	SHARKTOOH ASSY, RH, 3" D-BOLT
	1	2966-140-ST-FW	SHRKTH ASSY,RH,3"D-BOLT FLT WL
13	1	2966-141	SPOKE WHEEL ASSY, LH, 3" D-BOLT
	1	2966-141-BW	BEVEL WHEEL ASSY, LH, 3" D-BOLT
	1	2966-141-BW-FW	BEVEL WHEEL ASSY, RH, 3" D-BOLT FLT WHL
	1	2966-141-FW	SPOKE WHEEL ASSY, RH, 3" D-BOLT FLT WHL
	1	2966-141-HD	HD SPOKE WHEEL ASSY, RH, 3" D-BOLT
	1	2966-141-HD-FW	HD FW SPOKE WHEEL ASSY, RH, 3" D-BOLT
	1	2966-141-ST	SHARKTOOH ASSY, RH, 3" D-BOLT
	1	2966-141-ST-FW	SHRKTH ASSY,RH,3"D-BOLT FLT WL
14	2	2967-392	SHIELD, RM COMBO-PAINTED

**MANUFACTURED 02/2013-09/2013**

# PARTS IDENTIFICATION

2940-002-ST-FW

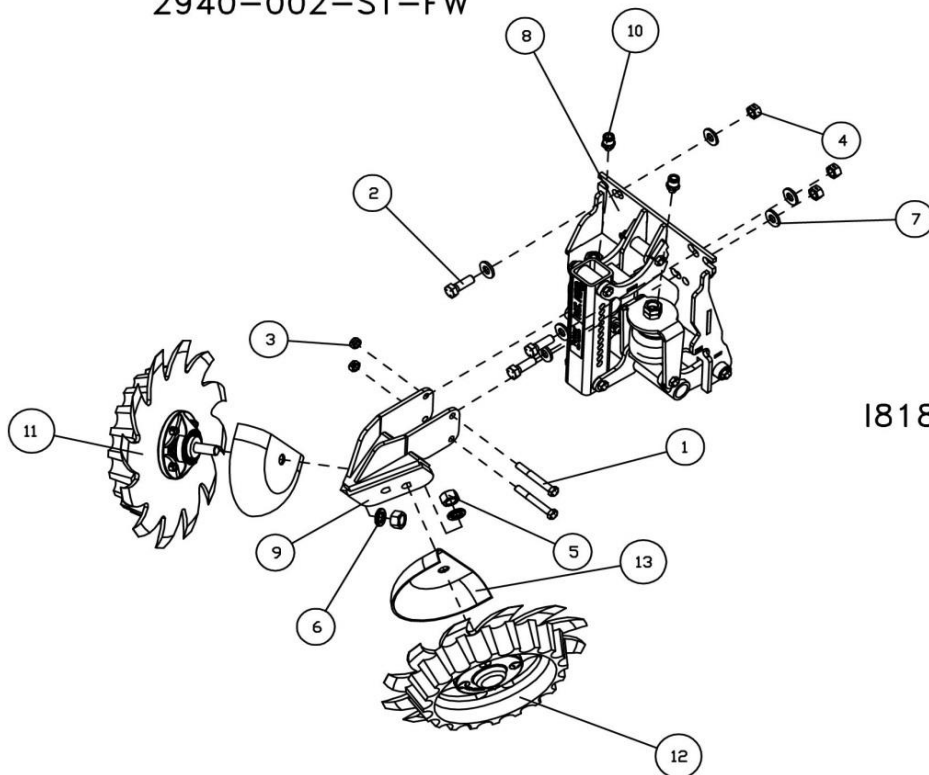

1818-2

ITEM	QTY	PART NO.	DESCRIPTION
1	2	2502-246	3/8-16 X 3 HHCS GR5 ZP
2	3	2502-294	1/2-13 X 1-1/2 HHCS GR5 YD
3	2	2520-255	3/8-16 LOCK HEX NUT ZP
4	3	2520-357	1/2-13 LOCK HEX NUT ZP
5	2	2520-452	5/8-11 HEXNUT ZP
6	2	2525-451	5/8 MED LOCKWASHER ZP
7	6	2526-355	1/2 FLAT WASHER HARD'ND ZYD
8	1	2940-190	PNEUMATIC R.M. MOUNT ASSEMBLY
9	1	2940-216	AIR ADJUST NARROW STEM W.A.
10	2	2940-339	3/8 PUSH CONNECT STRAIGHT 1/8 NPT MALE THREAD
11	1	2966-140	SPOKE WHEEL ASSY, RH, 3' D-BOLT
		2966-140-BW	BEVEL WHEEL ASSY, RH, 3' D-BOLT
		2966-140-BW-FW	BEVEL WHEEL ASSY, RH, 3' D-BOLT FLT WHL
		2966-140-FW	SPOKE WHEEL ASSY, RH, 3' D-BOLT FLT WHL
		2966-140-HD	HD SPOKE WHEEL ASSY, RH, 3' D-BOLT
		2966-140-HD-FW	HD FW SPOKE WHEEL ASSY, RH, 3' D-BOLT
		2966-140-ST	SHARKTOOH ASSY, RH, 3' D-BOLT
		2966-140-ST-FW	SHRKTH ASSY,RH,3'D-BOLT FLT WL
12	1	2966-141	SPOKE WHEEL ASSY, LH, 3' D-BOLT
		2966-141-BW	BEVEL WHEEL ASSY, LH, 3' D-BOLT
		2966-141-BW-FW	BEVEL WHEEL ASSY, LH, 3' D-BOLT FLT WHL
		2966-141-FW	SPOKE WHEEL ASSY, LH, 3' D-BOLT FLT WHL
		2966-141-HD	HD SPOKE WHEEL ASSY, LH, 3' D-BOLT
		2966-141-HD-FW	HD FW SPOKE WHEEL ASSY, LH, 3' D-BOLT
		2966-141-ST	SHARKTOOH ASSY, LH, 3' D-BOLT
		2966-141-ST-FW	SHRKTH ASSY,LH,3'D-BOLT FLT WL
13	2	2967-392	SHIELD, RM COMBO-PAINTED

**MANUFACTURED 10/2013-PRESENT**

# PARTS IDENTIFICATION

2940-002-ST-FW

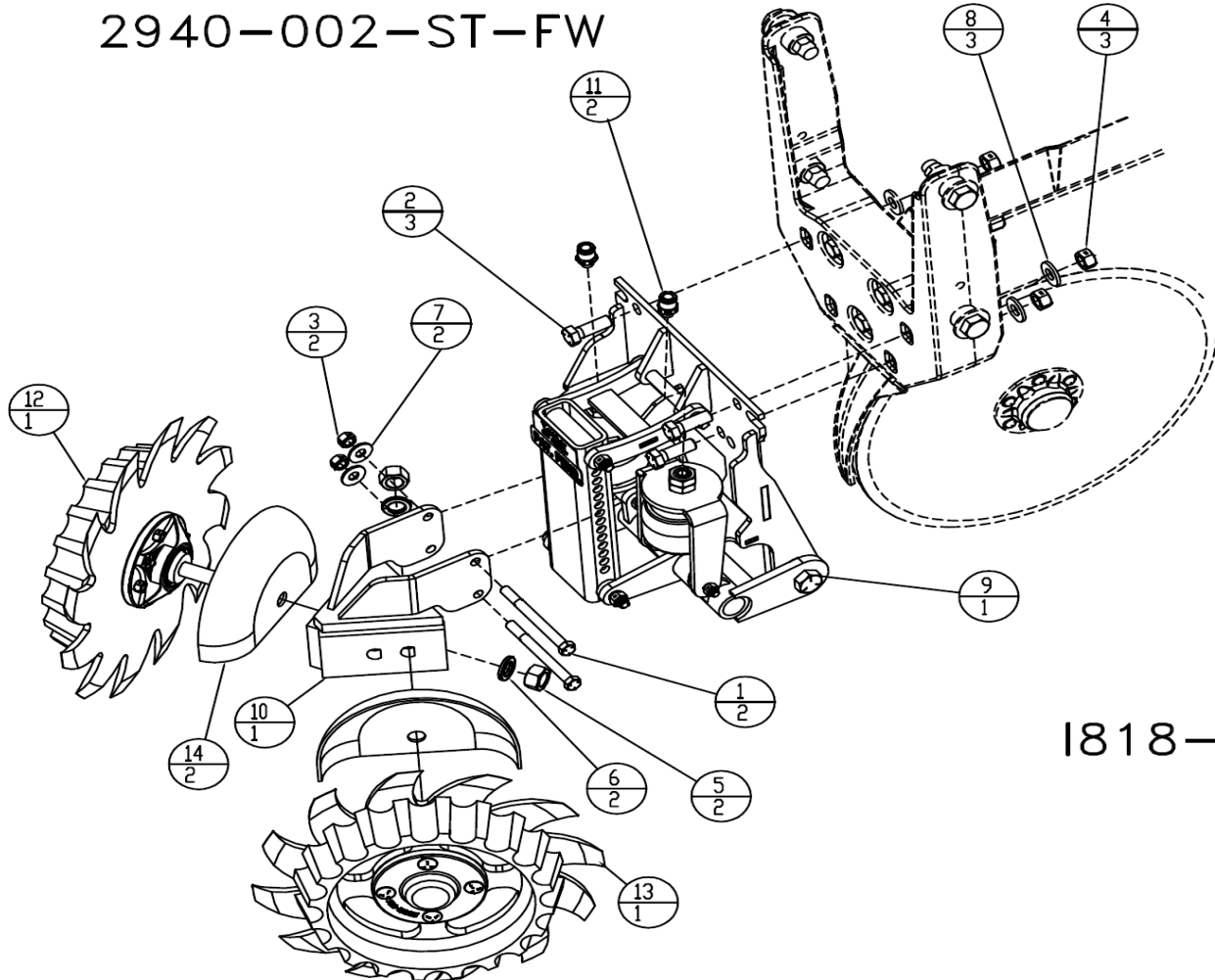

1818-2

ITEM	QTY	PART NO.	DESCRIPTION
1	2	2502-259	3/8-16 x 4-1/4 HHCS GR 5 ZP.
2	3	2502-294	1/2-13 X 1-1/2 HHCS GR5 ZP
3	2	2520-255	3/8-16 LOCK HEX NUT ZP.
4	3	2520-357	1/2-13 LOCK HEX NUT ZP
5	2	2520-452	5/8-11 HEXNUT ZP
6	2	2525-451	5/8 MED. LOCKWASHER ZP.
7	2	2526-251	3/8 STANDARD FLATWASHER ZP
8	3	2526-355	1/2 FLAT WASHER HARD'ND ZP
9	1	2940-140	PNEUMATIC R.M. MOUNT ASSEMBLY
10	1	2940-201	AIR ASSIST STEM W.A., NARROW
11	2	2940-339	3/8 PUSH CONNECT STRAIGHT 1/8 NPT MALE THREAD
12	1	2966-140	SPOKE WHEEL ASSY, RH, 3" D-BOLT
	1	2966-140-BW	BEVEL WHEEL ASSY, RH, 3" D-BOLT
	1	2966-140-BW-FW	BEVEL WHEEL ASSY, RH, 3" D-BOLT FLT WHL
	1	2966-140-FW	SPOKE WHEEL ASSY, RH, 3" D-BOLT FLT WHL
	1	2966-140-HD	HD SPOKE WHEEL ASSY, RH, 3" D-BOLT
	1	2966-140-HD-FW	HD FW SPOKE WHEEL ASSY, RH, 3" D-BOLT
	1	2966-140-ST	SHARKTOOH ASSY, RH, 3" D-BOLT
	1	2966-140-ST-FW	SHRKTH ASSY,RH,3"D-BOLT FLT WL
13	1	2966-141	SPOKE WHEEL ASSY, LH, 3" D-BOLT
	1	2966-141-BW	BEVEL WHEEL ASSY, LH, 3" D-BOLT
	1	2966-141-BW-FW	BEVEL WHEEL ASSY, RH, 3" D-BOLT FLT WHL
	1	2966-141-FW	SPOKE WHEEL ASSY, RH, 3" D-BOLT FLT WHL
	1	2966-141-HD	HD SPOKE WHEEL ASSY, RH, 3" D-BOLT
	1	2966-141-HD-FW	HD FW SPOKE WHEEL ASSY, RH, 3" D-BOLT
	1	2966-141-ST	SHARKTOOH ASSY, RH, 3" D-BOLT
	1	2966-141-ST-FW	SHRKTH ASSY,RH,3"D-BOLT FLT WL
14	2	2967-392	SHIELD, RM COMBO-PAINTED

**MANUFACTURED 02/2013-09/2013**

# PARTS IDENTIFICATION

**2940-003-ST-FW**

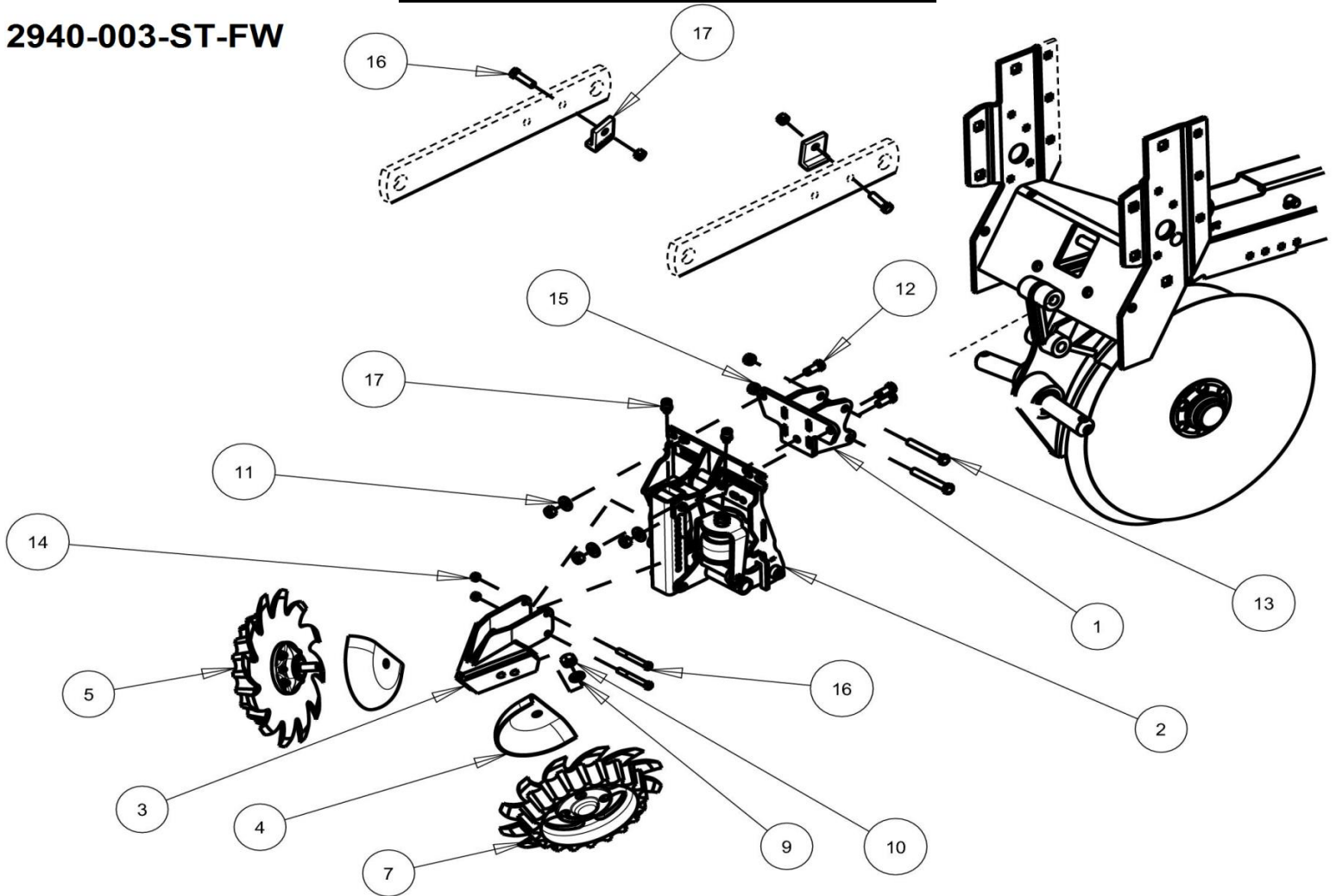

ITEM	PART #	DESCRIPTION	QTY
1	2940-209	MOUNT ADAPTER W.A., CNH	1
2	2940-190	PNEUMATIC R.M. MOUNT ASSEMBLY	1
3	2940-215	AIR ADJUST WIDE STEM W.A.	1
4	2967-392	SHIELD, RM COMBO-PAINTED	2
5	2966-140-ST-FW	SHRKTW WHEEL ASSY., RH, FW, 3"D-BOLT	1
-	2967-602	13" SHARK TOOTH WHEEL	1
-	2965-128	HUB & BEARING ASSY., 4 BOLT	1
-	2967-555	FLOATER WHEEL	1
-	2570-740	D-BOLT, FLGD, 5/8-11 X 2.812 GR. 8	1
-	2965-352	HUB CAP CASTING, 4 BOLT, BLACK	1
-	2505-209	5/16-18 X 1 3/4 CRBLT G5 YD	4
6	N10213	5/16-18 SERRATED FLNG NTZP	4
7	2966-141-ST-FW	SHRKTW WHEEL ASSY., LH, FW, 3" D-BOLT	1
-	2967-602	13" SHARK TOOTH WHEEL	1
-	2965-128	HUB & BEARING ASSY., 4 BOLT	1
-	2967-555	FLOATER WHEEL	1
-	2570-740	D-BOLT, FLGD, 5/8-11 X 2.812 GR. 8	1
-	2965-352	HUB CAP CASTING, 4 BOLT, BLACK	1
-	2505-209	5/16-18 X 1 3/4 CRBLT G5 YD	4
8	N10213	5/16-18 SERRATED FLNG NTZP	4
9	2525-451	5/8 MED. LOCKWASHER ZP.	2
10	2520-452	5/8-11 HEXNUT ZP	2
11	2526-355	1/2 FLAT WASHER HARD'ND ZYD	3
12	2502-293	1/2-13 X 1-1/4 HHCS GR5 YD	3
13	2502-316	1/2-13 X 3-1/2 HHCS GR5 ZP	2
14	2520-255	3/8-16 LOCK HEX NUT ZP	4
15	2520-357	1/2-13 LOCK HEX NUT ZP	5
16	2502-246	3/8-16 X 3 HHCS GR5 ZP	2
17	2940-339	3/8 PUSH CONNECT STRAIGHT 1/8 NPT MALE THREAD	2
16	2502-244	3/8-16 X 1-1/4 HHCS GR 5 ZP	2
17	2960-223	CYCLO STOP CASTING	2

**MANUFACTURED 10/2013-PRESENT**

# PARTS IDENTIFICATION

2940-003-ST-FW

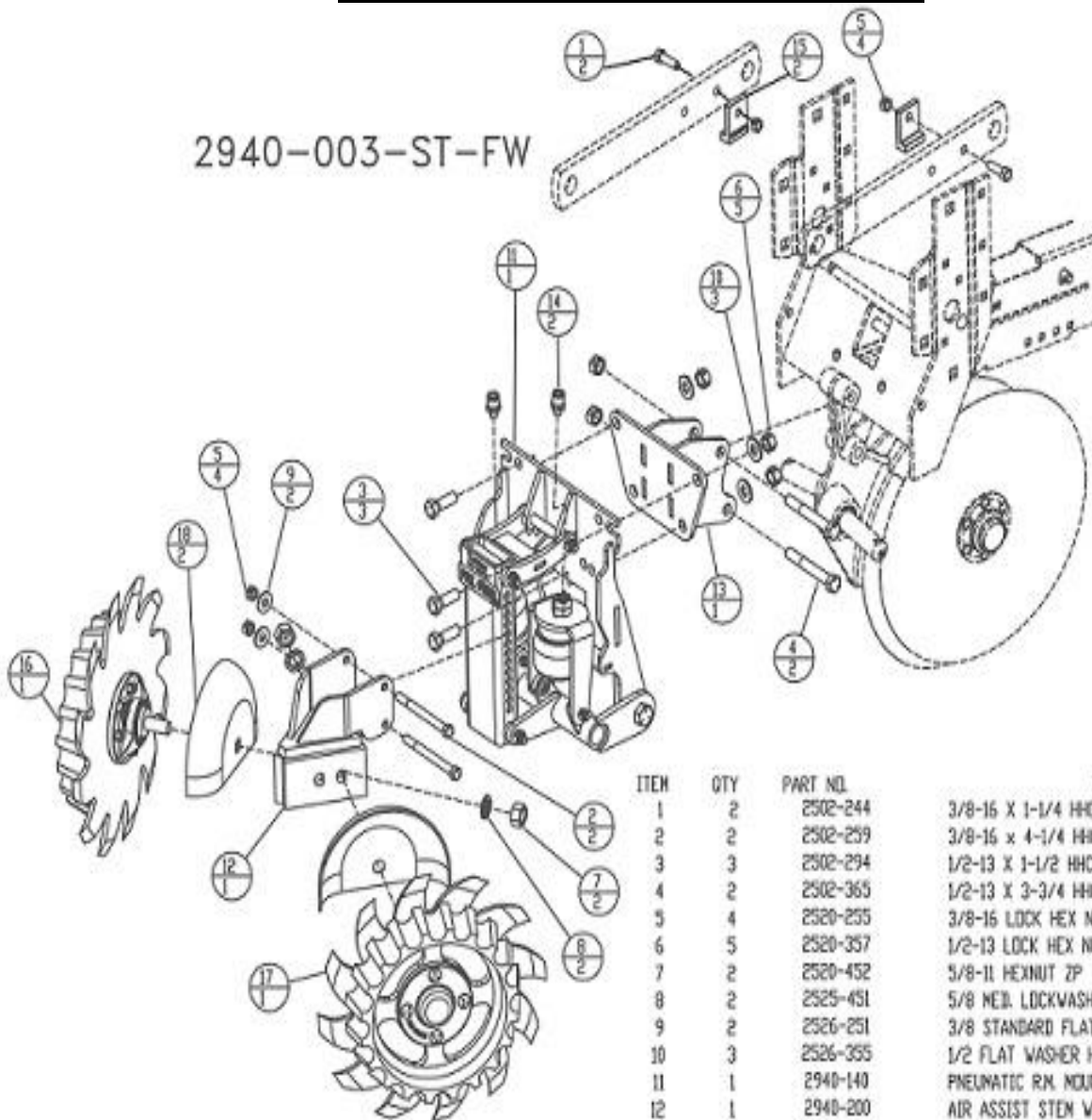

1818-3

ITEM	QTY	PART NO.	DESCRIPTION
1	2	2502-244	3/8-16 X 1-1/4 HCS GR 5 ZP
2	2	2502-259	3/8-16 x 4-1/4 HCS GR 5 ZP.
3	3	2502-294	1/2-13 X 1-1/2 HCS GR5 YD
4	2	2502-365	1/2-13 X 3-3/4 HCS GR5 YD
5	4	2520-255	3/8-16 LOCK HEX NUT ZP
6	5	2520-357	1/2-13 LOCK HEX NUT ZP
7	2	2520-452	5/8-11 HEXNUT ZP
8	2	2525-451	5/8 MED. LOCKWASHER ZP.
9	2	2526-251	3/8 STANDARD FLATWASHER ZP
10	3	2526-355	1/2 FLAT WASHER HARDND ZYD
11	1	2940-140	PNEUMATIC RM. MOUNT ASSEMBLY
12	1	2940-200	AIR ASSIST STEM W.A.
13	1	2940-209	MDUNT ADAPTER W.A. CNH
14	2	2940-339	3/8 PUSH CONNECT STRAIGHT 1/8 NPT MALE THREAD
15	2	2960-223	CYCLD STOP CASTING
16	1	2966-140	SPOKE WHEEL ASSY, RH, 3" D-BOLT
	1	2966-140-BV	BEVEL WHEEL ASSY, RH, 3" D-BOLT
	1	2966-140-BV-FW	BEVEL WHEEL ASSY, RH, 3" D-BOLT FLT WHL.
	1	2966-140-FV	SPOKE WHEEL ASSY, RH, 3" D-BOLT FLT WHL.
	1	2966-140-HD	HD SPOKE WHEEL ASSY, RH, 3" D-BOLT
	1	2966-140-HD-FW	HD FV SPOKE WHEEL ASSY, RH, 3" D-BOLT
	1	2966-140-ST	SHARKTOOTH ASSY, RH, 3" D-BOLT
	1	2966-140-ST-FW	SHRPTH ASSY,RH,3"D-BOLT FLT WL
17	1	2966-141	SPOKE WHEEL ASSY, LH, 3" D-BOLT
	1	2966-141-BV	BEVEL WHEEL ASSY, LH, 3" D-BOLT
	1	2966-141-BV-FW	BEVEL WHEEL ASSY, RH, 3" D-BOLT FLT WHL.
	1	2966-141-FV	SPOKE WHEEL ASSY, RH, 3" D-BOLT FLT WHL.
	1	2966-141-HD	HD SPOKE WHEEL ASSY, RH, 3" D-BOLT
	1	2966-141-HD-FV	HD FV SPOKE WHEEL ASSY, RH, 3" D-BOLT
	1	2966-141-ST	SHARKTOOTH ASSY, RH, 3" D-BOLT
	1	2966-141-ST-FW	SHRPTH ASSY,RH,3"D-BOLT FLT WL
18	2	2967-392	SHIELD, RM COMBO-PAINTED

**MANUFACTURED 02/2013-09/2013**

# PARTS IDENTIFICATION

2940-004-ST-FW

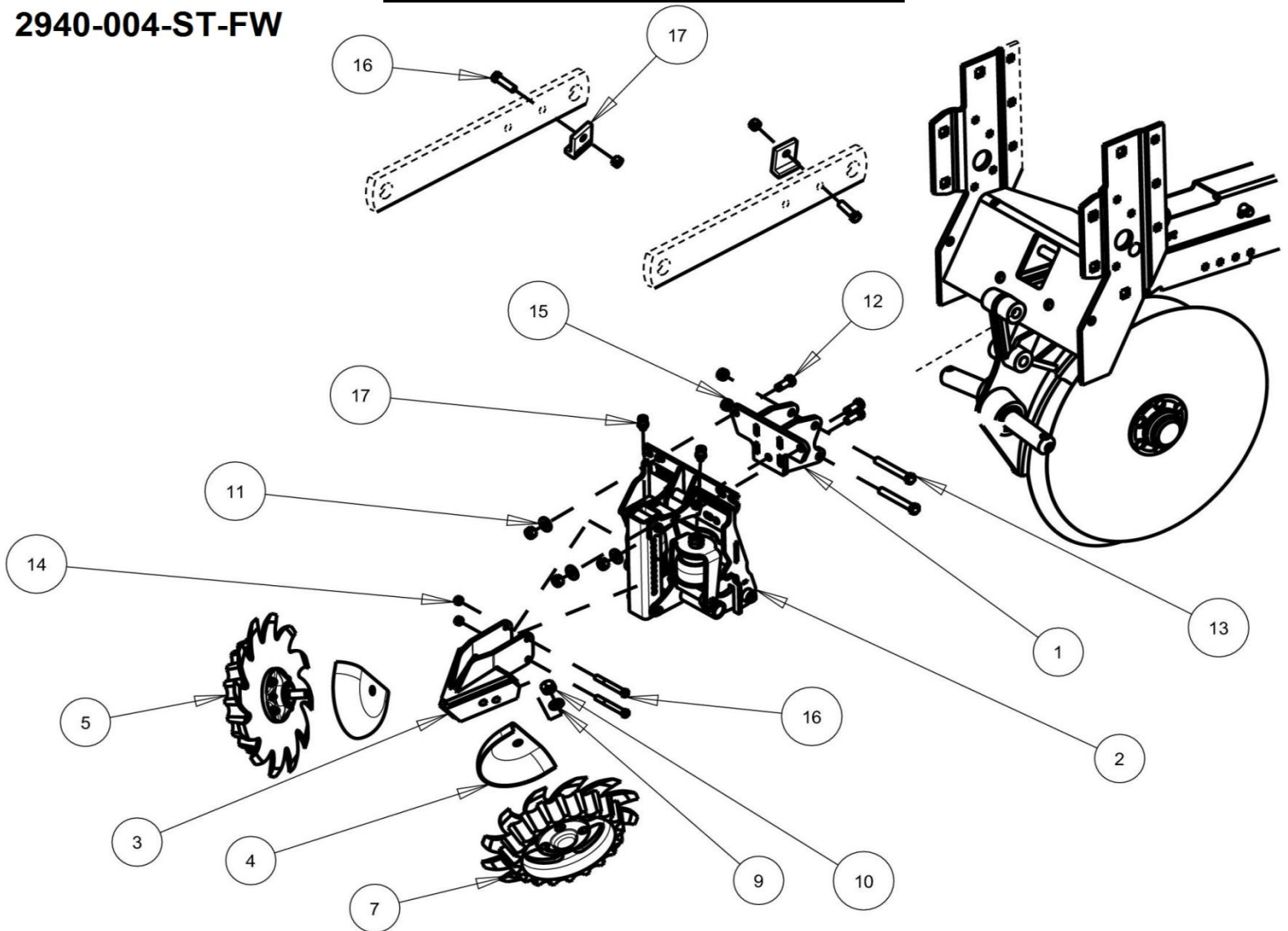

ITEM	PART #	DESCRIPTION	QTY
1	2940-209	MOUNT ADAPTER W.A., CNH	1
2	2940-190	PNEUMATIC R.M. MOUNT ASSEMBLY	1
3	2940-216	AIR ADJUST NARROW STEM W.A.	1
4	2967-392	SHIELD, RM COMBO-PAINTED	2
5	2966-140-ST-FW	SHRKTW WHEEL ASSY, RH, FW, 3"D-BOLT	1
-	2967-602	13" SHARK TOOTH WHEEL	1
-	2965-128	HUB & BEARING ASSY., 4 BOLT	1
-	2967-555	FLOATER WHEEL	1
-	2570-740	D-BOLT, FLGD, 5/8-11 X 2.812 GR. 8	1
-	2965-352	HUB CAP CASTING, 4 BOLT, BLACK	1
-	2505-209	5/16-18 X 1 3/4 CRBLT G5 YD	4
6	N10213	5/16-18 SERRATED FLNG NTZP	4
7	2966-141-ST-FW	SHRKTW WHEEL ASSY, LH, FW, 3" D-BOLT	1
-	2967-602	13" SHARK TOOTH WHEEL	1
-	2965-128	HUB & BEARING ASSY., 4 BOLT	1
-	2967-555	FLOATER WHEEL	1
-	2570-740	D-BOLT, FLGD, 5/8-11 X 2.812 GR. 8	1
-	2965-352	HUB CAP CASTING, 4 BOLT, BLACK	1
-	2505-209	5/16-18 X 1 3/4 CRBLT G5 YD	4
8	N10213	5/16-18 SERRATED FLNG NTZP	4
9	2525-451	5/8 MED. LOCKWASHER ZP.	2
10	2520-452	5/8-11 HEXNUT ZP	2
11	2526-355	1/2 FLAT WASHER HARD'ND ZYD	3
12	2502-293	1/2-13 X 1-1/4 HHCS GR5 YD	3
13	2502-316	1/2-13 X 3-1/2 HHCS GR5 ZP	2
14	2520-255	3/8-16 LOCK HEX NUT ZP	4

**MANUFACTURED 10/2013-PRESENT**



# PARTS IDENTIFICATION

2940-004-ST-FW

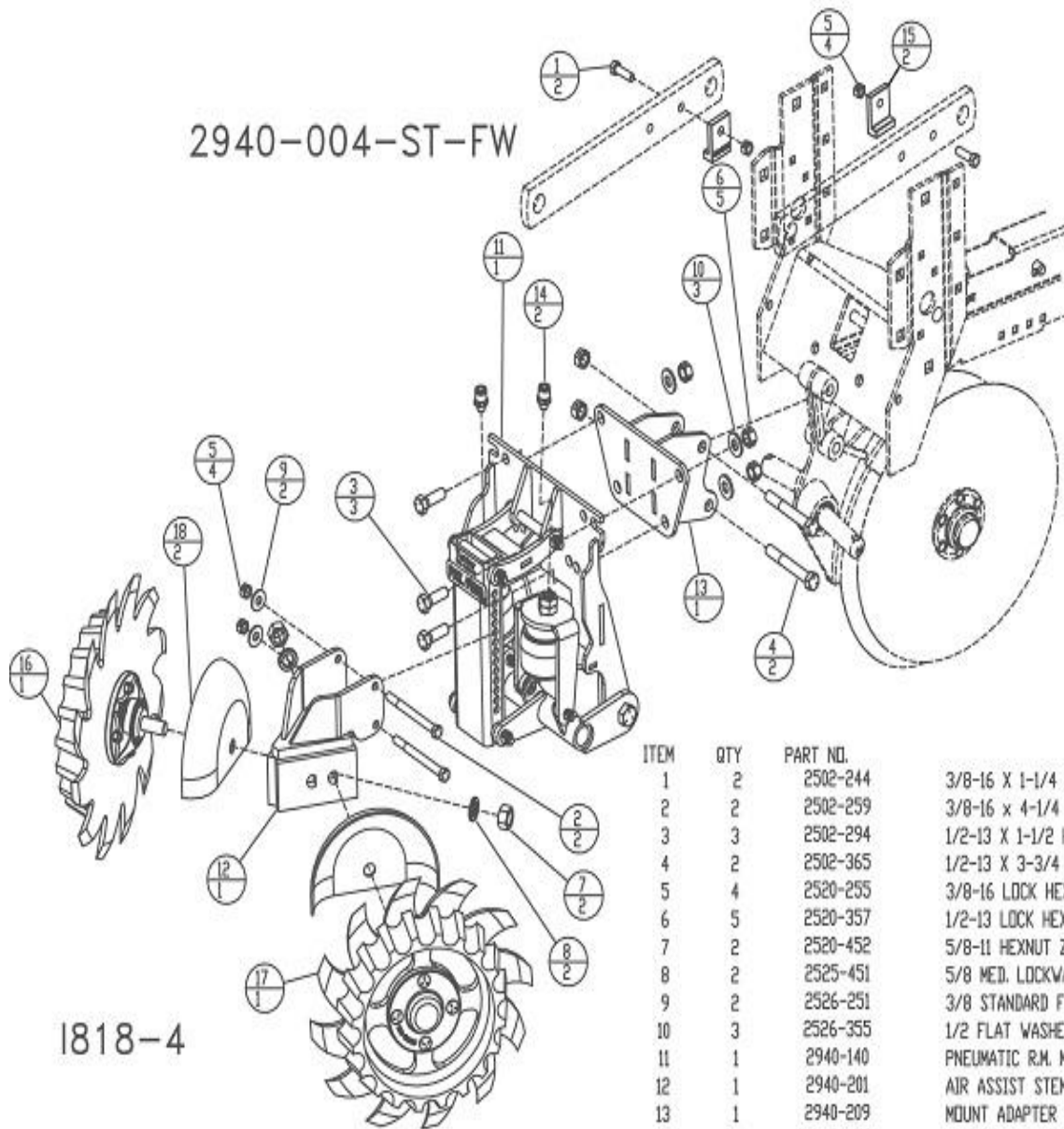

1818-4

ITEM	QTY	PART NO.	DESCRIPTION
1	2	2502-244	3/8-16 X 1-1/4 HHCS GR 5 ZP
2	2	2502-259	3/8-16 x 4-1/4 HHCS GR 5 ZP.
3	3	2502-294	1/2-13 X 1-1/2 HHCS GR5 YD
4	2	2502-365	1/2-13 X 3-3/4 HHCS GR5 YD
5	4	2520-255	3/8-16 LOCK HEX NUT ZP
6	5	2520-357	1/2-13 LOCK HEX NUT ZP
7	2	2520-452	5/8-11 HEXNUT ZP
8	2	2525-451	5/8 MED. LOCKWASHER ZP.
9	2	2526-251	3/8 STANDARD FLATWASHER ZP
10	3	2526-355	1/2 FLAT WASHER HARD'ND ZYD
11	1	2940-140	PNEUMATIC R.M. MOUNT ASSEMBLY
12	1	2940-201	AIR ASSIST STEM W.A., NARROW
13	1	2940-209	MOUNT ADAPTER W.A., CNH
14	2	2940-339	3/8 PUSH CONNECT STRAIGHT 1/8 NPT MALE THREAD
15	2	2960-223	CYCLO STOP CASTING
16	1	2966-140	SPOKE WHEEL ASSY, RH, 3" D-BOLT
	1	2966-140-BW	BEVEL WHEEL ASSY, RH, 3" D-BOLT
	1	2966-140-BW-FW	BEVEL WHEEL ASSY, RH, 3" D-BOLT FLT WHL
	1	2966-140-FW	SPOKE WHEEL ASSY, RH, 3" D-BOLT FLT WHL
	1	2966-140-HD	HD SPOKE WHEEL ASSY, RH, 3" D-BOLT
	1	2966-140-HD-FW	HD FW SPOKE WHEEL ASSY, RH, 3" D-BOLT
	1	2966-140-ST	SHARKTOOTH ASSY, RH, 3" D-BOLT
	1	2966-140-ST-FW	SHRKT ASSY,RH,3"D-BOLT FLT WL
17	1	2966-141	SPOKE WHEEL ASSY, LH, 3" D-BOLT
	1	2966-141-BW	BEVEL WHEEL ASSY, LH, 3" D-BOLT
	1	2966-141-BW-FW	BEVEL WHEEL ASSY, RH, 3" D-BOLT FLT WHL
	1	2966-141-FW	SPOKE WHEEL ASSY, RH, 3" D-BOLT FLT WHL
	1	2966-141-HD	HD SPOKE WHEEL ASSY, RH, 3" D-BOLT
	1	2966-141-HD-FW	HD FW SPOKE WHEEL ASSY, RH, 3" D-BOLT
	1	2966-141-ST	SHARKTOOTH ASSY, RH, 3" D-BOLT
	1	2966-141-ST-FW	SHRKT ASSY,RH,3"D-BOLT FLT WL
18	2	2967-392	SHIELD, RM COMBO-PAINTED

**MANUFACTURED 02/2013-09/2013**

# PARTS IDENTIFICATION

## 2940-190

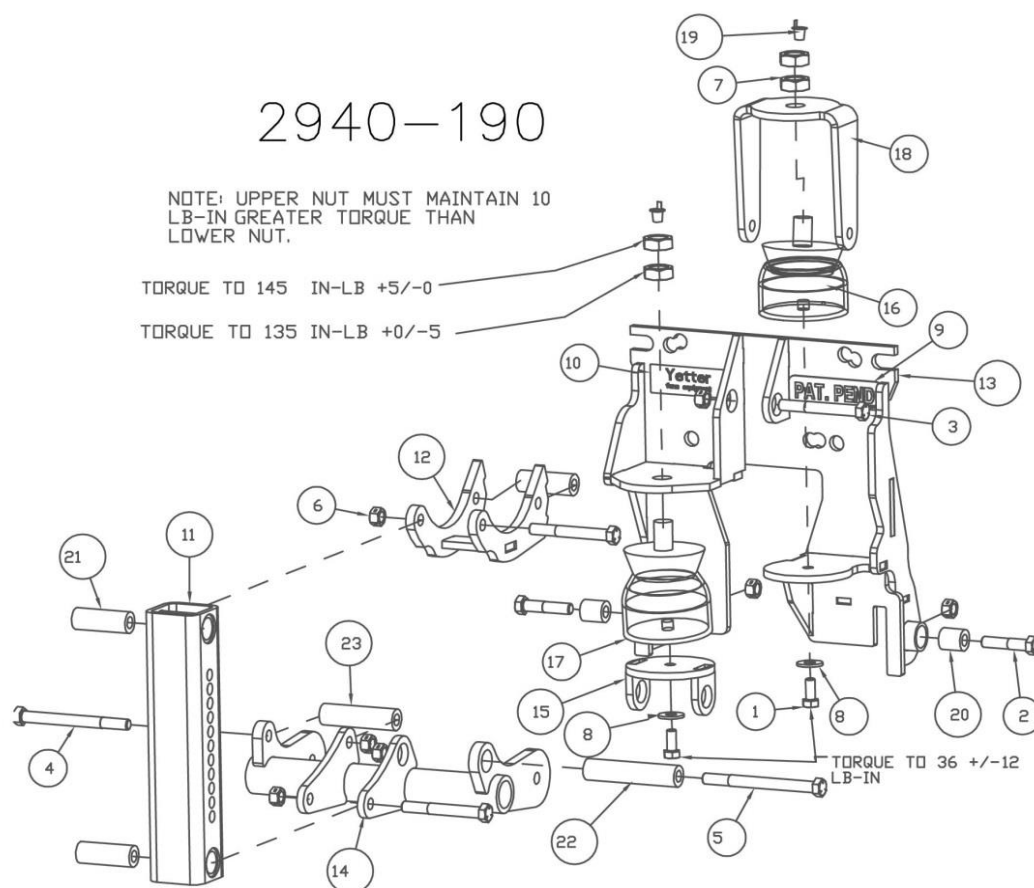

ITEM	PART NO.	DESCRIPTION	QTY
1	2502-200	5/16-18 X 3/4 HHCS W/THD LCK GR 2 ZP	2
2	2502-245	3/8-16 X 1-3/4 HHCS GR 5 ZP	2
3	2502-246	3/8-16 X 3 HHCS GR5 ZP	3
4	2502-254	3/8-16 X 4 HHCS GR 5 ZP	1
5	2502-260	3/8-16 x 4-1/2 HHCS GR 5 ZP.	1
6	2520-255	3/8-16 LOCK HEX NUT ZP	7
7	2520-454	5/8-11 BRASS JAM NUT	4
8	2526-201	5/16STANDARD FLATWASHER ZP	2
9	2565-071	PATENT PENDING DECAL	1
10	2565-179	YETTER DECAL, 1 X 3	1
11	2940-210	ADJUSTMENT TUBE W.A.	1
12	2940-211	UPPER LINK W.A.	1
13	2940-212	UNIVERSAL MOUNT PLATE W.A.	1
14	2940-213	LOWER PARALLEL ARM W.A.	1
15	2940-214	AIR BAG BRACKET W.A.	1
16	2940-306	FPE SK-37-6 INCH AIR BAG	1
17	2940-308	FPE SK-37-8 INCH AIR BAG	1
18	2940-309	UPFORCE TOP MOUNT	1
19	2940-340	CAP PLUG - 171201HB L-2 PE-LD01R	2
20	2940-472	.750" OD X .406" ID X .810" BUSHING	2
21	2940-473	.750" OD X .406" ID X 2" BUSHING	3
22	2940-474	.750"OD X .406" ID X 3.437" BUSHING	1
23	2940-475	.750" OD X .406" ID X 2.756" BUSHING	1

**MANUFACTURED 10/2013-PRESENT**

# PARTS IDENTIFICATION

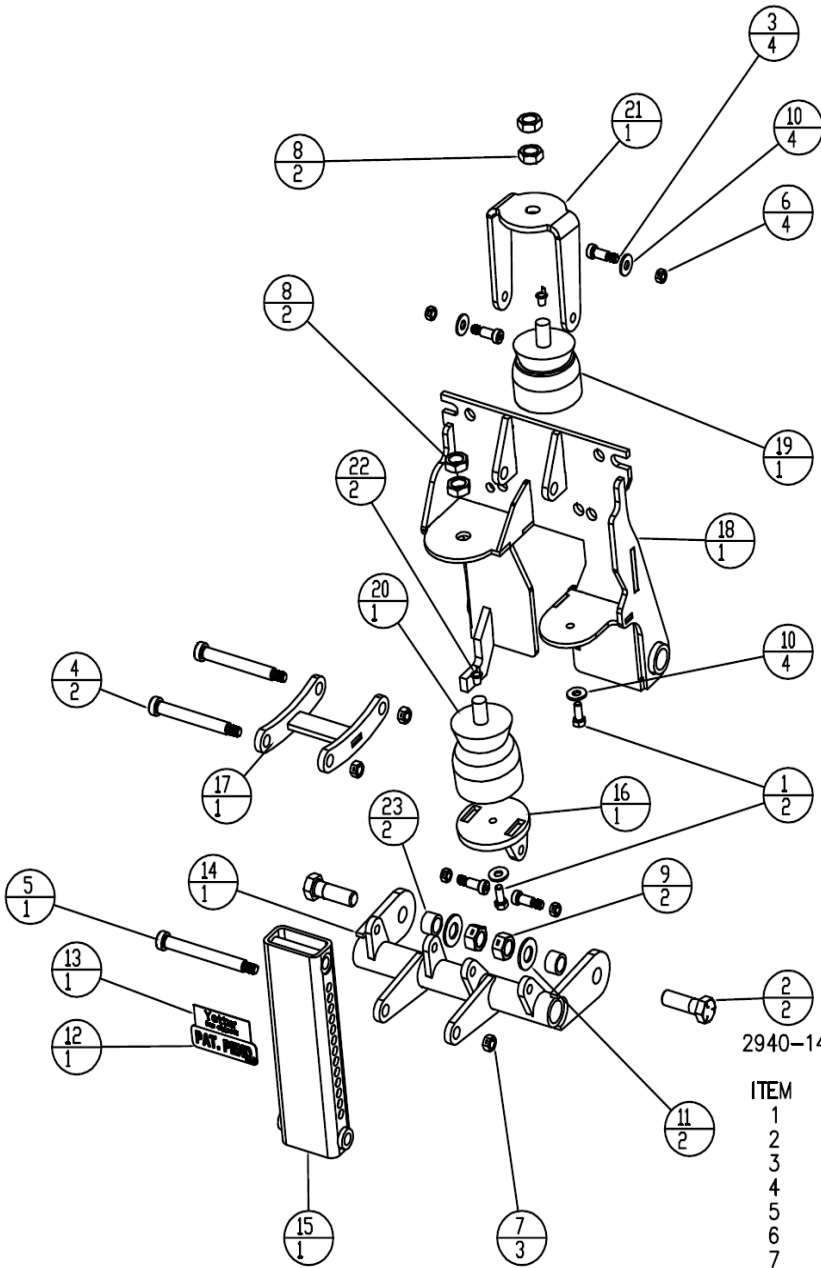

1818-8

2940-140 RESIDUE MANAGER AIR BAG/MOUNT BRACKET ASSEMBLY

ITEM	QTY	PART NO.	DESCRIPTION
1	2	2502-200	5/16-18 X 3/4 HHCS GR 2 ZP
2	2	2502-391	5/8-11 X 2 HHCS GR 5 ZP
3	4	2510-310	3/8 X 3/4 SHOULDER BOLT ALLOY
4	2	2510-320	1/2 X 3-3/4 SHOULDER BOLT ALLOY
5	1	2510-321	1/2 X 4-1/4 SHOULDER BOLT ALLOY
6	4	2520-205	5/16-18 LOCK HEX NUT ZP
7	3	2520-255	3/8-16 LOCK HEX NUT ZP
8	4	2520-454	5/8-11 BRASS JAM NUT
9	2	2520-459	5/8-11 LOCK HEX NUT ZP
10	4	2526-201	5/16STANDARD FLATWASHER ZP
11	2	2526-453	5/8 SAE FLATWASHER ZP
12	1	2565-071	PATENT PENDING DECAL
13	1	2565-179	YETTER DECAL, 1 X 3
14	1	2940-202	SHORT LOWER RACK W.A.
15	1	2940-203	STEM TUE W.A.
16	1	2940-204	AIR BAG LOWER W.A.
17	1	2940-205	UPPER LINK W.A.
18	1	2940-206	UNIVERSAL MOUNT PLATE W.A.
19	1	2940-306	FPE SK-37-6" SMALLER AIR BAG
20	1	2940-308	FPE SK-37-8 INCH LARGER AIR BAG
21	1	2940-309	UPFORCE TOP MOUNT
22	2	2940-340	CAP PLUG - 171201HB L-2 PE-LD01R
23	2	6000-335	9/16" BUSHING

**MANUFACTURED 02/2013-09/2013**

# PARTS IDENTIFICATION

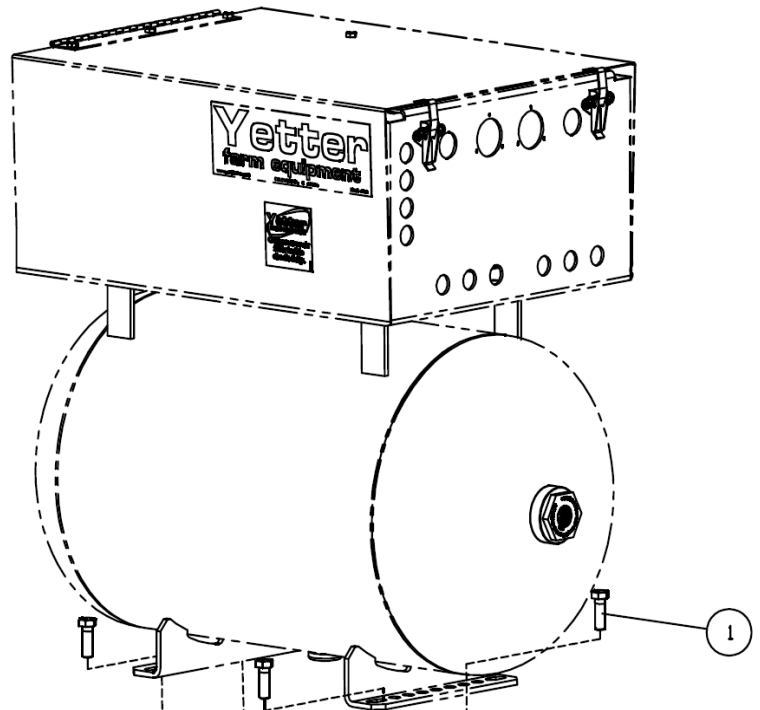

1818-9

## 2940-085 TWO POINT OR UNIVERSAL COMPRESSOR MOUNT KIT

ITEM	QTY	PART NO.	DESCRIPTION
1	4	2502-294	1/2-13 X 1-1/2 HHCS GR 5 ZP.
2	4	2525-352	1/2 MED LOCKWASHER ZP
3	4	2520-352	1/2-13 HEX NUT ZP.
4	1	2940-207	COMPRESSOR MOUNT W.A., L.H.
5	1	2940-208	COMPRESSOR MOUNT W.A., R.H.
6	4	2502-368	1/2-13 X 5-1/2 HHCS GR 5 ZP.
7	4	2526-351	1/2 STANDARD FLATWASHER ZP.
8	4	2520-357	1/2-13 LOCK HEX NUT ZP
9	4	2940-355	MOUNT STRAP

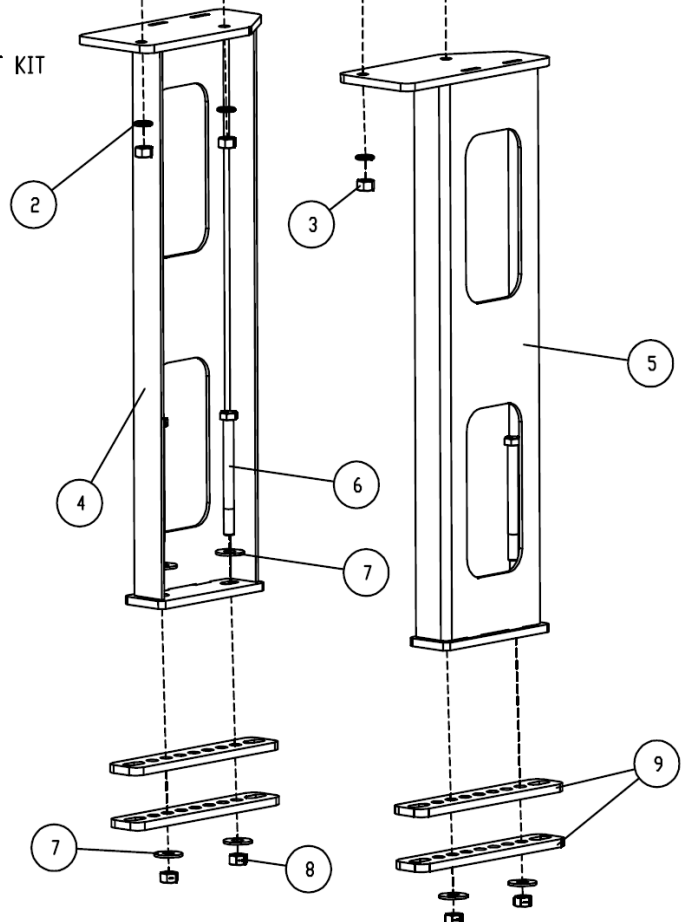

# PARTS IDENTIFICATION

1818-10

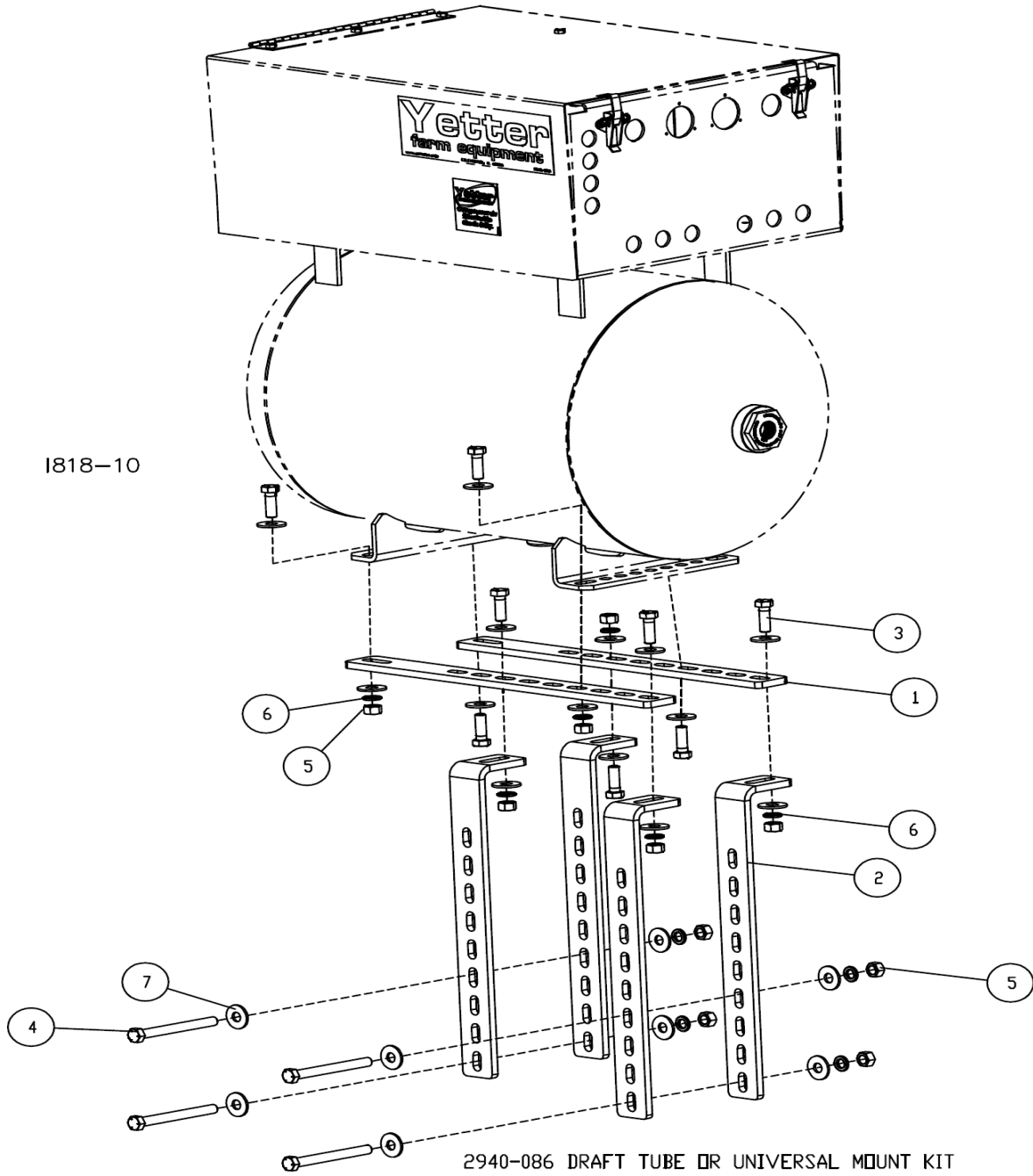

2940-086 DRAFT TUBE OR UNIVERSAL MOUNT KIT

ITEM	QTY	PART NO.	DESCRIPTION
1	2	2940-344	COMPRESSOR STRAP
2	4	2940-351	COMPRESSOR MOUNT BRACKET
3	8	2502-294	1/2-13 X 1-1/2 HHCS GR 5 ZP.
4	4	2502-349	1/2-13 X 5 FLTHD HHCS GR 5 ZP.
5	12	2520-352	1/2-13 HEX NUT ZP.
6	12	2525-352	1/2 MED LOCKWASHER ZP.
7	20	2526-351	1/2 STANDARD FLATWASHER ZP.

# PARTS IDENTIFICATION

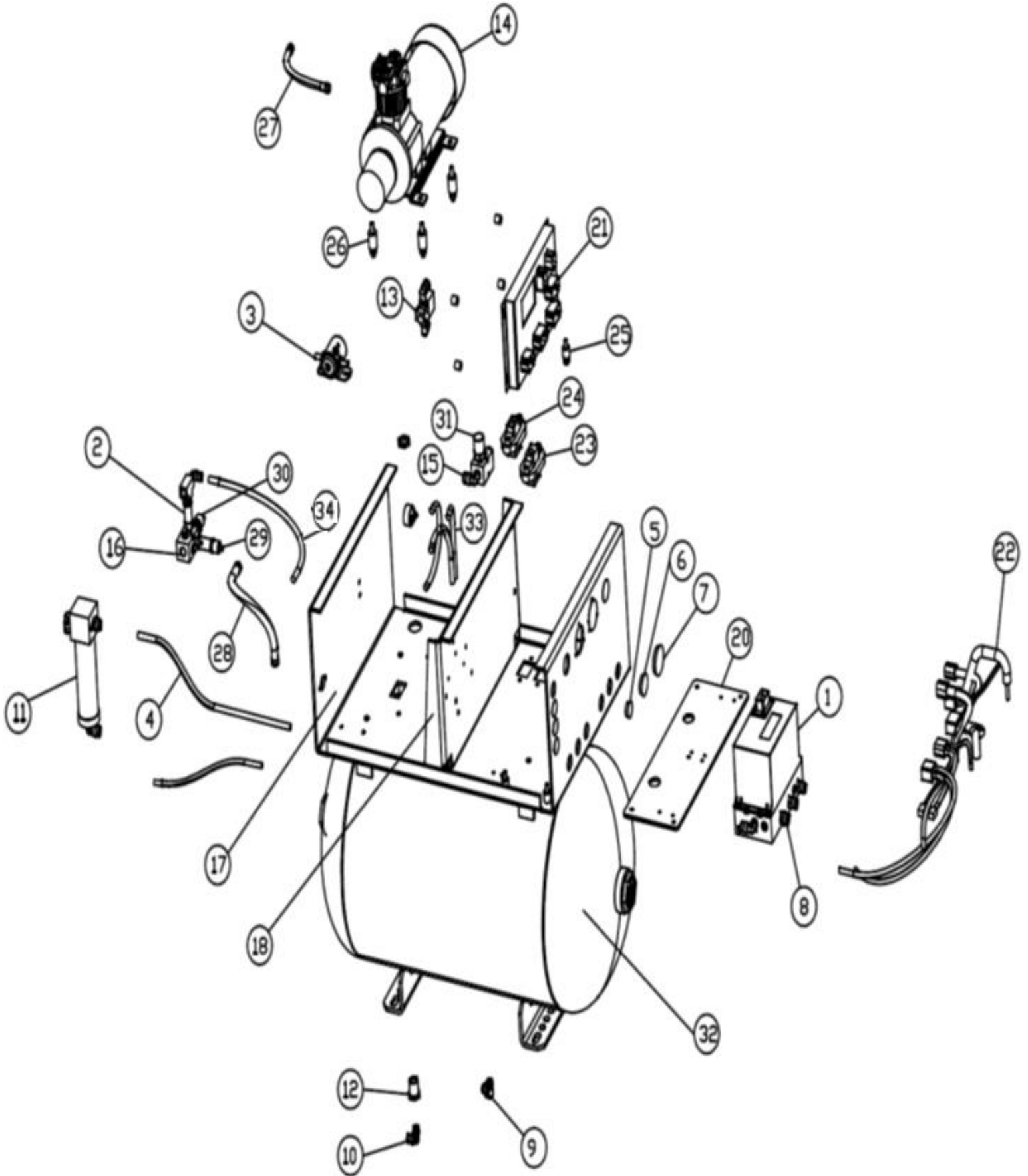

# PARTS IDENTIFICATION

#	P/N	Description	Qty
1	2940-402	PQE	1
2	2940-392	CHECK VALVE	1
3	2940-391	RELAY	1
4	3/8 TUBE	MAIN AIR 3/8 OD TUBING 2(FT)	8
5	2940-411	7/8" HOLE PLUG	7
6	2940-412	1-1/4" HOLE PLUG	2
7	2940-413	1-3/4" HOLE PLUG	2
8	2940-414	PC-3/8-STRAIGHT FITTING	4
9	2940-408	PL-3/8-ELBOW FITTING (Bag of 5)	2
10	2940-423	¼ PC-1/4 NPT 90 DEGREE ELBOW	2
11	2940-438	WATER TRAP ASSEMBLY	1
12	2940-427	¾" BULK HEAD FITTING	1
13	2940-431	DUMP VALVE ASSEMBLY	2
14	2940-390	COMPRESSOR ASSEMBLY	1
15	2940-432	VALVE FEED ASSEMBLY	1
16	2940-433	INLET ASSEMBLY	1
17	2940-332	MAIN PLATE	1
18	2940-331	MID-PLATE	1
19	2940-143	LID ASSEMBLY (NOT SHOWN)	1
20	2940-400	PQE MOUNTING PLATE	1
21	2940-112	VDM CONTROLLER	1
22	HARNESS	HARNESSING	X
23	2940-401	DEUTSCH BULKHEAD "A KEY"	1
24	2940-403	DEUTSCH BULKHEAD "B KEY"	1
25	2940-419	STAND OFF PQE MOUNTING PLATE	4
26	2940-418	ISOLATOR STAND OFF	4
27	2940-398	SS BRAIDED COMPRESSOR LINE	1
28	2940-394	MANIFOLD/TANK HIGH TEMP HOSE	1
29	2940-416	RELIEF VALVE	1
30	2940-393	COMPRESSOR PRESSURE SWITCH	1
31	2940-441	PRESSURE TANSDUCER	1
32	2940-440	RESERVOIR	1
33	1/4" TUBES	DUMP TUBES 2(FT) BLACK	8
34	2940-435	HEAD PRESSURE RELIEF LINE	1

# PARTS IDENTIFICATION

## 2940-136 Dump Valve Kit

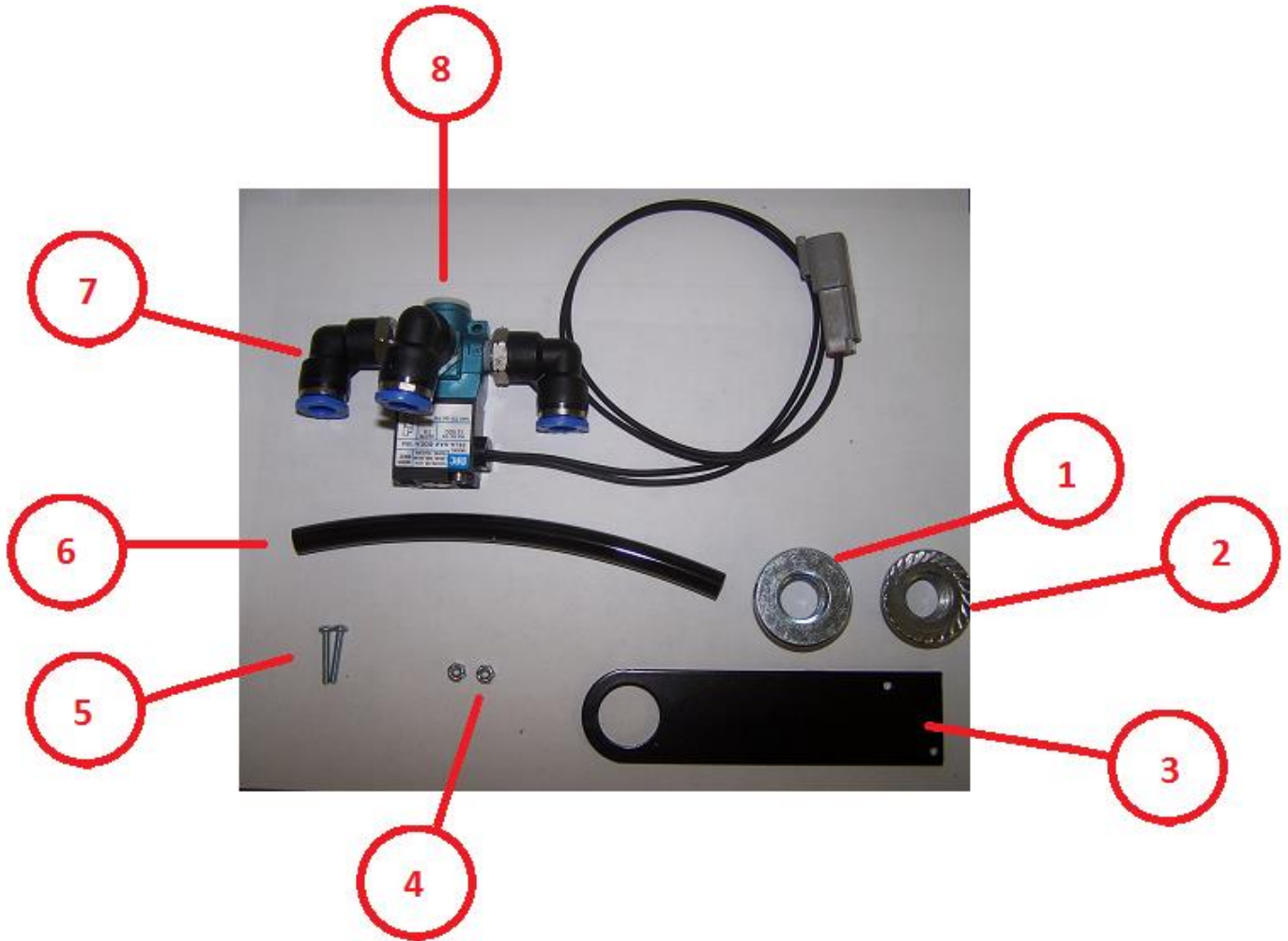

1. 14M7291 Metric Flange Hex Nut
2. 2520-464 5/8" Flange Hex Nut
3. 2940-335 Dump Valve Mount Tab
4. 2520-110 Lock Hex Nut
5. Bolt
6. 2940-138 3/8" Drain tube
7. 2940-337 3/8" Push Connect Elbow 1/8" NPT Male Thread
8. 2940-336 Dump Valve



# Troubleshooting Guide

<b>Problem</b>	<b>Cause</b>	<b>Corrective Action</b>
Tank Pressure drops when Compressor shuts off	<ol style="list-style-type: none"> <li>1. Check Valve is leaking</li> <li>2. Loose Pneumatic Connections</li> <li>3. Water Separator Drain Valve or Head Pressure Relief Valve leaking</li> </ol>	<ol style="list-style-type: none"> <li>1. Replace Check Valve</li> <li>2. Check all connections with soapy water &amp; tighten as needed</li> <li>3. replace Water Separator Drain Valve or Head Pressure Relief Valve</li> </ol>
Compressor runs continuously & air flow lower than normal	<ol style="list-style-type: none"> <li>1. Excessive air usage</li> <li>2. Loose Pneumatic Connections</li> <li>3. Worn piston or inlet valve</li> <li>4. Clogged Air Filter element</li> <li>5. Pressure Switch failure</li> <li>6. Defective Safety Valve</li> <li>7. Air leak in compressor housing</li> </ol>	<ol style="list-style-type: none"> <li>1. Decrease air usage</li> <li>2. Check all connections with soapy water &amp; tighten as needed</li> <li>3. replace Compressor</li> <li>4. replace/clean Air Filter element</li> <li>5. replace pressure switch</li> <li>6. replace Safety Valve</li> <li>7. check, Pressure On Valve, PQE, &amp; associated connections for leakage</li> </ol>
Excessive moisture in discharge	<ol style="list-style-type: none"> <li>1. Excessive water in the air tank</li> <li>2. high humidity</li> </ol>	<ol style="list-style-type: none"> <li>1. manually drain tank holding down the down arrow on the cab controller</li> <li>2. Move compressor to area humidity</li> </ol>
Compressor will not run	<ol style="list-style-type: none"> <li>1. No power or system deactivated</li> <li>2. tripped Breaker</li> <li>3. motor overheats</li> <li>4. Pressure Switch failure</li> <li>5. Solenoid failure</li> </ol>	<ol style="list-style-type: none"> <li>1. check power cables or press ENTER to activate the system</li> <li>2. reset Breaker</li> <li>3. let Compressor cool, replace if needed</li> <li>4. replace Pressure Switch</li> <li>5. replace Solenoid</li> </ol>
Excessive knocking or rattling	<ol style="list-style-type: none"> <li>1. loose mounting bolts</li> <li>2. worn Bearing</li> <li>3. Cylinder or Piston is worn</li> </ol>	<ol style="list-style-type: none"> <li>1. tighten bolts</li> <li>2. replace Compressor</li> <li>3. rebuild Compressor</li> </ol>
No air output from the RU, RD, and WT ports even though pressure is commanded and tank pressure reads 60psi or greater	<ol style="list-style-type: none"> <li>1. Air System is off</li> <li>2. no power to the VDM</li> <li>3. J3 connector on VDM plugged in upside down</li> <li>4. Improperly functioning PQE</li> <li>5. communication harness connection issue</li> </ol>	<ol style="list-style-type: none"> <li>1. press ENTER to activate system (AIR ON)</li> <li>2. check power connections from battery to VDM, check breaker on the 2940-166</li> <li>3. unplug J3 connector, check tab/slot sizes, reinstall J3 connector properly</li> <li>4. replace PQE</li> <li>5. check the end of all connectors to make sure terminal pins are all seen on the end of the male connectors and the connectors are seated tightly</li> </ol>
No ECU/VDM present displays on Cab Controller	<ol style="list-style-type: none"> <li>1. Improper communication harness connection between Cab Controller and VDM</li> </ol>	<ol style="list-style-type: none"> <li>1. start at the 6 pin connector on the back of the Cab Controller and inspect all connectors and connections to the VDM</li> </ol>

## **NOTES:**

## **NOTES:**

## **NOTES:**

# Our name Is getting known

Just a few years ago, Yetter products were sold primarily to the Midwest only. Then we embarked on a program of expansion and moved into the East, the South, the West and now north into Canada. We're even getting orders from as far away as Australia and Africa.

So, when you buy Yetter products . . .you're buying a name that's recognized. A name that's known and respected. A name that's become a part of American agriculture and has become synonymous with quality and satisfaction in the field of conservation tillage.

Thank you.

**2565-773\_REV\_D1 • 09/2024**

**YETTER MANUFACTURING CO.**  
Colchester, IL 62326-0358 • 309/776-4111  
Toll Free 800/447-5777  
Fax 309/776-3222  
Website: [WWW.YETTERCO.COM](http://WWW.YETTERCO.COM)  
E-MAIL: [INFO@YETTERCO.COM](mailto:INFO@YETTERCO.COM)