



6200-022/-023/-024

FIRMING WHEEL

**OPERATOR'S MANUAL
PART IDENTIFICATION
2565-776_REV_A - 02/2014**

YETTER MANUFACTURING CO.
FOUNDED 1930

Colchester, IL 62326-0358
Toll free: 800/447-5777
309/776-3222 (Fax)
Website: www.yetterco.com
E-mail: info@yetterco.com

YETTER

FOREWORD

You've just joined an exclusive but rapidly growing club.

For our part, we want to welcome you to the group and thank you for buying a Yetter product.

We hope your new Yetter products will help you achieve both goals-increase your productivity and increase your efficiency so that you may generate more profit.

This operator's manual has been designed into four major sections: Foreword, Safety Precautions, Installation Instructions and Parts Breakdown.



This **SAFETY ALERT SYMBOL** indicates important safety messages in the manual. When you see this symbol, be alert to the possibility of **PERSONAL INJURY** and carefully read the message that follows.

The word **NOTE** is used to convey information that is out of context with the manual text. It contains special information such as specifications, techniques and reference information of a supplementary nature.

The word **IMPORTANT** is used in the text when immediate damage will occur to the machine due

to improper technique or operation. Important will apply to the same information as specified by note only of an immediate and urgent nature.

It is the responsibility of the user to read the operator's manual and comply with the safe and correct operating procedure and to lubricate and maintain the product according to the maintenance schedule in the operator's manual.

The user is responsible for inspecting his machine and for having parts repaired or replaced when continued use of the product would cause damage or excessive wear to the other parts.

It is the user's responsibility to deliver his machine to the Yetter dealer who sold him the product for service or replacement of defective parts, which are covered by the warranty policy.

If you are unable to understand or follow the instructions provided in this publication, consult your local Yetter dealer or contact:

YETTER MANUFACTURING CO.

309/776-4111

800/447-5777

309/776-3222 (FAX)

Website: www.yetterco.com

E-mail: info@yetterco.com

WARRANTY

Yetter Manufacturing warrants all products manufactured and sold by it against defects in material. This warranty being expressly limited to replacement at the factory of such parts or products as shall appear to be defective after inspection. This warranty does not obligate the Company to bear cost of labor in replacement of parts. It is the policy of the Company to make improvements without incurring obligations to add them to any unit already sold. No warranty is made or authorized to be made, other than herein set forth. This warranty is in effect for one year after purchase.

DEALER: _____

Yetter Manufacturing warrants its own products only and cannot be responsible for damages to equipment on which mounted.

SAFETY

A brief description of signal words that may be used in this manual:

CAUTION: Used as a general reminder of good safety practices or to direct attention to unsafe practices.

WARNING: Denotes a specific potential hazard.

DANGER: Denotes the most serious specific potential hazard.

SAFETY PRECAUTIONS

You can make your farm a safer place to live and work if you observe the safety precautions given. Study these precautions carefully and insist that those working with you and for you follow them.

Finally, remember this: an accident is usually caused by someone's carelessness, neglect or oversight.



WARNING

Never clean, lubricate or adjust a machine that is in motion. Always lower or block the implement before performing service.

If the machine must be serviced in the raised position, jack or block it up to prevent it from accidentally falling and injuring someone.

Do not allow riders on the tractor or implement.

Use speeds and caution dictated by the terrain being traversed. Do not operate on any slope steep enough to cause tipping or loss of control.

Be sure all personnel are clear of the immediate area before operating.

Read and understand the operator's manual and require all other persons who will operate the equipment to do the same.

Be familiar with all tractor and implement controls and be prepared to stop engine and implements quickly in an emergency.



CAUTION

Consult your implement and tractor operator's manual for correct and safe operating practices.

Beware of towed implement width and allow safe clearance.

FAILURE TO HEED MAY RESULT IN PERSONAL INJURY OR DEATH.

BOLT TORQUE

Mounting bolts and hardware

Before operating the 6200 Packer Wheel for the first time, check to be sure that all hardware is tight. Check all hardware again after approximately 50 hours of operation and at the beginning of each planting season.

All hardware used is Grade 5 unless otherwise noted. Grade 5 cap screws are marked with three radial lines on the head. If hardware must be replaced, be sure to replace it with hardware of equal size, strength and thread type. Refer to the torque values chart when tightening hardware.





 **Important:** Over tightening hardware can cause as much damage as when under tightening. Tightening hardware beyond the recommended range can reduce its shock load capacity.

The chart below is a guide for proper torque. Use it unless a specified torque is called out elsewhere in the manual.

Torque is the force you apply to the wrench handle or the cheater bar, times the length of the handle or bar.

Use a torque wrench whenever possible.

The following table shows torque in ft. lbs. for coarse thread hardware.

BOLT DIA. AND THREADS PER INCH		 OR 	
	GRADE 2	GRADE 5 A-325	GRADE 8
3/8-16	25	35	50
7/16-14	35	55	80
1/2-13	55	85	125
9/16-12	75	125	175
5/8-11	105	170	235
3/4-10	185	305	425
7/8-9	170	445	690
1-8	260	670	1030
1 1/8-7	365	900	1460
1 1/4-7	515	1275	2060
1 3/8-6	675	1675	2700
1 1/2-6	900	2150	3500
1 3/4-5	1410	3500	5600



Lubricate all bearings and moving parts as assembled and make certain that they work freely.

WARNING: Never work around the toolbar/implement while in a raised position without using safety lockups.



CAUTION: The 6200 Packer Wheel attachments are very heavy. Pay extra attention to lifting techniques while handling and or maneuvering the opener during assembly. Failure to do so may lead to personal injury.

ASSEMBLY

STEP 1. Attach the packer wheel mount bracket to the planter row unit using the provided hardware as illustrated for each model of planter.

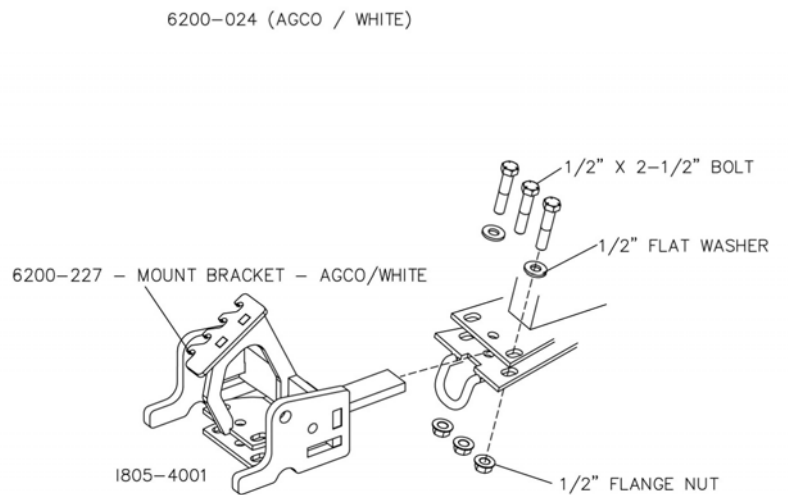
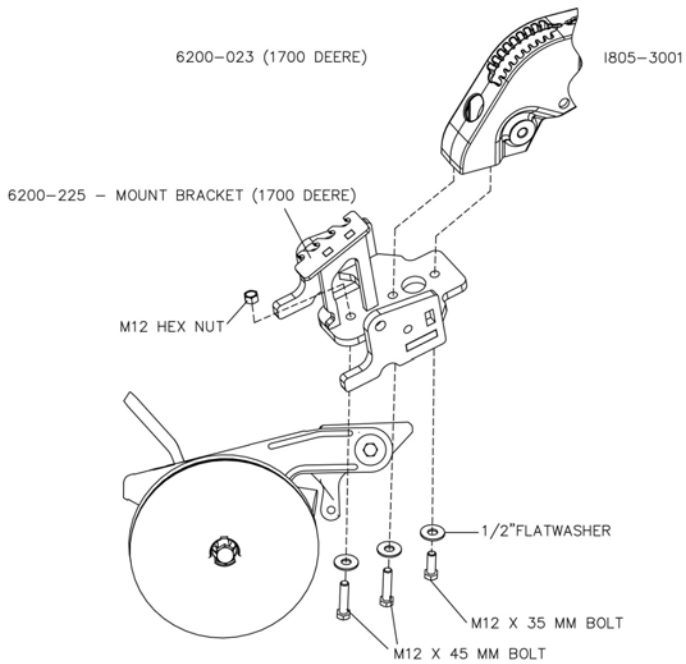
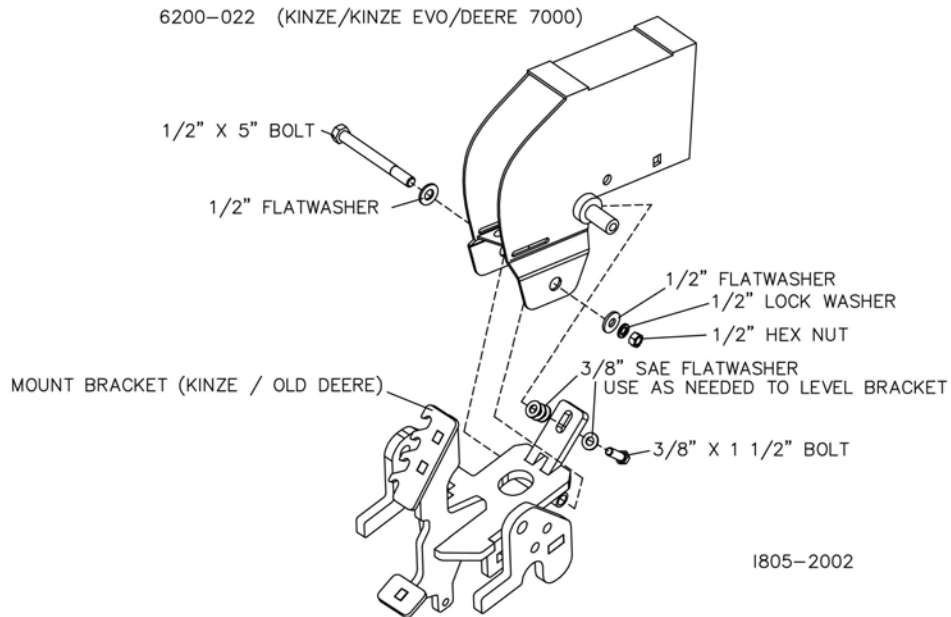

ASSEMBLY

STEP 2. Attach the v-closing wheel assembly to the packer wheel mount bracket. 1 x 12 are not shown for clarity of illustrations, 1 x 12 wheels are intended to be used with the 6200 packer wheel.

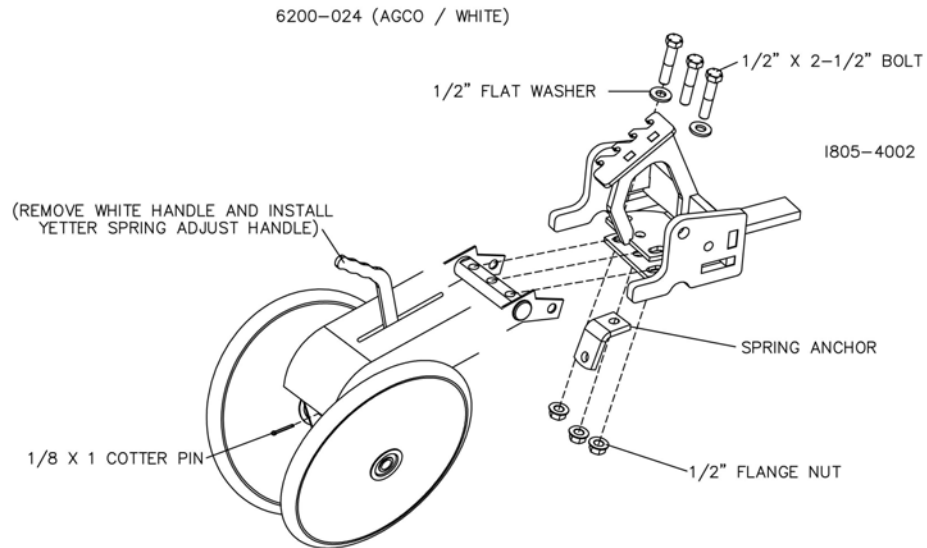
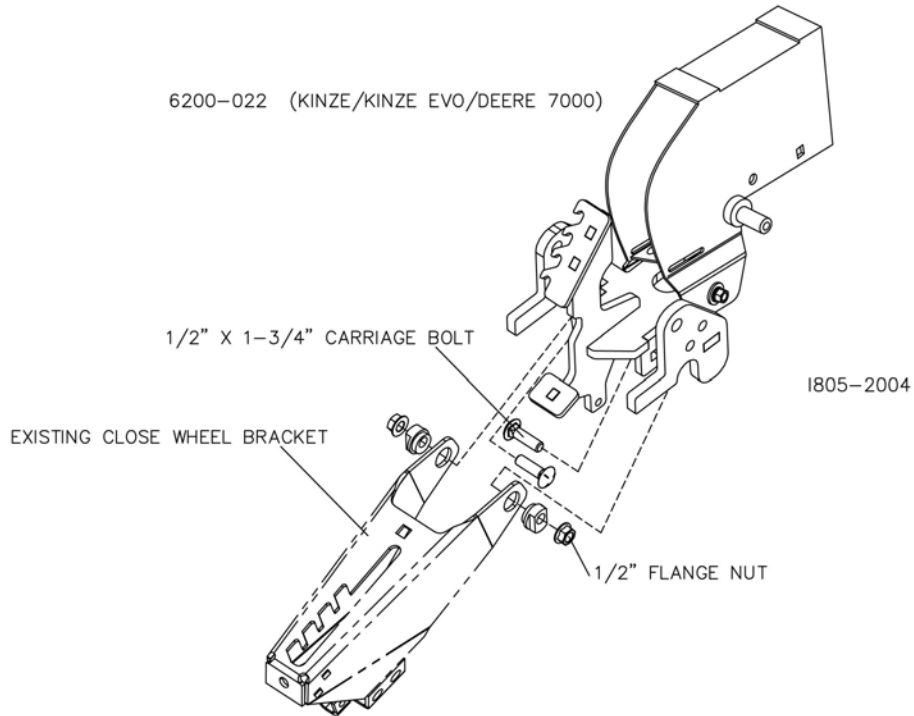

ASSEMBLY

STEP 3. Attach the spring stop, spring and height adjustment to the packer wheel arm.

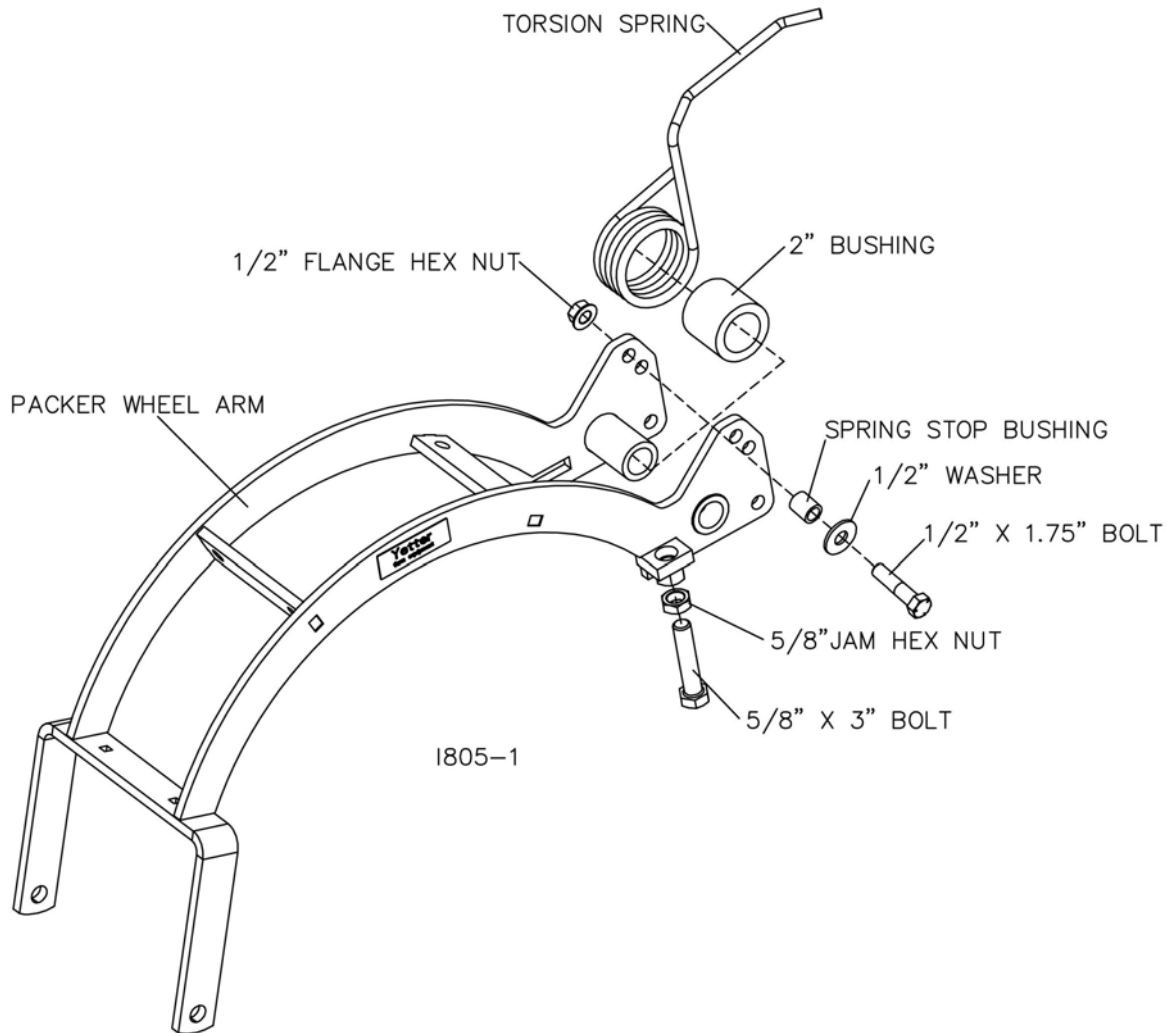

ASSEMBLY

STEP 4. Attach the packer wheel arm assembly to the mount bracket.

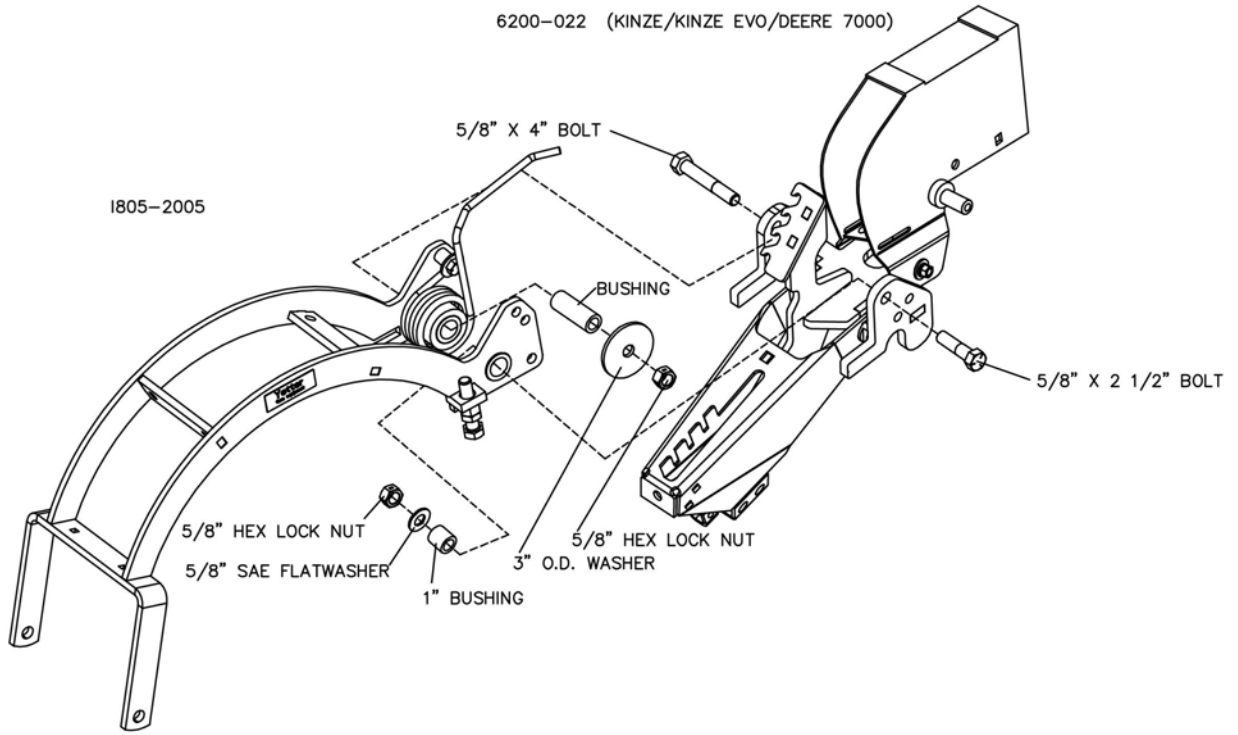

ASSEMBLY

STEP 5. Attach the 6.5" x 12" wheel to the packer wheel arm.

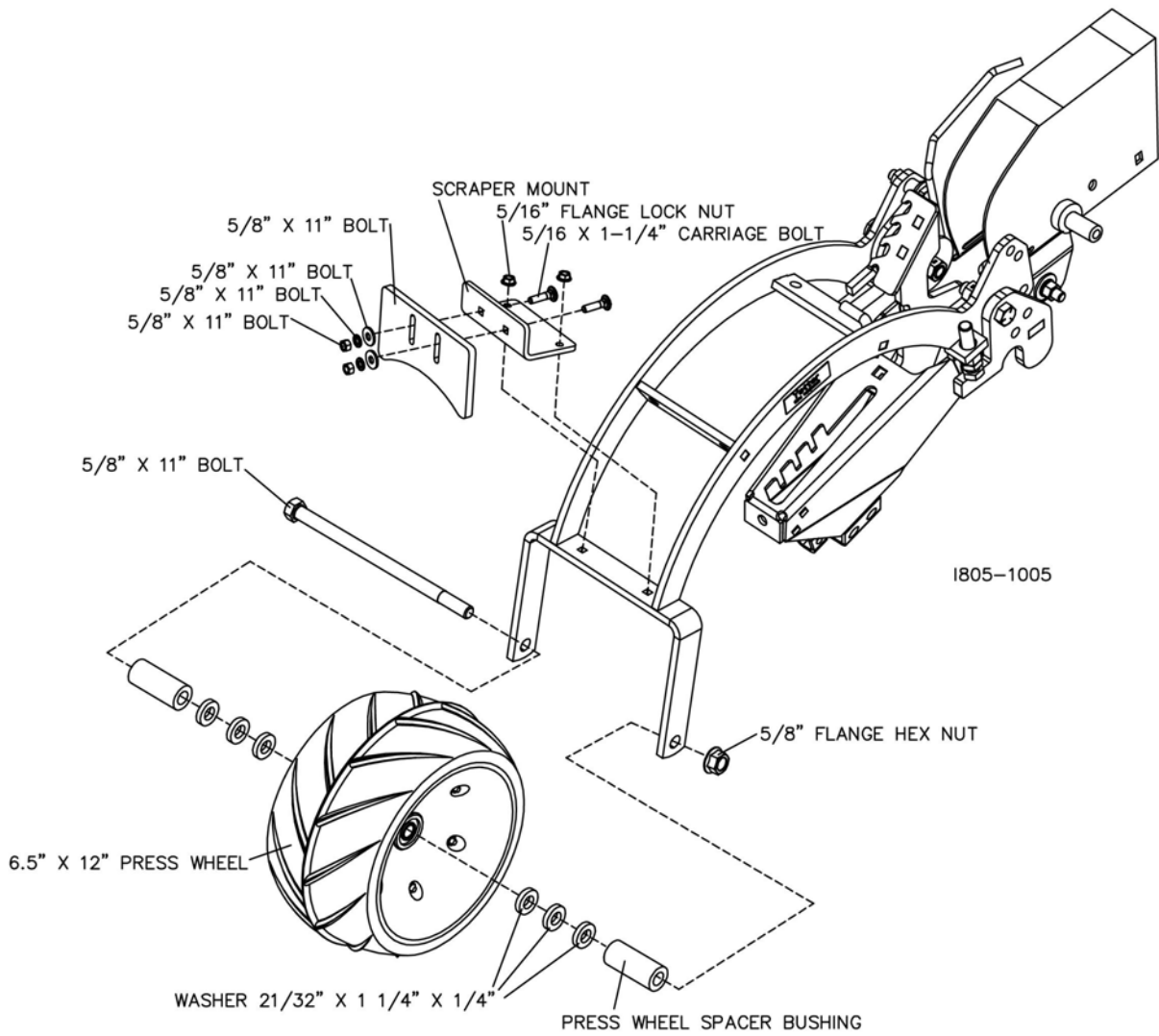

OPERATION

PLANTER ADJUSTMENT

Refer to planter manufacturer's manual for specific measurements and techniques on frame height adjustment.

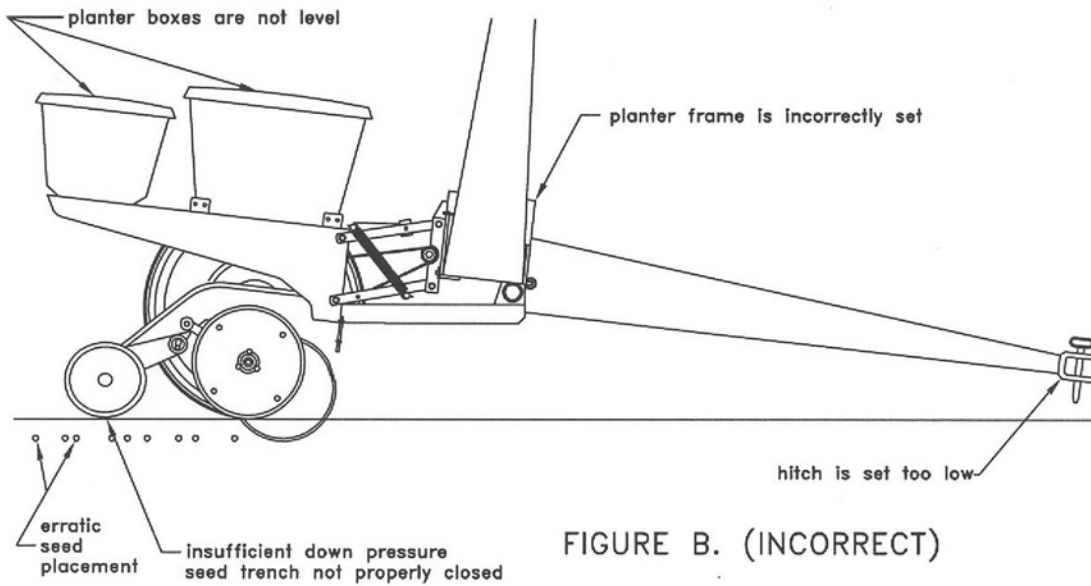
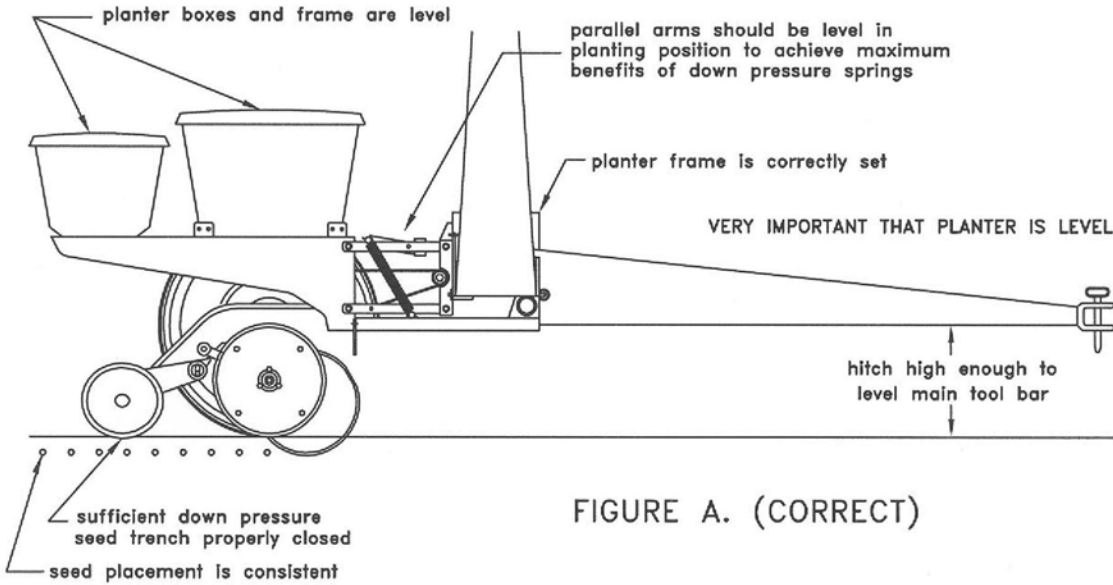

OPERATION ADJUSTMENT

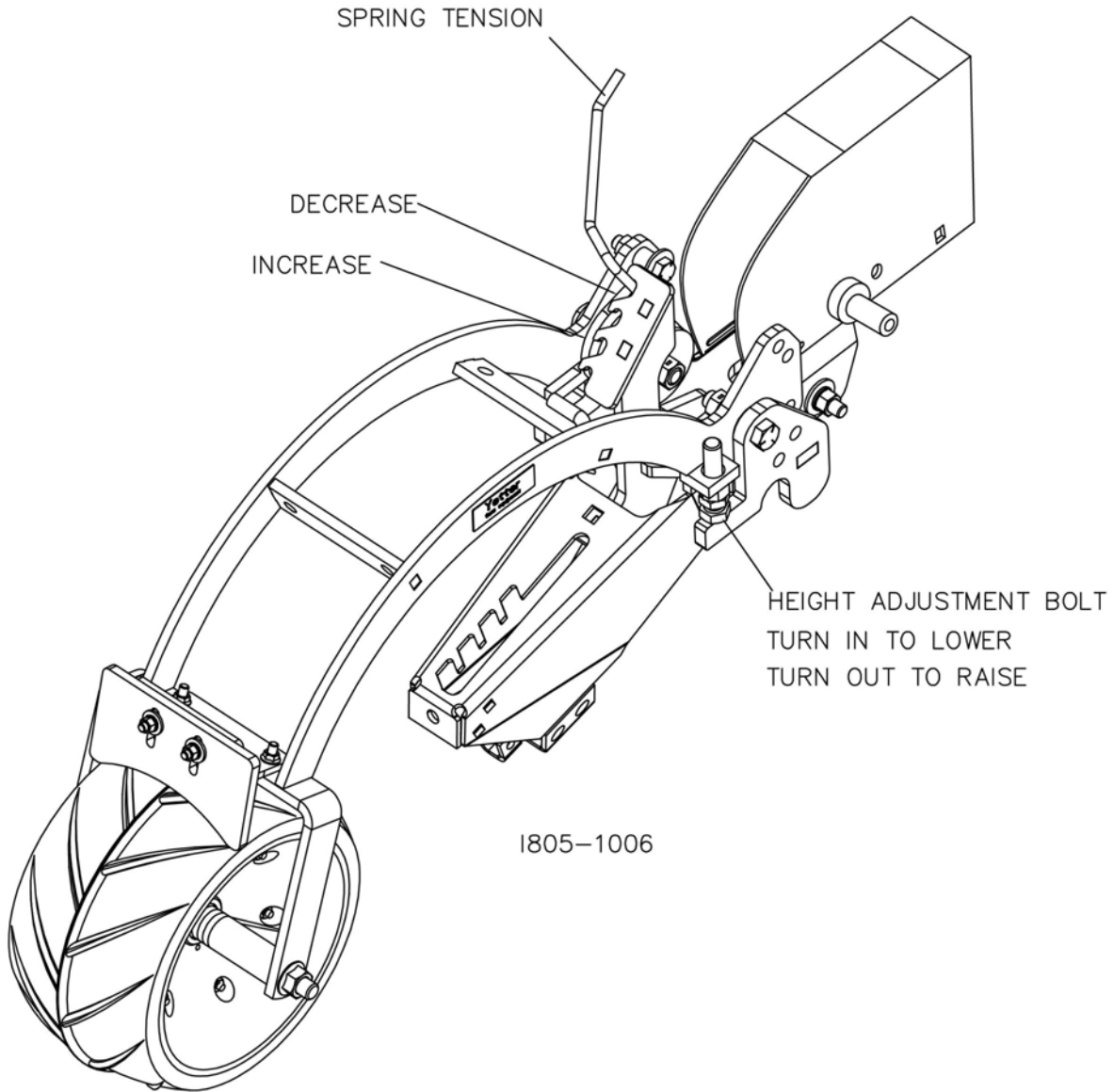

PARTS IDENTIFICATION

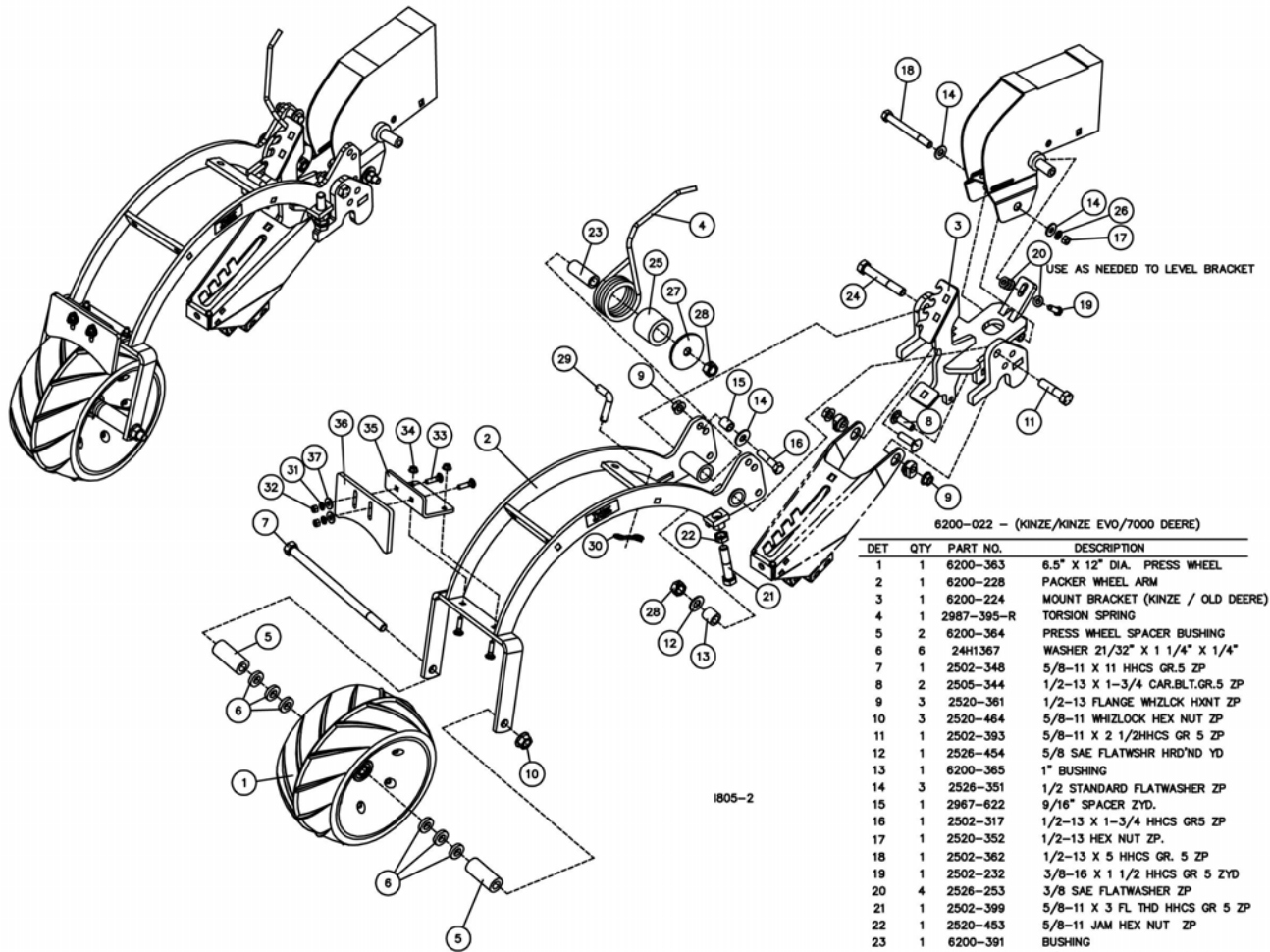

6200-022 - (KINZE/KINZE EVO/7000 DEERE)

DET	QTY	PART NO.	DESCRIPTION
1	1	6200-363	6.5" X 12" DIA. PRESS WHEEL
2	1	6200-228	PACKER WHEEL ARM
3	1	6200-224	MOUNT BRACKET (KINZE / OLD DEERE)
4	1	2987-395-R	TORSION SPRING
5	2	6200-364	PRESS WHEEL SPACER BUSHING
6	6	24H1367	WASHER 21/32" X 1 1/4" X 1/4"
7	1	2502-348	5/8-11 X 11 HHCS GR.5 ZP
8	2	2505-344	1/2-13 X 1-3/4 CAR.BLT.GR.5 ZP
9	3	2520-361	1/2-13 FLANGE WHZLCK HXNT ZP
10	3	2520-464	5/8-11 WHZLOCK HEX NUT ZP
11	1	2502-393	5/8-11 X 2 1/2HHCS GR 5 ZP
12	1	2526-454	5/8 SAE FLATWSHR HRD'ND YD
13	1	6200-365	1" BUSHING
14	3	2526-351	1/2 STANDARD FLATWASHER ZP
15	1	2967-622	9/16" SPACER ZYD.
16	1	2502-317	1/2-13 X 1-3/4 HHCS GR5 ZP
17	1	2520-352	1/2-13 HEX NUT ZP.
18	1	2502-362	1/2-13 X 5 HHCS GR. 5 ZP
19	1	2502-232	3/8-16 X 1 1/2 HHCS GR 5 ZYD
20	4	2526-253	3/8 SAE FLATWASHER ZP
21	1	2502-399	5/8-11 X 3 FL THD HHCS GR 5 ZP
22	1	2520-453	5/8-11 JAM HEX NUT ZP
23	1	6200-391	BUSHING
24	1	2502-336	5/8-11 X 4 HHCS GR. 5 ZP
25	1	6200-397	2.00" BUSHING ZYD.
26	1	2525-352	1/2 MED LOCKWASHER ZP
27	1	2527-534	3" OD X .656" ID X .188 THK WASHER ZP
28	2	2520-459	5/8-11 HEX LOCK NUT ZP.
29	1	2987-613	KANBAN TITAN PIN, JD, ZYD
30	1	2570-448	.120BOWTIE LOKING COTT ZYD
31	2	2525-201	5/16 MED LOCK WASHER ZP
32	2	2520-201	5/16-18 HEX NUT ZP.
33	4	2505-207	5/16-18 X 1-1/4 CAR BLT ZP
34	2	2520-206	5/16-18 HEX FLANGE LOCK NUT ZP.
35	1	6200-412	SCRAPER MOUNT
36	1	6200-413	SCRAPER
37	2	2526-201	5/16 STANDARD FLAT WASHER ZP.

UPDATED 01/29/14

PARTS IDENTIFICATION

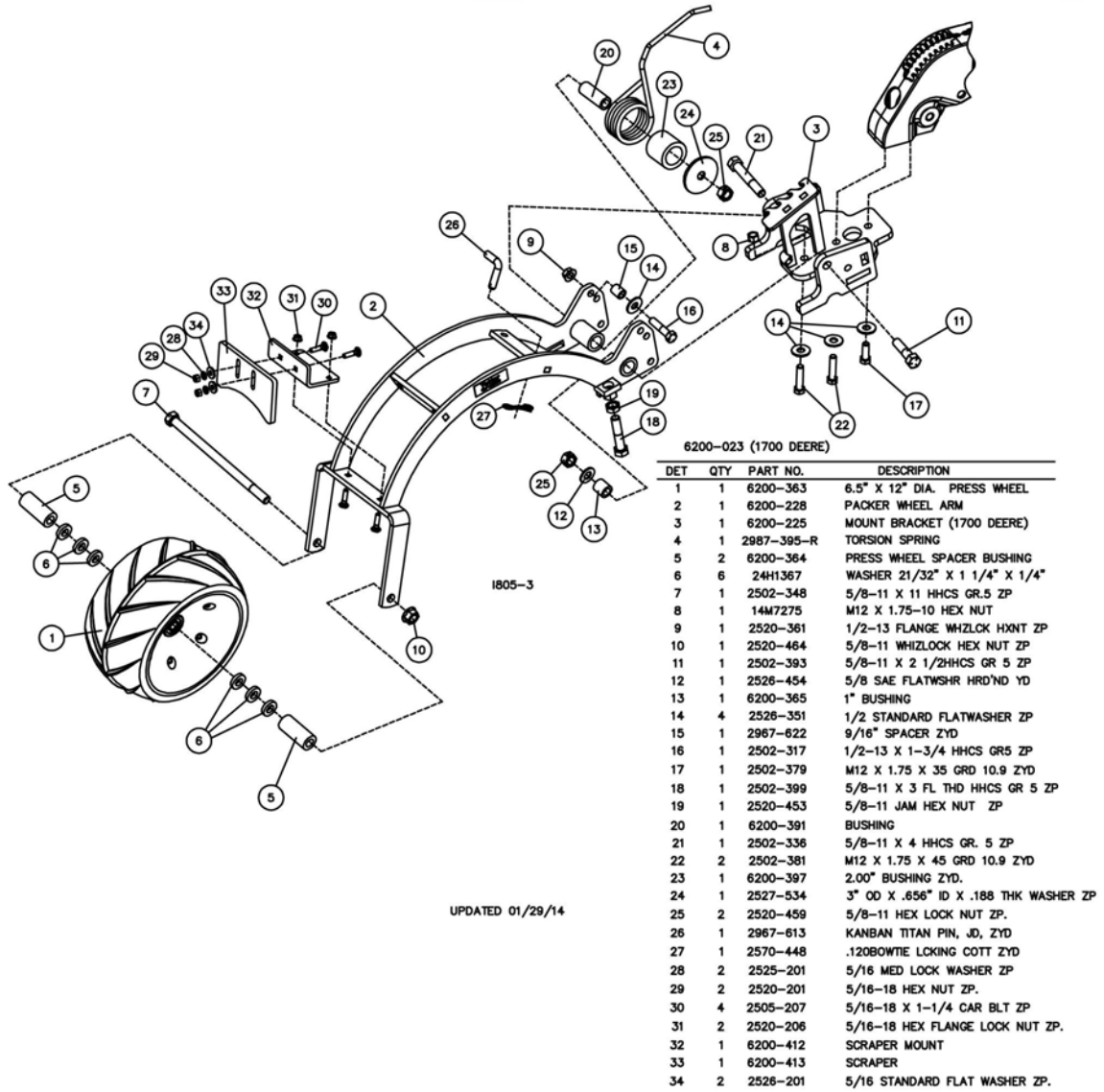

PARTS IDENTIFICATION

6200-024 (AGCO / WHITE)

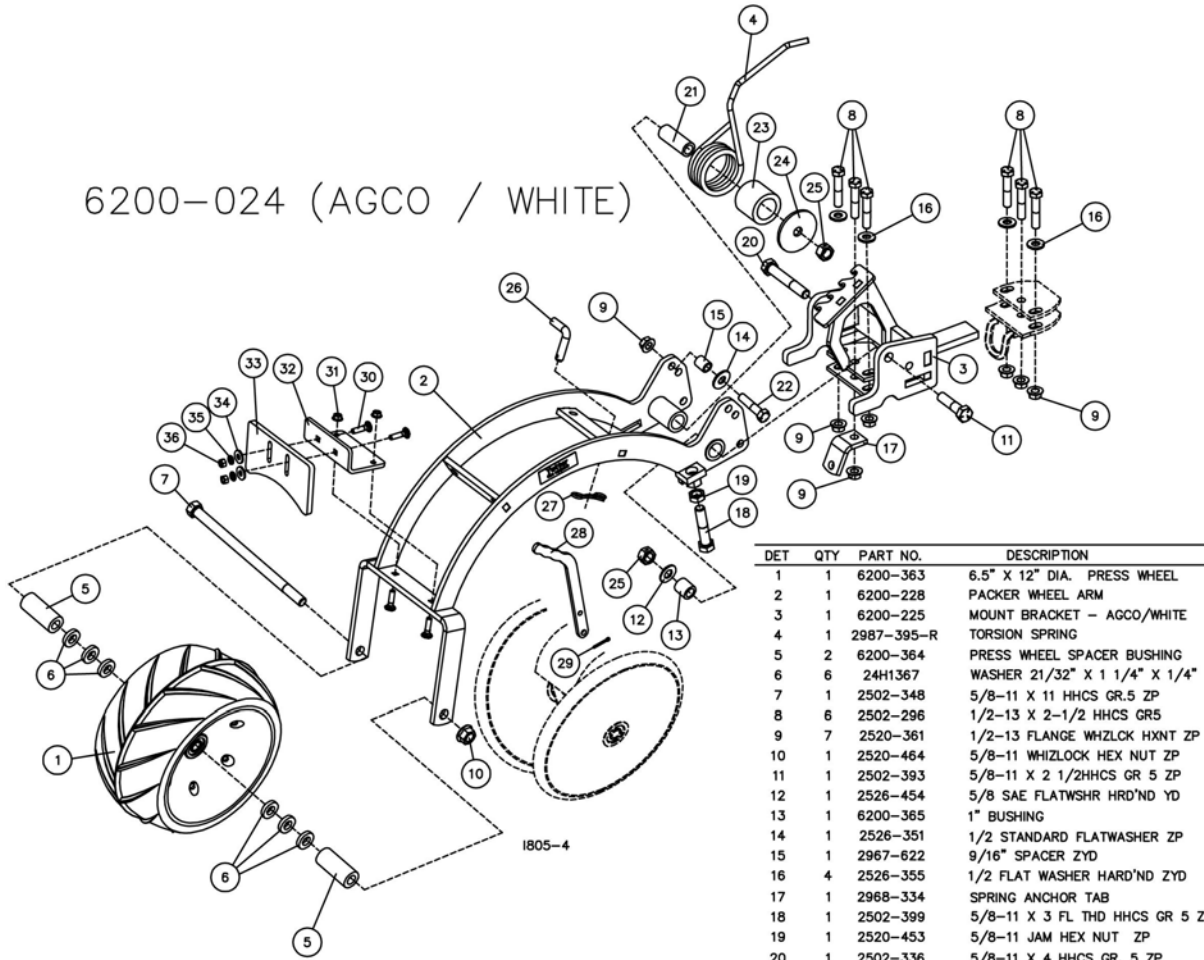

DET	QTY	PART NO.	DESCRIPTION
1	1	6200-363	6.5" X 12" DIA. PRESS WHEEL
2	1	6200-228	PACKER WHEEL ARM
3	1	6200-225	MOUNT BRACKET - AGCO/WHITE
4	1	2987-395-R	TORSION SPRING
5	2	6200-364	PRESS WHEEL SPACER BUSHING
6	6	24H1367	WASHER 21/32" X 1 1/4" X 1/4"
7	1	2502-348	5/8-11 X 11 HHCS GR.5 ZP
8	6	2502-296	1/2-13 X 2 1/2 HHCS GR5
9	7	2520-361	1/2-13 FLANGE WHZLCK HXNT ZP
10	1	2520-464	5/8-11 WHIZLOCK HEX NUT ZP
11	1	2502-393	5/8-11 X 2 1/2HHCS GR 5 ZP
12	1	2526-454	5/8 SAE FLATWSHR HRD'ND YD
13	1	6200-365	1" BUSHING
14	1	2526-351	1/2 STANDARD FLATWASHER ZP
15	1	2967-622	9/16" SPACER ZYD
16	4	2526-355	1/2 FLAT WASHER HARD'ND ZYD
17	1	2968-334	SPRING ANCHOR TAB
18	1	2502-399	5/8-11 X 3 FL THD HHCS GR 5 ZP
19	1	2520-453	5/8-11 JAM HEX NUT ZP
20	1	2502-336	5/8-11 X 4 HHCS GR. 5 ZP
21	1	6200-391	BUSHING
22	1	2502-317	1/2-13 X 1-3/4 HHCS GR5 ZP
23	1	6200-397	2.00" BUSHING ZYD.
24	1	2527-534	3" OD X .656" ID X .188 THK WASHER ZP
25	2	2520-459	5/8-11 HEX LOCK NUT ZP.
26	1	2967-613	KANBAN TITAN PIN, JD, ZYD
27	1	2570-448	.120BOWTIE LCKING COTT ZYD
28	1	6200-414	SPRING ADJUST HANDLE, WHITE
29	1	2531-107	1/8 X 1 COTTER PIN ZP
30	4	2505-207	5/16-18 X 1-1/4 CAR BLT ZP
31	2	2520-206	5/16-18 HEX FLANGE LOCK NUT ZP.
32	1	6200-412	SCRAPER MOUNT
33	1	6200-413	SCRAPER
34	2	2526-201	5/16 STANDARD FLAT WASHER ZP.
35	2	2525-201	5/16 MED LOCK WASHER ZP
36	2	2520-201	5/16-18 HEX NUT ZP.

UPDATED 01/29/14

NOTES:

Our name Is getting known

Just a few years ago, Yetter products were sold primarily to the Midwest only. Then we embarked on a program of expansion and moved into the East, the South, the West and now north into Canada. We're even getting orders from as far away as Australia and Africa.

So, when you buy Yetter products . . .you're buying a name that's recognized. A name that's known and respected. A name that's become a part of American agriculture and has become synonymous with quality and satisfaction in the field of conservation tillage.

Thank you.

YETTER MANUFACTURING CO.

Colchester, IL 62326-0358 • 309/776-4111

Toll Free 800/447-5777

Fax 309/776-3222

Website: WWW.YETTERCO.COM

E-MAIL: INFO@YETTERCO.COM

2565-776_REV_A • 02/2014