

1669

6200-108 - HD TWISTED LINK DRAG CHAIN KIT

DET	QTY	PART NO.	DESCRIPTION
1	2	2502-237	3/8-16 X 1" HHCS GR.5 ZP
2	2	6200-338	MOUNTING BRACKET
3	2	2526-253	3/8 SAE FLAT WASHER
4	2	2520-255	3/8-16 LOCK HEX NUT
5	2	6200-339	5/16 SPLIT CONNECTING LINK
6	1	6200-340	19 LINK TWISTED CHAIN

YETTER MANUFACTURING CO.
 FOUNDED 1930

Colchester, IL 62326-0358
 Toll free: 800/447-5777
 309/776-3222 (Fax)
 Website: www.yetterco.com
 E-mail: info@yetterco.com

YETTER

INSTALLATION / ASSEMBLY INSTRUCTIONS

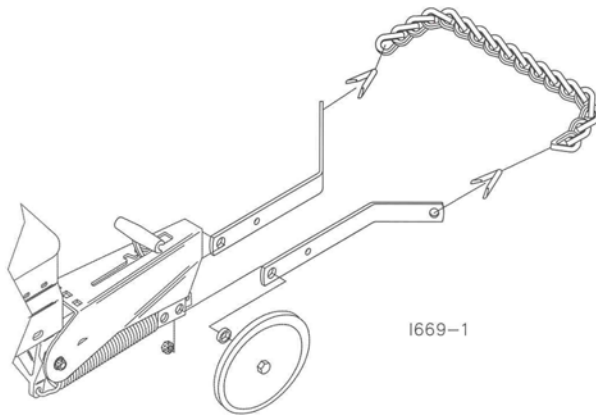

STYLE 1. Attaching drag chain kit to closing wheel arm with bolt on wheels. Discard two of the flat washers or spacer if necessary and install the bracket as shown in drawing to the left. Note: Keep the 1 x 12 closing wheels spaced $1\frac{1}{4}$ "- $1\frac{1}{2}$ " apart and the spike wheels spaced 2 " - $2\frac{1}{2}$ " apart. Securely tighten hardware.

STYLE 2. Attaching drag chain kit to closing wheel arm without holes or bolt on wheels. Drill a $1\frac{3}{32}$ " hole on each side of arm. Locate hole as shown in drawing to the right. Using $\frac{3}{8}$ " x 1" hex bolt, flat washer and locknut, attach brackets as shown. Securely tighten hardware.

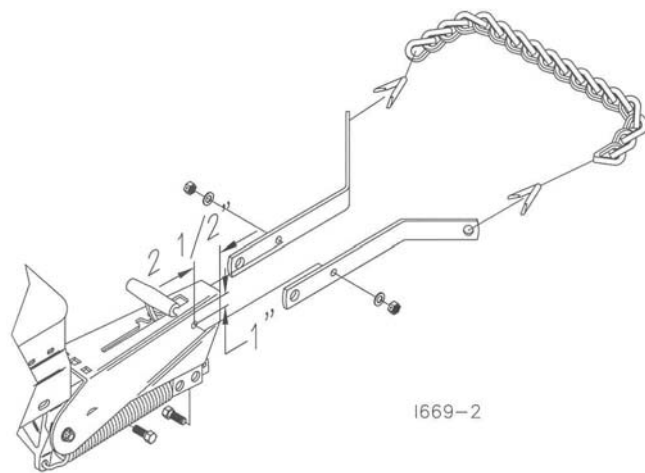

STYLE 3. Attaching drag chain kit to closing wheel arm with holes provided. Attach brackets as shown in drawing to the left using $\frac{3}{8}$ " x 1" hex bolt, flat washer and locknut. Securely tighten hardware.

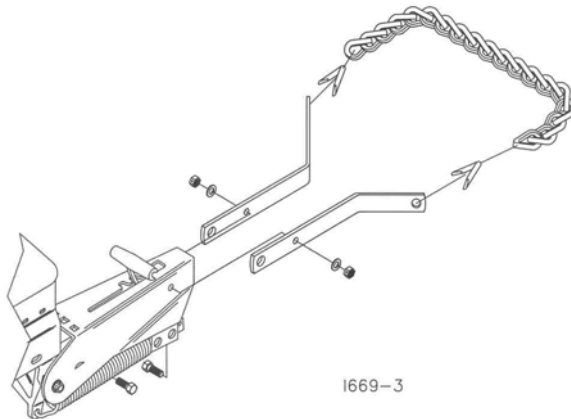

Adjustments: Position brackets to carry front of chain about 3" to 4" above soil. Securely tighten hardware. For best soil leveling, keep front end of the chain as low as possible while maintaining clearance above the soil for the bracket ends. Use drag chains when planting in minimum till or in no-till where at least some of the soil surface is dry.

NOTE: As with any type of furrow closing device it is advisable to do in field checks and make adjustments as necessary. There is no substitute for visual inspection to verify that the seed is being properly placed. Careful attention is required when using herbicide and/or insecticide, consult your chemical provider for compatibility.

6200-108 DRAG CHAIN APPLICATION CHART

MAKE	MODEL	40 MM BEARING BOLT ON WHEEL	WATER PUMP BEARING W/ HOLES IN ARM	WATER PUMP BEARING W/O HOLES IN ARM	BOLT ON WHEEL HOLES IN ARM	WHERE TO ATTACH 6200-108 DRAG CHAIN
YETTER	6000-002	X				MOUNT TO WHEEL BOLT
JOHN DEERE	7000/ME		X			MOUNT TO HOLES IN ARM
	7200/ME II				X	MOUNT TO HOLES IN ARM
	1700/ME II PLUS	X				MOUNT TO WHEEL BOLT
KINZE	PRE-1993			X		DRILL HOLES
	1993-PRESENT	X				MOUNT TO WHEEL BOLT
WHITE	5100		X			MOUNT TO HOLES IN ARM
	6100	X				MOUNT TO WHEEL BOLT
	8000	X				MOUNT TO WHEEL BOLT
GREAT PLAINS	ALL	X				MOUNT TO WHEEL BOLT
LANDOLL/DEUTZ-ALLIS	ALL	N/A	N/A	N/A	N/A	N/A
MONOSEM	NG PLUS	X				MOUNT TO WHEEL BOLT
SHOUP	CW 7050		X			MOUNT TO HOLES IN ARM
	CW 3000		X			MOUNT TO HOLES IN ARM
CASE/ NEW HOLLAND	ALL	N/A	N/A	N/A	N/A	N/A

TROUBLE SHOOTING

PROBLEM

Drag chain not doing much

Drag chain gets caught on spike wheel or chain bracket

SOLUTION

Chain bracket needs to be 3" – 4" above soil so more of chain contacts soil

Install Residue Manager

Install a deflector. Weld a "U" shaped bar of round rod to the

Our name Is getting known

Just a few years ago, Yetter products were sold primarily to the Midwest only. Then we embarked on a program of expansion and moved into the East, the South, the West and now north into Canada. We're even getting orders from as far away as Australia and Africa.

So, when you buy Yetter products . . .you're buying a name that's recognized. A name that's known and respected. A name that's become a part of American agriculture and has become synonymous with quality and satisfaction in the field of conservation tillage.

Thank you.

YETTER MANUFACTURING CO.
Colchester, IL 62326-0358 ☎ 309/776-4111
Toll Free 800/447-5777
Fax 309/776-3222
Website: www.yetterco.com
E-mail: info@yetterco.com