

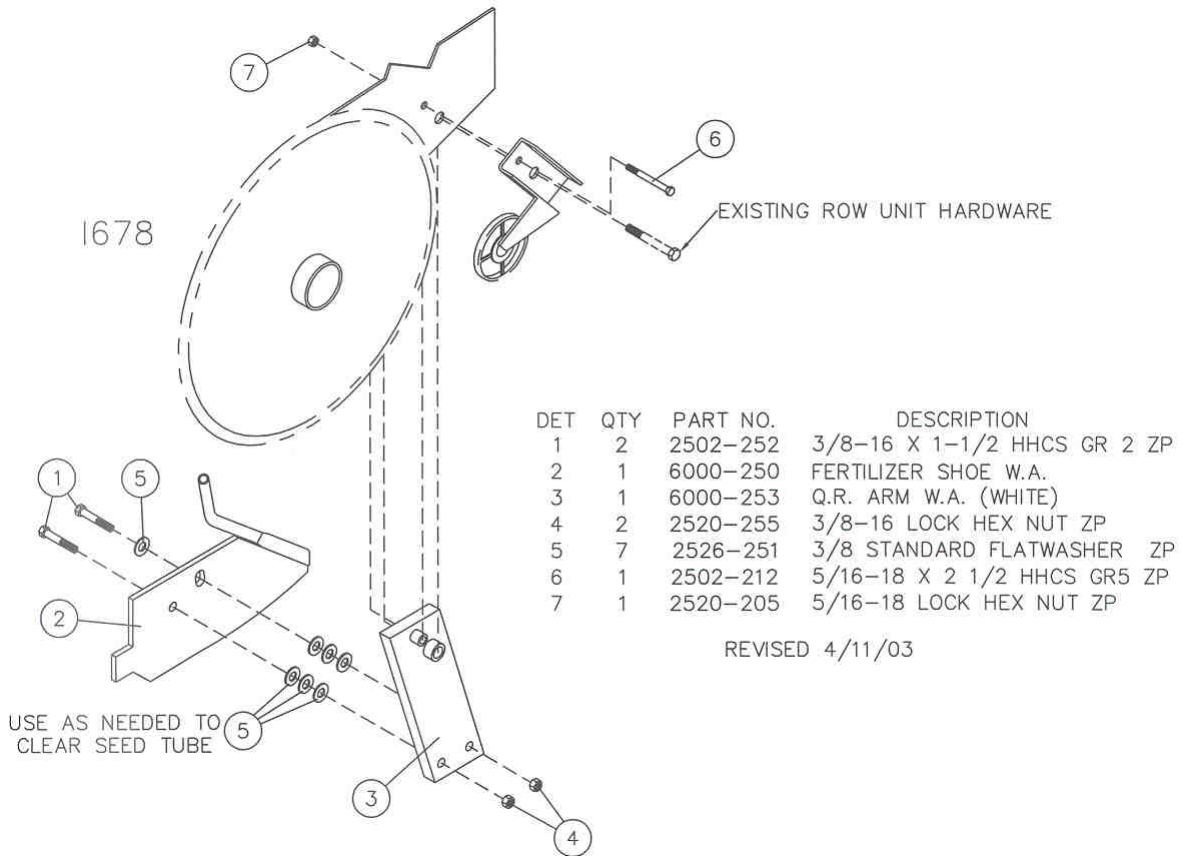

6000-008

QUICK RESPONSE SHOE ASSEMBLY INSTRUCTIONS ON WHITE 6000/8000



ASSEMBLY INSTRUCTIONS

1. Remove gauge wheel arm assemblies from the row unit.
2. Remove the scrapers.
3. Check the seed opener blades for 2" of blade edge contact. Check your planter operator's manual for correct adjustment procedure. NOTE: this adjustment is critical for correct installation and adjustment of the Quick Response Shoe.
4. Remove the R.H. seed opener disk blade.
5. Attach the 6000-253 arm to the planter unit using 5/16" x 2-1/2" and 1/2" X 2 1/2" bolts. NOTE: do not assemble scrapers at this time because the R.H. seed opener blade has been removed to determine the number of shims needed to have proper clearance between the seed tube and the 6000-250 fertilizer shoe.

IMPORTANT:

The fertilizer shoe must not touch the seed tube, use shims between the 6000-253 arm and the 6000-250 shoe. **DO NOT REMOVE** the "tab" on the shoe to achieve the necessary clearance.

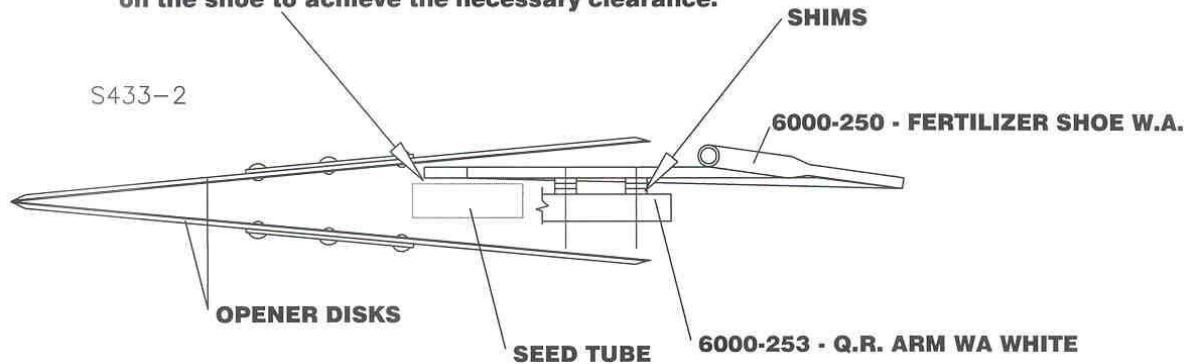

Securely fasten the 6000-250 shoe to the 6000-253 arm using two 3/8" x 1-1/2" bolts, washers and locknuts.

6. Replace blade, bearing washer, nut and cap. NOTE: the 6000-250 shoe should rub the blade and blades should turn with some resistance, if the blades have difficulty turning the are most likely worn too small and should be replaced.
7. Remove the two mounting bolts for the 6000-253 arm to the row unit.
8. Install the scrapers using the two 5/16" x 2-1/2" and 1/2" x 2 1/2" bolts and lock nuts. NOTE: Use shims as necessary between the scraper and the row unit to apply correct tension on the scrapers. Over tightening scrapers may prevent opener disks from turning properly and or may cause premature scraper wear.

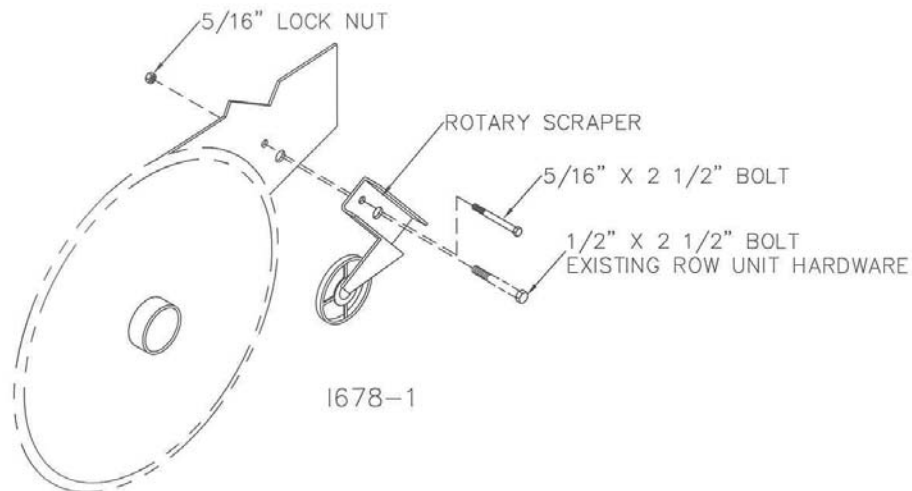

9. Install the gauge wheel arm assemblies and adjust to prevent a buildup of dirt or residue between gauge wheels and blades, be certain wheels are positioned correctly against disk blades. Gauge wheel tires should just touch the blades, or be no more than 1/16" away from blades at their closest point.
10. Adjust fertilizer shoe depth by loosening the rear 3/8" x 1-1/2" bolt, raise the shoe for a more shallow fertilizer placement or lower the shoe for deeper fertilizer placement. **IMPORTANT:** It is best to consult the fertilizer supplier for optimum placement when placing starter fertilizer in close proximity to the seed. NOTE: If there is a buildup of damp soil the planter gauge wheels or opener disks, then conditions are less than "ideal" and some problems may also be encountered with the Quick Response Shoe. In some situations it may be advisable to remove the Quick Response Shoe from the planter unit, if the problem continues.