

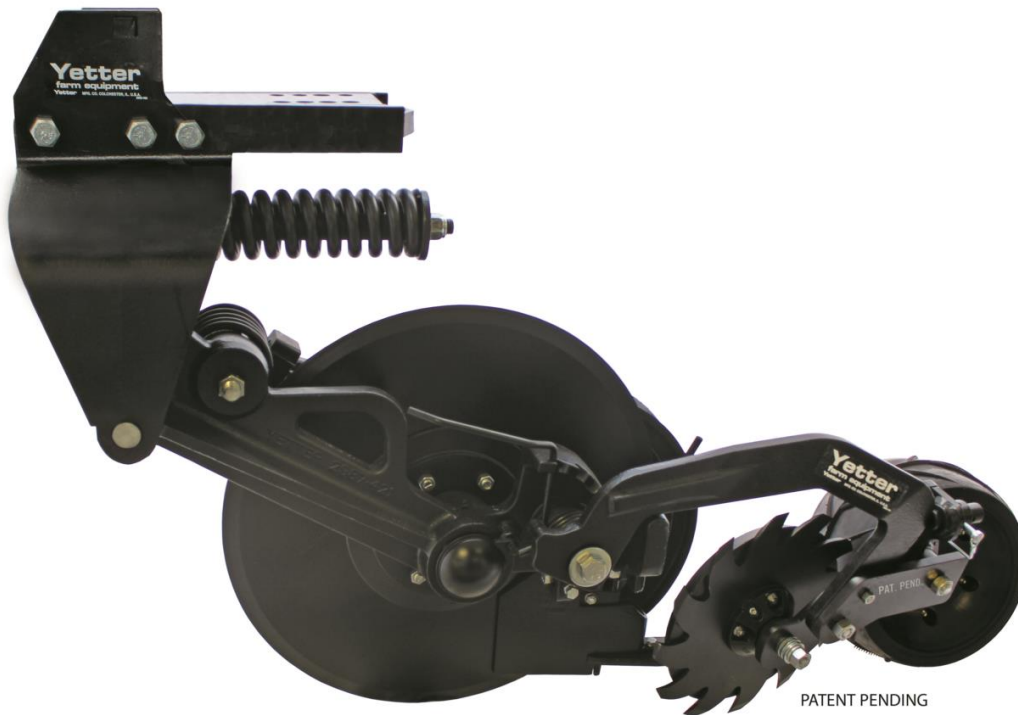

10000 SERIES MAGNUM™ FERTILIZER COULTER

2565-957_Rev_G 8/2022



YETTER MANUFACTURING CO.

Founded 1930

Colchester, IL 62326-0358

Toll free: 800-447-5777

Fax: 309-776-3222

Website: www.yetterco.com

Email: info@yetterco.com

YETTER

FOREWORD

You've just joined an exclusive but rapidly growing club.

For our part, we want to welcome you to the group and thank you for buying a Yetter product.

We hope your new Yetter products will help you achieve both goals-increase your productivity and increase your efficiency so that you may generate more profit.

This operator's manual has been designed into four major sections: Foreword, Safety Precautions, Installation Instructions and Parts Breakdown.

This **SAFETY ALERT SYMBOL** indicates important safety messages in the manual. When you see this symbol, be alert to the possibility of **PERSONAL INJURY** and carefully read the message that follows.



The word **NOTE** is used to convey information that is out of context with the manual text. It contains special information such as specifications, techniques and reference information of a supplementary nature.

The word **IMPORTANT** is used in the text when immediate damage will occur to the machine due to improper technique or operation. Important will apply to the same information as specified by note only of an immediate and urgent nature.

It is the responsibility of the user to read the operator's manual and comply with the safe and correct operating procedure and to lubricate and maintain the product according to the maintenance schedule in the operator's manual.

The user is responsible for inspecting his machine and for having parts repaired or replaced when continued use of the product would cause damage or excessive wear to the other parts.

It is the user's responsibility to deliver his machine to the Yetter dealer who sold him the product for service or replacement of defective parts, which are covered by the warranty policy.

If you are unable to understand or follow the instructions provided in this publication, consult your local Yetter dealer or contact:

YETTER MANUFACTURING CO.

309/776-4111

800/447-5777

309/776-3222 (FAX)

Website: www.yetterco.com

E-mail: info@yetterco.com

WARRANTY

Yetter Manufacturing warrants all products manufactured and sold by it against defects in material. This warranty being expressly limited to replacement at the factory of such parts or products as shall appear to be defective after inspection. This warranty does not obligate the Company to bear cost of labor in replacement of parts. It is the policy of the Company to make improvements without incurring obligations to add them to any unit already sold. No warranty is made or authorized to be made, other than herein set forth. This warranty is in effect for one year after purchase.

DEALER: _____

Yetter Manufacturing warrants its own products only and cannot be responsible for damages to equipment on which mounted.

TABLE OF CONTENTS

Foreword	2
Safety	4
Torque	5
General Information.....	6-7
Assembly Instructions	8-9
Operation.....	10-12
Troubleshooting	13
Maintenance	14-18
Part Identification	19-47



BE ALERT! YOUR SAFETY IS INVOLVED.

WATCH FOR THIS SYMBOL. IT POINTS OUT IMPORTANT SAFETY PRECAUTIONS. IT MEANS "ATTENTION---BECOME ALERT!"



It is your responsibility as an owner, operator, or supervisor to know and instruct everyone using this machine at the time of initial assignment and at least annually thereafter, of the proper operation, precautions, and work hazards which exist in the operation of the machine in accordance with OSHA regulations.

Safety Is No Accident



The following safety instructions, combined with common sense, will save your equipment from needless damage and the operator from unnecessary exposure to personal hazard. Pay special attention to the caution notes in the text. Review this manual at least once each year with new and/or experienced operators.

1. **Read and understand the operator's manual before operating this machine. Failure to do so is considered a misuse of the equipment.**
2. **Make sure equipment is secure before operating.**
3. **Always keep children away from equipment when operating.**
4. **Make sure everyone that is not directly involved with the operation is out of the work area before beginning the operation.**
5. **Make sure all safety devices, shields, and guards are in place and are functional before beginning the operation.**
6. **Shut off power to adjust, service, or clean.**
7. **Keep hands, feet, and clothing away from moving parts. It is a good idea to remove all jewelry before starting the operation.**
8. **Visually inspect the machine periodically during operation for signs of excessive vibration, loose fasteners, and unusual noises.**

WARNING: Never work around the toolbar/implement while in a raised position without using safety lockups.



CAUTION: The 10000 Series Magnum™ coulters are very heavy. Pay extra attention to lifting techniques when handling or maneuvering the coulters during assembly. Failure to do so may lead to personal injury.

BOLT TORQUE

Before operating the 10000 Series Magnum™ for the first time, check to be sure that all hardware is tight. Check all hardware again after approximately 50 hours of operation and at the beginning of each planting season.

All hardware used on the 10000 Series Magnum™ is Grade 5 unless otherwise specified. Grade 5 cap screws are marked with three radial lines on the head. If hardware must be replaced, be sure to replace it with hardware of equal size, strength and thread type. Refer to the torque table below when tightening hardware.







Important: Over tightening hardware can cause as much damage as when under tightening. Tightening hardware beyond the recommended range can reduce its shock load capacity.

The chart below is a guide for proper torque. Use it unless a specified torque is called out elsewhere in the manual.

Torque is the force you apply to the wrench handle or the cheater bar, times the length of the handle or bar.

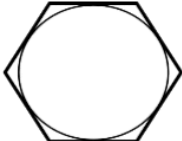
Use a torque wrench whenever possible.

The following table shows torque in ft. lbs. for coarse thread hardware.

Bolt Diameter and Threads per Inch	 Grade 2	 Grade 5	 A-325	 Grade 8
1/4	6	10		14
5/16	12	20		30
3/8 – 16	25	35		50
7/16 – 14	35	55		80
1/2 – 13	55	85		125
9/16 – 12	75	125		175
5/8 – 11	105	170		235
3/4-10	185	305		425
7/8 – 9	170	445		690
1-8	260	670		1030
1 1/8 – 7	365	900		1460
1 1/4 - 7	515	1275		2060
1 3/8 – 6	675	1675		2700
1 1/2 - 6	900	2150		3500
1 3/4 – 5	1410	3500		5600

GENERAL INFORMATION

10000 Series Magnum™ Fertilizer Coulter

STANDARD FEATURES FOR ALL MODELS

- High application speeds with minimal soil disturbance for fall, pre-plant, and side-dressing applications
- Tube kits for applying liquid, dry, or anhydrous
- All cast design
- Spring loaded knife with carbide tip for extended wear
- 22.6" blade set at 4° angle.
- Fits 4x4, 4x6, 5x7, 6x4, and 7x7 toolbar sizes
- Sharktooth® Wheel Closer standard

ORDER from SECTIONS: A, B, and C

Section A:

Model No.	Description	Est. Wt. (lbs)
10000-001-LH	LH Magnum, w/ Walking Tandem, fits toolbars 4,5,6,7 wide univ. mount	380
10000-001-RH	RH Magnum, w/ Walking Tandem, fits toolbars 4,5,6,7 wide univ. mount	380
10000-002-LH	LH Magnum, w/ Walking Tandem, fits toolbars 4" wide, Short mount	375
10000-002-RH	RH Magnum, w/ Walking Tandem, fits toolbars 4" wide, Short mount	375
10000-003-LH	LH Magnum, w/o Walking Tandem, fits toolbars 4,5,6,7 wide univ. mount	355
10000-003-RH	RH Magnum, w/o Walking Tandem, fits toolbars 4,5,6,7 wide univ. mount	355
10000-004-LH	LH Magnum, w/o Walking Tandem, fits toolbars 4" wide, Short mount	345
10000-004-RH	RH Magnum, w/o Walking Tandem, fits toolbars 4" wide, Short mount	345

Section B:

Model No.	Description	Est. Wt. (lbs)
2987-040-L	LH NH3 (3/8") Tube Kit	.395
2987-040-R	RH NH3 (3/8") Tube Kit	.395
2987-041-L	LH NH3 w/ Liquid (3/8" Dual) Tube Kit	.697
2987-041-R	RH NH3 w/ Liquid (3/8" Dual) Tube Kit	.697
2987-042-L	LH NH3 w/ Vapor (3/8" and 3/4") Tube Kit	.954
2987-042-R	RH NH3 w/ Vapor (3/8" and 3/4") Tube Kit	.954
2987-043-L	LH NH3 w/ Liquid and Vapor (3/8" Dual and 3/4" Single) Tube Kit	1.044
2987-043-R	RH NH3 w/ Liquid and Vapor (3/8" Dual and 3/4" Single) Tube Kit	1.044
2987-044-L	LH Vapor Only (3/4") Tube Kit	.455
2987-044-R	RH Vapor Only (3/4") Tube Kit	.455
2987-046	Liquid (1/2" Single) Tube Kit	.425
2987-047	Liquid (1/2" Dual) Tube Kit	.850
10000-050-LH	LH Magnum Dry Tube Assembly Kit	1.500
10000-050-RH	RH Magnum Dry Tube Assembly Kit	1.500

Section C:

Model No.	Description	Est. Wt. (lbs)
10000-011	4" Tall Toolbar Mount Hardware Kit	4
10000-012	5" Tall Toolbar Mount Hardware Kit	4.1
10000-013	6" Tall Toolbar Mount Hardware Kit	4.3
10000-014	7" Tall Toolbar Mount Hardware Kit	4.5

Optional Equipment:

Model No.	Description	Est. Wt. (lbs)
10000-020-LH	LH Walking Tandem Wheel Conversion Kit	28.5
10000-020-RH	RH Walking Tandem Wheel Conversion Kit	28.5
10000-099	2" Drop Down Kit (For Wheel Tracks)	16.4

GENERAL INFORMATION

10000 Magnum™ Fertilizer Coulter

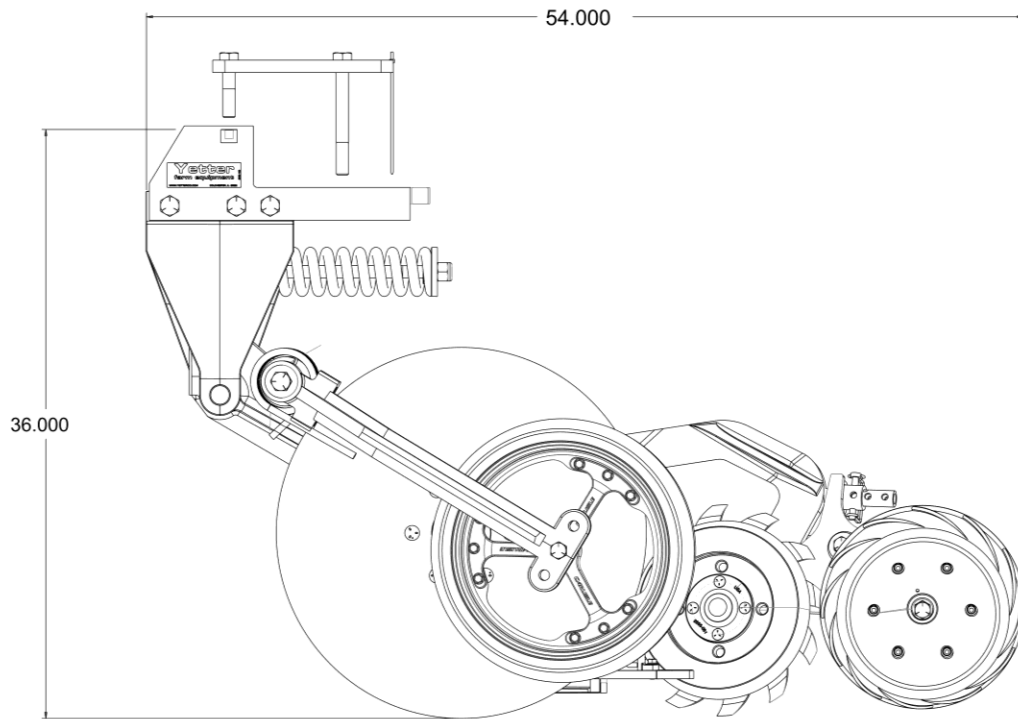
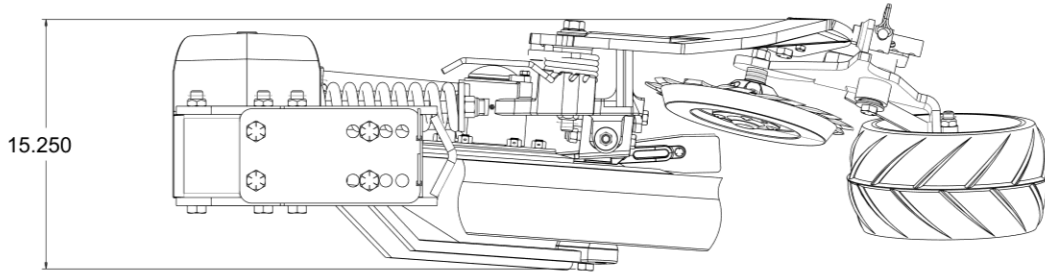

ASSEMBLY INSTRUCTIONS



WARNING: Never work under the toolbar while in a raised position without using safety lockups.



WARNING: Use extreme caution, the blade is sharp and may cause bodily injury. The coulter can be mounted to the toolbar using different techniques. One way is to mount the main arm assembly to the toolbar and then attach the components one at a time. Another way is to completely assemble the coulter before attaching to the toolbar frame.



CAUTION: 10000 Magnum™ Fertilizer Coulter and its components are very heavy. Extra attention to lifting techniques while handling and or maneuvering the coulter during assembly is very important. **Failure to do so may lead to personal injury or death.**

STEP 1: Mark the toolbar frame as to the location that each coulter is to be mounted.

IMPORTANT: Install an equal quantity of right hand and left hand coulters to each section of the toolbar. Example: A 30' – 3 section toolbar with 12 coulters (6R & 6L) will need to install 2R and 2L coulters on each section of the toolbar. If any questions concerning assembly of coulters, then please contact Yetter Farm Equipment for recommendations at 800-447-5777.

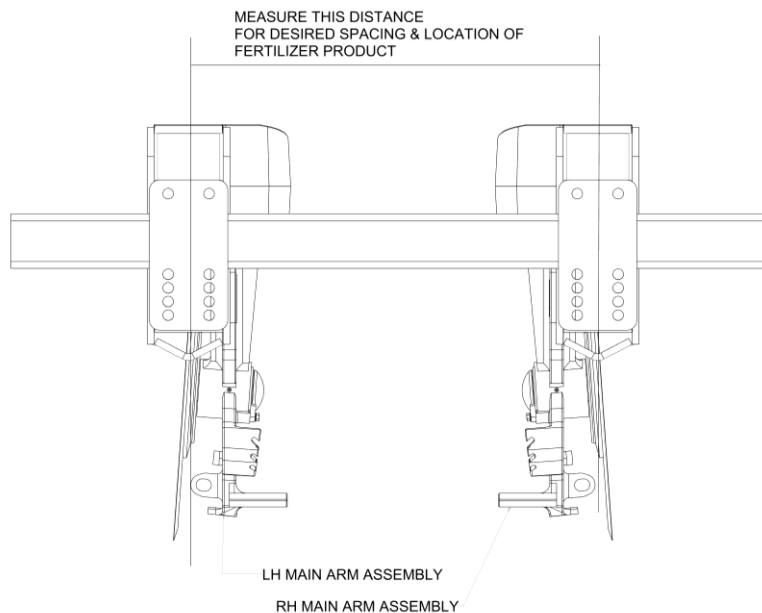

Note: The coulter blade is in line with the center of the mount bracket. Measure from left edge to left edge or from right edge to right edge to ensure the coulters are mounted at the desired spacing.

ASSEMBLY INSTRUCTIONS

STEP 2: Attach the 10000 Series Magnum™ to the toolbar using the appropriate clamp and hardware.

HARDWARE KITS PART IDENTIFICATION

10000-011 4" TALL TOOLBAR MOUNT KIT

ITEM	PART NO.	DESCRIPTION	QTY
1	2502-401	3/4-10 X 3-1/2 HHCS GRADE 5, ZP	2
2	2502-509	3/4-10 X 7 HHCS GRADE 5, ZP	2
3	2520-506	3/4-10 HEX NUT, GR 8, ZP	2
4	2525-501	3/4 MED LOCKWASHER ZP	4

10000-012 5" TALL TOOLBAR MOUNT KIT

ITEM	PART NO.	DESCRIPTION	QTY
1	2502-404	3/4-10 X 4 HHCS GRADE 5, ZP	2
2	2502-408	3/4-10 X 7-1/2 HHCS GRADE 5, ZP	2
3	2520-506	3/4-10 HEX NUT, GR 8, ZP	2
4	2525-501	3/4 MED LOCKWASHER ZP	4

10000-013 6" TALL TOOLBAR MOUNT KIT

ITEM	PART NO.	DESCRIPTION	QTY
1	2502-507	3/4-10 X 5 HHCS GRADE 5, ZP	2
2	2502-514	3/4-10 X 9 HHCS GRADE 5, ZP	2
3	2520-506	3/4-10 HEX NUT, GR 8, ZP	2
4	2525-501	3/4 MED LOCKWASHER ZP	4

10000-014 7" TALL TOOLBAR MOUNT KIT (SHOWN)

ITEM	PART NO.	DESCRIPTION	QTY
1	2502-510	3/4-10 X 6 HHCS GRADE 5, ZP	2
2	2502-516	3/4-10 X 9-1/2 HHCS GRADE 5, ZP	2
3	2520-506	3/4-10 HEX NUT, GR 8, ZP	2
4	2525-501	3/4 MED LOCKWASHER ZP	4

ISO-10000-011

OPERATION INSTRUCTIONS

TOOLBAR FRAME HEIGHT ADJUSTMENT

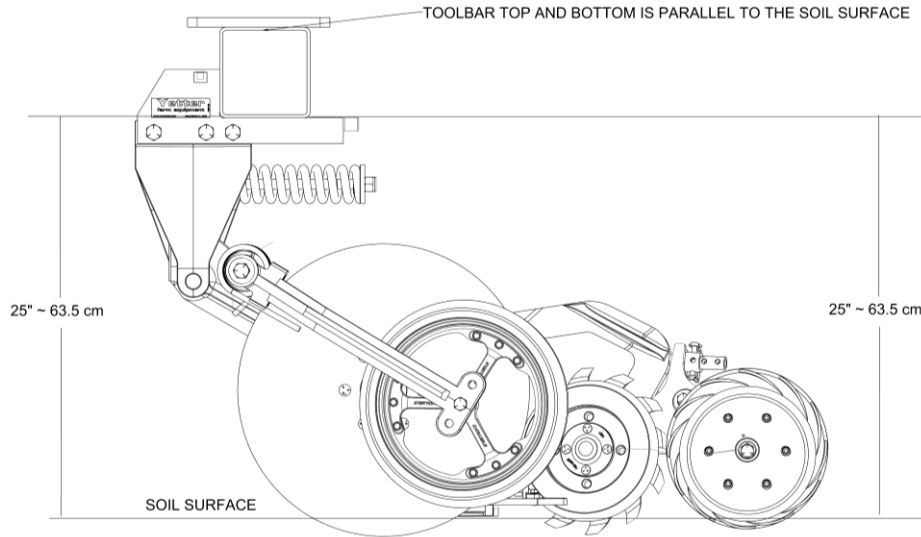

FIGURE A (CORRECT)

Adjusting Opener Depth:
-Raise toolbar frame for shallow application
-Lower toolbar frame for deeper application

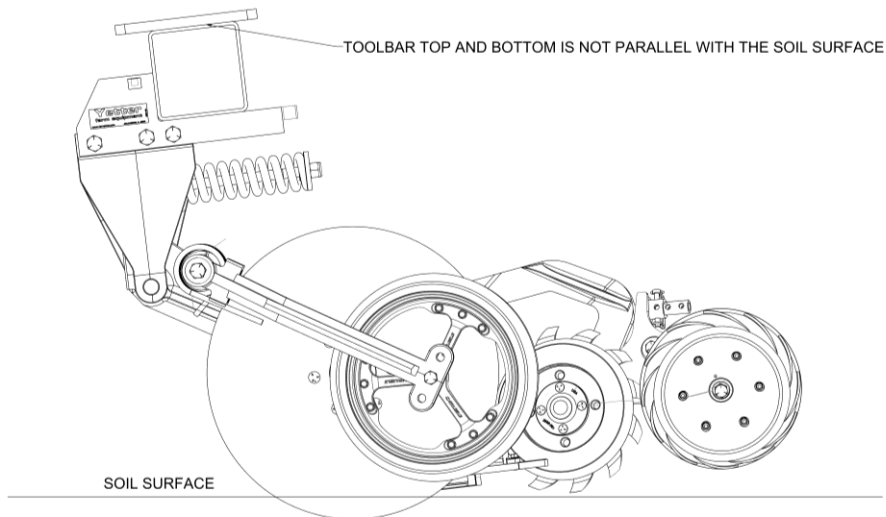

FIGURE B (INCORRECT)

Figure A: The toolbar height is set to 25" above the soil surface. To ensure that frame heights are correct, it is important measurements are taken before use.

Figure B: The hitch is set too low while the toolbar is not parallel with the soil surface.

Note: The illustrations are intended to show that the settings are critical. **Tool frame levelness and height adjustment are very important settings for correct performance of the 10000 Magnum™ Coulters**

OPERATION INSTRUCTIONS

10000 MAGNUM™ CLOSING WHEEL DOWNFORCE ADJUSTMENT

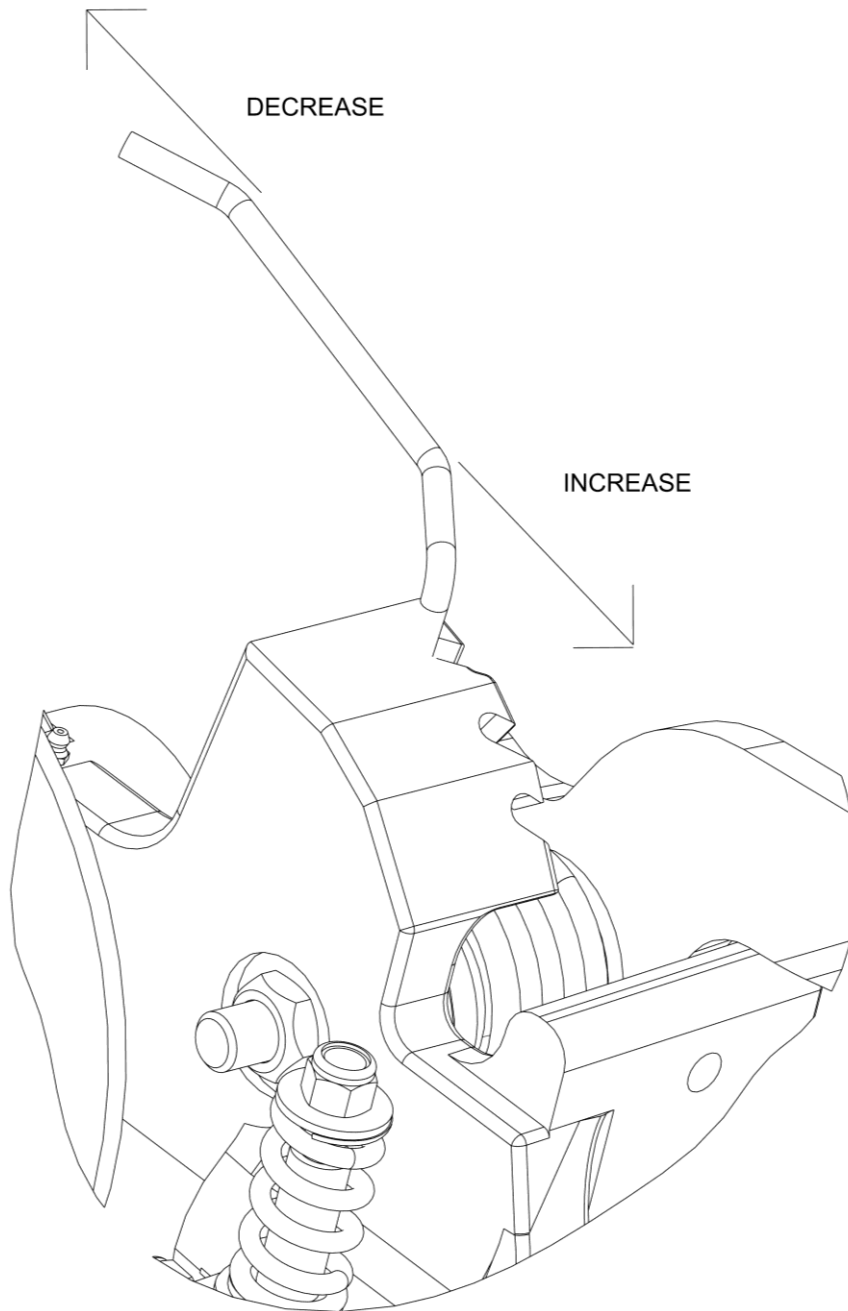

OPERATION INSTRUCTIONS

10000 MAGNUM™ WHEEL SEALER DEPTH ADJUSTMENT

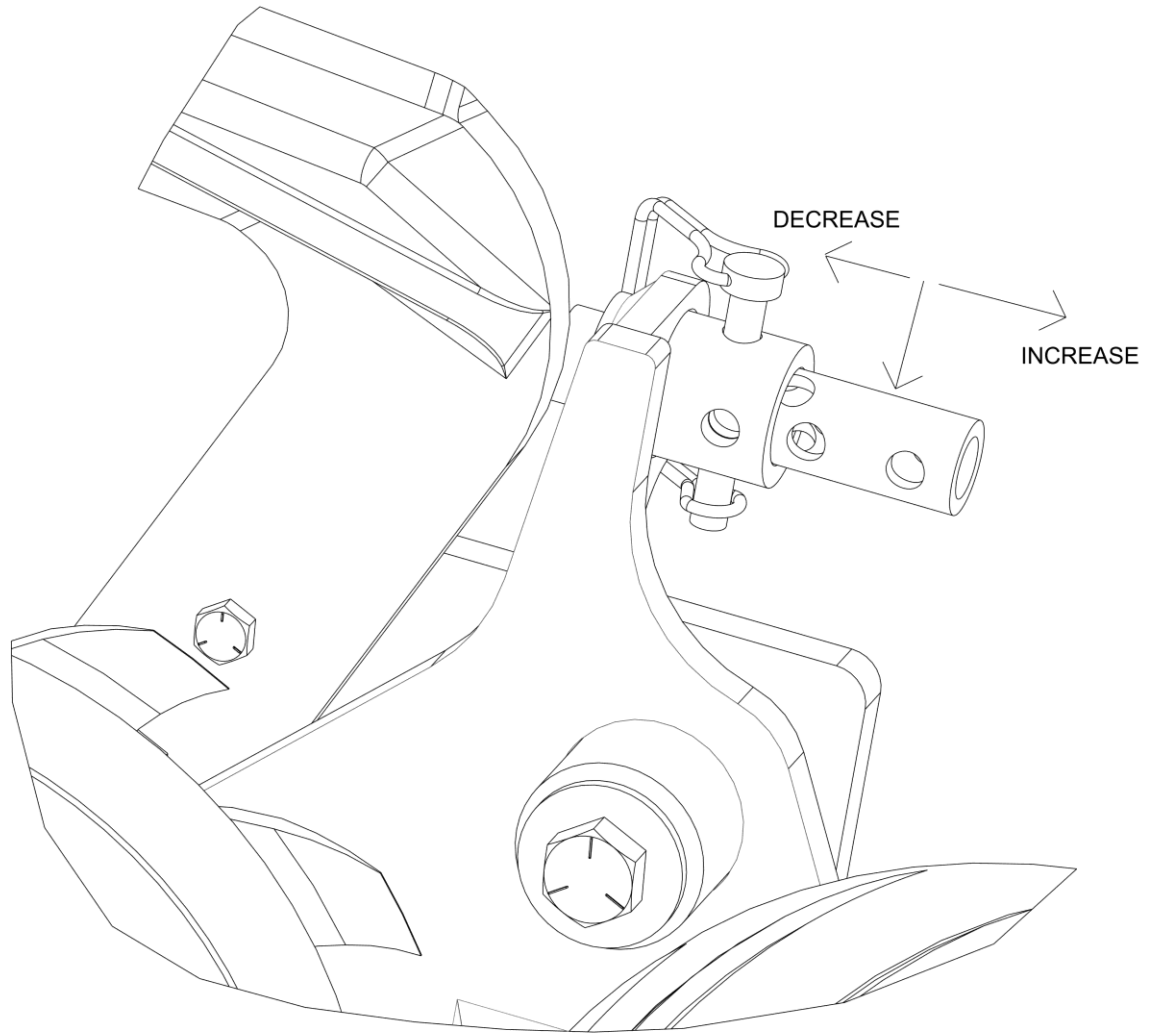

OPERATION INSTRUCTIONS

Troubleshooting the 10000 Series Magnum™ Coultter

Symptom	Problem	Solution
Mud builds up on press wheels and wheels stop turning	Too much down pressure	Remove spring pressure from press wheels
	Field is too wet	Wait until field dries before running
Poor opener penetration	Hard ground conditions	Add weights to toolbar frame
	Residue laying in bunches	Spread residue evenly across the field
	Excessive residue	Adjust toolbar for deeper operation
	Dull disk openers	Sharpen or replace opener disks
Furrow not closing	Disk opener worn too small	Replace disk opener
	Field is too wet or overly hard ground conditions	Adjust closing wheel spring pressure
Soil freezes to blade		Raise toolbar when stopping to prevent anhydrous ammonia from contacting and freezing soil to blade
Residue buildup in front of openers	Residue wedged between scraper and disk opener	Verify adjustment bolt is properly adjusted to hold scraper against blade
Uneven depth	Residue laying in bunches	Spread residue evenly across field
	In adequate down pressure	Increase down pressure or install weights

MAINTENANCE

Practice Safety

Understand and practice safe service procedures before doing work. Follow ALL the operating, maintenance, and safety information in the equipment operator's manual. Clear the area of bystanders, especially small children, when performing any maintenance or adjustments. Keep work area clean and dry. Use adequate lighting for the job. Use only tools, jacks, and hoists of sufficient capacity for the job.

Never lubricate, service, or adjust a machine while it is moving. Keep hands, feet, and clothing free from power-driven moving parts. Disengage all power and operate controls to relieve pressure. Lower equipment to the ground and stop the engine. Remove the key. Wait for all moving parts to stop before servicing, adjusting, repairing, or unplugging.

Securely support any machine elements with blocks or safety stands that must be raised for service work.

Keep all parts in good condition and properly installed. Fix damaged equipment immediately. Replace worn or broken parts. Remove any buildup of grease, oil, or debris from the equipment.

Make sure all guards are in place and properly secured when maintenance work is completed.

MAINTENANCE

Lubrication Intervals

Lubricate with grease at hourly interval indicated on symbol.

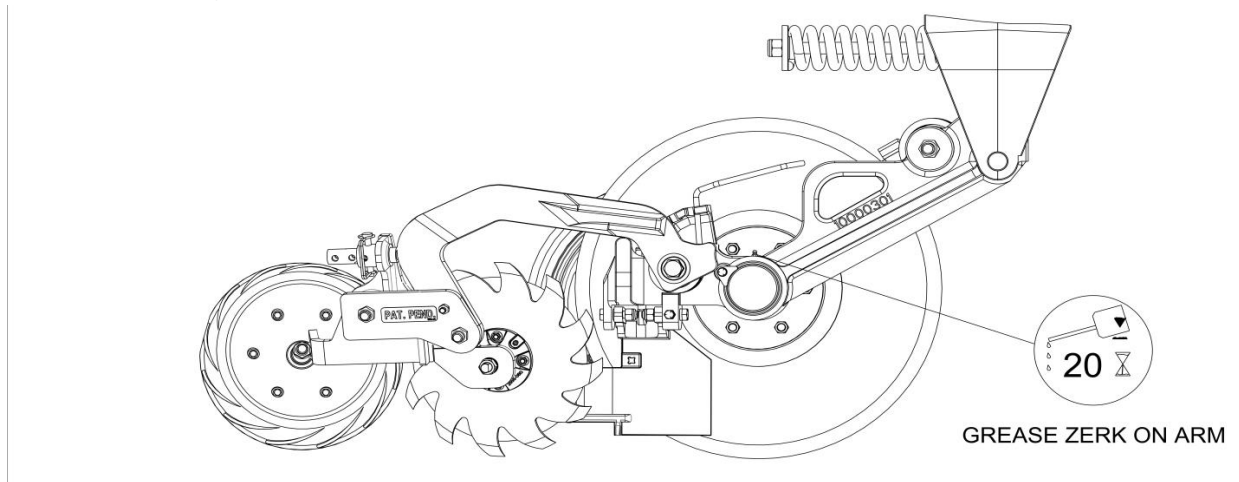

IMPORTANT: The recommended service intervals are based on normal operating conditions. Severe or unusual conditions may require more frequent lubrication.

Perform each lubrication and service procedure at the beginning of each season. Clean grease fittings before using grease gun to avoid injecting dirt and grit into the bearing. Replace and lost or broken fittings immediately. If a fitting fails to take grease, remove and clean thoroughly, replace if necessary. Also check for failure of adjoining parts.

MAINTENANCE

Lubrication



CAUTION: To help prevent serious injury or death to you or others, service machinery on a level surface. Lower machine to ground or sufficiently lock or block raised machine before servicing. If machine is connected to tractor, engage parking brake and place transmission in “PARK”, shut off engine and remove key. If machine is detached from tractor, block wheels and use jack stands to prevent movement.



CAUTION: Do not clean, lubricate, or adjust machine while in motion.

Use grease based on NLGI consistency number and the expected air temperature range during operation.

Use a **multi-purpose polyurea, water resistant, moderate speed, and NLGI grade #2** grease. Other greases may be used if they meet the **NLGI performance standard**.

IMPORTANT: Some types of grease thickener are not compatible with others. Consult your grease supplier before mixing different types of grease.

Alternative Lubricants

Conditions in certain geographical areas may require special lubricants and lubrication practices which do not appear in the operator’s manual. If there are any questions, consult Yetter Manufacturing Co. to obtain the latest information and recommendations.

Part #	Description	Ounces of Grease
10000-111-LH 10000-111-RH	Main Arm, Magnum Assembly	18 oz

Storing Lubricants

Your machine can operate at top efficiency only if clean lubricants are used.

Use clean containers to handle all lubricants.

Store them in an area protected from dust, moisture, and other contaminants.

MAINTENANCE

Storing the Equipment

Store the machine in an area away from human activity.

Store the machine in a RAISED position.

Install service locks on all wheel cylinders.

At the end of the season the machine should be thoroughly inspected and prepared for storage. Repair or replace any worn or damaged components to prevent down time at the beginning of the following season. Store machine under cover with all parts in operating condition.

- Clean machine thoroughly to remove all dirt, debris, and crop residue.
- Inspect machine for worn or broken parts. See your Yetter Farm Equipment dealer during the off-season so parts and service can be acquired when the machine is not needed in the field.
- Lubricate bearings as outlined in the lubrication section.
- Paint all parts which are chipped or worn to prevent rust.
- Store machine in a clean, dry location with the unit out of the sun.
- If the machine cannot be stored inside, cover with a waterproof tarpaulin and tie securely in place
- Do not allow children to play on or around the machine

MAINTENANCE

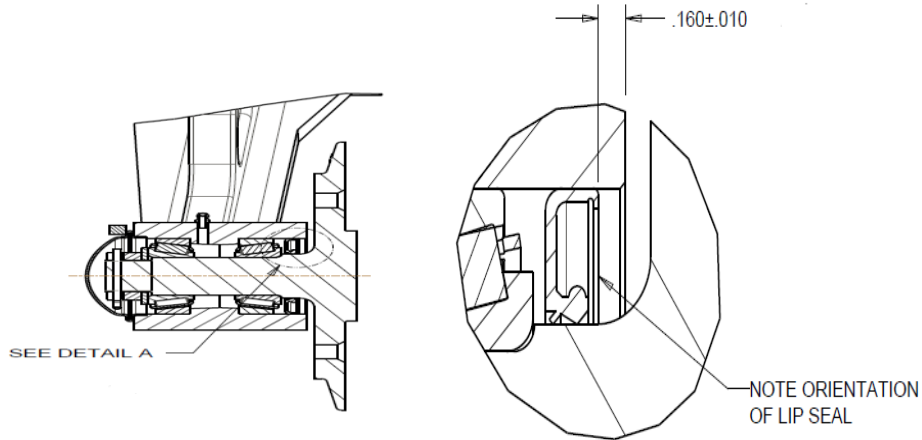

BEARING ADJUSTMENT:

1. Raise the toolbar until the blade is clear of the ground. Place a safety stand under the toolbar. Remove the blade. Remove the hub cap, cotter pin, slotted nut, washer and spacer from the spindle shaft assembly.
2. Pull the coulter spindle shaft assembly from the hub. Remove bearing cones and seal.
3. Wash the old grease from the hub, bearing cups, coulter spindle shaft, seal and bearing cones. Inspect the condition of bearing cups, cones and seal. Replace if necessary.
4. Apply #2 multi-purpose **polyurea** grease on each bearing. Make sure the space around each roller is filled. Lubricate the bearing cups.
5. Position the bearing in the cup and install the seal. Lubricate the seal lips and proceed with re-assembly of the removed parts including the blade. Blade bolt torque is 90 - 96 ft/lbs.
6. While rotating the spindle, tighten/torque the slotted nut to 15-20 ft/lbs. to pre-load the bearings. Loosen the slotted nut ½ turn to release the pre-load.
7. While rotating the spindle, tighten the slotted nut until the next castellation opening on the nut is aligned with a hole in the spindle. Install the cotter pin and bend the ends of the pin around the nut.
8. Check the spindle rotation, if the spindle rotates freely then install hub cap, retainer, bolt and lock washer. If the spindle is difficult to turn and/or roughness is felt then replace the bearings and cups as required.

KNIFE WEAR:

The lower portion of the scraper and tube are subject to wear during operation. The rate of wear will depend on a variety of factors and in abrasive hard soil conditions the wear will be more rapid.

NOTE: In certain areas, replacement knives should be kept in stock, replacing worn knives as needed.

ADJUST KNIFE TO BLADE CONTACT on each opener so the blade will turn by hand with slight resistance, but will not coast or freewheel. In loose soil the knife adjustment is critical. If adjustment is not maintained, soil or residue may wedge between knife and blade, resulting in the blade not turning. Because of blade run out, rotate the blade one full revolution after adjustment. Re-adjust knife as needed. Never strike the knife with a heavy object or damage may occur. To adjust, use shims or adjust knife mounting out.

PART IDENTIFICATION
10000-001-LH (SHOWN) & 10000-001-RH
MAGNUM w/ WALKING TANDEM
4,5,6, AND 7 WIDE TOOLBARS

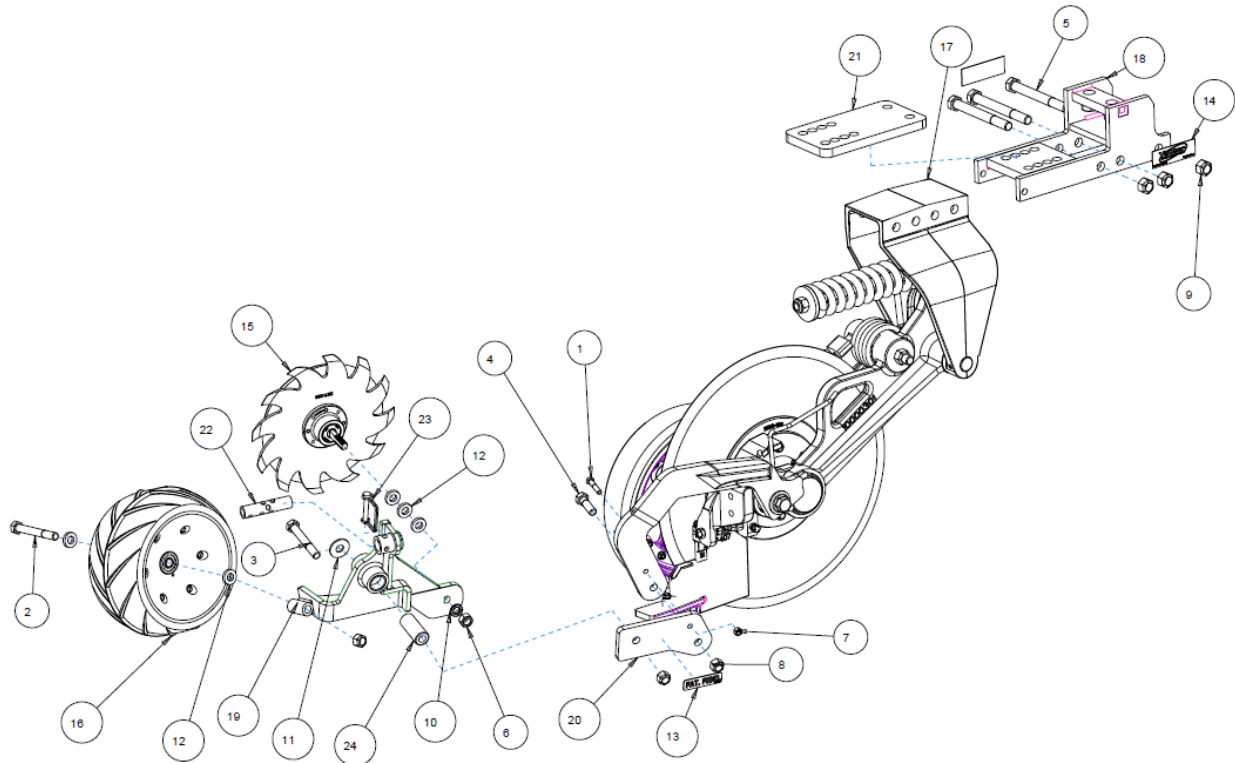

NOTE A: LH PARTS ARE DENOTED BY AN "L" OR "LH" SUFFIX ON PART NUMBER RH PIECES HAVE THE SAME NUMBER WITH "R" OR "RH" AS A SUFFIX

ITEM	PART NO.	DESCRIPTION	QTY
1	2502-245	3/8-16 X 1-3/4 HHCS GR 5 ZP	1
2	2502-327	5/8-11 X 5 HHCS GR.5 ZP	1
3	2502-334	5/8-11 X 4-1/2 HHCS GR5 ZP	1
4	2502-391	5/8-11 X 2 HHCS GR 5 ZP	1
5	2502-509	3/4-10 X 7 HHCS GR.5 ZP	3
6	2520-452	5/8-11 HEX NUT GR 8 ZP	1
7	2520-601	3/8-16 HEX TOP LOCK, GR. C, ZP	1
8	2520-603	5/8-11 HEX TOP LOCK, GR. C, ZP	3
9	2520-604	3/4-10 HEX TOP LOCK, GR. C, ZP	3
10	2525-451	5/8 MED. LOCKWASHER ZP.	1
11	2526-451	5/8 STD FLATWASHER ZP	1
12	2526-455	WASH 21/32" X 1 1/4" X 1/4	5
13	2565-071	PATENT PENDING DECAL	1
14	2565-162	YETTER DECAL, 1-1/2 X 4-1/2	2
15	2987-142-L	LH CAST CLOSER ASS'Y W/ST	1
16	6200-363	6.5 X 12 PRESS	1
17	10000-100-LH	MAGNUM L.H. BASE ASSY	1
18	10000-200	BAR MOUNT 4,5,6,7 WIDE	1
19	10000-205-LH	TANDEM LH CLOSER W.A.	1
20	10000-308	TANDEM MOUNT PLATE	1
21	10000-310	CLAMP PLATE UNIVERSAL	1
22	10000-330	STANDARD ADJUSTMENT TUBE	1
23	10000-334	3/8" WIRE PIN	1
24	10000-361	SEALER PIVOT BUSHING	1

PART IDENTIFICATION

10000-002-LH (SHOWN) & 10000-002-RH
MAGNUM w/ WALKING TANDEM
4" WIDE TOOLBAR, SHORT MOUNT

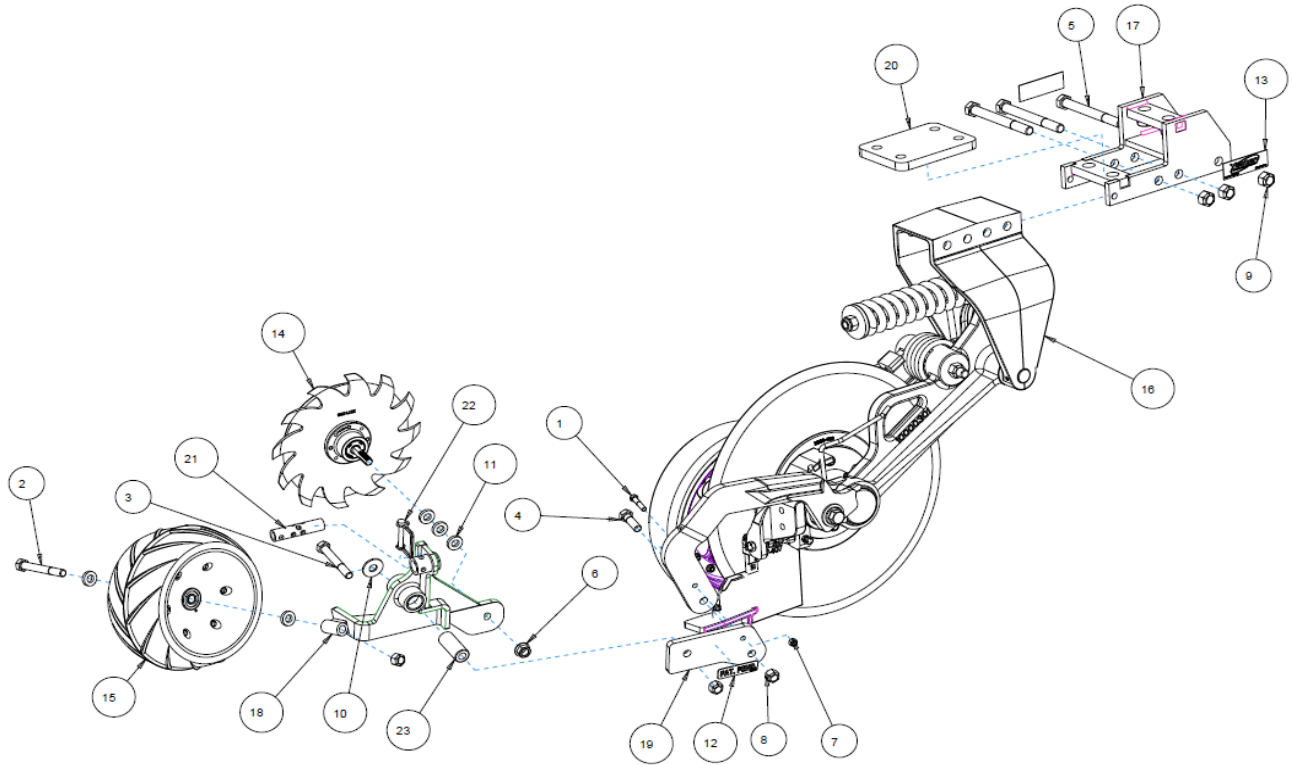

NOTE A: LH PARTS ARE DENOTED BY AN "L" OR "LH" SUFFIX ON PART NUMBER
RH PIECES HAVE THE SAME NUMBER WITH "R" OR "RH" AS A SUFFIX

ITEM	PART NO.	DESCRIPTION	QTY
1	2502-245	3/8-16 X 1-3/4 HHCS GR 5 ZP	1
2	2502-327	5/8-11 X 5 HHCS GR.5 ZP	1
3	2502-334	5/8-11 X 4-1/2 HHCS GR5 ZP	1
4	2502-391	5/8-11 X 2 HHCS GR 5 ZP	1
5	2502-509	3/4-10 X 7 HHCS GR.5 ZP	3
6	2520-465	5/8-11 SER. FLANGE NUT, GR 8, ZP	1
7	2520-601	3/8-16 HEX TOP LOCK, GR. C, ZP	1
8	2520-603	5/8-11 HEX TOP LOCK, GR. C, ZP	3
9	2520-604	3/4-10 HEX TOP LOCK, GR. C, ZP	3
10	2526-451	5/8 STD FLATWASHER ZP	1
11	2526-455	WASH 21/32" X 1 1/4" X 1/4	5
12	2565-071	PATENT PENDING DECAL	1
13	2565-162	YETTER DECAL, 1-1/2 X 4-1/2	2
14	2987-142-L	LH CAST CLOSER ASS'Y W/ST	1
15	6200-363	6.5 X 12 PRESS	1
16	10000-100-LH	MAGNUM L.H. BASE ASSY	1
17	10000-201	4" MOUNT	1
18	10000-205-LH	TANDEM LH CLOSER W.A.	1
19	10000-308	TANDEM MOUNT PLATE	1
20	10000-311	CLAMP PLATE 4" BAR	1
21	10000-330	STANDARD ADJUSTMENT TUBE	1
22	10000-334	3/8" WIRE PIN	1
23	10000-361	SEALER PIVOT BUSHING	1

PART IDENTIFICATION

10000-003-LH (SHOWN) & 10000-003-RH MAGNUM w/o WALKING TANDEM. 4". 5". 6". 7" WIDE TOOLBARS

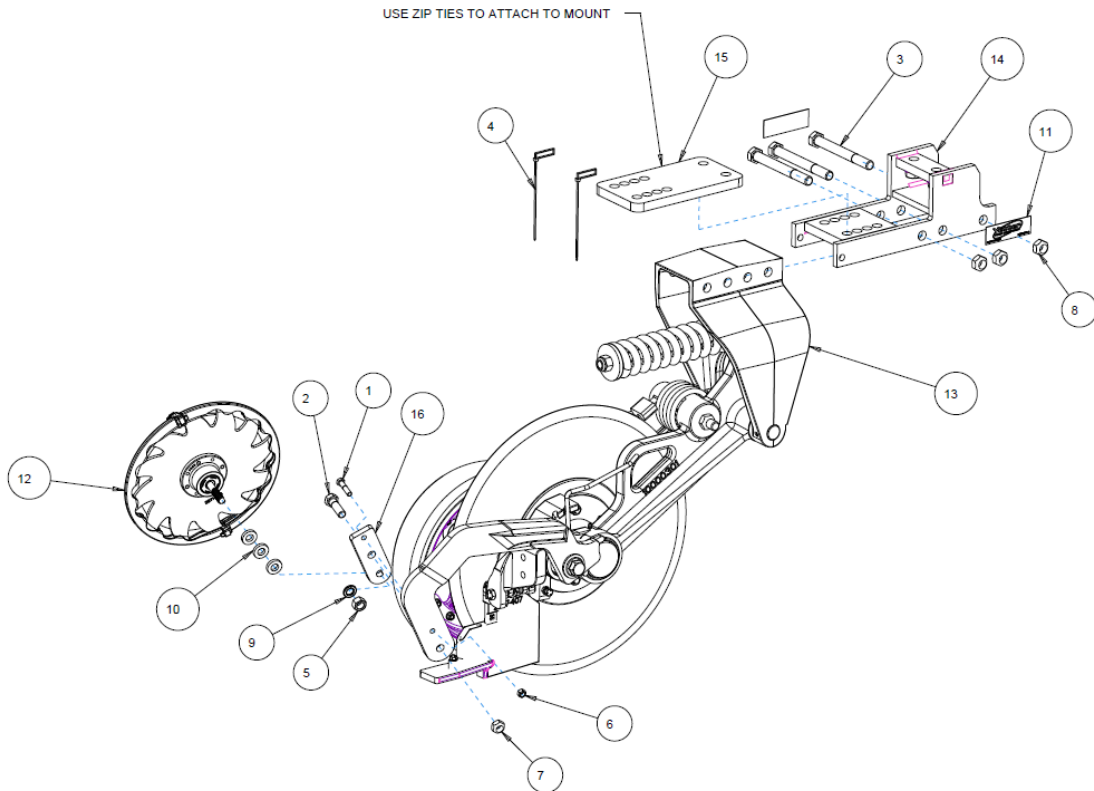

NOTE A: LH PARTS ARE DENOTED
BY AN "L" OR "LH"
SUFFIX ON PART NUMBER
RH PIECES HAVE THE SAME
NUMBER WITH "R" OR "RH" AS A
SUFFIX

ITEM	PART #	DESCRIPTION	QTY
1	2502-245	3/8-16 X 1-3/4 HHCS GR 5 ZP	1
2	2502-391	5/8-11 X 2 HHCS GR 5 ZP	1
3	2502-509	3/4-10 X 7 HHCS GR.5 ZP	3
4	2520-452	5/8-11 HEXNUT ZP	1
5	2520-601	3/8-16 HEX TOP LOCK	1
6	2520-603	5/8-11 HEX TOP LOCK	1
7	2520-604	3/4-10 HEX TOP LOCK	3
8	2525-451	5/8 MED. LOCKWASHER ZP.	1
9	2526-455	WASH 21/32" X 1 1/4" X 1/4	3
10	2565-162	YETTER DECAL, 1-1/2 X 4-1/2	2
11	2987-142-L	LH CAST CLOSER ASS'Y W/ST	1
12	10000-100-LH	MAGNUM L.H. BASE ASSY	1
13	10000-200	BAR MOUNT 4,5,6,7 WIDE	1
14	10000-310	CLAMP PLATE UNIVERSAL	1
15	10000-312	STANDARD CLOSER MOUNT PLATE	1

PART IDENTIFICATION
10000-004-LH (SHOWN) & 10000-004-RH
MAGNUM w/o WALKING TANDEM, 4" WIDE TOOLBARS, SHORT MOUNT

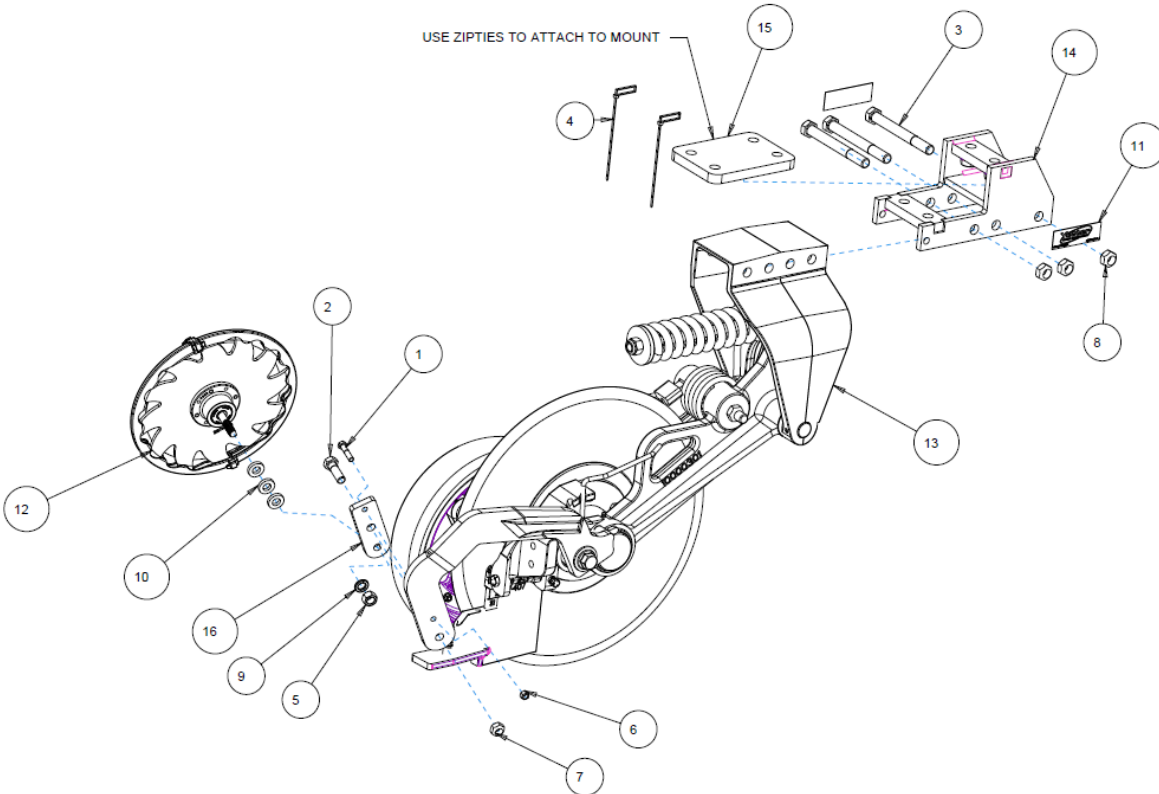

**NOTE A: LH PARTS ARE DENOTED BY AN "L" OR "LH" SUFFIX ON PART NUMBER
 RH PIECES HAVE THE SAME NUMBER WITH "R" OR "RH" AS A SUFFIX**

ITEM	PART NO.	DESCRIPTION	QTY
1	2502-245	3/8-16 X 1-3/4 HHCS GR 5 ZP	1
2	2502-391	5/8-11 X 2 HHCS GR 5 ZP	1
3	2502-509	3/4-10 X 7 HHCS GR.5 ZP	3
4	2515-552	CABLE TIE, .15 X 8.5, BLACK	2
5	2520-452	5/8-11 HEX NUT GR 8 ZP	1
6	2520-601	3/8-16 HEX TOP LOCK, GR. C, ZP	1
7	2520-603	5/8-11 HEX TOP LOCK	1
8	2520-604	3/4-10 HEX TOP LOCK	3
9	2525-451	5/8 MED. LOCKWASHER ZP.	1
10	2526-455	WASH 21/32" X 1 1/4" X 1/4	3
11	2565-162	YETTER DECAL	2
12	2987-142-L	LH CAST CLOSER ASS'Y W/ST	1
13	10000-100-LH	MAGNUM L.H. BASE ASSY	1
14	10000-201	4" MOUNT	1
15	10000-311	CLAMP PLATE 4" BAR	1
16	10000-312	STANDARD CLOSER MOUNT PLATE	1

PART IDENTIFICATION
 10000-099
 2" DROP DOWN KIT

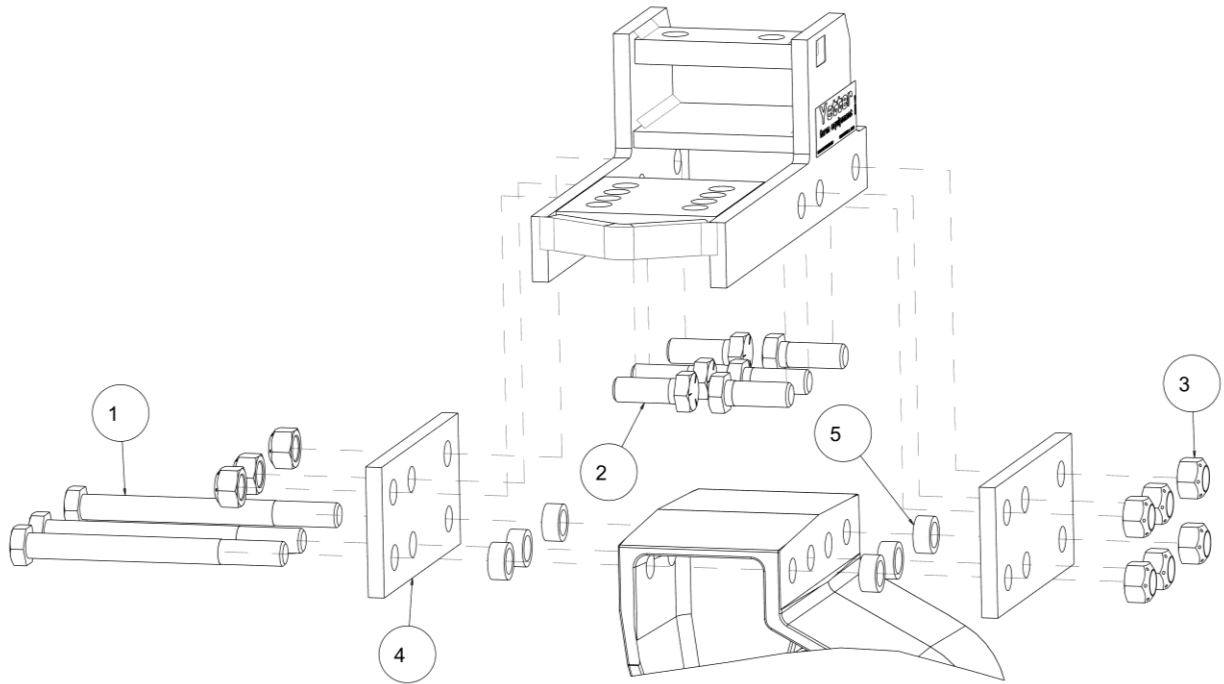

DROP DOWN KIT TO BE USED IN WHEEL TRACKS

ITEM	PART #	DESCRIPTION	QTY
1	2502-405	3/4-10 X 8 HHCS GR. 5 ZP	3
2	2502-503	3/4-10 X 2 HHCS GR.5 ZP	6
3	2520-604	3/4-10 HEX TOP LOCK, GR. C, ZP	9
4	10000-348	DROP-DOWN PLATE	2
5	10000-349	BUSHING	6

PART IDENTIFICATION
10000-100-LH (SHOWN) & 10000-1000-RH
MAGNUM BASE ASSEMBLY

ITEM	PART #	DESCRIPTION	QTY
1	2502-198	5/16-18 X 1 HHCS GR.5 ZP	1
2	2502-244	3/8-16 X 1-1/4 HHCS GR 5 ZP	1
3	2502-296	1/2-13 X 2-1/2 HHCS GR5 ZP	1
4	2502-327	5/8-11 X 5 HHCS GR.5 ZP	1
5	2502-351	1/2-13 X 2 HHCS GR.5 ZP	1
6	2502-364	1/2-13 X 4 HHCS GR. 5 ZP	1
7	2502-405	3/4-10 X 8 HHCS GR. 5 ZP	1
8	2502-426	3/4-10 X 6 HHFS GR8, ZP	1
9	2502-525	3/4-10 X 16 HHCS GR. 5 ZP, 3" THREAD LENGTH	1
10	2506-306	1/2-13 X 1-1/2 #3 REPAIRPLWBLT	6
11	2520-253	3/8-16 JAM HEX NUT ZP	1
12	2520-357	1/2-13 LOCK HEX NUT, GR A, ZP	6
13	2520-363	1/2-13 NYL INSERT LOCKNUT, GR 2	4
14	2520-516	3/4-10NYLON INSERT LCKNT, GR 2, ZP	1
15	2520-603	5/8-11 HEX TOP LOCK	1
16	2520-604	3/4-10 HEX TOP LOCK	2
17	2525-201	5/16 MED. LOCKWASHER ZP.	1
18	2526-351	1/2 STANDARD FLATWASHER ZP	2
19	2526-453	5/8 SAE FLATWASHER ZP	3
20	2526-501	3/4 STANDARD FLATWASHER ZP	2
21	2530-208	3/8 X 2-1/2 ROLL PIN ZP	1
22	2570-069	40MM BEARING - AN212132 (5203KYY2)	1
23	2570-447	EYEBOLT, 1/2-13 X 4-1/4	1
24	2571-279	.256 X 22.60" COULTER BLADE	1
25	2967-302	SPACER, 3/4" PLATED	1
26	2986-342	COMPRESSION SPRING, AVENGER	1
27	2986-405	SPRING BUSHING	1
(A) 28	2987-395-L	PAINTED LH CLSNG ARM TORS SPRG	1
29	2987-407	LH SIDE KNIFE CAST, MACH W/CARB	1
30	3000-344	2-1/2" SPRING#LHL-1500B-2, BLK	1
(A) 31	10000-111-LH	MAGNUM LH MAIN ARM, ASSEMBLY	1
32	10000-112	WW ARM W/ BUSHING, ASSY	1
(A) 33	10000-113-LH	CLOSING ARM LH W/ BUSHING	1
34	10000-114	WIPER WHEEL	1
35	10000-203	CLOSING PIVOT BUSHING	1
(A) 36	10000-250-LH	BEAVERTAIL LH W.A., 2IN	1
37	10000-302	MOUNT OFFEST MAGNUM, MACHINED	1
38	10000-307	MAIN PIVOT PIN	1
39	10000-309	BUSHING, WIPER WHEEL PIVOT	1
(A) 40	10000-317-LH	MAGNUM WIPER WHEEL TORSION SPRING, LH	1
41	10000-333	SPRING LIMITER BUSHING	1
42	10000-347	PIVOT BUSHING	3

MANUFACTURED 7/2016 – 2/2018

PART IDENTIFICATION
10000-100-LH (SHOWN) & 10000-1000-RH
MAGNUM BASE ASSEMBLY

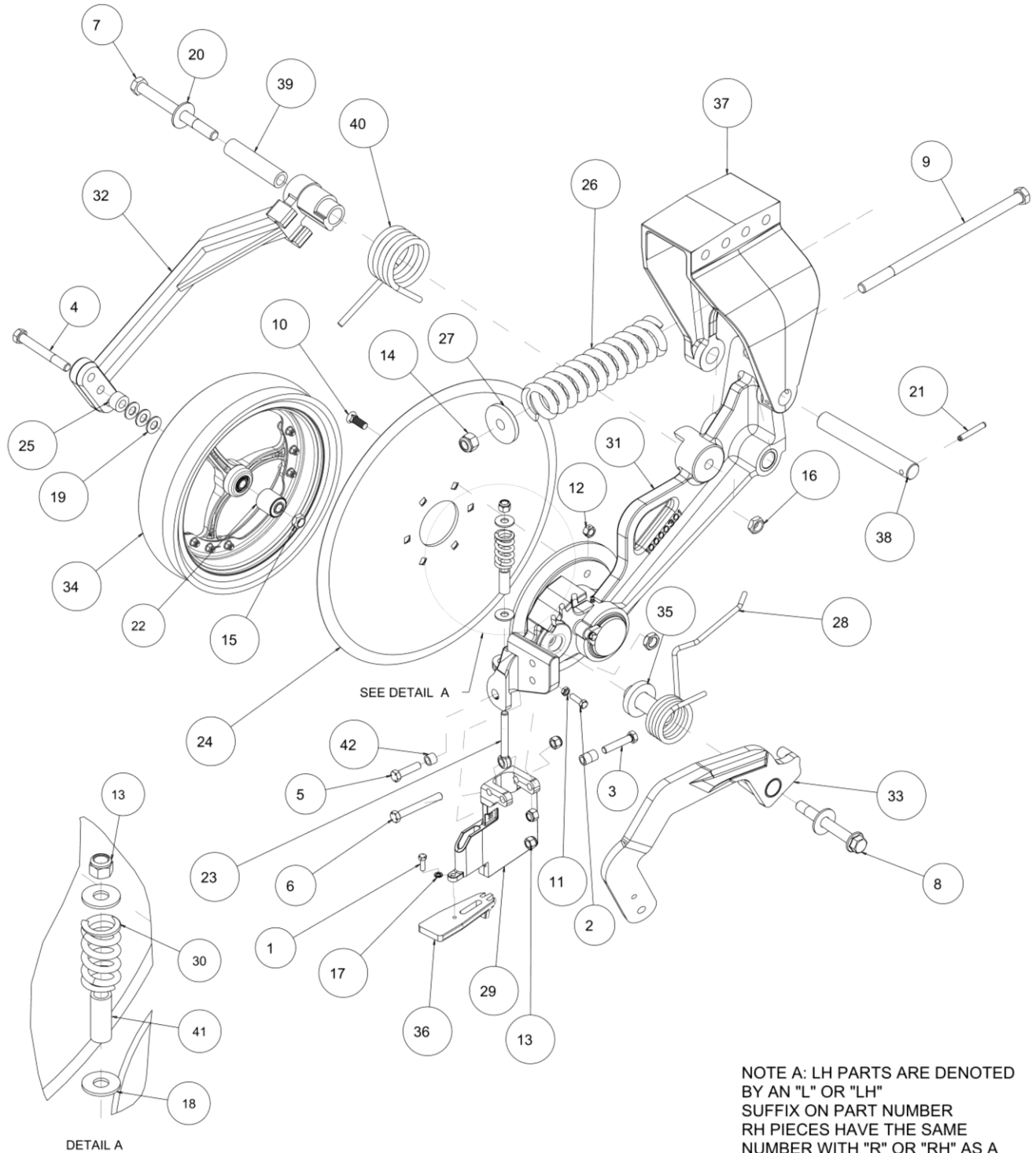

MANUFACTURED 7/2016 – 2/2018

PART IDENTIFICATION 10000-100-LH

ITEM	PART NO.	DESCRIPTION	QTY
1	2502-202	5/16-18 X 1 1/4 HHCS GR.5 ZP	1
2	2502-244	3/8-16 X 1-1/4 HHCS GR 5 ZP	1
3	2502-296	1/2-13 X 2-1/2 HHCS GR5 ZP	1
4	2502-327	5/8-11 X 5 HHCS GR.5 ZP	1
5	2502-351	1/2-13 X 2 HHCS GR.5 ZP	1
6	2502-405	3/4-10 X 8 HHCS GR. 5 ZP	1
7	2502-426	3/4-10 X 6 HHFS GR8, ZP	1
8	2502-525	3/4-10 X 16 HHCS GR. 5 ZP, 3' THREAD LENGTH	1
9	2506-306	1/2-13 X 1-1/2 #3 REPAIRPLWBLT	6
10	2520-253	3/8-16 JAM HEX NUT ZP	1
11	2520-357	1/2-13 LOCK HEX NUT, GR A, ZP	6
12	2520-363	1/2-13 NYL INSERT LOCKNUT, GR 2	3
13	2520-516	3/4-10 NYLON INSERT LCKNT, GR 2, ZP	1
14	2520-603	5/8-11 HEX TOP LOCK, GR. C, ZP	1
15	2520-604	3/4-10 HEX TOP LOCK, GR. C, ZP	2
16	2525-201	5/16 MED. LOCKWASHER ZP.	1
17	2526-351	1/2 STANDARD FLATWASHER ZP	2
18	2526-352	1/2 SAE FLATWASHER ZP	1
19	2526-453	5/8 SAE FLATWASHER	3
20	2526-501	3/4 STANDARD FLATWASHER ZP	2
21	2530-208	3/8 X 2-1/2 ROLL PIN ZP	1
22	2531-107	1/8 X 1 COTTER PIN ZP	1
23	2570-447	EYEBOLT, 1/2-13 X 4-1/4, ZP	1
24	2571-279	.256 X 22.60' COULTER BLADE	1
25	2967-302	SPACER, 3/4" PLATED	1
26	2986-342	COMPRESSION SPRING, AVENGER	1
27	2986-405	SPRING BUSHING	1
28	2987-395-L	PAINTED LH CLSNG ARM TORS SPRG	1
29	2987-407	LH SIDE KNIFE MACHINED W/ CARBIDE	1
30	3000-344	2-1/2" SPRING#LHL-1500B-2, BLK	1
31	10000-111-LH	MAGNUM LH MAIN ARM, ASSEMBLY	1
32	10000-112	WW ARM W/ BUSHING, ASSY	1
33	10000-113-LH	CLOSING ARM LH W/ BUSHING	1
34	10000-114	WIPER WHEEL	1
35	10000-203	CLOSING PIVOT BUSHING	1
36	10000-250-LH	BEAVERTAIL LH W.A., 2IN	1
37	10000-302	MOUNT OFFEST MAGNUM, MACHINED	1
38	10000-307	MAIN PIVOT PIN	1
39	10000-309	BUSHING, WIPER WHEEL PIVOT	1
40	10000-317-LH	MAGNUM WIPER WHEEL TORSION SPRING, LH	1
41	10000-333	SPRING LIMITER BUSHING	1
42	10000-347	PIVOT BUSHING	3
43	10000-355	CLEVIS PIN, 0.500 X 3.5, ZP	1

MANUFACTURED 3/2018 - PRESENT

PART IDENTIFICATION

10000-100-LH

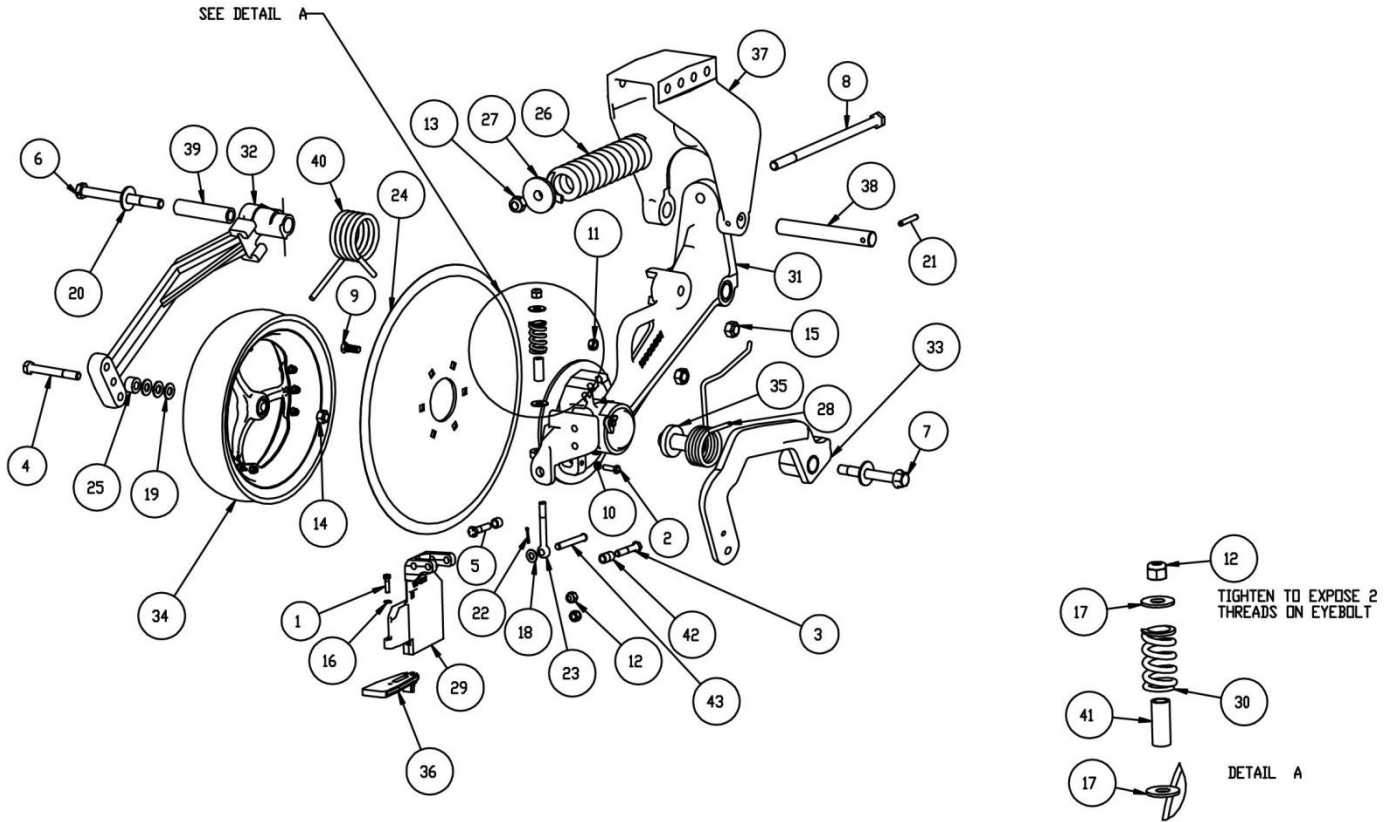

MANUFACTURED 3/2018 - PRESENT

PART IDENTIFICATION 10000-100-RH

ITEM	PART NO.	DESCRIPTION	QTY
1	2502-202	5/16-18 X 1 1/4 HHCS GR.5 ZP	1
2	2502-244	3/8-16 X 1-1/4 HHCS GR 5 ZP	1
3	2502-296	1/2-13 X 2-1/2 HHCS GR5 ZP	1
4	2502-327	5/8-11 X 5 HHCS GR.5 ZP	1
5	2502-351	1/2-13 X 2 HHCS GR.5 ZP	1
6	2502-405	3/4-10 X 8 HHCS GR. 5 ZP	1
7	2502-426	3/4-10 X 6 HHFS GR8, ZP	1
8	2502-525	3/4-10 X 16 HHCS GR. 5 ZP, 3" THREAD LENGTH	1
9	2506-306	1/2-13 X 1-1/2 #3 REPAIRPLWBLT	6
10	2520-253	3/8-16 JAM HEX NUT ZP	1
11	2520-357	1/2-13 LOCK HEX NUT, GR A, ZP	6
12	2520-363	1/2-13 NYL INSERT LOCKNUT, GR 2	3
13	2520-516	3/4-10 NYLON INSERT LCKNT, GR 2, ZP	1
14	2520-603	5/8-11 HEX TOP LOCK, GR. C, ZP	1
15	2520-604	3/4-10 HEX TOP LOCK, GR. C, ZP	2
16	2525-201	5/16 MED. LOCKWASHER ZP.	1
17	2526-351	1/2 STANDARD FLATWASHER ZP	2
18	2526-352	1/2 SAE FLATWASHER ZP	1
19	2526-453	5/8 SAE FLATWASHER ZP	3
20	2526-501	3/4 STANDARD FLATWASHER ZP	2
21	2530-208	3/8 X 2-1/2 ROLL PIN ZP	1
22	2531-107	1/8 X 1 COTTER PIN ZP	1
23	2570-447	EYEBOLT, 1/2-13 X 4-1/4, ZP	1
24	2571-279	.256 X 22.60" COULTER BLADE	1
25	2967-302	SPACER, 3/4" PLATED	1
26	2986-342	COMPRESSION SPRING, AVENGER	1
27	2986-405	SPRING BUSHING	1
28	2987-395-R	PAINTED RH CLOSING ARM TORSION SPRING	1
29	2987-406	RH SIDE KNIFE CAST, MACHINE W/ CARBIDE	1
30	3000-344	2-1/2" SPRING#LHL-1500B-2, BLK	1
31	10000-111-RH	MAGNUM RH MAIN ARM ASSEMBLY	1
32	10000-112	WW ARM W/ BUSHING, ASSY	1
33	10000-113-RH	CLOSING ARM RH W/ BUSHING	1
34	10000-114	WIPER WHEEL	1
35	10000-203	CLOSING PIVOT BUSHING	1
36	10000-250-RH	BEAVERTAIL RH W.A., 2IN	1
37	10000-302	MOUNT OFFSET MAGNUM, MACHINED	1
38	10000-307	MAIN PIVOT PIN	1
39	10000-309	BUSHING, WIPER WHEEL PIVOT	1
40	10000-317-RH	MAGNUM WIPER WHEEL TORSION SPRING, RH	1
41	10000-333	SPRING LIMITER BUSHING	1
42	10000-347	PIVOT BUSHING	3
43	10000-355	CLEVIS PIN, 0.500 X 3.5, ZP	1

MANUFACTURED 3/2018 - PRESENT
PART IDENTIFICATION
10000-100-RH

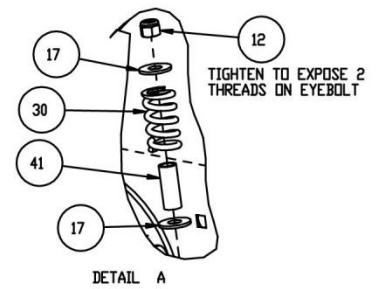
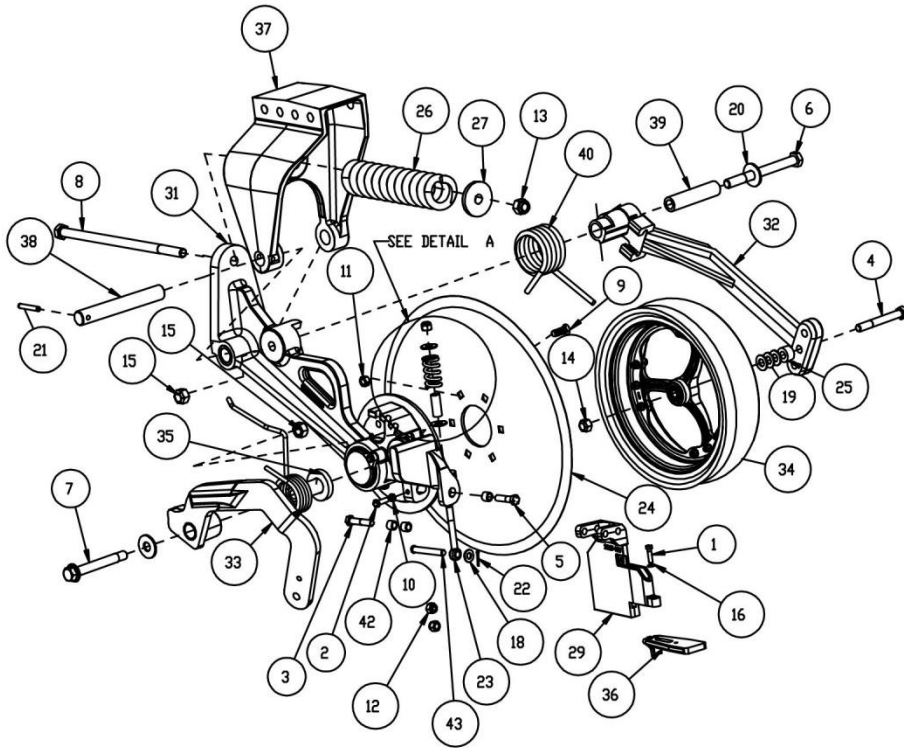

MANUFACTURED 3/2018 - PRESENT

PART IDENTIFICATION
 10000-1111-LH (SHOWN)
 10000-111-RH

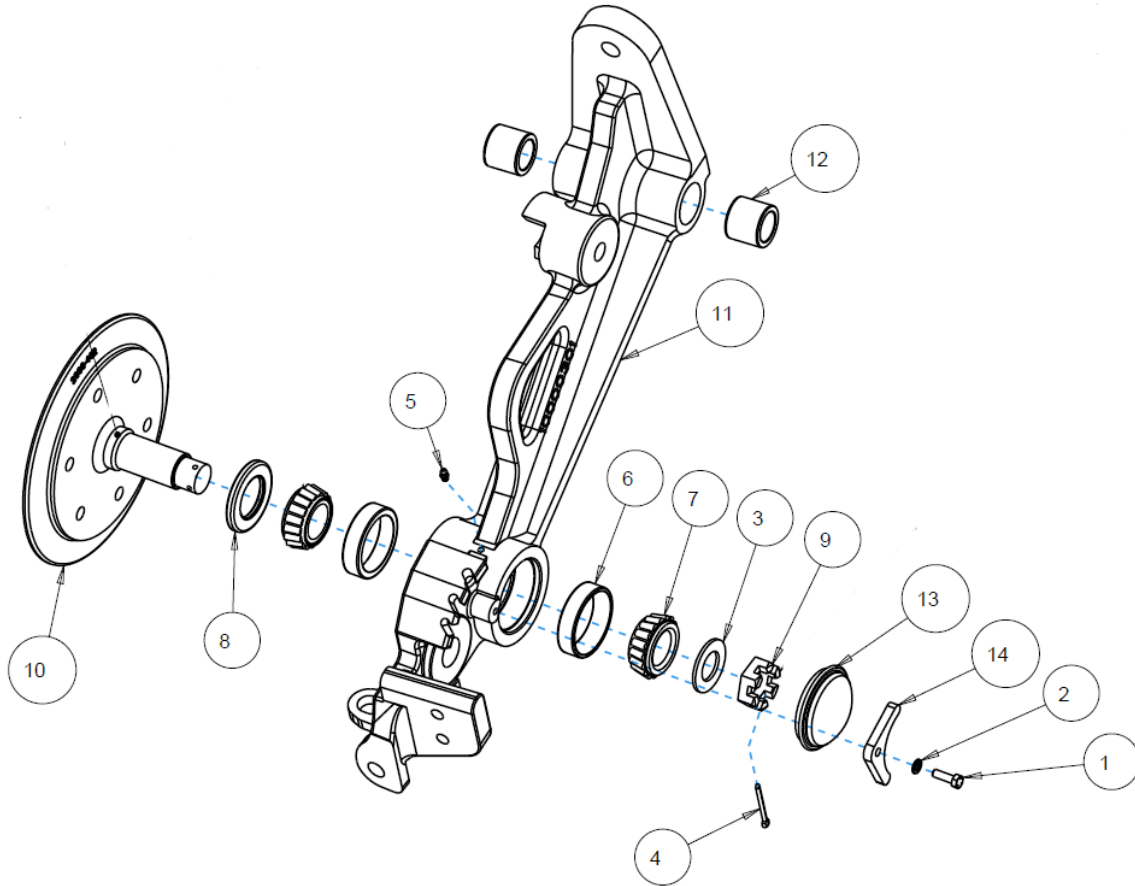

ITEM	PART NO.	DESCRIPTION	QTY
1	2502-198	5/16-18 X 1 HHCS GR.5 ZP	1
2	2525-201	5/16 MED. LOCKWASHER ZP.	1
3	2526-562	1-17/64ID X2-1/4OD X10GA BU	1
4	2531-124	COTTER PINS	1
5	2533-110	1/4-28 ZERK STRAIGHT SELF-TAP	1
6	2550-056	CUP, KOYO #2729	2
7	2550-057	BEARING, KOYO #2788R	2
8	2550-058	SEAL, CR #17699 545165-55	1
9	2986-329	MACH CASTLE NT 1 1/4-12, GR 2, ZP	1
10	2986-402	25" COULTER SPINDLE	1
11	10000-301	MAGNUM ARM MACHINED, L.H.	1
12	10000-313	BEARING SLEEVE 1.75 OD X 1.25 ID X 1.50	2
13	10000-314	HUB CAP	1
14	10000-315	HUB CAP RETAINER	1

PART IDENTIFICATION

10000-112
MAGNUM WHEEL ARM ASSEMBLY

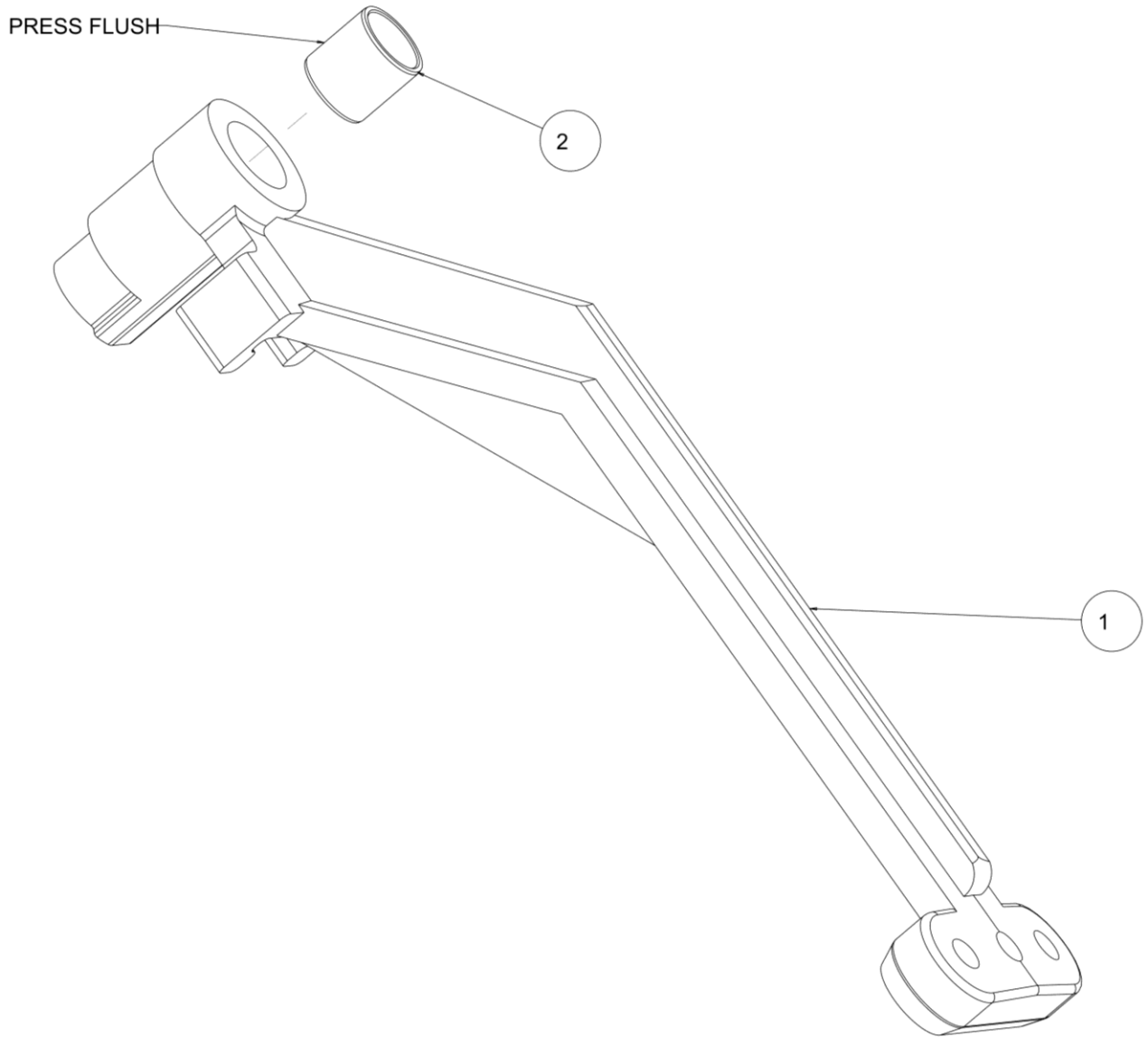

ITEM	PART #	DESCRIPTION	QTY
1	10000-303	WIPER WHEEL ARM, MACHINED	1
2	10000-316	BEARING SLEEVE 1.5 OD X 1.25 ID X 1.50	1

PART IDENTIFICATION

10000-113-LH (SHOWN) & 10000-113-RH
MAGNUM CLOSING ARM

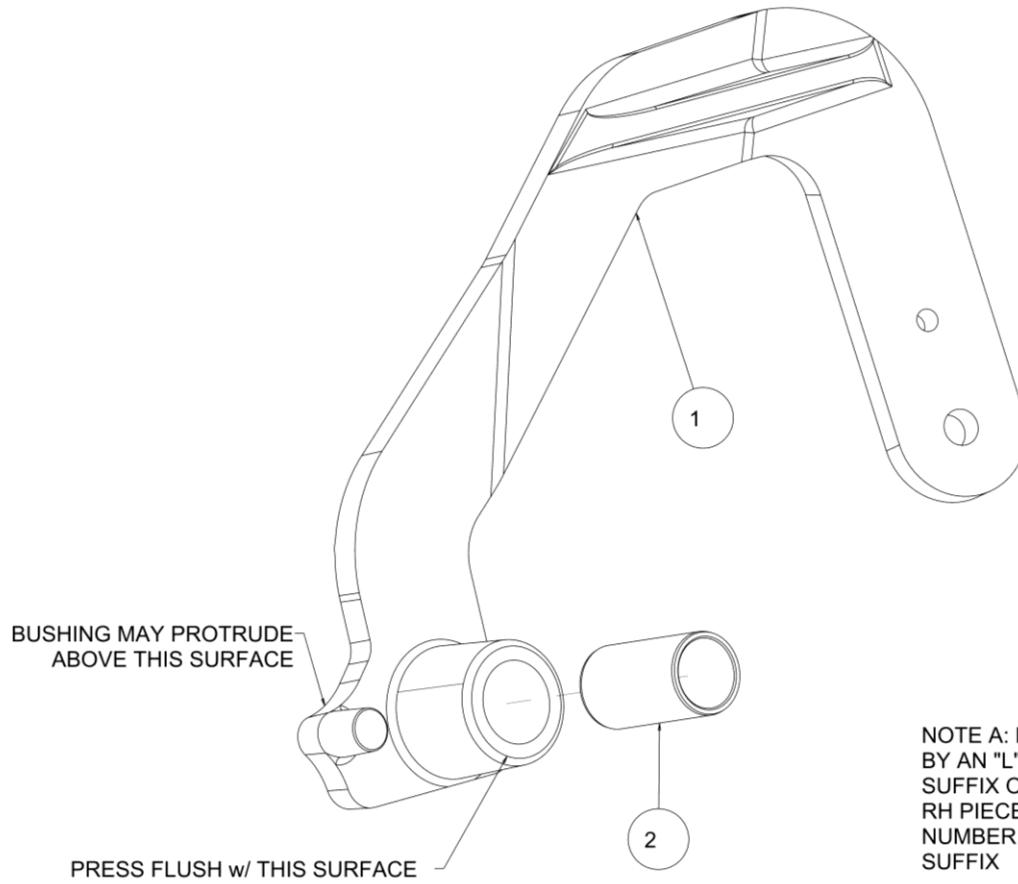

NOTE A: LH PARTS ARE DENOTED
BY AN "L" OR "LH"
SUFFIX ON PART NUMBER
RH PIECES HAVE THE SAME
NUMBER WITH "R" OR "RH" AS A
SUFFIX

	ITEM	PART #	DESCRIPTION	QTY
(A)	1	10000-304	L.H. CLOSE WHEEL ARM, MACHINE	1
	2	10000-318	BEARING SLEEVE 1.5 OD X 1.25 ID X 2.70	1

PART IDENTIFICATION

2987-142-L (SHOWN) & 2987-142-R CLOSING WHEEL ASSEMBLY

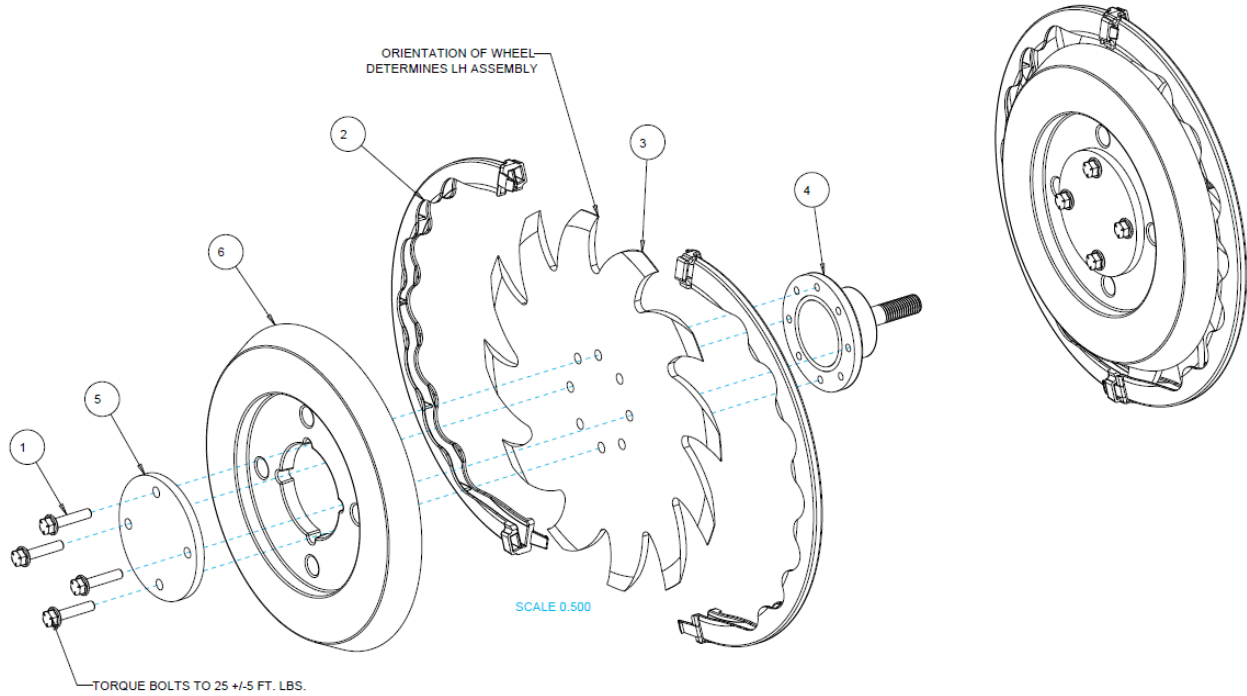

ITEM	PART NO.	DESCRIPTION	QTY
1	2502-225	5/16-18 X 1-1/2 HHFS GR5 ZP	4
2	2515-562	13" WHEEL COVER, BLACK	2
3	2571-286	SHARKTOOTH WHEEL, 8 BOLT	1
4	2965-501	HUB ASSEMBLY, 2.406 SPINDLE	1
5	2965-503	HUB CAP	1
6	2987-396	CAST PRESS WHEEL, PAINTED	1

PARTS IDENTIFICATION

10000-080-LH

RESIDUE MANAGER MOUNT KIT

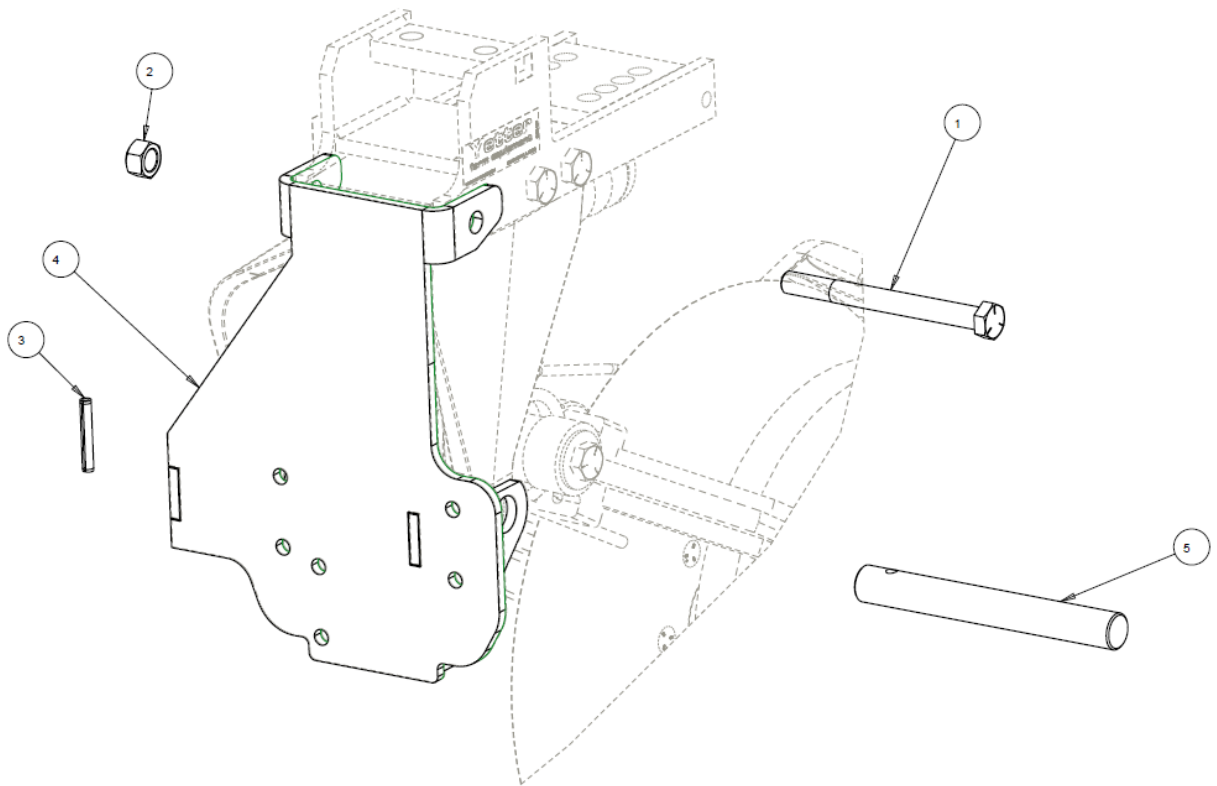

ITEM	PART NO.	DESCRIPTION	QTY
1	2502-405	3/4-10 X 8 HHCS GR. 5 ZP	1
2	2520-604	3/4-10 HEX TOP LOCK, GR. C, ZP	1
3	2530-208	3/8 X 2-1/2 ROLL PIN ZP	1
4	10000-207-LH	LH RESIDUE MANAGER MOUNT	1
5	10000-354	MAIN PIVOT PIN, ZP	1

PARTS IDENTIFICATION

10000-080-RH

RESIDUE MANAGER MOUNT KIT

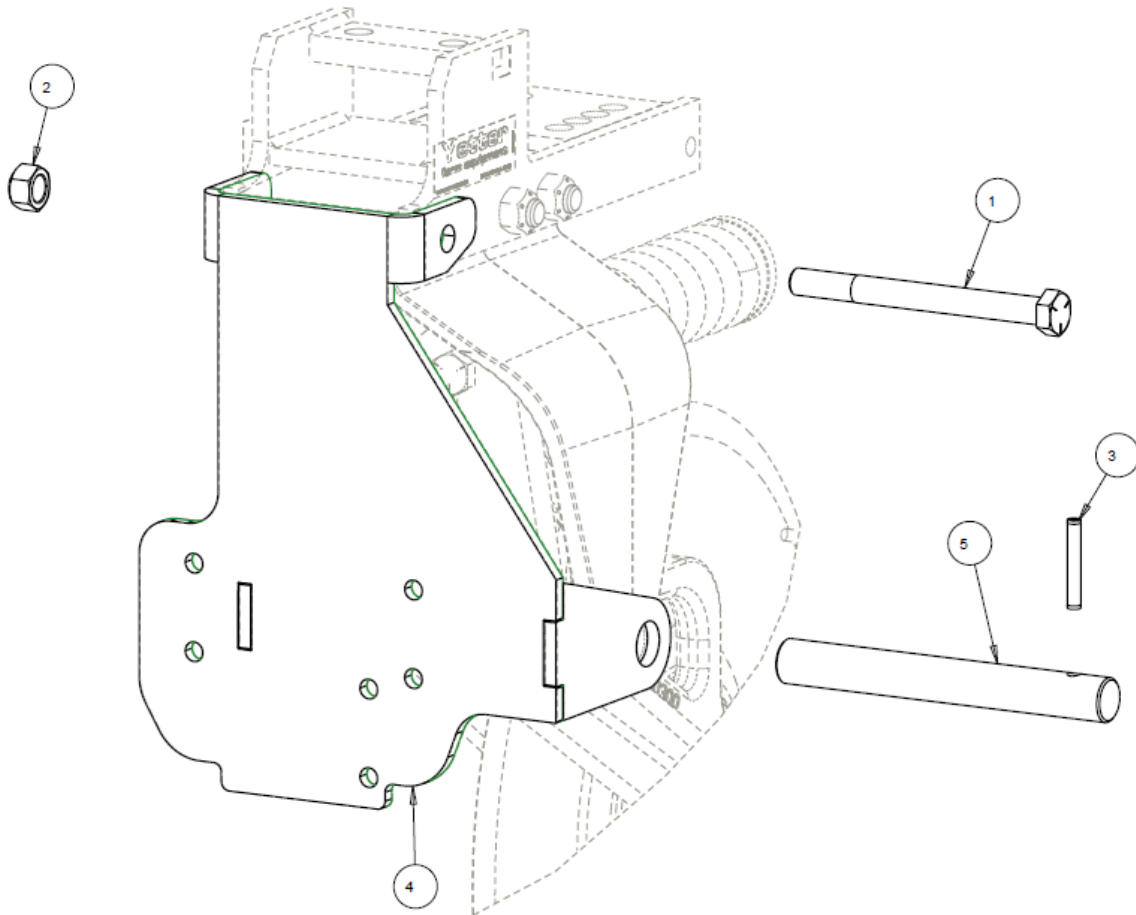

ITEM	PART NO.	DESCRIPTION	QTY
1	2502-405	3/4-10 X 8 HHCS GR. 5 ZP	1
2	2520-604	3/4-10 HEX TOP LOCK, GR. C, ZP	1
3	2530-208	3/8 X 2-1/2 ROLL PIN ZP	1
4	10000-207-RH	RH RESIDUE MANAGER MOUNT	1
5	10000-354	MAIN PIVOT PIN, ZP	1

PARTS IDENTIFICATION

10000-117 LEFT HAND MAGNUM OFFSET KIT

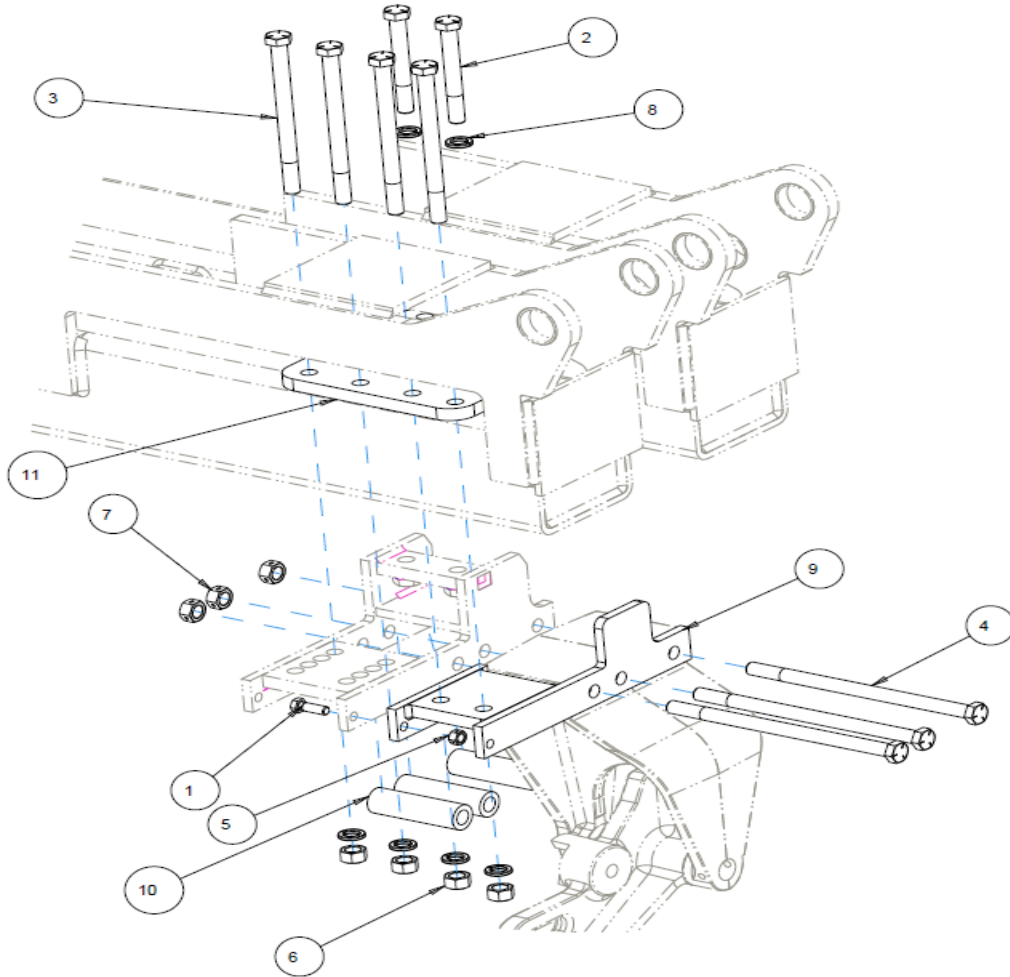

ITEM	PART NO.	DESCRIPTION	QTY
1	2502-294	1/2-13 X 1-1/2 HHCS GR5 ZP	1
2	2502-510	3/4-10 X 6 HHCS GR.5 ZP	2
3	2502-516	3/4-10 X 9-1/2 HHCS GR5 ZP	4
4	2502-526	3/4-10 X 13 HHCS GR 5 ZP	3
5	2520-357	1/2-13 LOCK HEX NUT, GR A, ZP	1
6	2520-506	3/4-10 HEX NUT, GR 8, ZP	4
7	2520-515	3/4-10 LOCK HEX NUT, GR A, ZP	3
8	2525-501	3/4 MED. LOCKWASHER ZP.	6
9	10000-208	OFFSET MOUNT W.A., RH	1
10	10000-356	SUPPORT SPACER	3
11	10000-357	OFFSET MOUNT PLATE	1

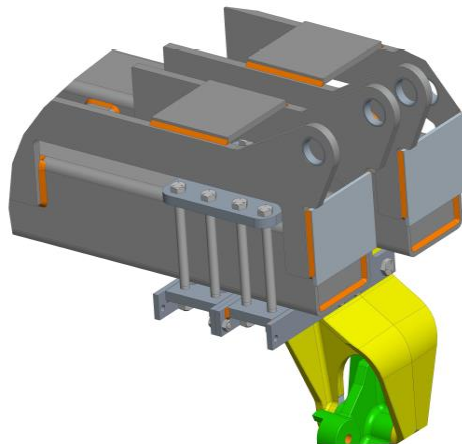

PARTS IDENTIFICATION

10000-118 LEFT HAND MAGNUM OFFSET KIT

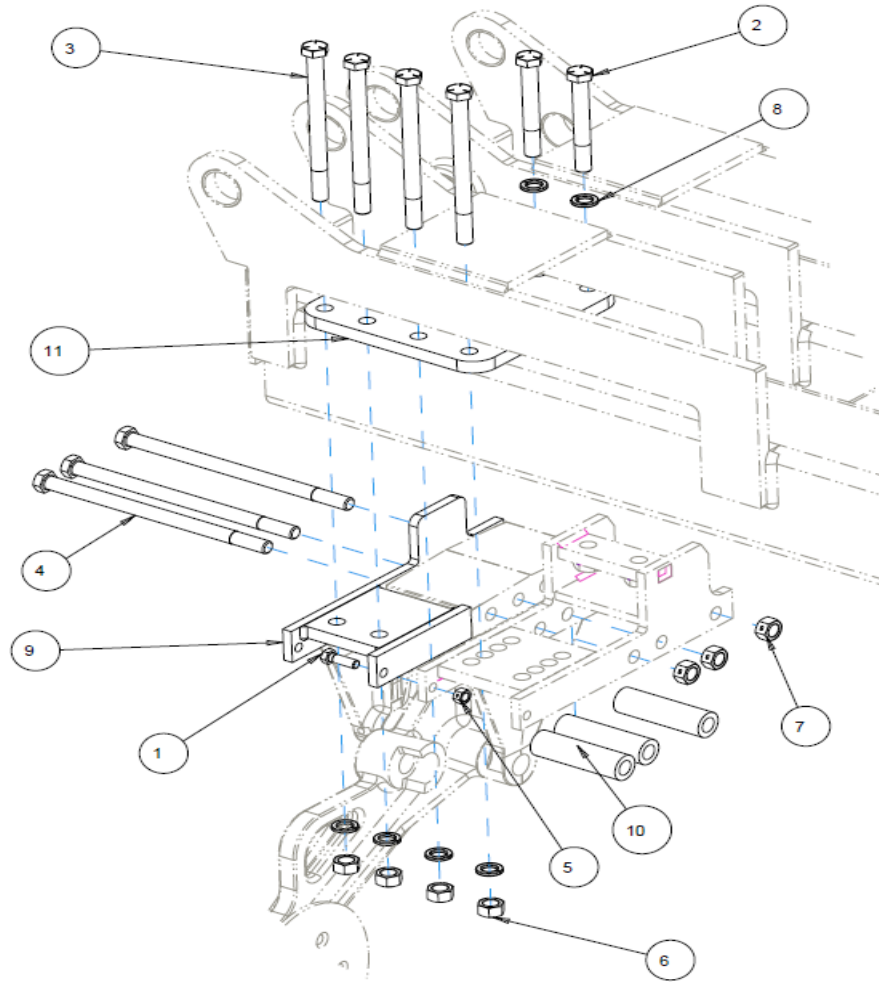

ITEM	PART NO.	DESCRIPTION	QTY
1	2502-294	1/2-13 X 1-1/2 HHCS GR5 ZP	1
2	2502-510	3/4-10 X 6 HHCS GR.5 ZP	2
3	2502-516	3/4-10 X 9-1/2 HHCS GR5 ZP	4
4	2502-526	3/4-10 X 13 HHCS GR 5 ZP	3
5	2520-357	1/2-13 LOCK HEX NUT, GR A, ZP	1
6	2520-506	3/4-10 HEX NUT, GR 8, ZP	4
7	2520-515	3/4-10 LOCK HEX NUT, GR A, ZP	3
8	2525-501	3/4 MED. LOCKWASHER ZP.	6
9	10000-209	OFFSET MOUNT W.A., LH	1
10	10000-356	SUPPORT SPACER	3
11	10000-357	OFFSET MOUNT PLATE	1

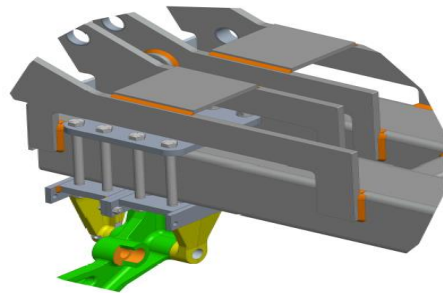

PART IDENTIFICATION

2987-040-R (SHOWN) & 2987-040-L NH3 (3/8" TUBE) FERTILIZER KIT

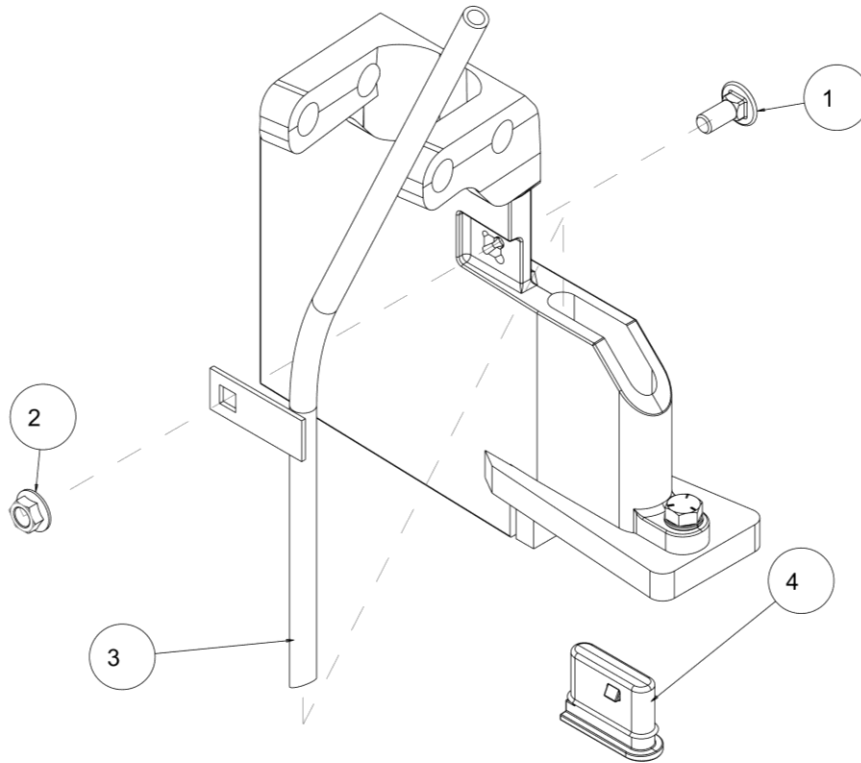

NOTE A: LH PARTS ARE DENOTED BY AN "L" OR "LH" SUFFIX ON PART NUMBER
RH PIECES HAVE THE SAME NUMBER WITH "R" OR "RH" AS A SUFFIX

ITEM	PART #	DESCRIPTION	QTY
1	2505-205	5/16-18 X 3/4 CARBOLT G5 ZP	1
2	2520-206	5/16-18 FLANGE LOCK NUT	1
(A) 3	2987-248-R	RH FERT TUBE W.A. L/N	1
4	2987-412	FULL PLUG	1

PART IDENTIFICATION

2987-041-R (SHOWN) & 2987-041-L NH3 (3/8" DUAL TUBE) FERTILIZER KIT

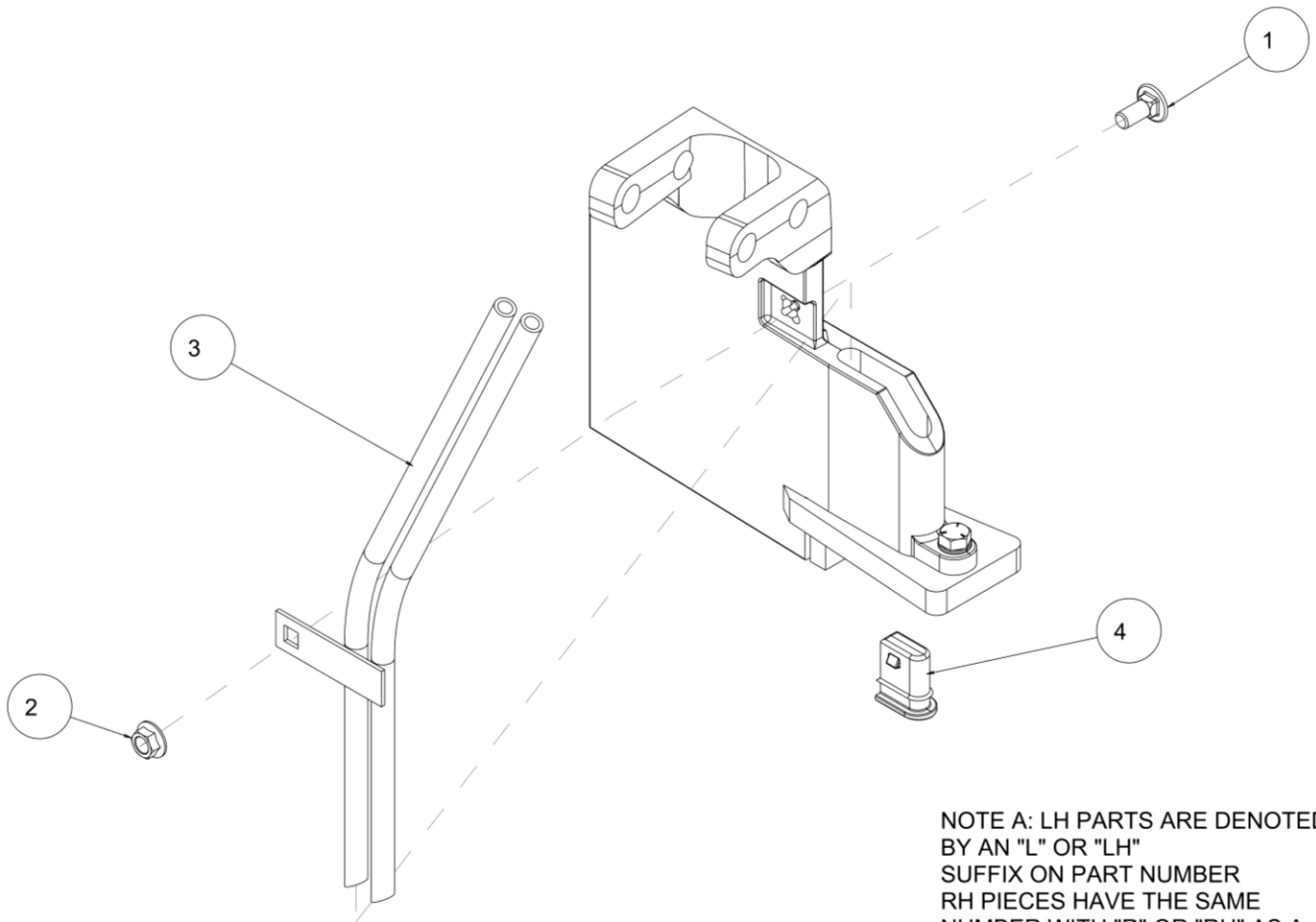

NOTE A: LH PARTS ARE DENOTED
BY AN "L" OR "LH"
SUFFIX ON PART NUMBER
RH PIECES HAVE THE SAME
NUMBER WITH "R" OR "RH" AS A
SUFFIX

ITEM	PART #	DESCRIPTION	QTY
1	2505-205	5/16-18 X 3/4 CARBOLT G5 ZP	1
2	2520-206	5/16-18 FLANGE LOCK NUT	1
(A) 3	2987-247-R	RH FERT TUBE W.A. NH3 W/LIQ	1
4	2987-414	3/4 PLUG	1

PART IDENTIFICATION

2987-042-R (SHOWN) & 2987-042-L
NH3 w/ VAPOR (3/8" & 3/4" TUBE) KIT

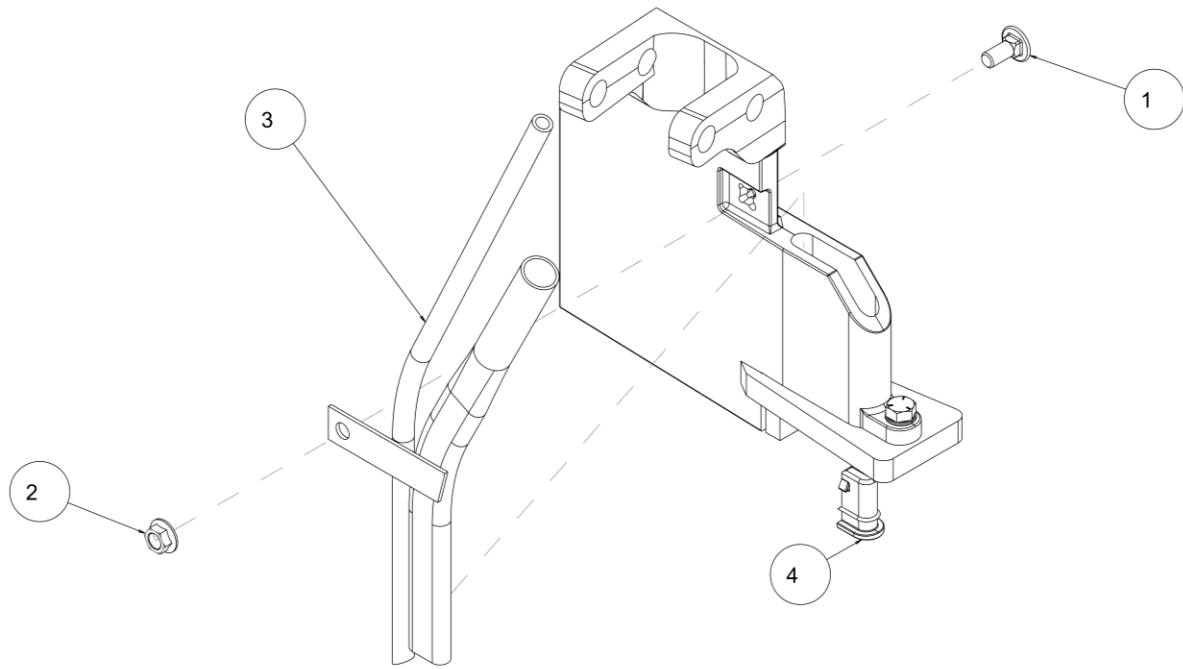

NOTE A: LH PARTS ARE DENOTED
BY AN "L" OR "LH"
SUFFIX ON PART NUMBER
RH PIECES HAVE THE SAME
NUMBER WITH "R" OR "RH" AS A
SUFFIX

ITEM	PART #	DESCRIPTION	QTY
1	2505-205	5/16-18 X 3/4 CARBOLT G5 ZP	1
2	2520-206	5/16-18 FLANGE LOCK NUT	1
(A) 3	2987-246-R	RH FERT TUBE W.A. NH3 W/V	1
4	2987-413	1/2 PLUG	1

PART IDENTIFICATION

2987-043-R (SHOWN) & 2987-043-L
NH3 w/ VAPOR (3/8" DUAL & 3/4" SINGLE TUBE) KIT

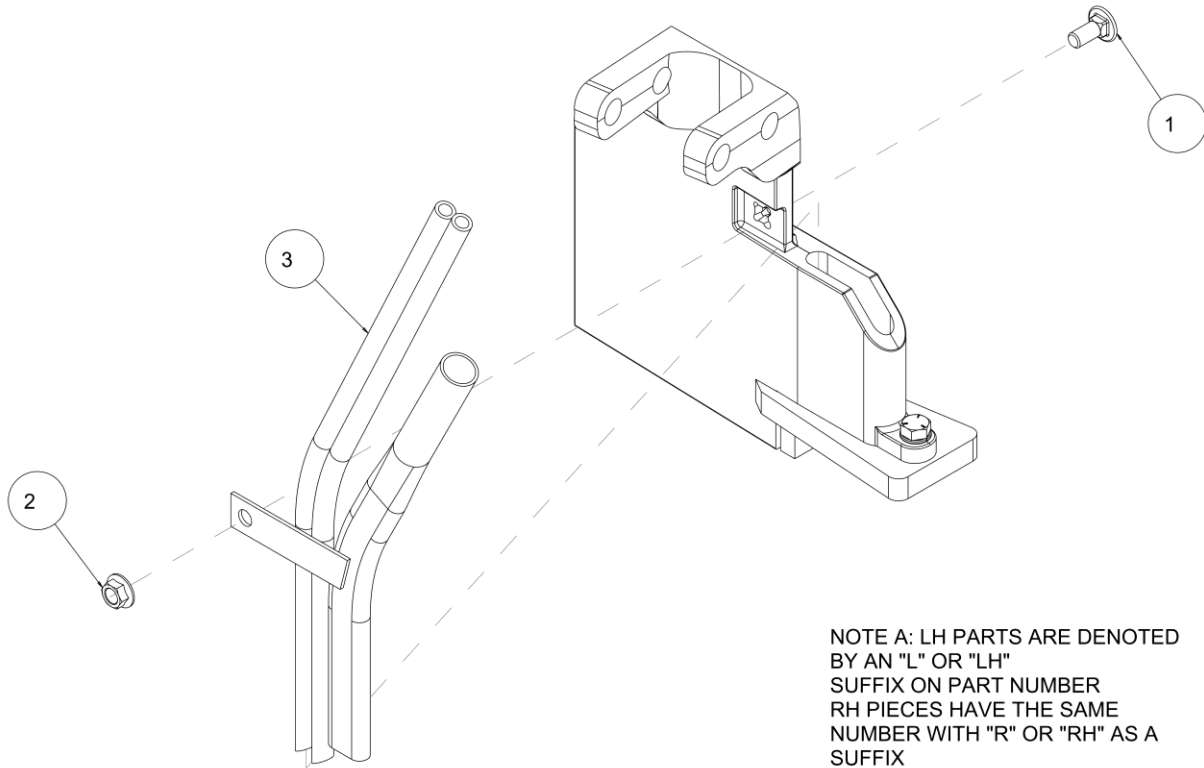

ITEM	PART #	DESCRIPTION	QTY
1	2505-205	5/16-18 X 3/4 CARBOLT G5 ZP	1
2	2520-206	5/16-18 FLANGE LOCK NUT	1
(A) 3	2987-249-R	RH FERT TUBE W.A. NH3, LIQ, VAPOR	1

PART IDENTIFICATION

2987-044-R (SHOWN) & 2987-044-L
NH3 VAPOR ONLY (3/4" TUBE) KIT

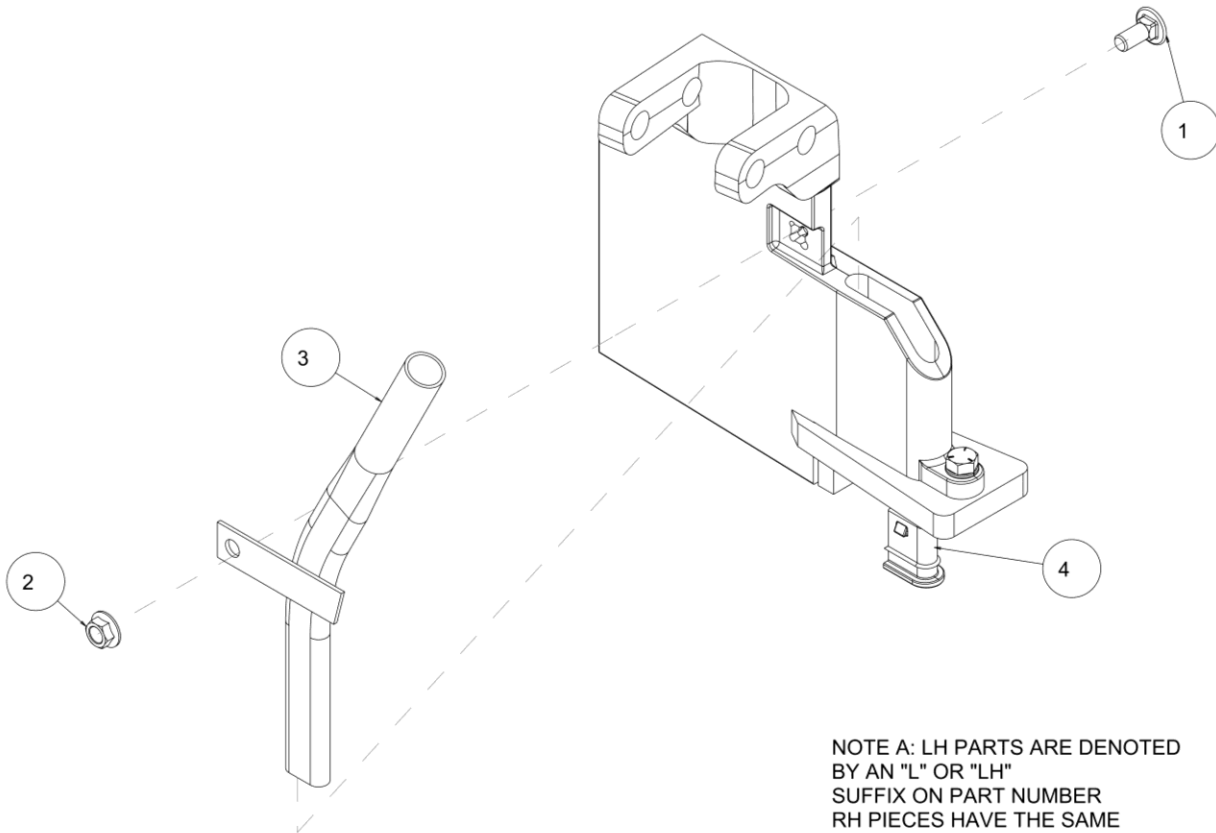

NOTE A: LH PARTS ARE DENOTED
BY AN "L" OR "LH"
SUFFIX ON PART NUMBER
RH PIECES HAVE THE SAME
NUMBER WITH "R" OR "RH" AS A
SUFFIX

ITEM	PART #	DESCRIPTION	QTY
1	2505-205	5/16-18 X 3/4 CARBOLT G5 ZP	1
2	2520-206	5/16-18 FLANGE LOCK NUT	1
(A) 3	2987-251-R	RH FERT TUBE W.A. VAPOR ONLY	1
4	2987-414	3/4 PLUG	1

PART IDENTIFICATION

2987-046 LIQUID (1/2" SINGLE TUBE) KIT

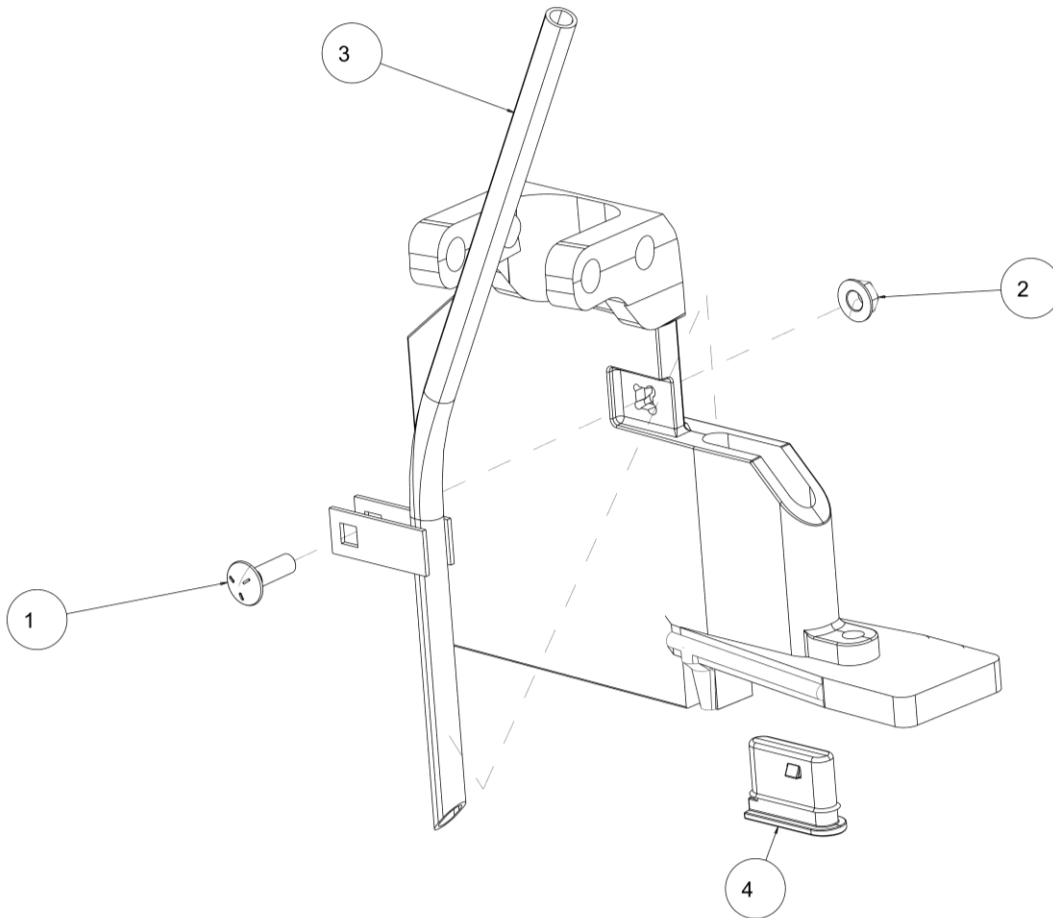

ITEM	PART #	DESCRIPTION	QTY
1	2505-206	5/16-18 X 1 CARBLT GR5 ZP	1
2	2520-206	5/16-18 FLANGE LOCK NUT	1
3	2987-252	1/2" LIQ TUBE W.A.	1
4	2987-412	FULL PLUG	1

PART IDENTIFICATION

2987-047 LIQUID (1/2" DUAL TUBE) KIT

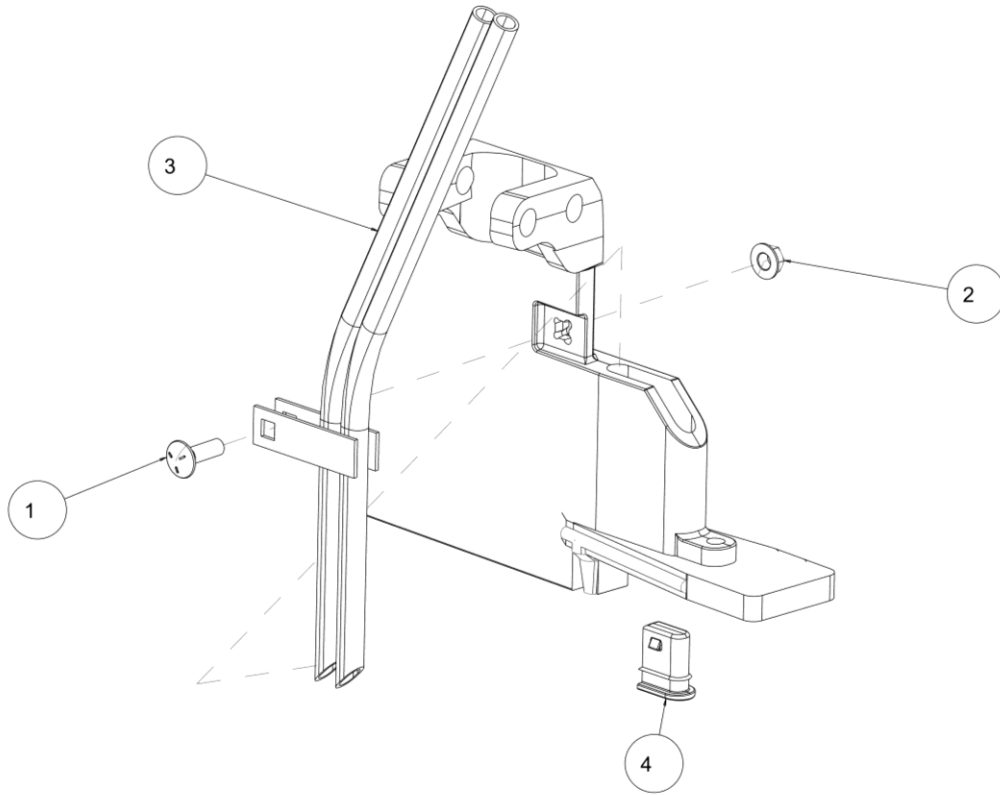

ITEM	PART #	DESCRIPTION	QTY
1	2505-206	5/16-18 X 1 CARBLT GR5 ZP	1
2	2520-206	5/16-18 FLANGE LOCK NUT	1
3	2987-253	1/2" DUAL LIQ TUBE W.A.	1
4	2987-414	3/4 PLUG	1

PART IDENTIFICATION

10000-050-LH (SHOWN) & 10000-050-RH
MAGNUM GRANULAR FERTILIZER TUBE KIT

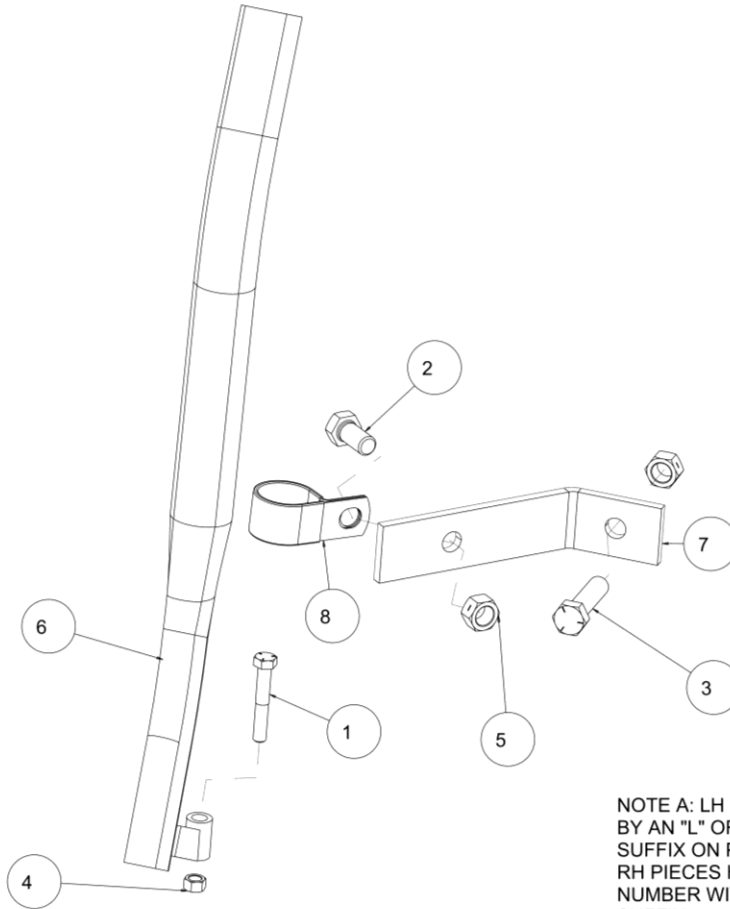

NOTE A: LH PARTS ARE DENOTED BY AN "L" OR "LH" SUFFIX ON PART NUMBER
RH PIECES HAVE THE SAME NUMBER WITH "R" OR "RH" AS A SUFFIX

ITEM	PART #	DESCRIPTION	QTY
1	2502-207	5/16-18 X 2 HHCS GR5 ZP	1
2	2502-292	1/2-13 X 1 HHCS GR5 YD	1
3	2502-351	1/2-13 X 2 HHCS GR.5 ZP	1
4	2520-201	5/16-18 HEX NUT ZP	1
5	2520-358	1/2-13 LOCK HEX NUT, GR8, ZP	2
(A) 6	10000-206-LH	MAGNUM LH DRY FERT TUBE, W.A.	1
7	10000-345	DRY TUBE SUPPORT	1
8	10000-346	LOOP CLAMP - VINYL CUSHIONED 1.5" I.D.	1

PART IDENTIFICATION

2987-406 RH (TOP) & 2987-407 LH (BOTTOM) MAGNUM KNIFE ATTACHMENT

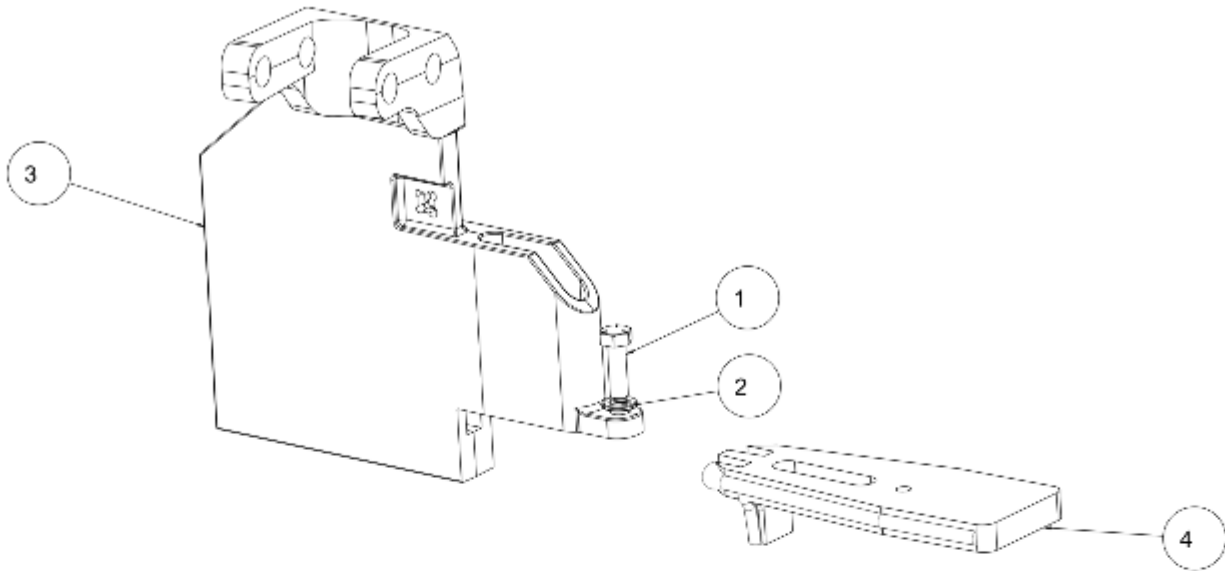

ITEM	PART #	DESCRIPTION	QTY
1	2502-198	5/16-18 X 1 HHCS GR.5 ZP	1
2	2525-201	5/16 MED. LOCKWASHER ZP.	1
3	2987-406-C	SIDE KNIFE w/ CARBIDE RH	1
4	10000-250-RH	BEAVERTAIL RH W.A., 2IN	1

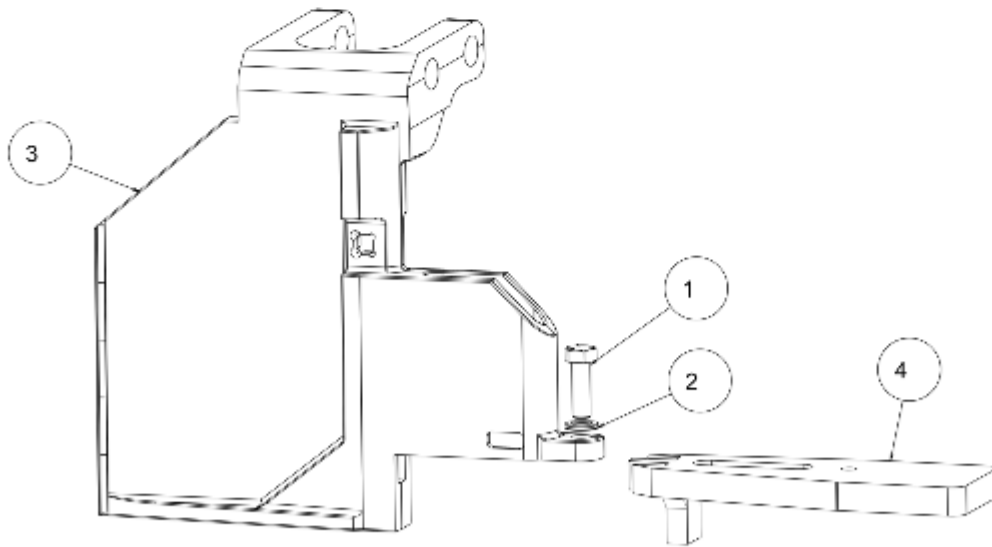

ITEM	PART #	DESCRIPTION	QTY
1	2502-198	5/16-18 X 1 HHCS GR.5 ZP	1
2	2525-201	5/16 MED. LOCKWASHER ZP.	1
3	2987-407-C	SIDE KNIFE w/ CARBIDE LH	1
4	10000-250-LH	BEAVERTAIL LH W.A., 2IN	1

PART IDENTIFICATION

10000-250-LH & 10000-250-RH
MAGNUM BEAVERTAIL

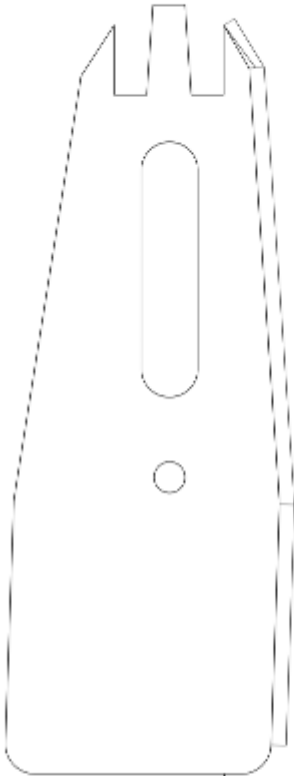

10000-250-LH
LEFT-HAND BEAVERTAIL

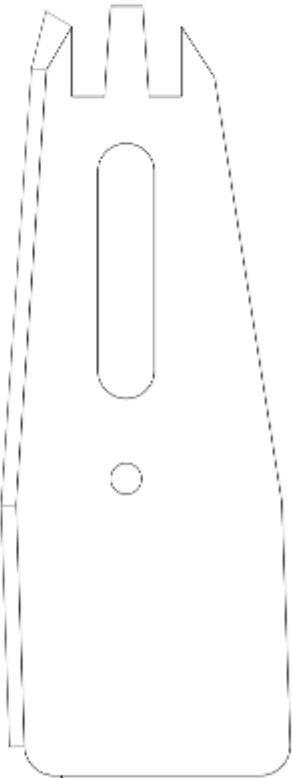

10000-250-RH
RIGHT-HAND BEAVERTAIL

Our name

Is getting known

Just a few years ago, Yetter products were sold primarily to the Midwest only. Then we embarked on a program of expansion and moved into the East, the South, the West and now north into Canada. We're even getting orders from as far away as Australia and Africa.

So, when you buy Yetter products . . .you're buying a name that's recognized. A name that's known and respected. A name that's become a part of American agriculture and has become synonymous with quality and satisfaction in the field of conservation tillage.

Thank you.

YETTER MANUFACTURING CO.

Colchester, IL 62326-0358 • 309/776-4111

Toll Free 800/447-5777

Fax 309/776-3222

Website: WWW.YETTERCO.COM

E-MAIL: INFO@YETTERCO.COM

2565-957_Rev_G 8/2022