



**6200-010/-011/-020/-021
13" SPIKE
CLOSING WHEELS**

OPERATOR'S MANUAL
PARTS IDENTIFICATION
2565-769 2/2012

YETTER MANUFACTURING CO.
FOUNDED 1930

Colchester, IL 62326-0358
Toll free: 800/447-5777
309/776-3222 (Fax)
Website: www.yetterco.com
E-mail: info@yetterco.com

YETTER

FOREWORD

You've just joined an exclusive but rapidly growing club.

For our part, we want to welcome you to the group and thank you for buying a Yetter Product.

We hope your new Yetter products will help you achieve both increased productivity and increased efficiency so that you may generate more profit.

This operator's manual has been designed into six major sections: Foreword, Safety Precautions, assembly instructions, Operation, parts identification and troubleshooting.

Throughout the manual references may be made to left side and right side. These terms are used as viewed from the operator's seat facing the front of the tractor.



This **SAFETY ALERT SYMBOL** indicates important safety messages in the manual. When you see this symbol, be alert to the possibility of **PERSONAL INJURY** and carefully read the message that follows.

The word **NOTE** is used to convey information that is out of context with the manual text. It contains special information such as specifications, techniques, reference information and other information of a supplementary nature.

The word **IMPORTANT** is used in the text when immediate damage will occur to the machine due to improper technique or operation. Important will apply to the same information as specified by note only of an immediate and urgent nature.



It is the responsibility of the user to read the operator's manual and comply with the safe and correct operating procedure and to lubricate and maintain the product according to the maintenance schedule in the operator's manual.

The user is responsible for inspecting his machine and for having parts repaired or replaced when continued use of the product would cause damage or excessive wear to the other parts.

It is the user's responsibility to deliver his machine to the Yetter dealer who sold him the product for service or replacement of defective parts that are covered by the warranty policy.

If you are unable to understand or follow the instructions provided in the publication, consult you local Yetter dealer or contact:

YETTER MANUFACTURING CO.

309/776-4111

800/447-5777

309/776-3222 (FAX)

Website: www.yetterco.com

E-mail: info@yetterco.com

WARRANTY POLICY

Yetter Manufacturing warrants all products manufactured and sold by it against defects in material. This warranty being expressly limited to replacement at the factory of such parts or products as will appear to be defective after inspection. This warranty does not obligate the Company to bear cost of labor in replacement of parts. It is the policy of the company to make improvements without incurring obligations to add them to any unit already sold. No warranty is made or authorized to be made, other than herein set forth. This warranty is in effect for one year after purchase.

DEALER _____

Yetter Manufacturing warrants its own products only and cannot be responsible for damage to equipment on which mounted.

SAFETY

A brief description of signal words that may be used in this manual:

CAUTION: Used as a general reminder of good safety practices or to direct attention to unsafe practices.

WARNING: Denotes a specific potential hazard.

DANGER: Denotes the most serious specific potential hazard.

SAFETY PRECAUTIONS

You can make your farm a safer place to live and work if you observe the safety precautions given. Study these precautions carefully and insist that they be followed by those working with you and for you.

WARNING

Never clean, lubricate or adjust a machine that is in motion. Always lower or block the implement before performing service.

If machine must be serviced in the raised position, jack or block it up to prevent it from accidentally falling and injuring someone.

Do not allow riders on the tractor or implement.

Use speeds and caution dictated by the terrain being traversed. Do not operate on any slope steep enough to cause tipping or loss of control.

Be sure all personnel are clear of the immediate area before operating.

Read and understand the operator's manual and require all other persons who will operate the equipment to do the same.

Be familiar with all tractor and implement controls and be prepared to stop engine and implements quickly in an emergency.

CAUTION

Consult your implement and tractor operator's manual for correct and safe operating practices.

Beware of towed implement width and allow safe clearance.

FAILURE TO HEED MAY RESULT IN PERSONEL INJURY OR DEATH.

BOLT TORQUE

Mounting bolts and hardware





Before operating the 6200 Spike Closing Wheel for the first time, check to be sure that all hardware is tight. Check all hardware again after approximately 50 hours of operation and at the beginning of each planting season.

All hardware used is Grade 5 unless otherwise noted. Grade 5 cap screws are marked with three radial lines on the head. If hardware must be replaced, be sure to replace it with hardware of equal size, strength and thread type. Refer to the torque values chart when tightening hardware.

 **Important:** Over tightening hardware can cause as much damage as when under tightening. Tightening hardware beyond the recommended range can reduce its shock load capacity.

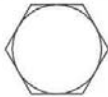
The chart below is a guide for proper torque. Use it unless a specified torque is called out elsewhere in the manual.
Torque is the force you apply to the wrench handle or the cheater bar, times the length of the handle or bar.
Use a torque wrench whenever possible.

The following table shows torque in ft. lbs. for coarse thread hardware.

BOLT DIA. AND THREADS PER INCH	 GRADE 2	 GRADE 5	OR  A-325	 GRADE 8
3/8-16	25		35	50
7/16-14	35		55	80
1/2-13	55		85	125
9/16-12	75		125	175
5/8-11	105		170	235
3/4-10	185		305	425
7/8-9	170		445	690
1-8	260		670	1030
1 1/8-7	365		900	1460
1 1/4-7	515		1275	2060
1 3/8-6	675		1675	2700
1 1/2-6	900		2150	3500
1 3/4-5	1410		3500	5600

Lubricate all bearings and moving parts as assembled and make certain that they work freely.



WARNING: Never work around the toolbar/implement while in a raised position without using safety lockups.



CAUTION: The 6200 Spike Closing Wheel attachments are very heavy. Pay extra attention to lifting techniques while handling and or maneuvering the opener during assembly. Failure to do so may lead to personal injury.

OPERATION

Attach the wheel assembly to the close wheel arm using the provided hardware. **NOTE:** Use the washers as necessary for lateral adjustment of the closing wheel in relationship to the seed furrow. 6200-011 is illustrated in diagram below.

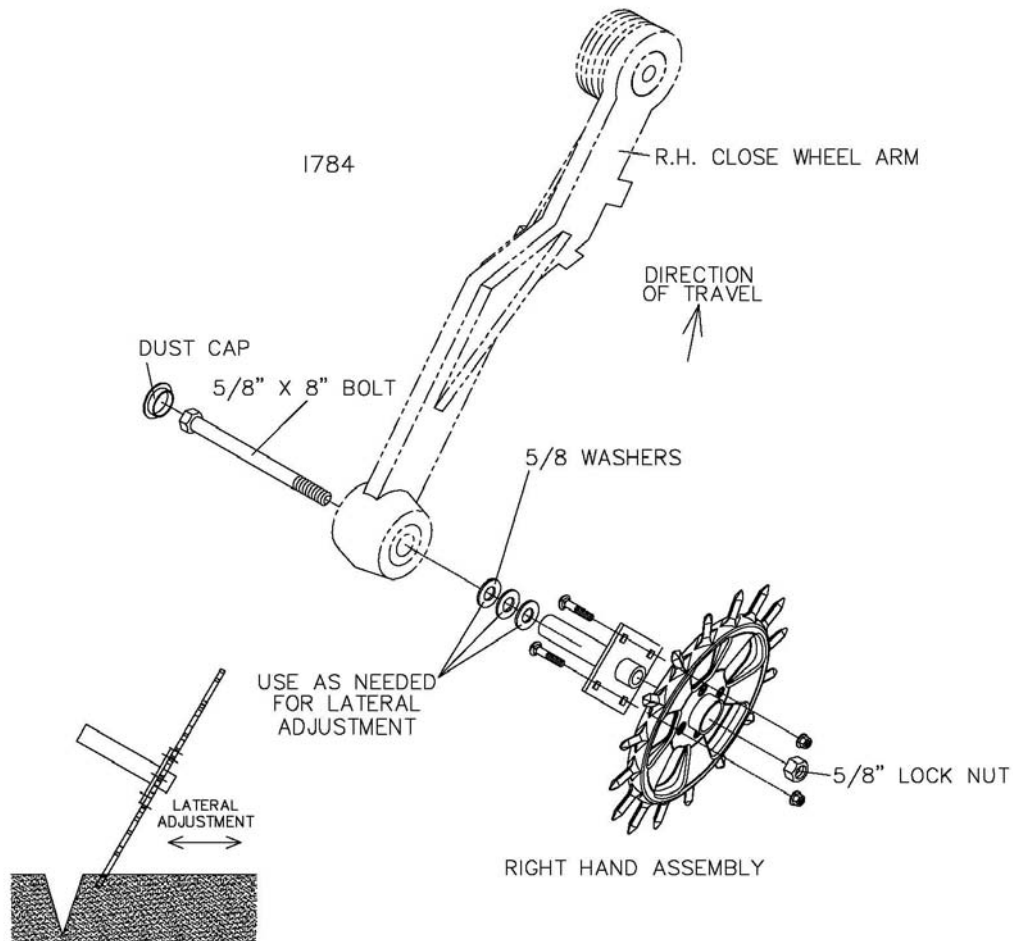

Lateral adjustment is important because the seed furrow may not be covered/closed if the closing wheel is too far from the seed furrow; or the seed placement will be effected if the close wheel is too close to the seed furrow.

The 6200 Spike Closing Wheel is designed to crumble the sidewall not to "squeeze" the sidewall. For this reason it is important that the firming wheel is functioning properly and supplying adequate pressure on the seed that is being planted.

PARTS IDENTIFICATION

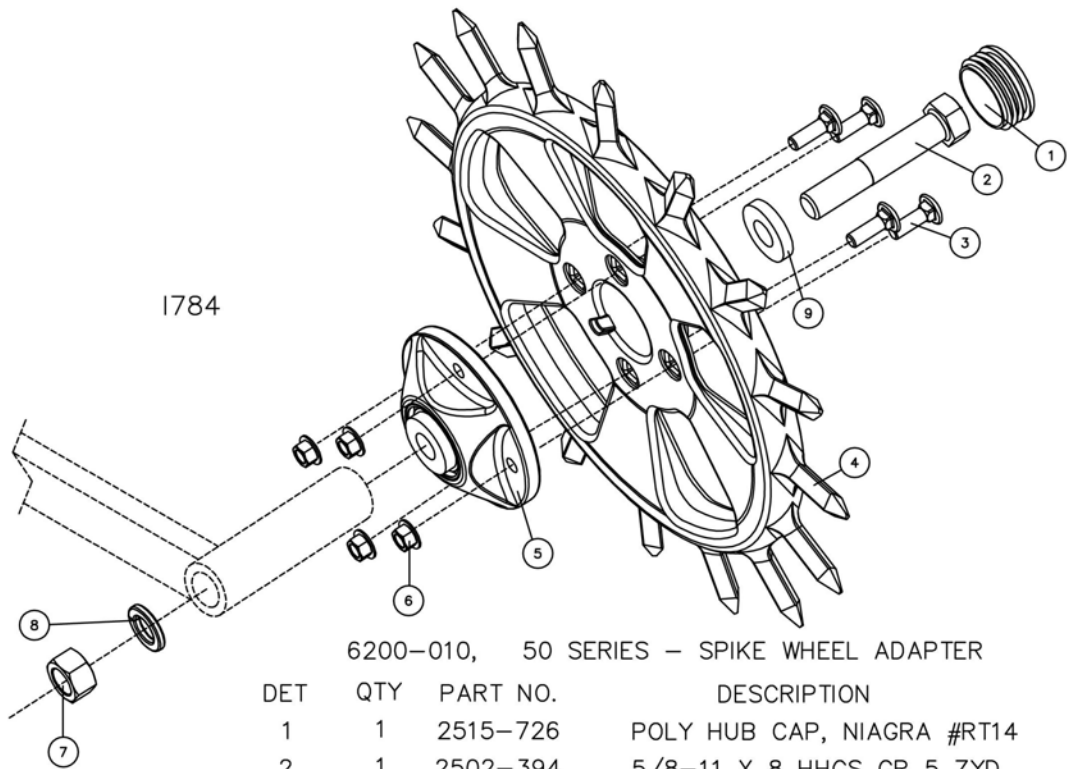

6200-010, 50 SERIES - SPIKE WHEEL ADAPTER

DET	QTY	PART NO.	DESCRIPTION
1	1	2515-726	POLY HUB CAP, NIAGRA #RT14
2	1	2502-394	5/8-11 X 8 HHCS GR 5 ZYD.
3	4	2505-206	5/16-18 X 1 CAR BLT GR 5 ZYD.
4	1	6200-404	13" SPIKE WHEEL, CAST
5	1	2965-128	HUB AND BEARING ASS'Y., 4 BOLT
6	4	N10213	5/16-18 HEX FLANGE SERRATED NUT
7	1	2520-452	5/8-11 HEX NUT ZYD.
8	1	2525-451	5/8-11 MED LOCK WASHER ZYD.
9	1	2527-530	1.50D X 21/32ID 3/16TK MA BU

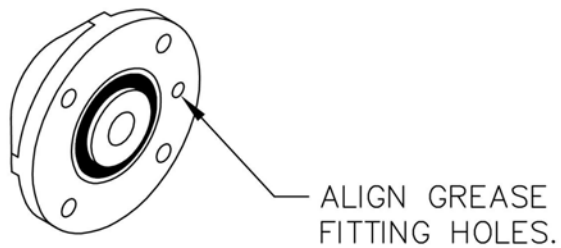

PARTS IDENTIFICATION

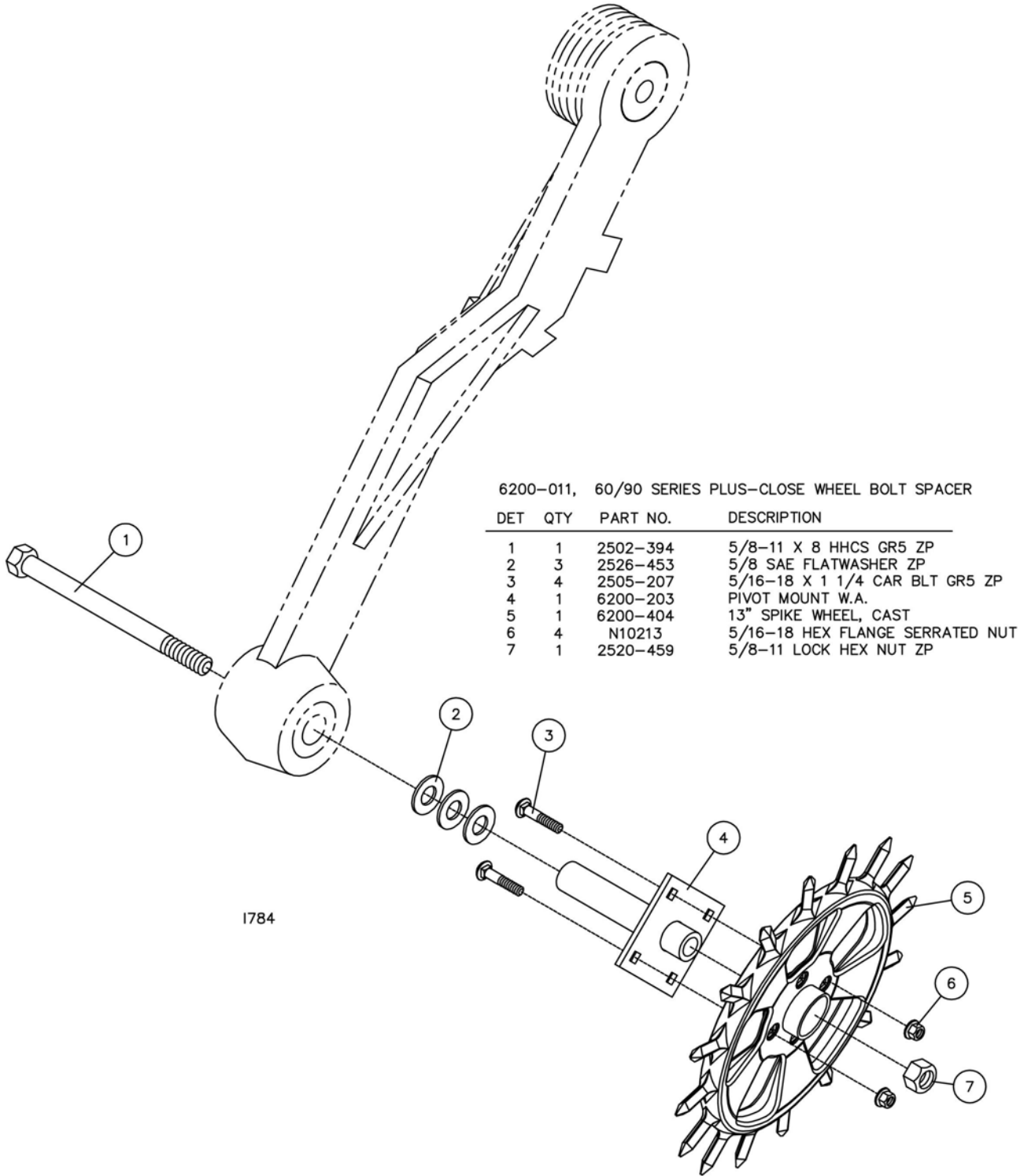

PARTS IDENTIFICATION

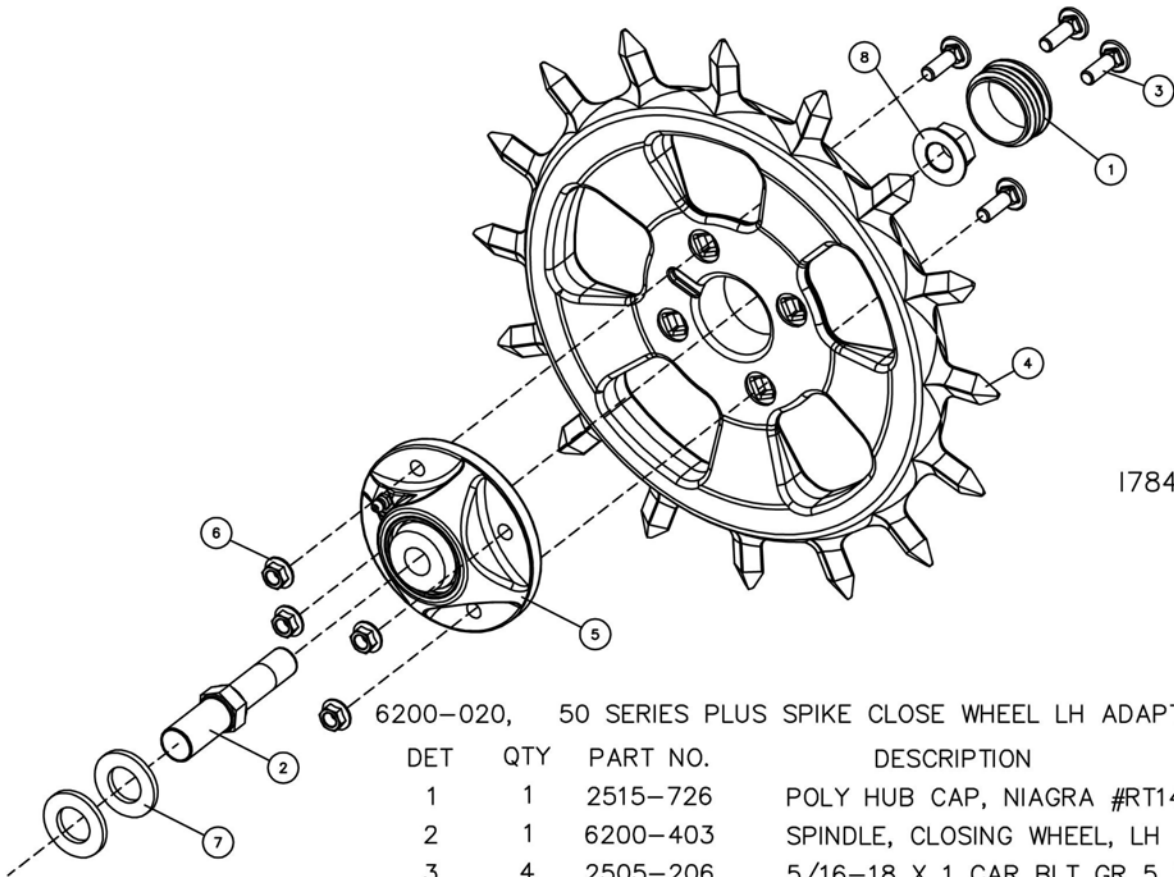

1784-3

6200-020, 50 SERIES PLUS SPIKE CLOSE WHEEL LH ADAPTOR 13'

DET	QTY	PART NO.	DESCRIPTION
1	1	2515-726	POLY HUB CAP, NIAGRA #RT14
2	1	6200-403	SPINDLE, CLOSING WHEEL, LH
3	4	2505-206	5/16-18 X 1 CAR BLT GR 5 ZYD.
4	1	6200-404	13" SPIKE WHEEL, CAST
5	1	2965-128	HUB AND BEARING ASS'Y., 4 BOLT
6	4	N10213	5/16-18 HEX FLANGE SERRATED NUT
7	2	2526-504	3/4 SAE FLATWASHER ZYD.
8	1	2520-464	5/8-11 WHIZLOCK HEX NUT ZYD.

PARTS IDENTIFICATION

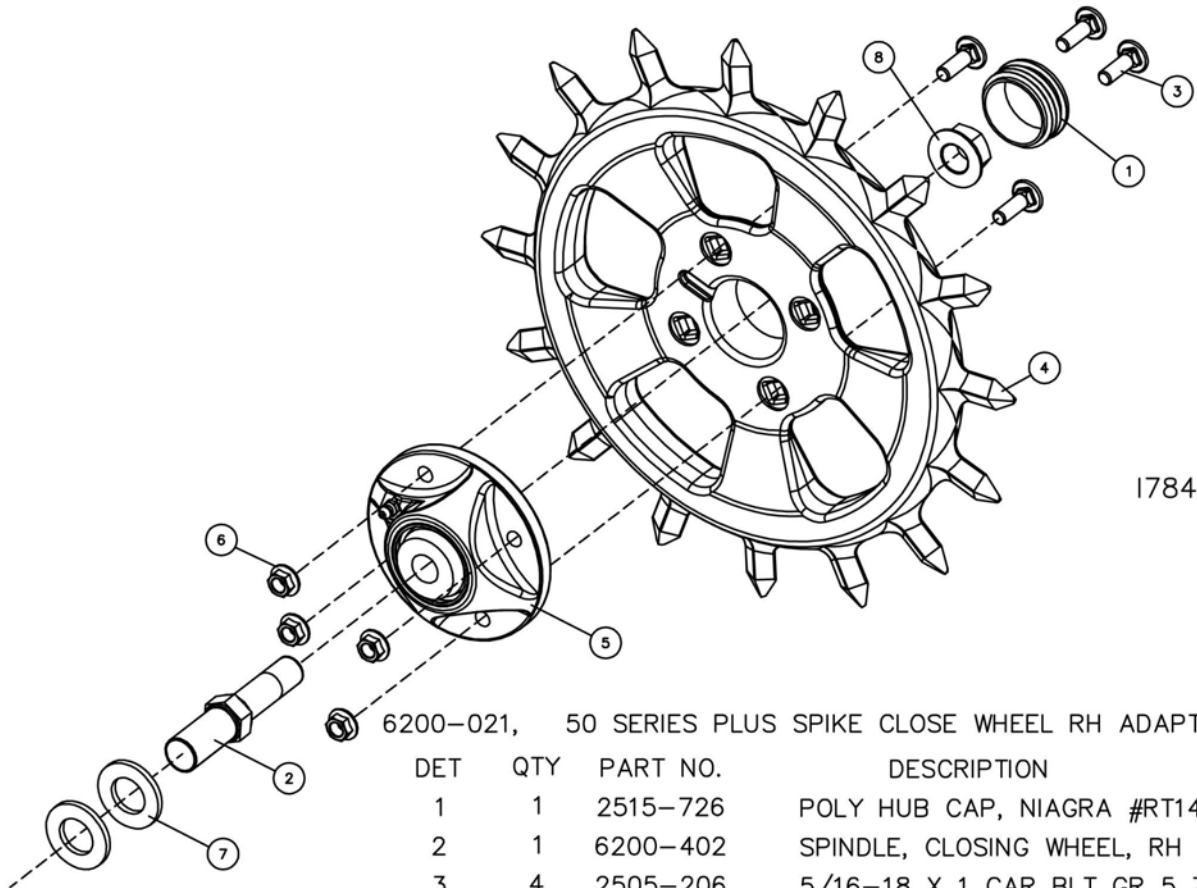

1784-4

6200-021, 50 SERIES PLUS SPIKE CLOSE WHEEL RH ADAPTOR 13'

DET	QTY	PART NO.	DESCRIPTION
1	1	2515-726	POLY HUB CAP, NIAGRA #RT14
2	1	6200-402	SPINDLE, CLOSING WHEEL, RH
3	4	2505-206	5/16-18 X 1 CAR BLT GR 5 ZYD.
4	1	6200-404	13" SPIKE WHEEL, CAST
5	1	2965-128	HUB AND BEARING ASS'Y., 4 BOLT
6	4	N10213	5/16-18 HEX FLANGE SERRATED NUT
7	2	2526-504	3/4 SAE FLATWASHER ZYD.
8	1	2520-464	5/8-11 WHIZLOCK HEX NUT ZYD.

NOTES:

NOTES:

Our name Is getting known

Just a few years ago, Yetter products were sold primarily to the Midwest only. Then we embarked on a program of expansion and moved into the East, the South, the West and now north into Canada. We're even getting orders from as far away as Australia and Africa.

So, when you buy Yetter products . . .you're buying a name that's recognized. A name that's known and respected. A name that's become a part of American agriculture and has become synonymous with quality and satisfaction in the field of conservation tillage.

Thank you.

YETTER MANUFACTURING CO.

Colchester, IL 62326-0358 • 309/776-4111

Toll Free 800/447-5777

Fax 309/776-3222

Website: WWW.YETTERCO.COM

E-MAIL: INFO@YETTERCO.COM

2565-769 • 02/2012