THE LEADING EDGE

www.yetterco.com · [Yetter Manufacturing Inc](http://www.yetterco.com) · [E-mail:info@yetterco.com](mailto:info@yetterco.com)

A PUBLICATION DEDICATED TO MAXIMIZING YIELD POTENTIAL

This article first appeared in The Leading Edge in December, and we had requests to send the article again closer to the planting season.

Planting and Seeding 101

The purpose of this guide is to provide useful information on how to maximize profit potential with planting equipment.

Objective: Identify how to properly adjust and maintain planting equipment for optimum performance in the field.

Conservation Planting Guide - Planting and Seeding 101

Row Crop Planter: Safety, Inspection / Maintenance, and Adjustment

Step 1. Safety! Read the operator's manual before taking your planter into the field. It is your responsibility to read the operator's manual and comply with the safety guidelines and correct operating procedures and to lubricate and maintain the product according to the maintenance schedule. Read the instructions carefully to acquaint yourself with the equipment. Working with unfamiliar equipment can lead to accidents. Please take time to check your planter for proper operation before you get to the field.

- A. Be safe. Never clean, lubricate, or adjust a machine that is in motion. Always install lockup mechanisms before servicing any equipment.
- B. Familiarize yourself with the machine and how to adjust it as field conditions change.
- C. Be in control. Haste makes waste. Make decisions wisely. Your life depends on it.
- D. Remember that accidents can be prevented.

Step 2. Maintenance. You cannot afford to operate a planter that is not properly maintained! You are responsible for inspecting the planter and having parts repaired on an as-needed basis.

- A. Be safe. Never clean, lubricate, or adjust a machine that is

in motion. Always install lockup mechanisms before servicing any equipment.

- B. **Tire pressure** – Make sure that the tires are adequately inflated per the recommendations in the operator’s manual.
 - 1. Proper inflation keeps the toolbar level to the soil surface.
 - 2. Proper inflation keeps the “drive tires” turning at the same speed; an under-inflated/low drive tire will do all the driving and increase the seeding population rate due to a smaller circumference.

Step 3. Planter Row Unit Inspection

- A. **Parallel linkage arms** – Worn parts can cause the row unit to operate in an unbalanced manner, affecting seed placement, closing wheel spring pressure, and row unit spring pressure.
 - 1. Inspect the parallel arms for wear (e.g., bushings, bolts, and elongated holes in the parallel arms).
 - 2. Look for bent, broken, and twisted parallel arms.
 - 3. Replace parts as necessary.
- B. **Seed tubes** – Worn or broken seed tubes can affect seed depth and spacing.
 - 1. Check the seed tubes for wear (e.g., split ends, holes, or cracks).
 - 2. Inspect the seed tube guard (i.e., inside scraper) for wear. A worn out guard is the leading cause of seed tube wear.
 - 3. Make sure that the seed tubes are hooked on the row unit to prevent floating tubes and uneven seed depth.
- C. **Disc opener blades** – Worn, cracked, or warped blades will affect seed placement, depth, and spacing. Consult the operator’s manual for proper adjustment procedures.
 - 1. Blades worn too small need to be replaced because they cannot be adjusted to have 2” of contact with each other.
 - 2. Adjust the blades to have 2” of contact with each other. Add or remove shims from both blades as equally as possible. Adjusting only one blade will cause uneven seed placement and facilitate wear on the seed tube.
 - 3. Replace the blade if it is warped or cracked.
 - 4. Replace the bearing or the complete blade and bearing assembly if the bearing is worn or loose. Failure to replace the bearing will cause uneven seed placement.
- D. **Depth control wheels** – Worn or improperly adjusted wheels will allow soil to fall into the seed furrow ahead of the seed causing uneven seed depth.
 - 1. Inspect the tire for wear or cracks. If the lip or the tire is worn away, the tire cannot be properly adjusted and

- should be replaced.
2. Inspect the bearings. The wheel must maintain continuous contact with the disc blade. If the bearings are loose, they should be replaced.
 3. Inspect the depth control arms. The arms must be able to pivot and adjusted so that the wheel makes continuous contact with the disc blade. Some arms are so loose that the tire touches the blade and can be pulled away 1" or more. Make sure the grease fitting will take grease. Remove and clean the gauge wheel arm pivot as necessary.
- E. **Seed boxes** – A misaligned seed box will cause the meter to drop seed into the seed tube.
1. Check the seed box for holes or cracks.
 2. Inspect the seed box for cleanliness. Make sure it is free of foreign objects (e.g., plant residue, paper, string, and buildup of seed treatments), which can obstruct seed flow to the meter.
 3. Seed boxes need to be evenly filled for even weight distribution across the planter.
- F. **Closing wheels** – It is important that the seed is covered with soil that is free of air pockets and compaction.
1. Inspect for good seed-to-soil contact.
 2. Inspect the closing wheel arm and pivot bushings or eccentric bushings. The parts must be in good condition to prevent the closing wheels from moving from side to side.
 3. Inspect the wheel. If it wobbles, replace the wheel or the bearing.

Step 4. Seed meter – Always thoroughly clean seed from the meter after planting! Meters should be stored in a heated area to prevent rust.

Finger Pick-Up Seed Meter

1. Inspect meter for worn, damaged, or missing parts.
2. Disassemble and check bearing.
3. Check finger assembly for rust, wear, or broken parts.
4. Check carrier plate for rust and wear.
5. Replace worn or broken parts!
6. Meters should be stored in a heated area.

Vacuum/Air Seed Meter

1. Disassemble and inspect meter for broken, worn, or missing parts.

2. Inspect and reinstall and/or replace seals.
3. Re-install plastic meter parts.
4. Install new brush.
5. Never store seed disks in row unit.
6. Seed discs should be cleaned in warm water and soap after planting. Follow cleaning recommendations as outlined in the operator's manual before storing.
7. Meters should be stored in a heated area.

Chains and idlers – Inspect chains and rollers for rust, wear, and damage. Lubricate with chain lube dry film lubricant, as petroleum-based lubricants attract dirt and facilitate wear.

1. Chains and idlers need to be examined daily.
2. Chains should be replaced annually.

Drive shafts, bearings, and transmissions – Bent or misaligned shafts or rough, worn bearings will affect seed meter operation and seed spacing.

1. Drive shafts and bearings need to be properly aligned to ensure smooth operation.
2. Drive sprockets and transmission gears need to be checked on a regular basis for wear and proper adjustment.
3. Transmission gears and spacers need to be properly lubricated (with dry film lubricant) to ease adjustment.

Step 5. Adjustment. Do not operate a planter that is not properly adjusted! The operator is responsible for inspecting the planter and knowing how to adjust the planter to adapt to different seeds, soil conditions, and tillage methods, and changes in weather. In order to make planting a success, it is imperative to understand the importance of planter adjustment. A properly adjusted planter allows you to be in control. There are many items on a planter that must be checked for working condition and proper settings for field conditions. Adjustments helps achieve precise seed depth and consistent spacing for optimum yields.

A. Planter frame – An improperly adjusted planter frame is the leading reason for uneven seed depth, spacing, and emergence, resulting in less than ideal plant population and yield.

1. Make sure that the planter frame height is adjusted to the manufacturer's recommendations. Consult the operator's manual. Important note: The measurement

must be checked when the planter is in the field and has been fully loaded with seed, fertilizer, pesticides, etc.

2. Make sure that the planter is level. **Important note:** The levelness of the planter frame is extremely critical because it affects the angle of the seed tube, seed depth, seed spacing, row unit mounted attachments, spring pressure, and closing wheels.

B. Seed depth – Seed placement is an important management decision. Properly positioning the seed is critical to developing healthy roots, minimizing stress, and producing yield. Seeds planted shallow have problems with root development, and seed planted deep have problems with emergence. It is important to understand how to make the correct adjustments to place the seed exactly at the precise depth in the soil.

1. Gauge wheel depth control – Check to ensure that the mechanism is working and that you can change the planting depth easily to adapt to changes in soil conditions.
2. Row unit down pressure – Use only enough force to hold the disc opener blades at the desired planting depth. Excessive pressure will cause the seed to be planted too deeply into the soil. Inadequate pressure will cause the seed to be planted too shallow. Check for broken or missing springs and replace as necessary.
3. Frame height and levelness – This adjustment is most critical to achieve the desired planting depth. Refer to the operator's manual for the correct setting and procedures when you need to make an adjustment.
4. Checking the seed depth – Visually check the depth of seed placement. This can be done easily by locking up the closing wheels so that the seed is visible and not covered with soil. Use a ruler or measuring tape as a straight edge to lie across the top of the seed furrow. Seed spacing and population can also be measured at this time.
5. Gauge wheels – Adjust the gauge wheels so that they are barely touching the disc blades. Replace wheels that are worn. Replace arms or bushings that allow the wheel to pull away from the disc blades. Use a dime to set the proper gap between the blade and gauge wheel. If gauge wheels are not adjusted properly, soil will fall into the furrow causing the seed to be planted too shallow.

C. Closing wheels – Improperly adjusted closing wheels could cause sidewall compaction and uneven stands, and they use a minimal amount of spring pressure to achieve seed-to-soil contact.

1. Adjust the closing wheels so that they are an equal distance from the center of the seed furrow.
2. The closing wheel arm and pivot bushings or eccentric bushings must be in good condition to prevent the closing wheels from moving from side to side.
3. Inspect the wheel. If it wobbles, replace it or the bearing as needed.
4. Adjust the spring pressure on the closing wheels according to soil type and moisture. Correctly adjusted spring pressure should eliminate air pockets in the seed furrow and cover the seed without creating compaction on top of the seed

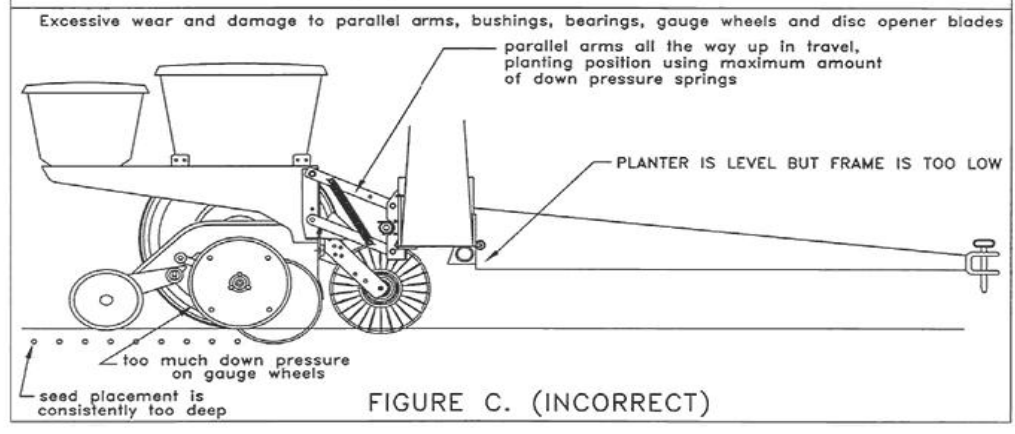
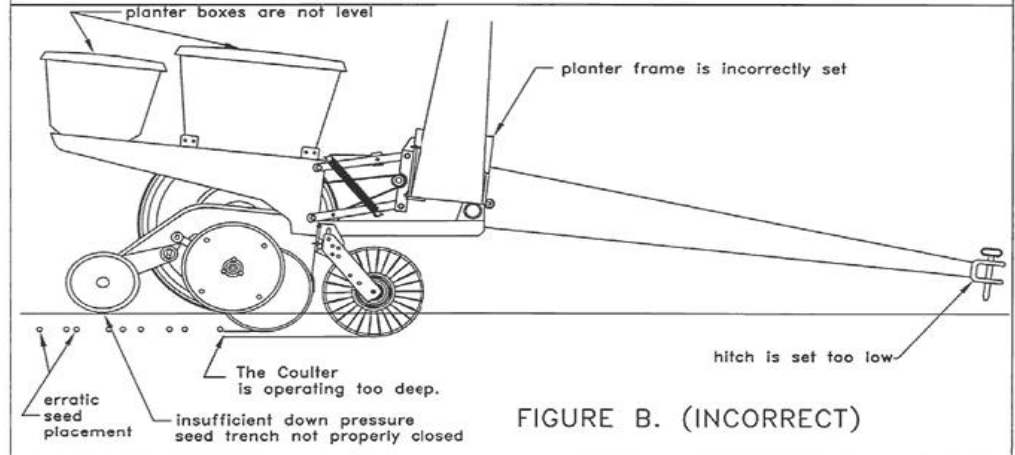
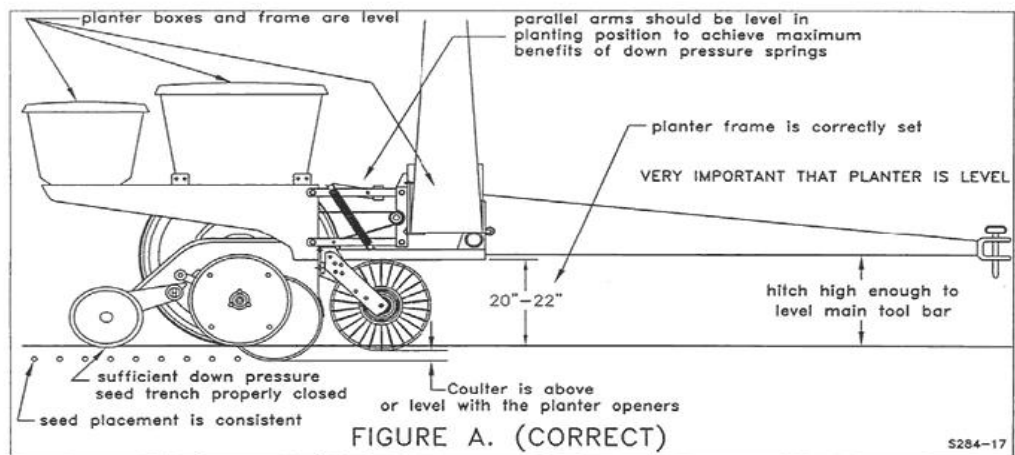

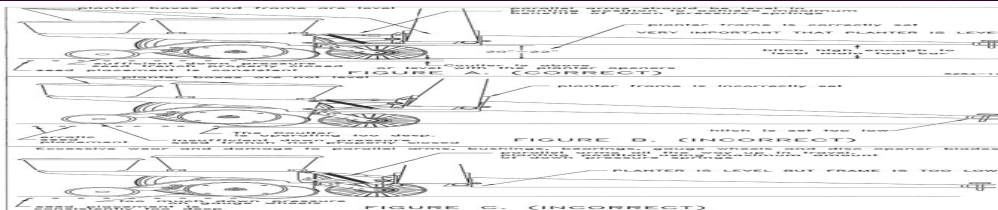

Visit www.yetterco.com to review past issues of The Leading Edge and Yetter products that maximize your yield potential.

Notice – The information contained in this guide is offered in good faith by Yetter Mfg. Co., Inc. to further the understanding of no-till farming. However, the use of the information provided is beyond the control of Yetter Mfg. Co., Inc. and in no case shall Yetter Mfg. Co., Inc. or any seller of its products be responsible for any damages which may occur from the use of this information. All such risks shall be assumed by the user.

Yetter Manufacturing Co., Inc.
109 S. McDonough
Colchester, Illinois 62326
Phone: 800-447-5777
FAX: 309-776-3222
www.yetterco.com
E-mail: info@yetterco.com



[PDF Version](#)