



2570-594 BEARING ASSEMBLY AND LUBRICATION

Practice Safety

Understand and practice safe service procedures before doing work. Follow ALL the operating, maintenance and safety information in the equipment operator manual. Clear the area of bystanders, especially small children, when performing any maintenance or adjustments. Keep work area clean and dry. Use adequate lighting for the job. Use only tools, jacks and hoists of sufficient capacity for the job.

Never lubricate, service, or adjust machine while it is moving. Keep hands, feet, and clothing from power-driven moving and rotating parts. Disengage all power and operate controls to relieve pressure. Lower equipment to the ground, stop the engine. Remove the key. Wait for all moving parts to stop before servicing, adjusting, repairing or unplugging.

Securely support any machine elements with blocks or safety stands that must be raised for service work.

Keep all parts in good condition and properly installed. Fix damaged equipment immediately. Replace worn or broken parts. Remove any buildup of grease, oil, or debris.

Make sure all guards are in place and properly secured when maintenance work is completed.

Assembly

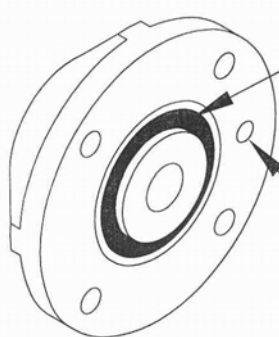

IF YOU CHOOSE TO LEAVE THE SEAL, THEN YOU NEED TO FILL CAVITY WITH GREASE. IF YOU CHOOSE TO REMOVE THE SEAL, THEN YOU NEED TO FILL CAVITY AND MAINTAIN THE GREASE EVERY 50 HOURS OF USE.

ALIGN GREASE FITTING HOLES.

I190-3

ALIGN THE HUB CAP GROOVE,
WITH THE WHEEL SLOT AND
GREASE FITTING

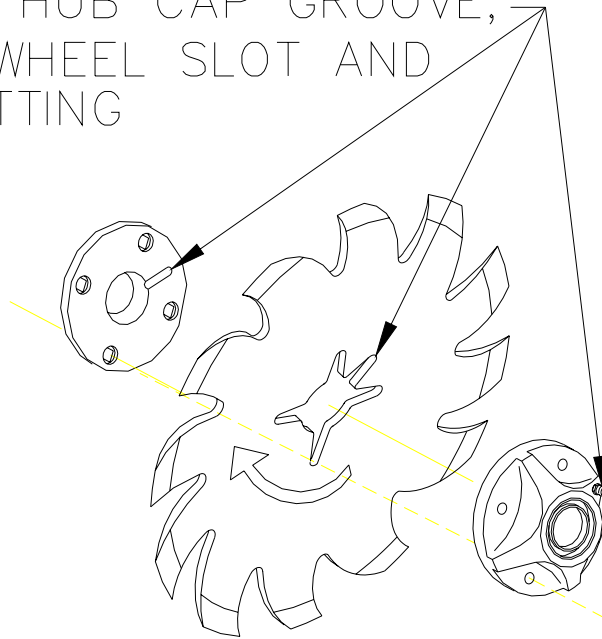

NOTE: Be certain to align the grease fitting with the slot in the wheel and the hubcap so that the grease can flow freely.

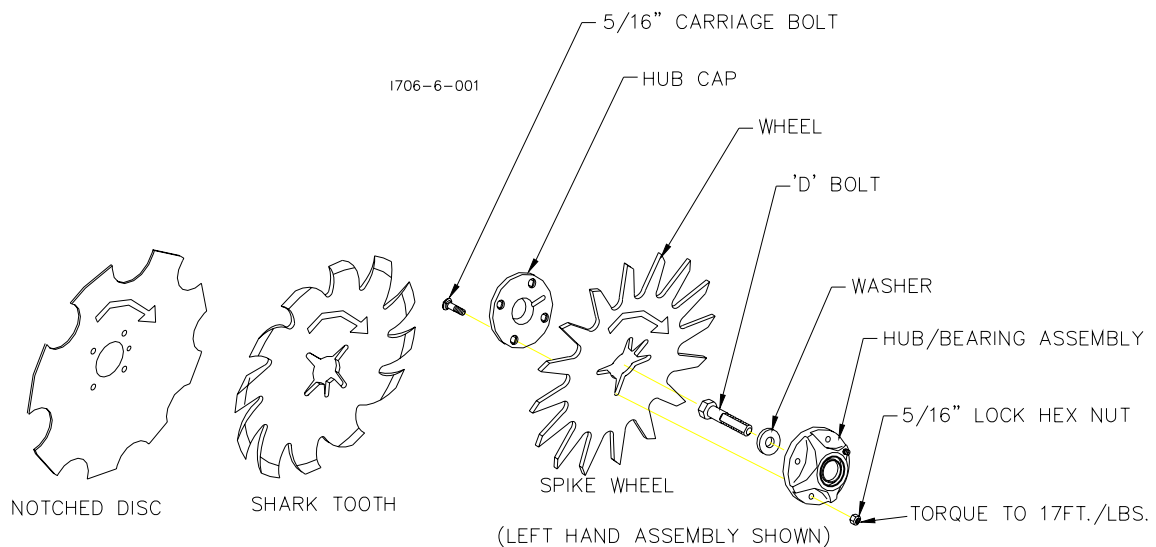

IMPORTANT: THE 2527-530 WASHER MUST BE INSTALLED OR THE WHEEL AND HUB ASSEMBLY WILL FALL OFF DURING USE.

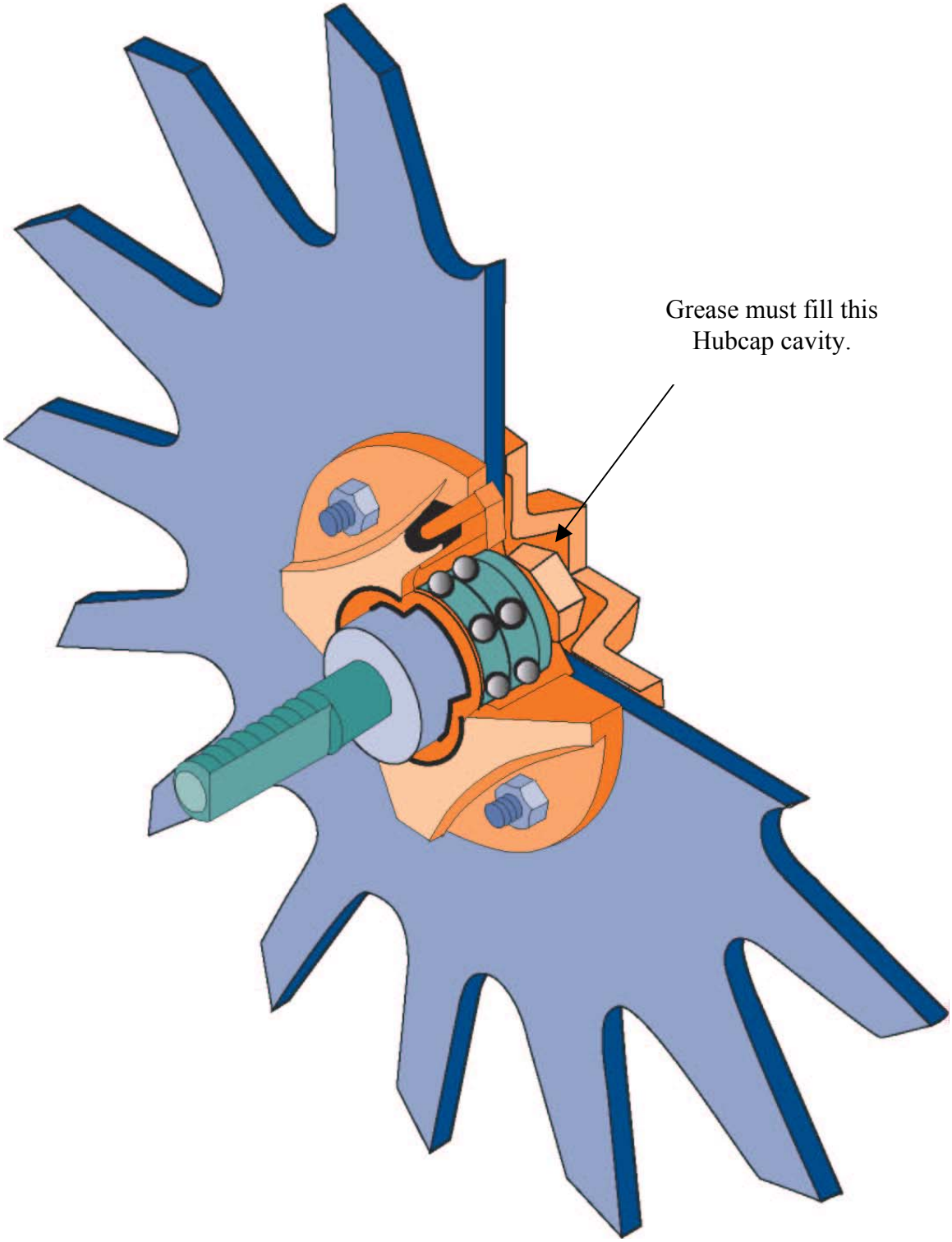

Grease must fill this
Hubcap cavity.

Lubrication



CAUTION: To help prevent serious injury or death to you or others caused by unexpected movement, service machine on a level surface. Lower machine to ground or sufficiently lock or block raised machine before servicing. If machine is connected to tractor, engage parking brake and place transmission in "PARK", shut off engine and remove key. If machine is detached from tractor, block wheels and use shop stands to prevent movement.



CAUTION: Do not clean, lubricate, or adjust machine while in motion.

Use grease based on NLGI consistency numbers and the expected air temperature range during the service interval.

Use a **multi-purpose lithium, water resistant, moderate speed, and NLGI grade #2** grease.

Other greases may be used if they meet the following **NLGI Performance Classification: GC-LB**

IMPORTANT: Some types of grease thickener are not compatible with others. Consult your grease supplier before mixing different types of grease.

Alternative Lubricants

Conditions in certain geographical areas may require special lubricants and lubrication practices which do not appear in the operator's manual. If there are any questions, consult Yetter Manufacturing Co. to obtain latest information and recommendation.

PART #	DESCRIPTION	OUNCES OF GREASE
2967-404	13" TAPER TOOTH R.M. WHEEL	1.12 OZ
2967-602	13" SHARK TOOTH R.M. WHEEL	1.12 OZ
2967-186	FLOATER WHEEL KIT W/R.M. WHEEL	2.08 OZ
2967-596	HEAVY DUTY OR BEVEL R.M. WHEEL W/ FLOATER WHEEL KIT	2.40 OZ

Storing Lubricants

Your machine can operate at top efficiency only if clean lubricants are used.

Use clean containers to handle all lubricants.

Store them in an area protected from dust, moisture and other contaminants.

Lubrication Symbols



Lubricate with grease at hourly interval indicated on symbol.

Lubrication Intervals

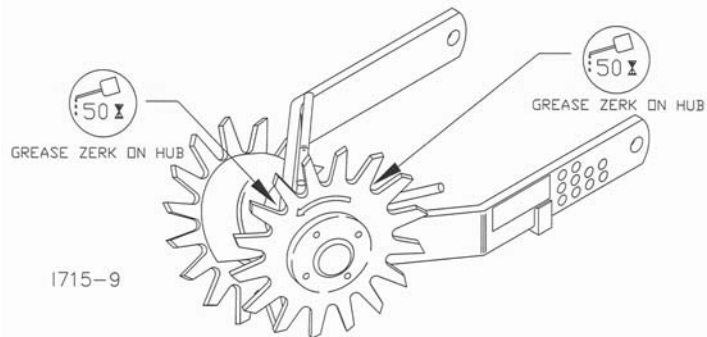

IMPORTANT: The recommended service intervals are based on normal conditions; severe or unusual conditions may require more frequent lubrication.

Perform each lubrication and service procedure at the beginning and end of each season.

Clean grease fittings before using grease gun, to avoid injecting dirt and grit into the bearing. Replace any lost or broken fittings immediately. If a fitting fails to take grease, remove and clean thoroughly, replace fitting if necessary. Also check for failure of adjoining parts.

BEARING REPLACEMENT INSTALLATION

1. If you wish to be able to grease the bearings in the hubs, remove the seal from one side of the bearings as illustrated before assembly. Otherwise the bearings may be left "sealed for life".
2. When assembling the spoke wheels, bearing assembly and hubcap, be sure to align the grease transfer hole in the spoke wheel with the groove in the hubcap and hole in the hub to allow grease passage.
3. Install/assemble the wheels, hubs and caps. **IMPORTANT: THE 2527-530 WASHER MUST BE INSTALLED OR THE WHEEL AND HUB ASSEMBLY WILL FALL OFF DURING USE.**
4. Grease the wheel/hub/bearing assembly.

Storing the Equipment

Store the machine in an area away from human activity

Store machine in RAISED position.

Install service locks on all wheel cylinders.

At the end of the season, the machine should be thoroughly inspected and prepared for storage. Repair or replace any worn or damaged components to prevent down time at the start of the next season. Store machine under cover with all parts in operating condition.

- Clean machine thoroughly to remove all dirt, debris and crop residue, which would hold moisture and cause rusting.
- Inspect machine for worn or broken parts. See your Yetter Farm Equipment dealer during the off-season so that parts or service can be acquired when machine is not needed in the field.
- Lubricate bearings as outlined in the Lubrication section
- Paint all parts which are chipped or worn and require repainting.
- Store machine in a clean, dry place with the planting unit out of the sun.
- If the machine cannot be stored inside, cover with a waterproof tarpaulin and tie securely in place.
- Do not allow children to play on or around the machine

YETTER MANUFACTURING CO.

FOUNDED 1930

Colchester, IL 62326-0358

Toll free: 800/447-5777

309/776-3222 (Fax)

Website: www.yetterco.com

E-mail: info@yetterco.com

YETTER