



6200 SERIES N-KEEPER™

6200-060B, 6200-062A

SET UP AND PARTS MANUAL

2565-956_Rev_E – 02/2023



YETTER MANUFACTURING CO.
FOUNDED 1930

Colchester, IL 62326-0358

Toll free: 800/447-5777

309/776-3222 (Fax)

Website: www.yetterco.com

E-mail: info@yetterco.com

YETTER

FOREWORD

You've just joined an exclusive but rapidly growing club.

For our part, we want to welcome you to the group and thank you for buying a Yetter product.

We hope your new Yetter products will help you achieve both goals-increase your productivity and increase your efficiency so that you may generate more profit.

This operator's manual has been designed into four major sections: Foreword, Safety Precautions, Installation Instructions and Parts Breakdown.



This **SAFETY ALERT SYMBOL** indicates important safety messages in the manual. When you see this symbol, be alert to the possibility of **PERSONAL INJURY** and carefully read the message that follows.

The word **NOTE** is used to convey information that is out of context with the manual text. It contains special information such as specifications, techniques and reference information of a supplementary nature.

The word **IMPORTANT** is used in the text when immediate damage will occur to the machine due

to improper technique or operation. Important will apply to the same information as specified by note only of an immediate and urgent nature.

It is the responsibility of the user to read the operator's manual and comply with the safe and correct operating procedure and to lubricate and maintain the product according to the maintenance schedule in the operator's manual.

The user is responsible for inspecting his machine and for having parts repaired or replaced when continued use of the product would cause damage or excessive wear to the other parts.

It is the user's responsibility to deliver his machine to the Yetter dealer who sold him the product for service or replacement of defective parts, which are covered by the warranty policy.

If you are unable to understand or follow the instructions provided in this publication, consult your local Yetter dealer or contact:

YETTER MANUFACTURING CO.

309/776-4111

800/447-5777

309/776-3222 (FAX)

Website: www.yetterco.com

E-mail: info@yetterco.com

WARRANTY

Yetter Manufacturing warrants all products manufactured and sold by it against defects in material. This warranty being expressly limited to replacement at the factory of such parts or products as shall appear to be defective after inspection. This warranty does not obligate the Company to bear cost of labor in replacement of parts. It is the policy of the Company to make improvements without incurring obligations to add them to any unit already sold. No warranty is made or authorized to be made, other than herein set forth. This warranty is in effect for one year after purchase.

DEALER: _____

Yetter Manufacturing warrants its own products only and cannot be responsible for damages to equipment on which mounted.



BE ALERT! YOUR SAFETY IS INVOLVED.



WATCH FOR THIS SYMBOL. IT POINTS OUT IMPORTANT SAFETY PRECAUTIONS. IT MEANS “ATTENTION---BECOME ALERT!”

It is your responsibility as an owner, operator, or supervisor to know and instruct everyone using this machine at the time of initial assignment and at least annually thereafter, of the proper operation, precautions, and work hazards which exist in the operation of the machine in accordance with OSHA regulations.

Safety Is No Accident

The following safety instructions, combined with common sense, will save your equipment from needless damage and the operator from unnecessary exposure to personal hazard. Pay special attention to the caution notes in the text. Review this manual at least once each year with new and/or experienced operators.



1. Read and understand the operator's manual before operating this machine. Failure to do so is considered a misuse of the equipment.
2. Make sure equipment is secure before operating.
3. Always keep children away from equipment when operating.
4. Make sure everyone that is not directly involved with the operation is out of the work area before beginning the operation.
5. Make sure all safety devices, shields, and guards are in place and are functional before beginning the operation.
6. Shut off power to adjust, service, or clean.
7. Keep hands, feet, and clothing away from moving parts. It is a good idea to remove all jewelry before starting the operation.
8. Visually inspect the machine periodically during operation for signs of excessive vibration, loose fasteners, and unusual noises.

TABLE OF CONTENTS

FOREWORD	2
WARRANTY	2
SAFETY INFORMATION	3
TORQUE	5
MAINTENANCE	6-8
ADJUSTMENTS	9-10
PART IDENTIFICATION	
6200-060B-L/R	11
6200-062A-L/R	12
6200-167-L/R	13
6200-115	14
2966-117-ST & 2966-116-ST	15-17
6200-161..... Yetter 2995 & 2996 Coulter	18
6200-162..... Shield, CNH, DMI Yetter 2995-086 Pre 2016 Coulter ..	19
6200-163..... Clymer Liquid Knife Coulter	20
6200-165..... Clymer Liquid Injection Coulter	21
6200-166..... Yetter 2995-086 Xtreme Coulter 2016-Present	22
6200-124..... Blue Jet Coulter	23
6200-172..... Ag System Coulter	24
6200-175..... Blue Jet Hardware Kit	25
PHOTOS	26-27

BOLT TORQUE

Important: Over tightening hardware can cause as much damage as when under tightening. Tightening hardware beyond the recommended range can reduce its shock load capacity.





The chart below is a guide for proper torque. Use it unless a specified torque is called out elsewhere in the manual.

Torque is the force you apply to the wrench handle or the cheater bar, times the length of the handle or bar.

Use a torque wrench whenever possible.

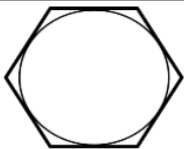

The following table shows torque in ft. lbs. for coarse thread hardware.

Bolt Diameter and Threads per Inch	 Grade 2	 Grade 5	 A-325	 Grade 8
1/4	6		10	14
5/16	12		20	30
3/8 – 16	25		35	50
7/16 – 14	35		55	80
1/2 – 13	55		85	125
9/16 – 12	75		125	175
5/8 – 11	105		170	235
3/4-10	185		305	425
7/8 – 9	170		445	690
1-8	260		670	1030
1 1/8 – 7	365		900	1460
1 1/4 - 7	515		1275	2060
1 3/8 – 6	675		1675	2700
1 1/2 - 6	900		2150	3500
1 3/4 – 5	1410		3500	5600

MAINTENANCE



Regularly inspect the 6200 N-Keeper™ system for loose or worn parts. Repair and replace as needed.

Lubrication



CAUTION: To help prevent serious injury or death to you or others, service machinery on a level surface. Lower machine to ground or sufficiently lock or block raised machine before servicing. If machine is connected to tractor, engage parking brake and place transmission in “PARK”, shut off engine and remove key. If machine is detached from tractor, block wheels and use jack stands to prevent movement.

CAUTION: Do not clean, lubricate, or adjust machine while in motion.

Use grease based on NLGI consistency number and the expected air temperature range during operation.

Use a **multi-purpose polyurea, water resistant, moderate speed, and NLGI grade #2** grease. Other greases may be used if they meet the **NLGI performance standard**.

IMPORTANT: Some types of grease thickener are not compatible with others. Consult your grease supplier before mixing different types of grease.

Alternative Lubricants

Conditions in certain geographical areas may require special lubricants and lubrication practices which do not appear in the operator’s manual. If there are any questions, consult Yetter Manufacturing Co. to obtain the latest information and recommendations.

Storing Lubricants

Your machine can operate at top efficiency only if clean lubricants are used. Use clean containers to handle all lubricants.

Store them in an area protected from dust, moisture, and other contaminants.

MAINTENANCE

Lubrication Intervals

Lubricate with grease at hourly interval indicated on symbol.

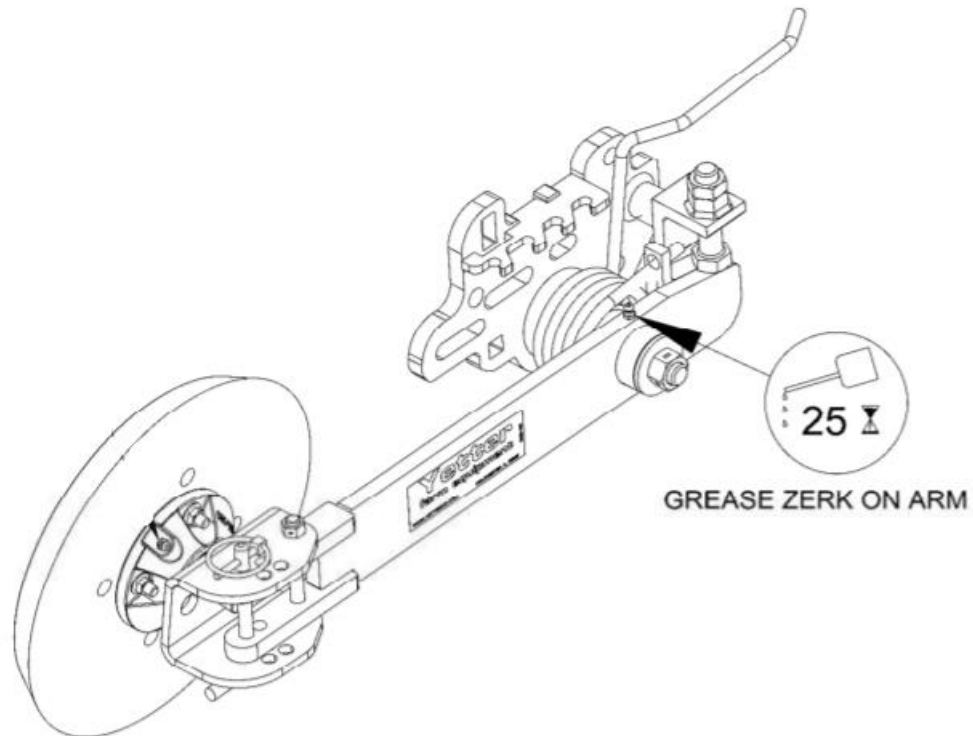

IMPORTANT: The recommended service intervals are based on normal operating conditions. Severe or unusual conditions may require more frequent lubrication.

Perform each lubrication and service procedure at the beginning and each of each season. Clean grease fittings before using grease gun to avoid injecting dirt and grit into the bearing. Replace and lost or broken fittings immediately. If a fitting fails to take grease, remove and clean thoroughly, replace if necessary. Also check for failure of adjoining parts.

MAINTENANCE

Storing the Equipment

Store the machine in an area away from human activity.

Store the machine in a RAISED position.

Install service locks on all wheel cylinders.

At the end of the season the machine should be thoroughly inspected and prepared for storage. Repair or replace any worn or damaged components to prevent down time at the beginning of the following season. Store machine under cover with all parts in operating condition.

- Clean machine thoroughly to remove all dirt, debris, and crop residue.
- Inspect machine for worn or broken parts. See your Yetter Farm Equipment dealer during the off-season so parts and service can be acquired when the machine is not needed in the field.
- Lubricate bearings as outlined in the lubrication section.
- Paint all parts which are chipped or worn to prevent rust.
- Store machine in a clean, dry location with the unit out of the sun.
- If the machine cannot be stored inside, cover with a waterproof tarpaulin and tie securely in place
- Do not allow children to play on or around the machine.

OPERATION ADJUSTMENTS

DOWNFORCE ADJUSTMENT

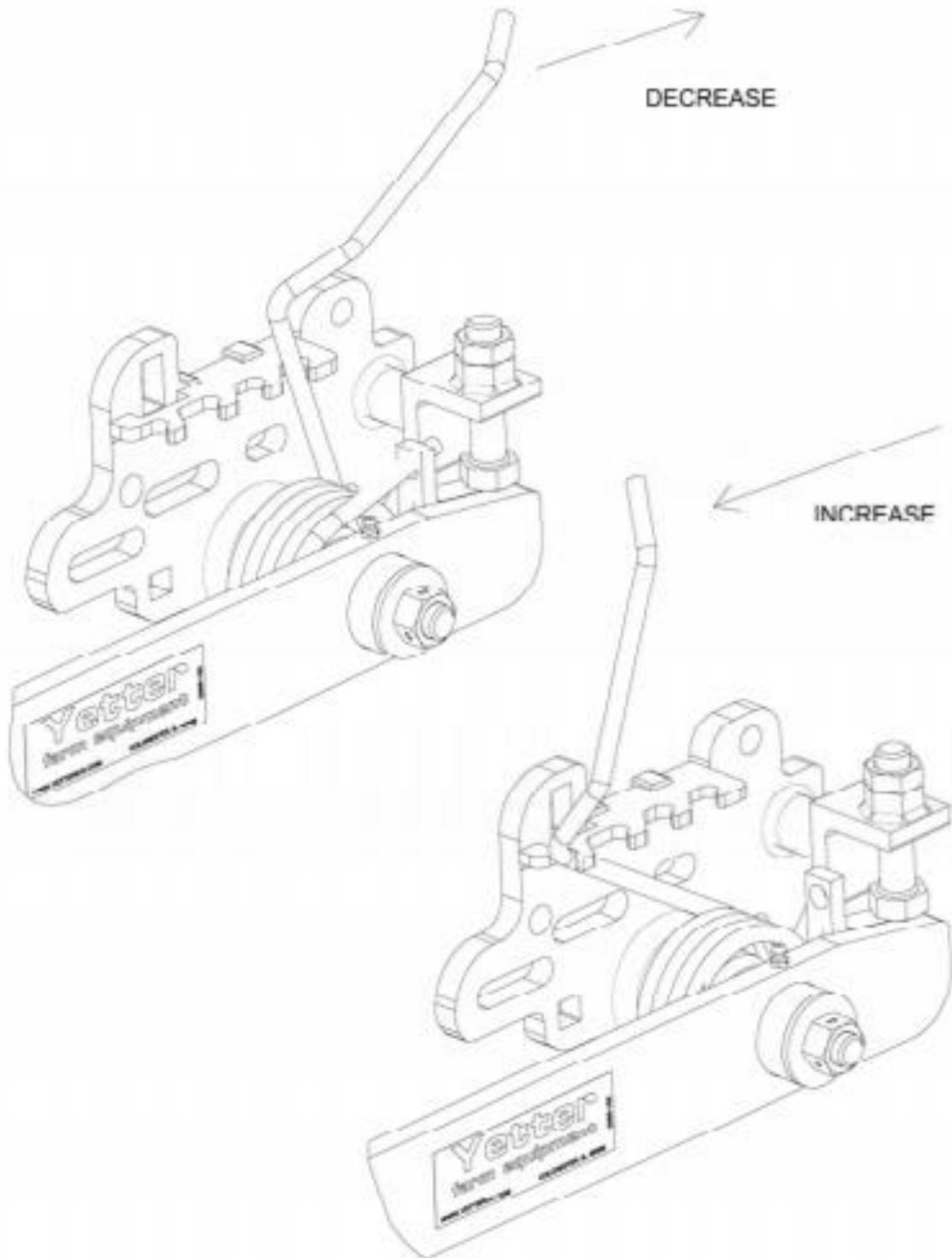

OPERATION ADJUSTMENTS

WHEEL ANGLE ADJUSTMENT

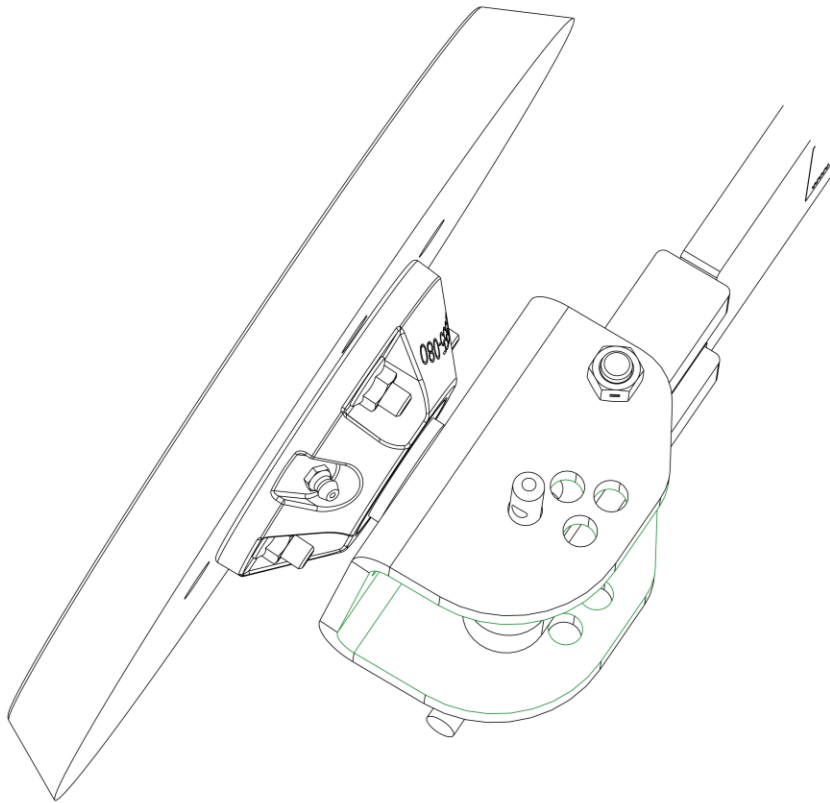
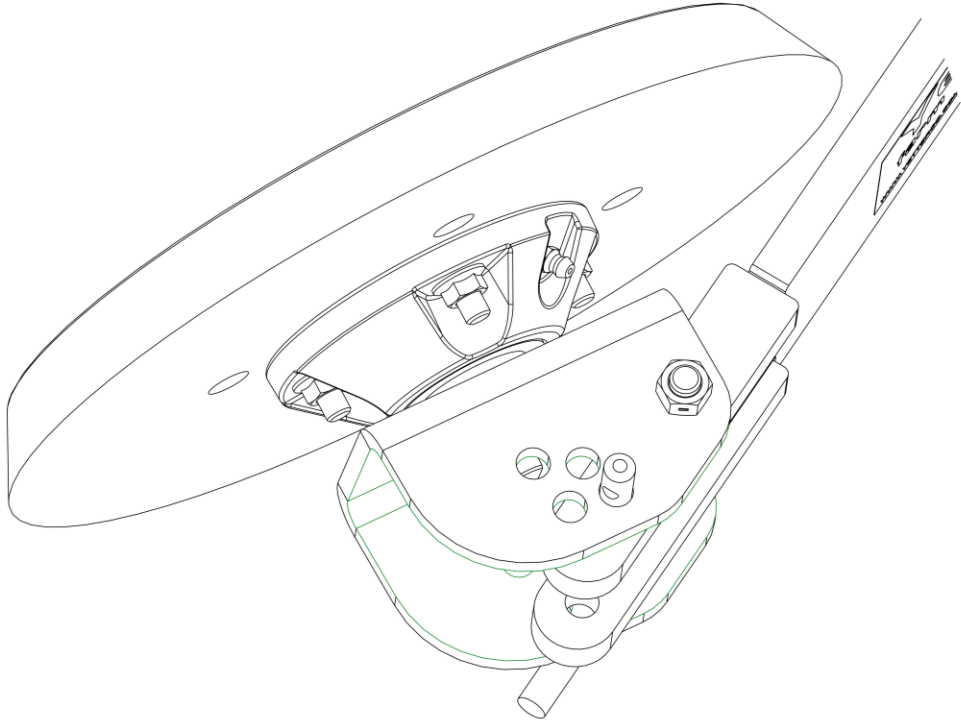

PART IDENTIFICATION

6200-060B-L CLOSING WHEEL ASSEMBLY

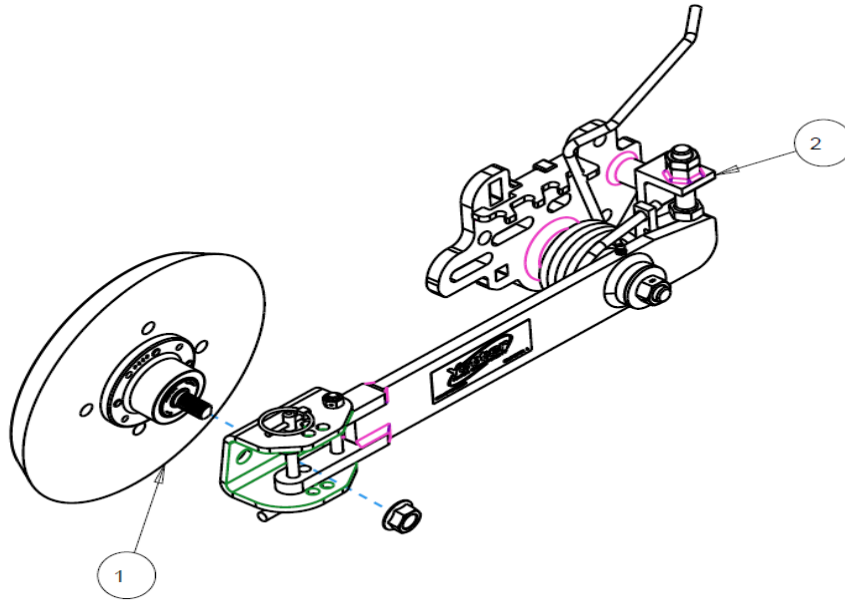

ITEM	PART NO	DESCRIPTION	QTY
1	6200-115	CAST CLOSING WHEEL ASSEMBLY	1
2	6200-167-L	LEFT HAND ARM ASSEMBLY	1
3	2520-465	5/8-11 FLANGE NUT GRADE 8	1

6200-060B-R CLOSING WHEEL ASSEMBLY

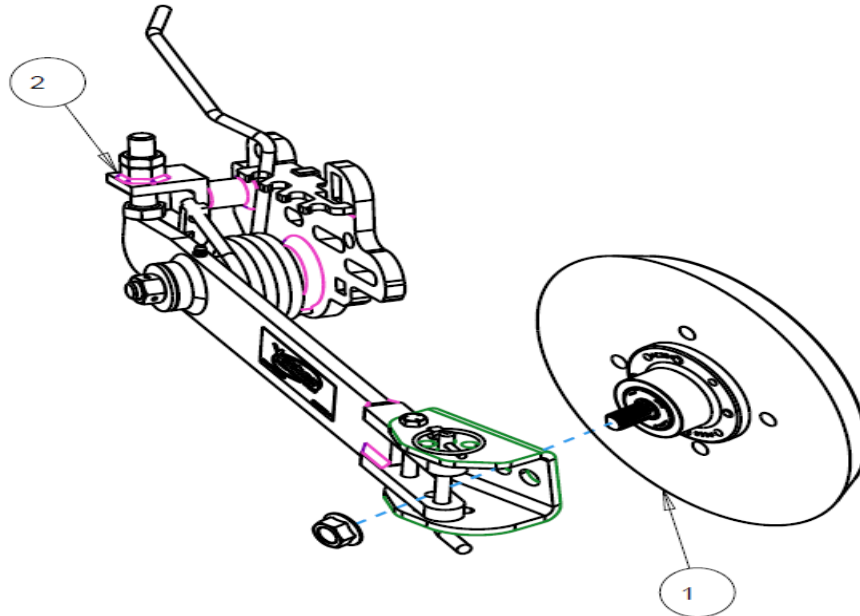

ITEM	PART NO	DESCRIPTION	QTY
1	6200-115	CAST CLOSING WHEEL ASSEMBLY	1
2	6200-167-R	RIGHT HAND ARM ASSEMBLY	1
3	2520-465	5/8-11 FLANGE NUT GRADE 8	1

PART IDENTIFICATION

6200-062A-L CLOSING WHEEL ASSEMBLY

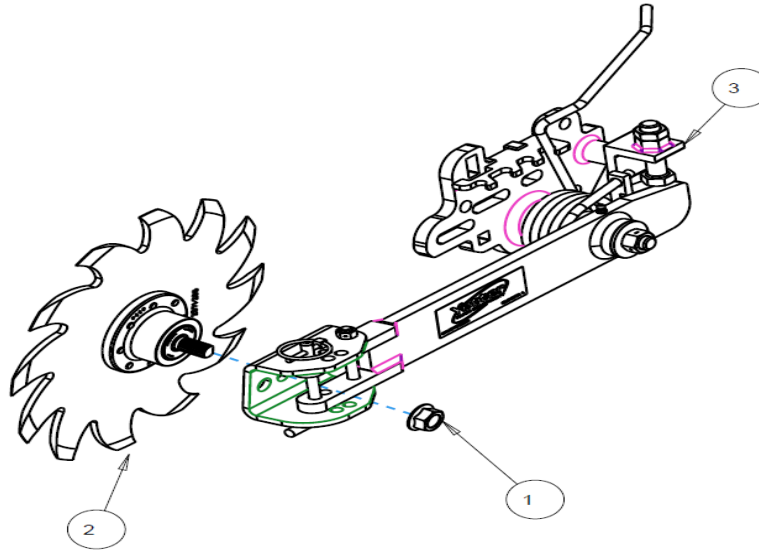

ITEM	PART NO	DESCRIPTION	QTY
1	2520-465	5/8-11 FLANGE NUT GRADE 8	1
2	2967-117-ST	L.H. SHARK TOOTH WHEEL ASSEMBLY	1
3	6700-167-L	LEFT HAND ARM ASSEMBLY	1

6200-062A-R CLOSING WHEEL ASSEMBLY

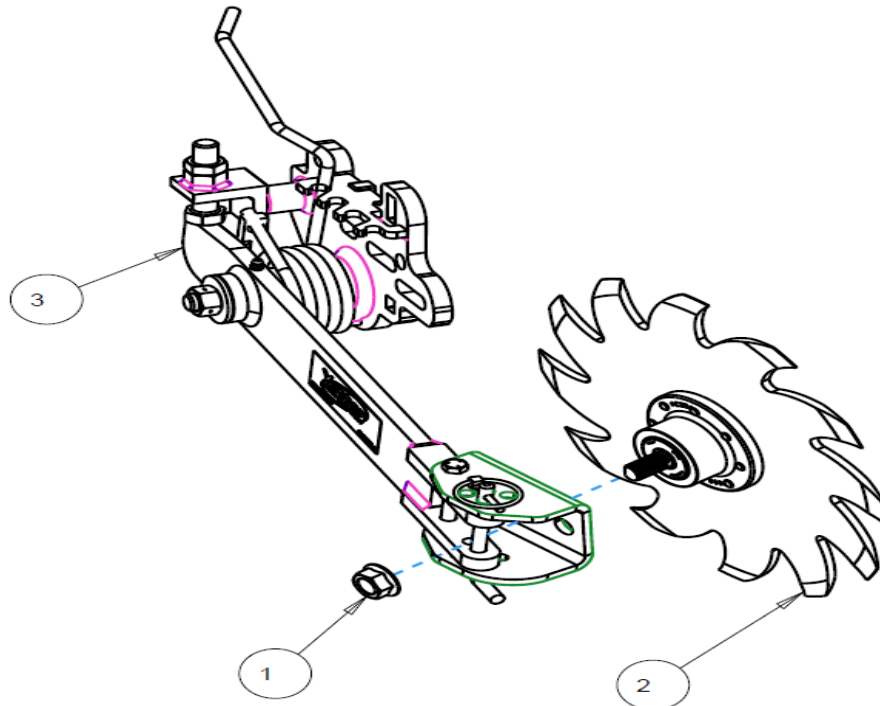

ITEM	PART NO	DESCRIPTION	QTY
1	2520-465	5/8-11 FLANGE NUT GRADE 8	1
2	2967-116-ST	R.H. SHARK TOOTH WHEEL ASSEMBLY	1
3	6700-167-R	RIGHT HAND ARM ASSEMBLY	1

PART IDENTIFICATION
6200-167-L
LH ASSEMBLY

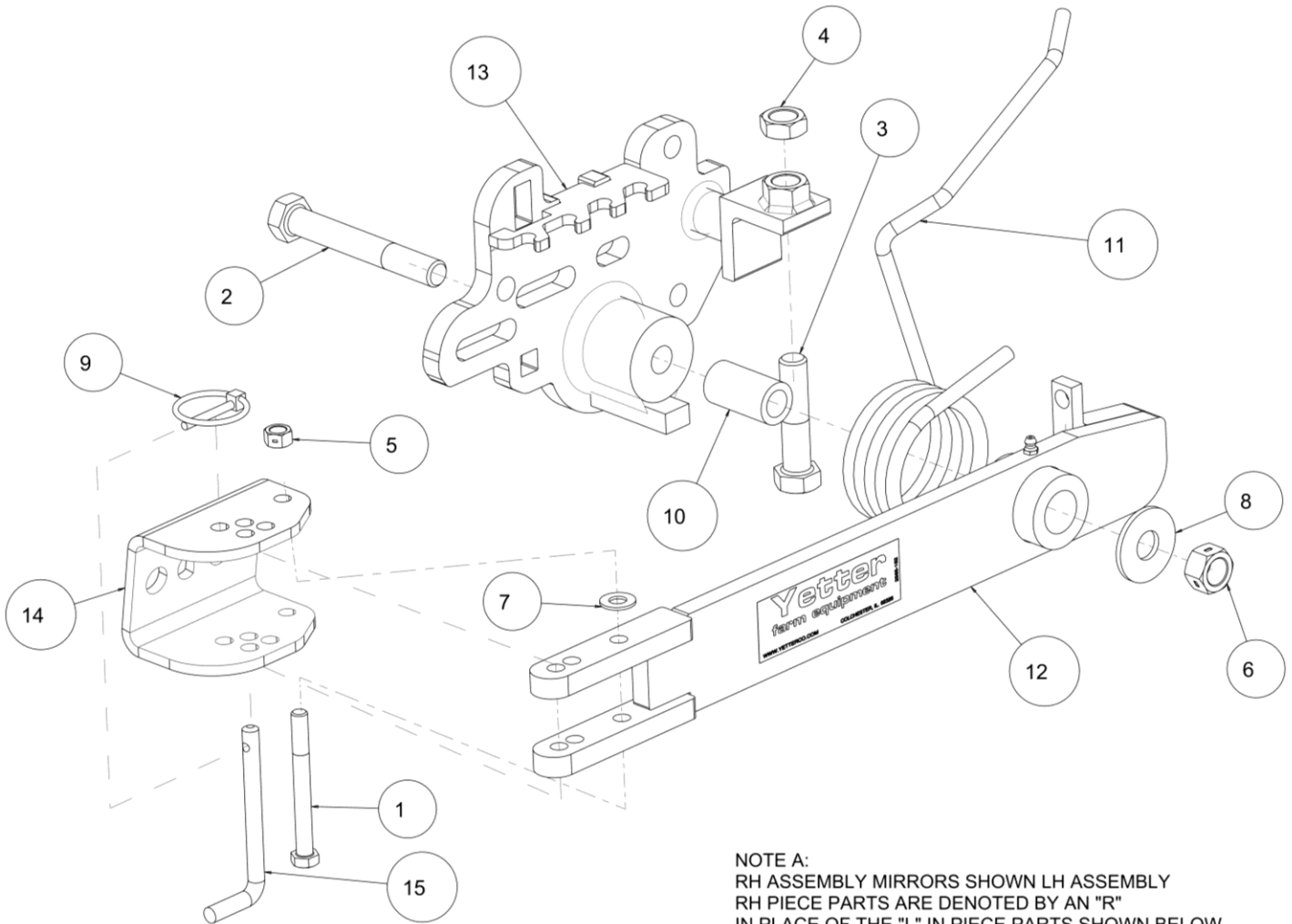

NOTE A:
 RH ASSEMBLY MIRRORS SHOWN LH ASSEMBLY
 RH PIECE PARTS ARE DENOTED BY AN "R"
 IN PLACE OF THE "L" IN PIECE PARTS SHOWN BELOW

ITEM	PART #	DESCRIPTION	QTY
1	2502-243	3/8- 16 X 3-1/2 HHCS GR 5	1
2	2502-334	5/8-11 X 4-1/2 HHCS GR5 ZP	1
3	2502-390	5/8-11 X 2-3/4 FL THD HHCS GR 5 ZP	1
4	2520-453	5/8-11 JAM HEX NUT ZP	1
5	2520-255	3/8-16 LOCK HEX NUT ZP	1
6	2520-459	5/8-11 LOCK HEX NUT, GR A, ZP	1
7	2526-253	3/8 SAE FLATWASHER ZP	1
8	2526-451	5/8 STD FLATWASHER ZP	1
9	2570-455	3/16 LYNCH PIN	1
10	2984-411	FRONT PVT BUSHING,FLT LNK, ZYD	1
(A)	11	2987-395-L PAINTED LH CLSNG ARM TORS SPRG	1
(A)	12	6200-168-L LH CLOSING WHEEL MACHINED	1
(A)	13	6200-235-L LH COULTER CLOSING MOUNT W.A.	1
(A)	14	6200-438-L LH WHEEL MOUNT	1
15	6200-439	3/8 X 1.313 X 3.95" BENT PIN, 90 DEG.	1

PART IDENTIFICATION

6200-115 WHEEL ASSEMBLY

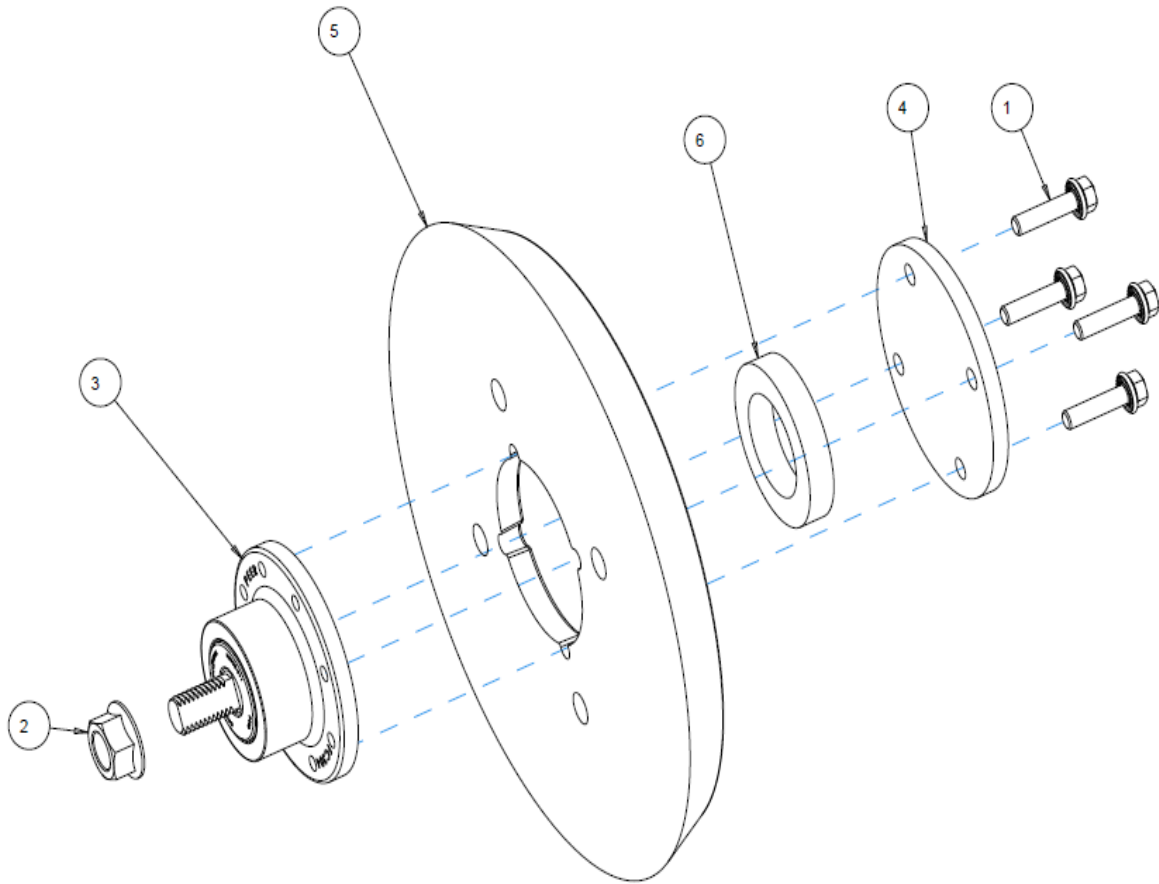

ITEM	PART NO	DESCRIPTION	QTY
1	2502-222	5/16-18 X 1-1/4 HHFS GRADE 5	1
2	2520-465	5/8-11 FLANGE NUT GRADE 8	1
3	2965-502	HUB ASSEMBLY 1.157 SPINDLE	1
4	2965-503	HUB CAP	1
5	2987-396	CAST WHEEL	1
6	6200-456	SPACER	1

PART IDENTIFICATION

2966-117-ST LEFT HAND WHEEL ASSEMBLY (SHOWN)
 2966-116-ST RIGHT HAND WHEEL ASSEMBLY

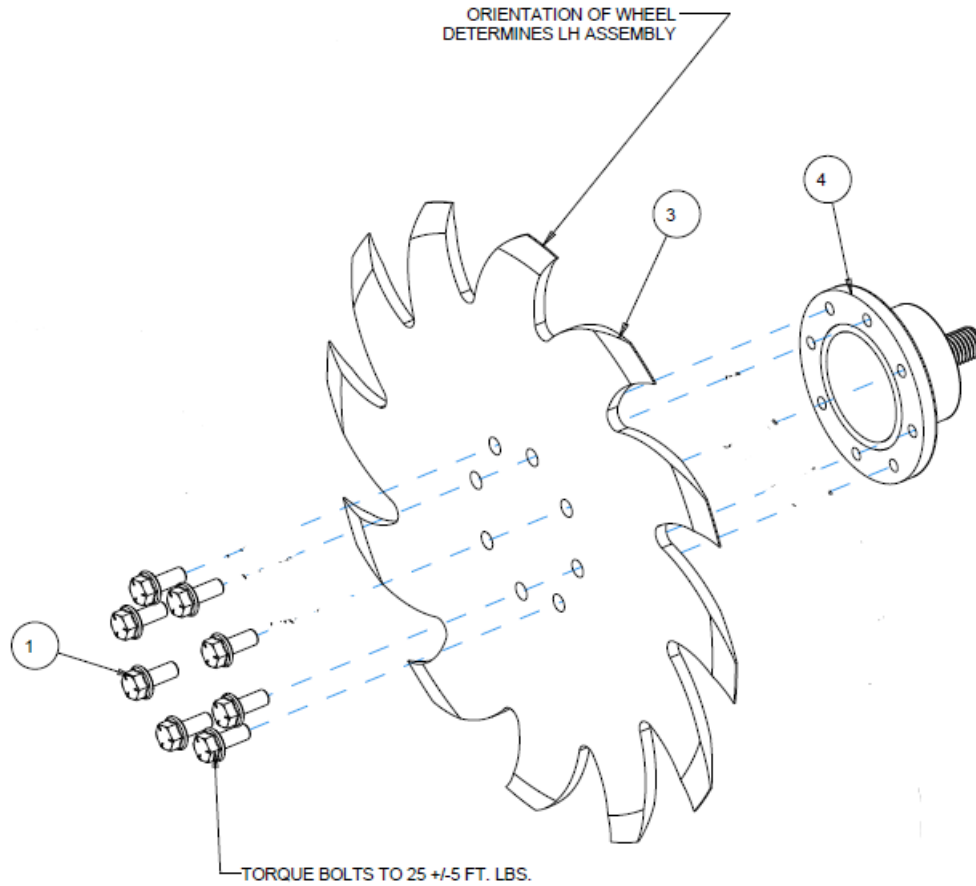

ITEM	PART NO.	DESCRIPTION	QTY
1	2502-220	5/16-18 X 3/4 HHFS GR5 ZP	8
2	2515-562	13" WHEEL COVER, BLACK	2
3	2571-286	SHARKTOOTH WHEEL, 8 BOLT	1
4	2965-502	HUB ASSEMBLY, 1.157 SPINDLE	1

MANUFACTURED 06/2021 – PRESENT

PART IDENTIFICATION
2966-117-ST LH WHEEL ASSY (SHOWN)
2966-116-ST RH WHEEL ASSY

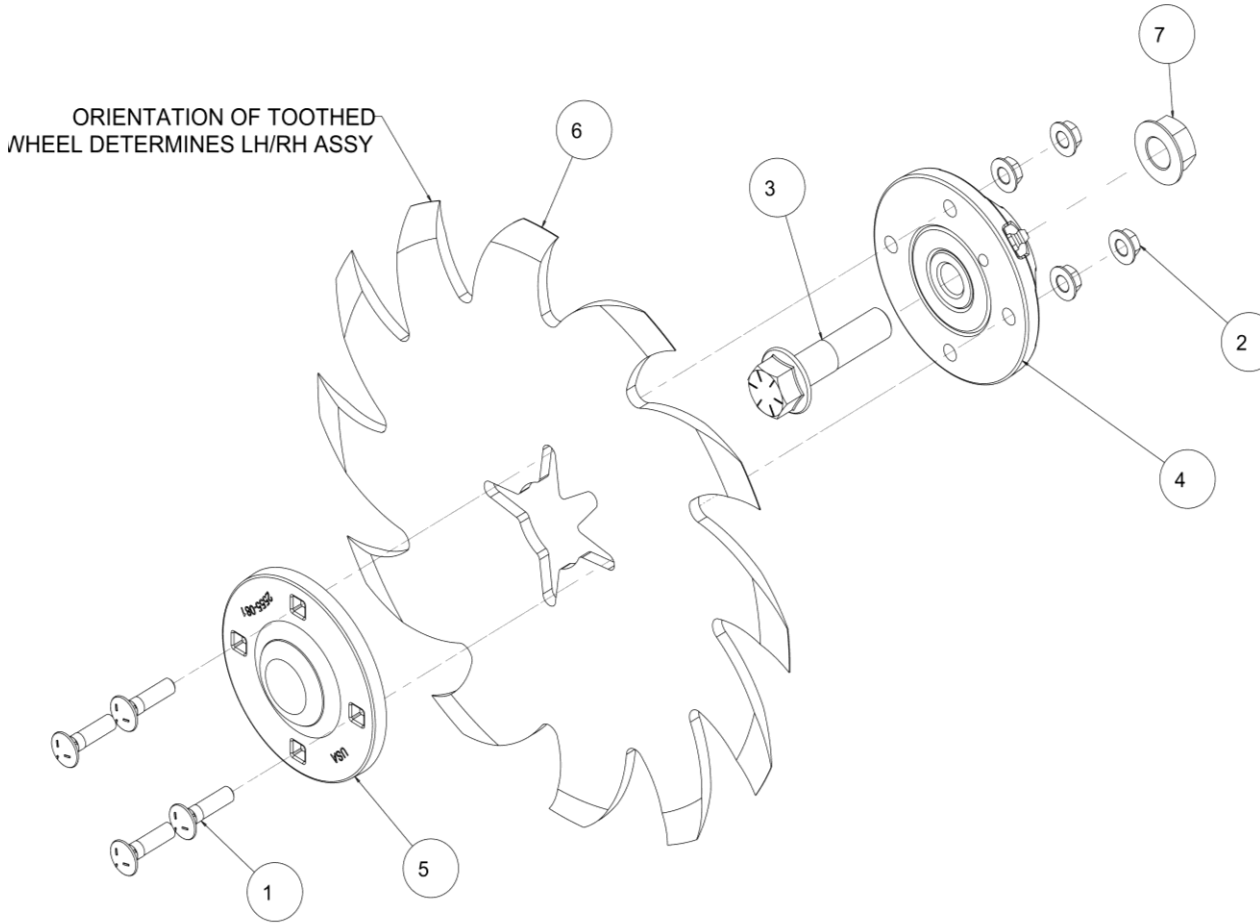

ITEM	PART NO	DESCRIPTION	QTY
1	2505-207	5/16-18 X 1-1/4 CARRIAGE HEAD BOLT GRADE 5	4
2	2520-206	5/16-18 FLANGE LOCK NUT	4
3	2570-766	D-BOLT FLANGE HEAD 5/8-11 X 2.562 GRADE 8	1
4	2965-128	HUB/BEARING ASSEMBLY	1
	2550-069	SEAL	1
	2570-594	BEARING	1
	2570-715	INSERT	1
	2965-351	HUB	1
	2533-110	GREASE FITTING	1
5	2965-352	HUB CAP	1
6	2967-602	SHARK TOOTH WHEEL	1
7	2520-465	5/8-11 FLANGE LOCK NUT GRADE 8	1

MANUFACTURED 06/2014 – 06/2021

FIELD SERVICE KITS

- 2965-119 - SERVICE KIT FOR 2570-740-2.812 D-BOLT
- 2965-120 - SERVICE KIT FOR 2570-742-3.812 D-BOLT
- 2965-121 - SERVICE KIT FOR 2570-766-2.562 D-BOLT

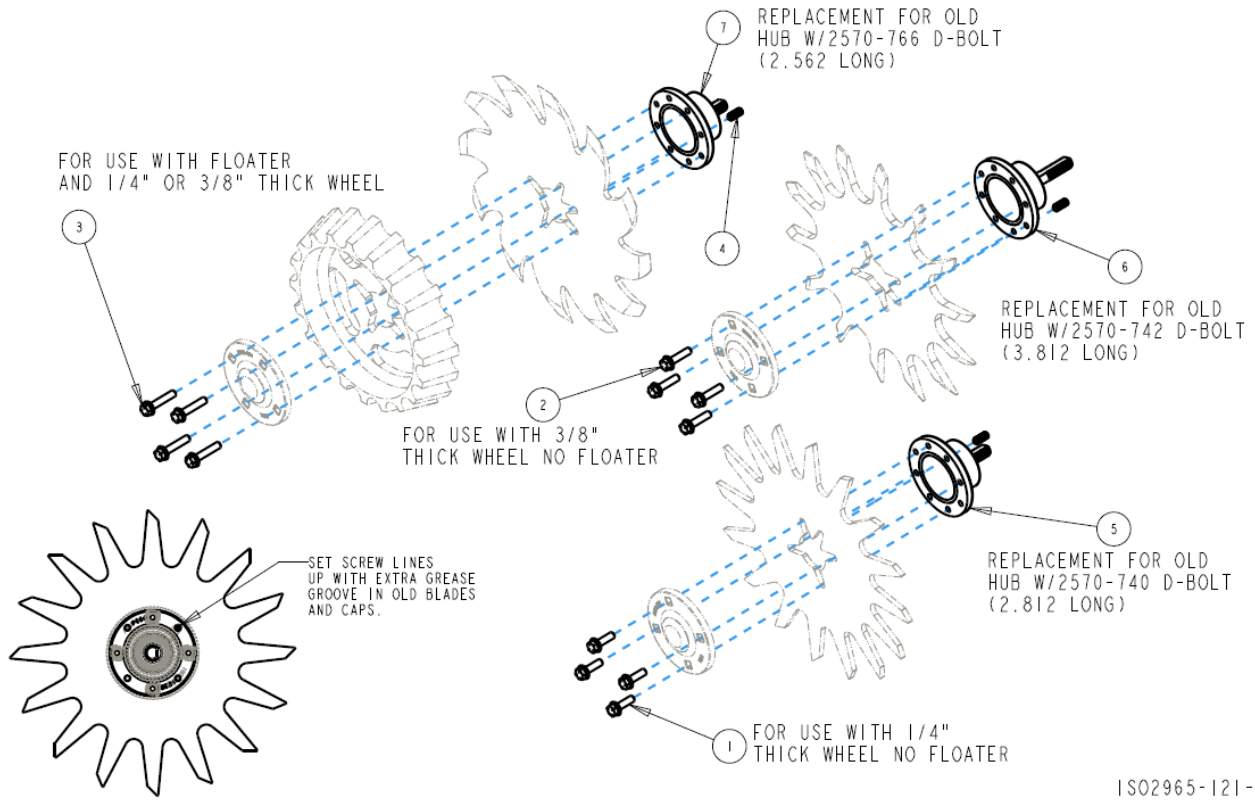

ISO2965-121-2

ITEM	PART NO	DESCRIPTION	QTY
1	2502-221	5/16-18 X 1 HHFS GRADE 5	4
2	2502-222	5/16-18 X 1-1/4 HHFS GRADE 5	4
3	2502-225	5/16-18 X 1-1/2 HHFS GRADE 5	4
4	2940-560	SET SCREW	1
5	2965-500	HUB ASSEMBLY 1.406 SPINDLE	1
6	2965-501	HUB ASSEMBLY 2.406 SPINDLE	1
7	2965-502	HUB ASSEMBLY 1.157 SPINDLE	1

PART IDENTIFICATION

6200-161 MOUNT HARDWARE FOR YETTER 2995/2996/GEN III COULTER

DIFFERENT BOLT TYPES AND LENGTHS
WILL BE USED HERE
BASED ON KNIFE OFFSET AND ATTACHMENT

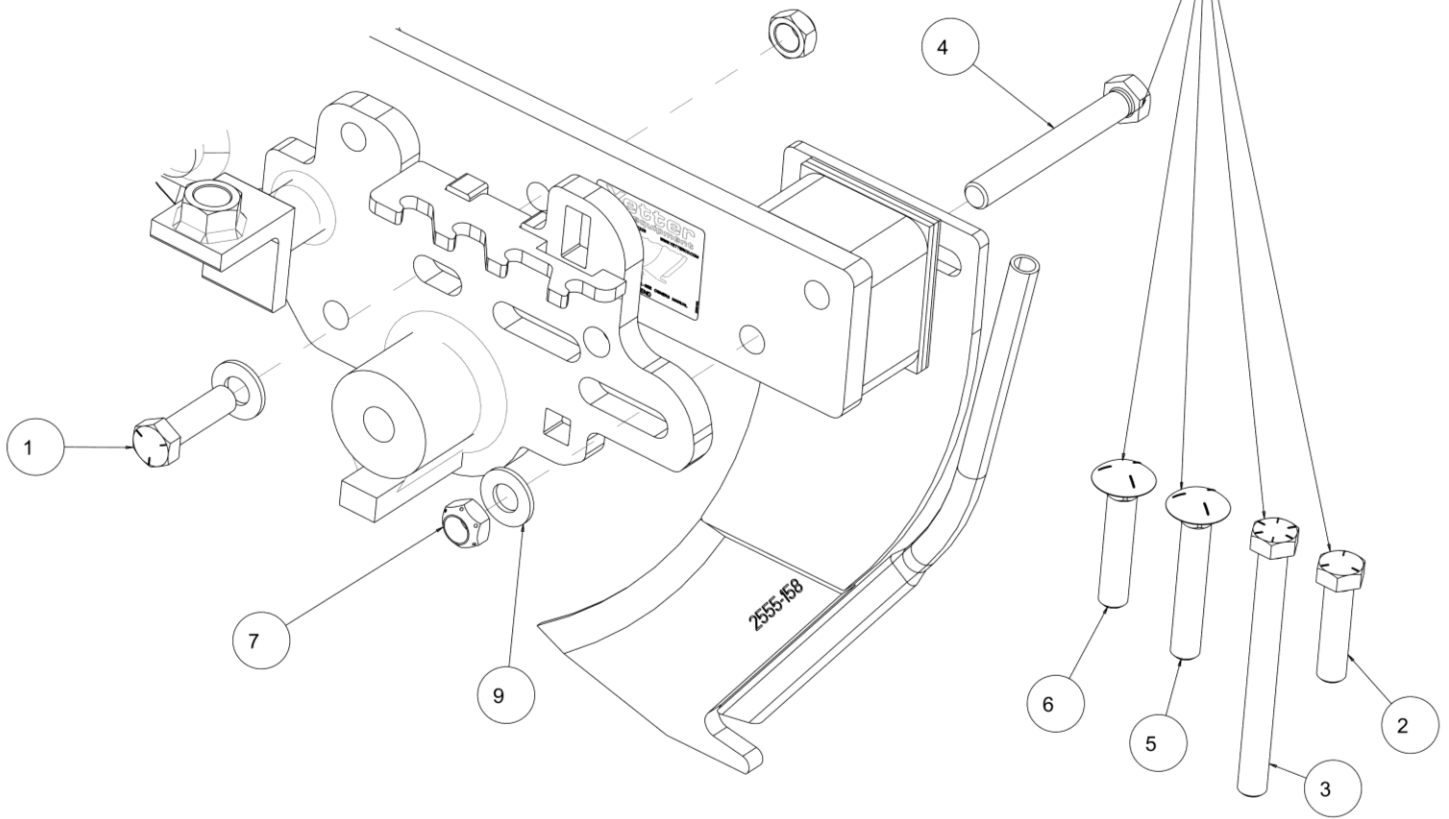

ITEM	PART #	DESCRIPTION	QTY
1	2502-317	1/2-13 X 1-3/4 HHCS GR5 ZP	1
2	2502-351	1/2-13 X 2 HHCS GR.5 ZP	1
3	2502-361	1/2-13 X 5 HHCS GR8 ZP	1
4	2502-364	1/2-13 X 4 HHCS GR. 5 ZP	1
5	2505-330	1/2-13 X 3 CARBLT G5ZP	1
6	2505-343	1/2-13 X 2 1/2 CAR.BLT.GR.5 ZP	1
7	2520-362	1/2-13 HEX LOK NUT, GR C, ZP	2
8	2520-464	5/8-11 WHIZLOCK HEX NUT, GR 2, ZP	1
9	2526-352	1/2 SAE FLATWASHER ZP	2

PART IDENTIFICATION

6200-162

MOUNT HARDWARE FOR 3" ARM YETTER 2995-086 XTREME (2015 & OLDER),
SHIELD, CNH, OR DMI COULTERS

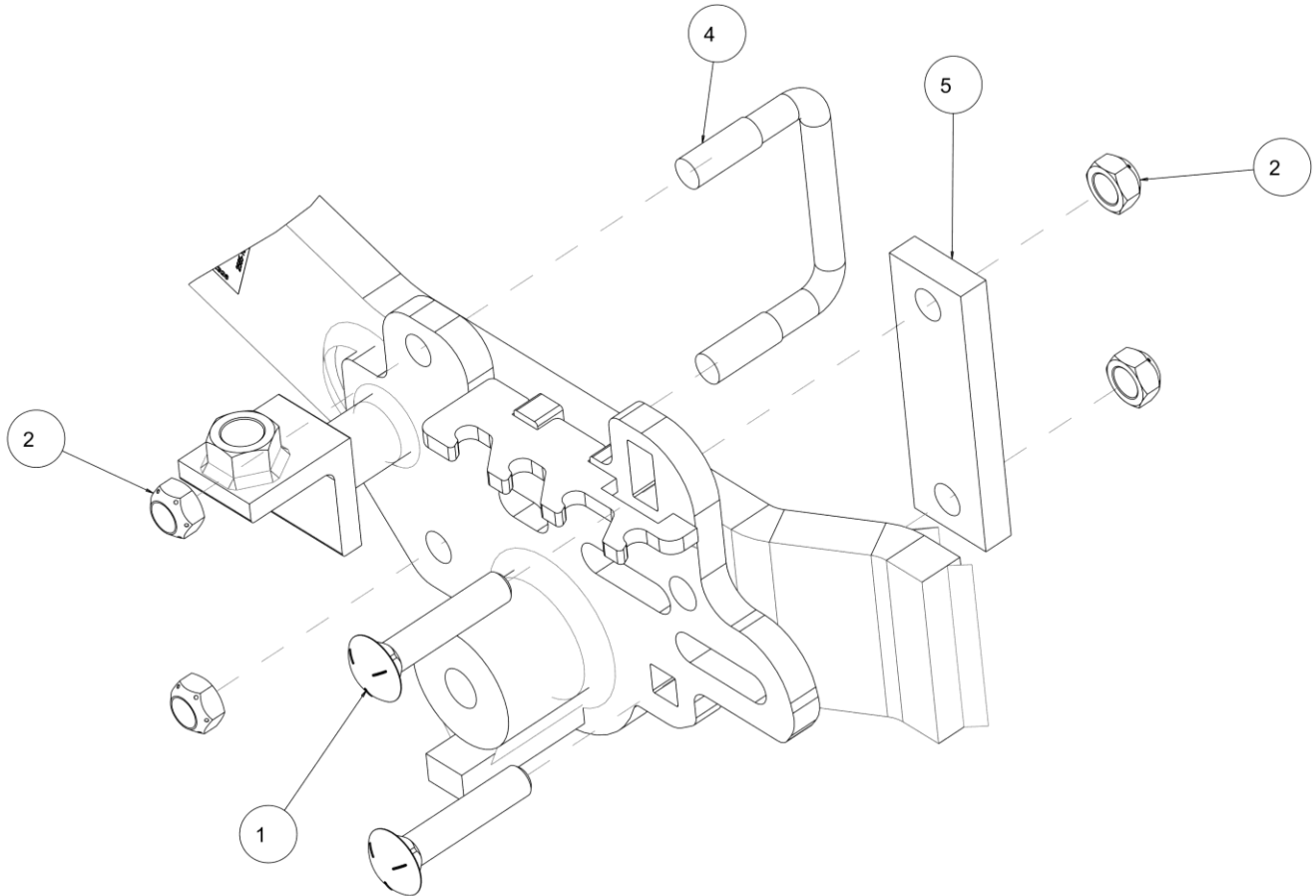

ITEM	PART #	DESCRIPTION	QTY
1	2505-343	1/2-13 X 2 1/2 CAR.BLT.GR.5 ZP	2
2	2520-362	1/2-13 HEX LOK NUT, GR C, ZP	4
3	2520-464	5/8-11 WHIZLOCK HEX NUT, GR 2, ZP	1
4	2570-736	1/2 X 3-1/8 X 2-1/4 U-BOLT	1
5	6200-444	3" CLAMP PLATE	1

PART IDENTIFICATION

6200-163 MOUNT HARDWARE FOR CLYMER LIQUID KNIFE SYSTEM

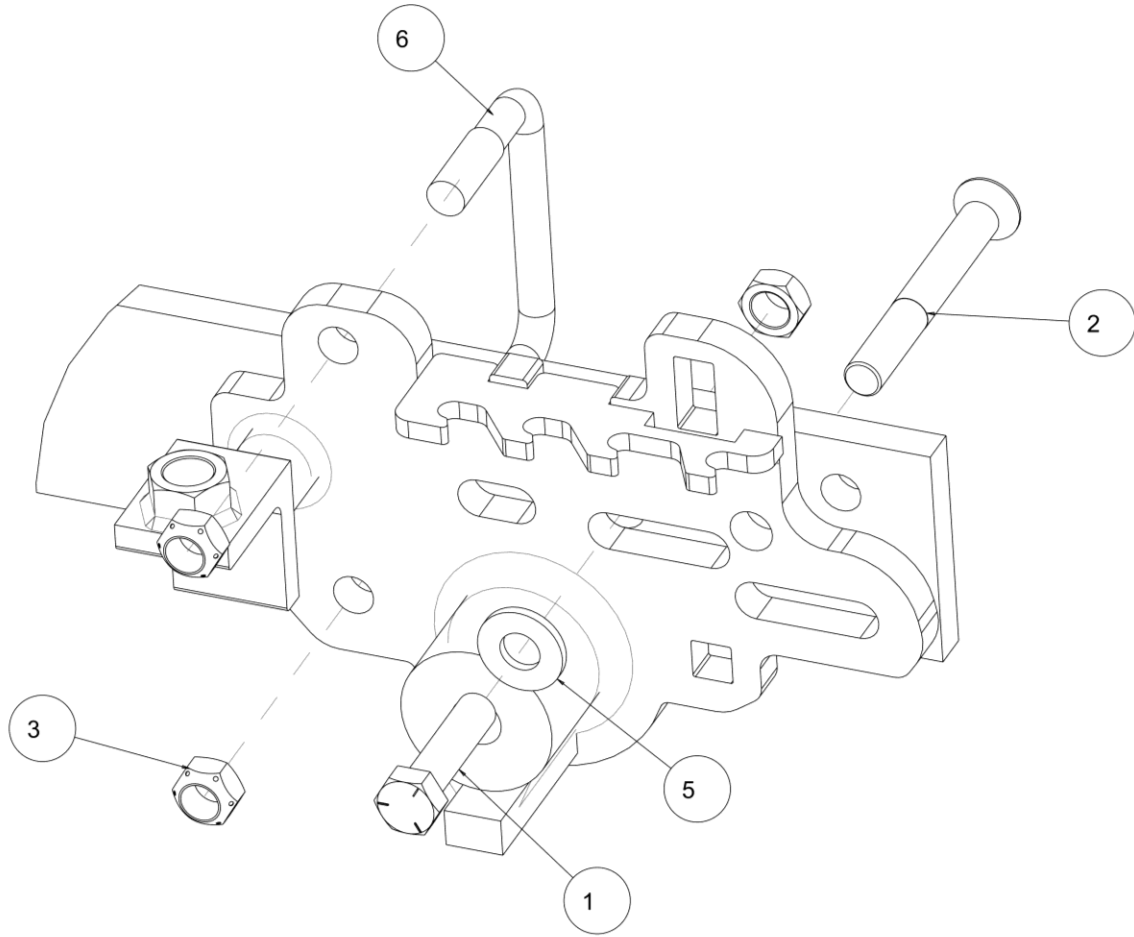

ITEM	PART #	DESCRIPTION	QTY
1	2502-351	1/2-13 X 2 HHCS GR.5 ZP	1
2	2502-360	1/2-13 X 4 HSFHCS	1
3	2520-362	1/2-13 HEX LOK NUT, GR C, ZP	3
4	2520-464	5/8-11 WHIZLOCK HEX NUT, GR 2, ZP	1
5	2526-355	1/2 FLAT WASHER HARD'ND ZP	1
6	2570-736	1/2 X 3-1/8 X 2-1/4 U-BOLT	1

PART IDENTIFICATION

6200-165 MOUNT HARDWARE AND ADAPTER PLATE FOR CLYMER LIQUID INJECTION SYSTEM

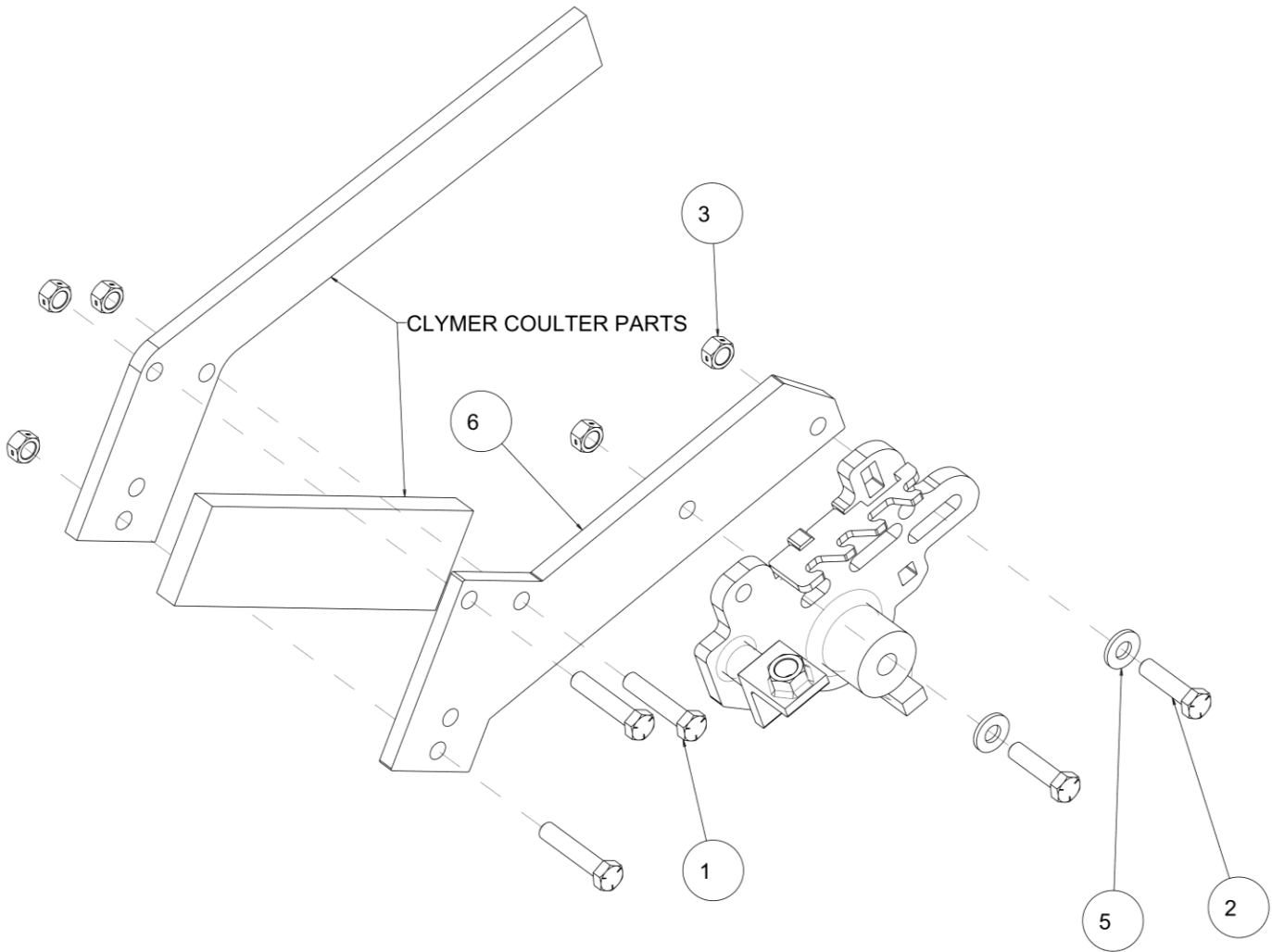

ITEM	PART #	DESCRIPTION	QTY
1	2502-296	1/2-13 X 2-1/2 HHCS GR5 ZP	3
2	2502-351	1/2-13 X 2 HHCS GR.5 ZP	2
3	2520-357	1/2-13 LOCK HEX NUT, GR A, ZP	5
4	2520-464	5/8-11 WHIZLOCK HEX NUT, GR 2, ZP	1
5	2526-355	1/2 FLAT WASHER HARD'ND ZP	2
6	6200-445	Adapter Plate Clymer to N-keeper	1

PART IDENTIFICATION

6200-166 MOUNT HARDWARE FOR YETTER 2995-086 XTREME (2016)

SHOWN HARDWARE WILL NOT BE USED IN THIS MOUNT CONFIGURATION

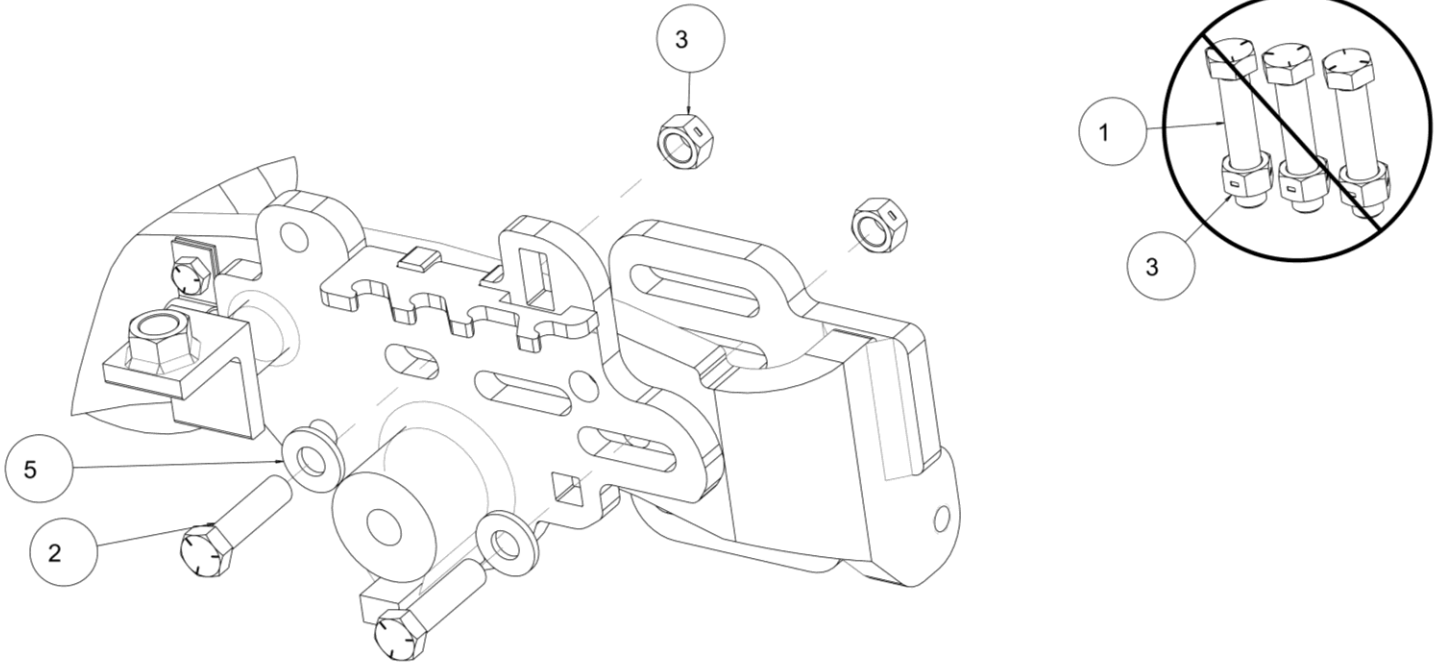

ITEM	PART #	DESCRIPTION	QTY
1	2502-296	1/2-13 X 2-1/2 HHCS GR5 ZP	3
2	2502-351	1/2-13 X 2 HHCS GR.5 ZP	2
3	2520-357	1/2-13 LOCK HEX NUT, GR A, ZP	5
4	2520-464	5/8-11 WHIZLOCK HEX NUT, GR 2, ZP	1
5	2526-355	1/2 FLAT WASHER HARD'ND ZP	2

PART IDENTIFICATION

6200-124

MOUNT HARDWARE FOR BLU JET COULTER LIQUID FERTILIZER SYSTEM

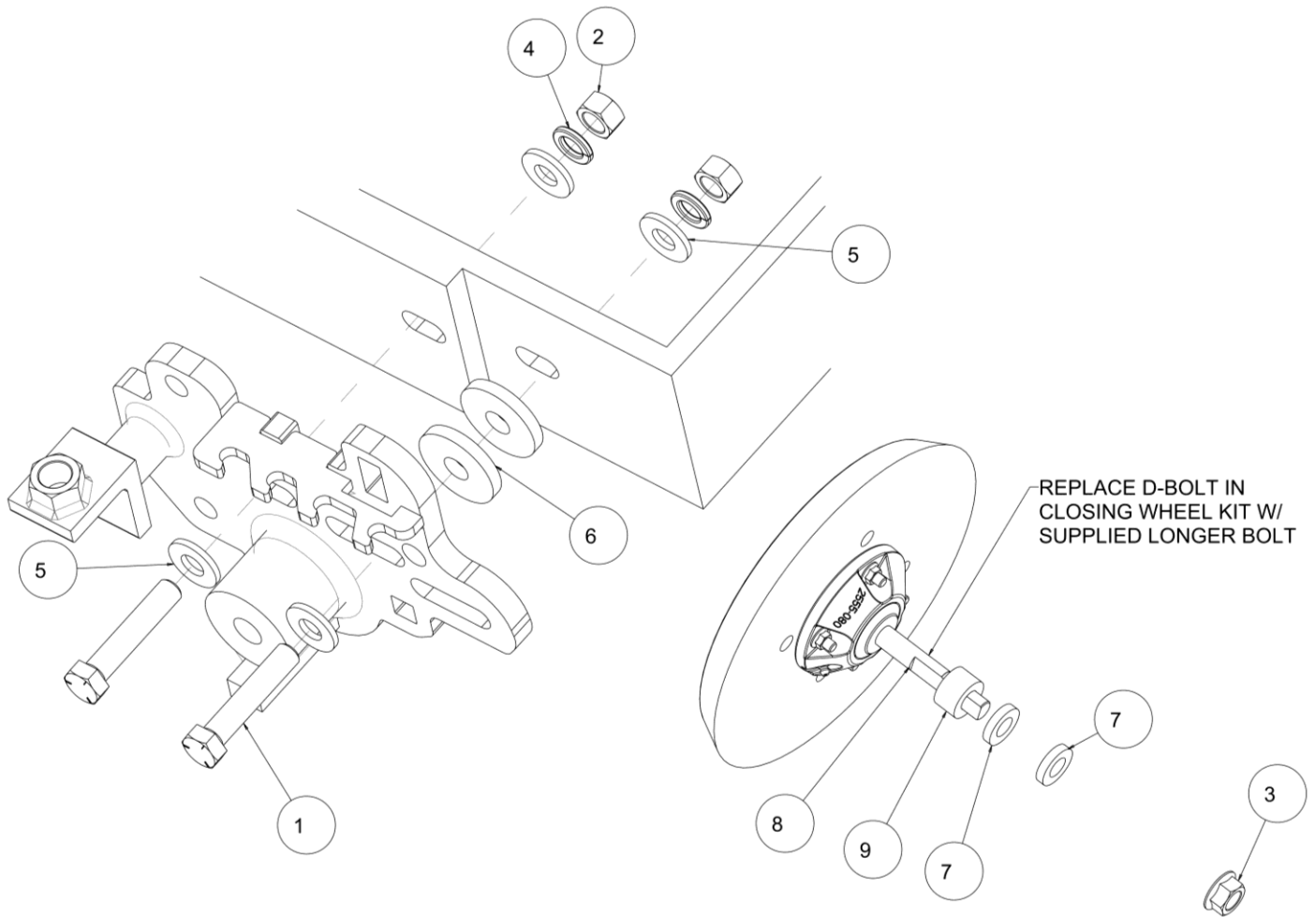

ITEM	PART #	DESCRIPTION	QTY
1	2502-296	1/2-13 X 2-1/2 HHCS GR5 ZP	2
2	2520-352	1/2-13 HEX NUT ZP	2
3	2520-464	5/8-11 WHIZLOCK HEX NUT, GR 2, ZP	1
4	2525-352	1/2 MED LOCKWASHER ZP.	2
5	2526-355	1/2 FLAT WASHER HARD'ND ZP	4
6	2526-402	9/16ID X 1-3/4 OD X 1/4MBZP	2
7	2526-455	WASH 21/32" X 1 1/4" X 1/4	2
8	2570-742	D-BOLT, FLGD, 5/8-11 X 3.812" GR8 ZP	1
9	2967-302	SPACER, 3/4" PLATED	1

PART IDENTIFICATION

6200-172-L (SHOWN) AND 6200-172-R MOUNT HARDWARE AND EXTENDED WHEEL MOUNT BASKET FOR AG SYSTEMS COULTER

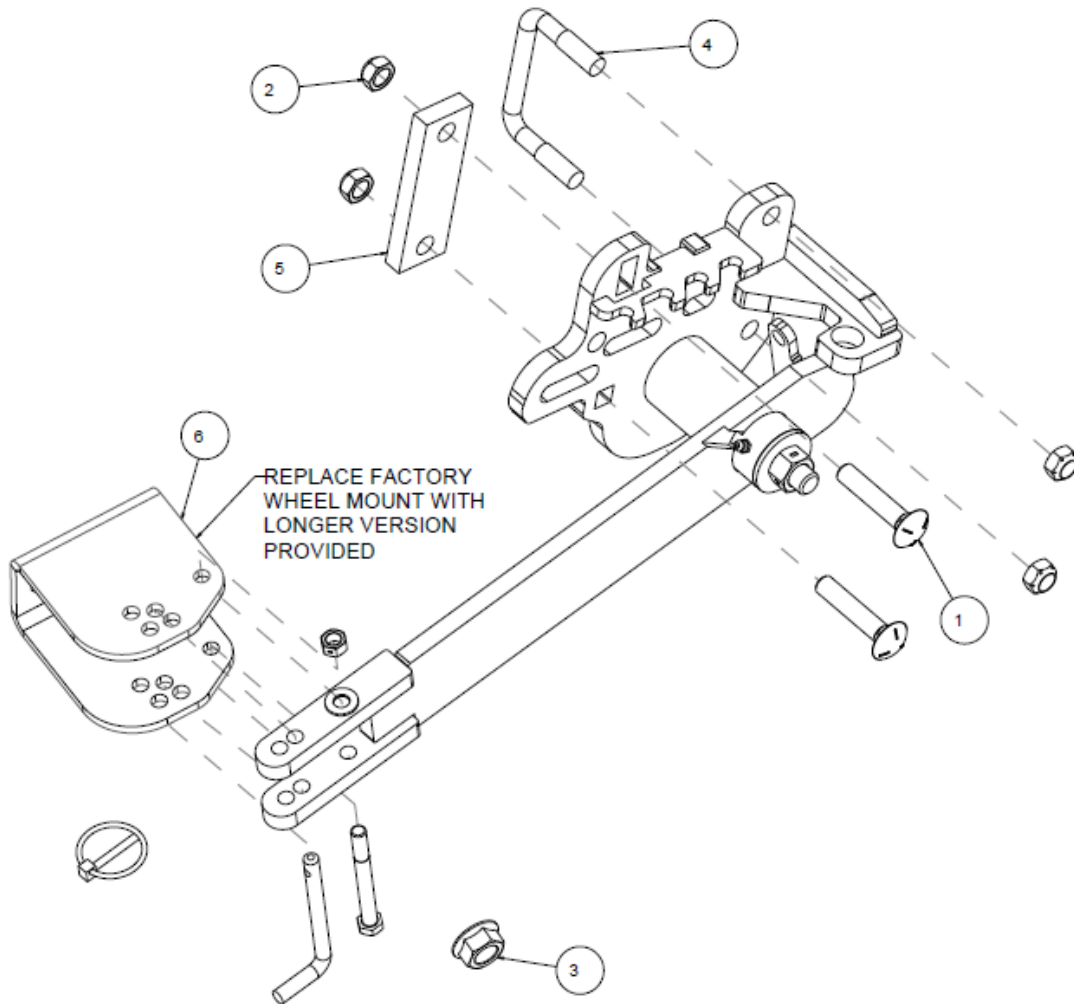

ITEM	PART #	DESCRIPTION	QTY
1	2505-343	1/2-13 X 2 1/2 CAR.BLT.GR.5 ZP	2
2	2520-362	1/2-13 HEX LOK NUT, GR C, ZP	4
3	2520-464	5/8-11 WHIZLOCK HEX NUT, GR 2, ZP	1
4	2570-736	1/2 X 3-1/8 X 2-1/4 U-BOLT	1
5	6200-444	3" CLAMP PLATE	1
6	6200-460-L	EXTENDED WHEEL MOUNT LH(SHOWN)	1
	6200-460-R	EXTENDED WHEEL MOUNT RH	1

PART IDENTIFICATION

6200-175

Mount Hardware for BLU JET Coulter

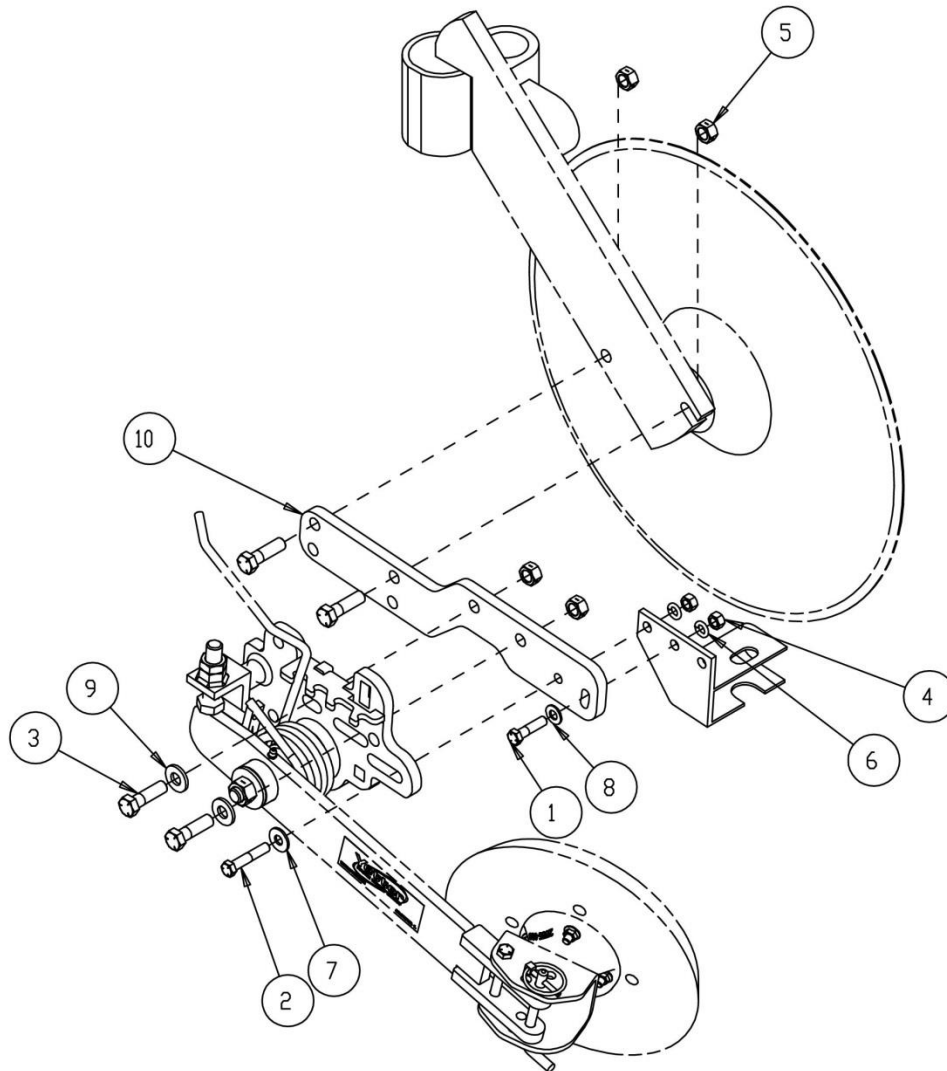

ITEM	PART NO.	DESCRIPTION	QTY
1	2502-232	3/8-16 X 1 1/2 HHCS GR 5 ZYD	1
2	2502-240	3/8-16 X 2 HHCS GR5 ZP	1
3	2502-317	1/2-13 X 1-3/4 HHCS GR5 ZP	4
4	2520-251	3/8-16 HEX NUT ZP	2
5	2520-357	1/2-13 LOCK HEX NUT, GR A, ZP	4
6	2525-251	3/8 MED. LOCKWASHER ZP.	2
7	2526-251	3/8 STANDARD FLATWASHER ZP	1
8	2526-253	3/8 SAE FLATWASHER ZP	1
9	2526-355	1/2 FLAT WASHER HARD'ND ZP	2
10	6200-473	MOUNT PLATE	1

PHOTO ALBUM

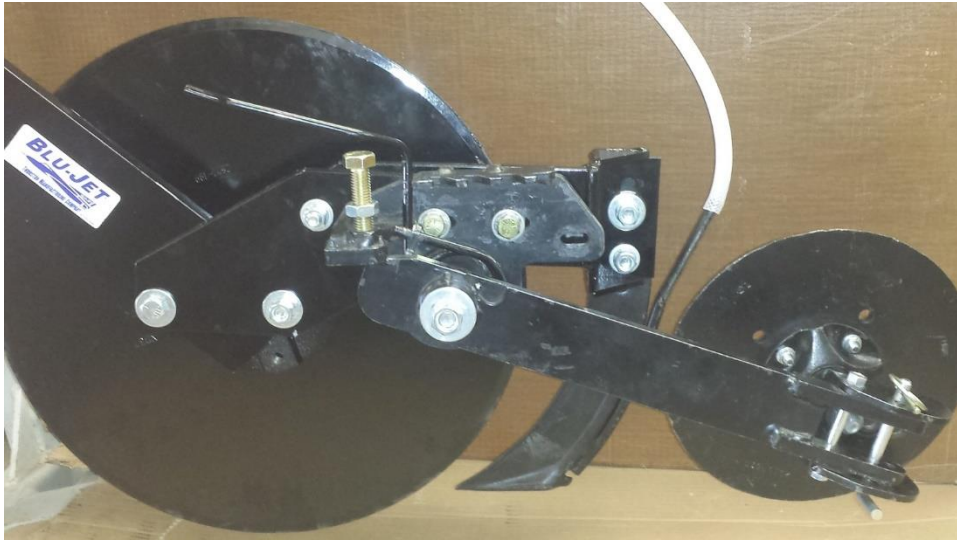

PHOTO ALBUM





A Tradition of Solutions since 1930

Yetter Farm Equipment Co

PO BOX 358 109 S. McDonough

Colchester, IL 62326-0358

Phone: 309-776-4111

Toll Free: 800-447-5777

Email: info@yetterco.com

For updated models and manuals visit the Yetter website:

www.yetterco.com

© Yetter Farm Equipment Co. All Rights Reserved