



6000-013 / 6000-014 / 6000-021

SERRATED CLOSING DISC

6000-017

SMOOTH CLOSING DISC

6000-022

SHARK TOOTH CLOSING DISC

INSTALLATION MANUAL

PART IDENTIFICATION

2565-777_REV_C • 12/2021



YETTER MANUFACTURING CO.
FOUNDED 1930

Colchester, IL 62326-0358

Toll free: 800/447-5777

309/776-3222 (Fax)

Website: www.yetterco.com

E-mail: info@yetterco.com

YETTER

PARTS IDENTIFICATION

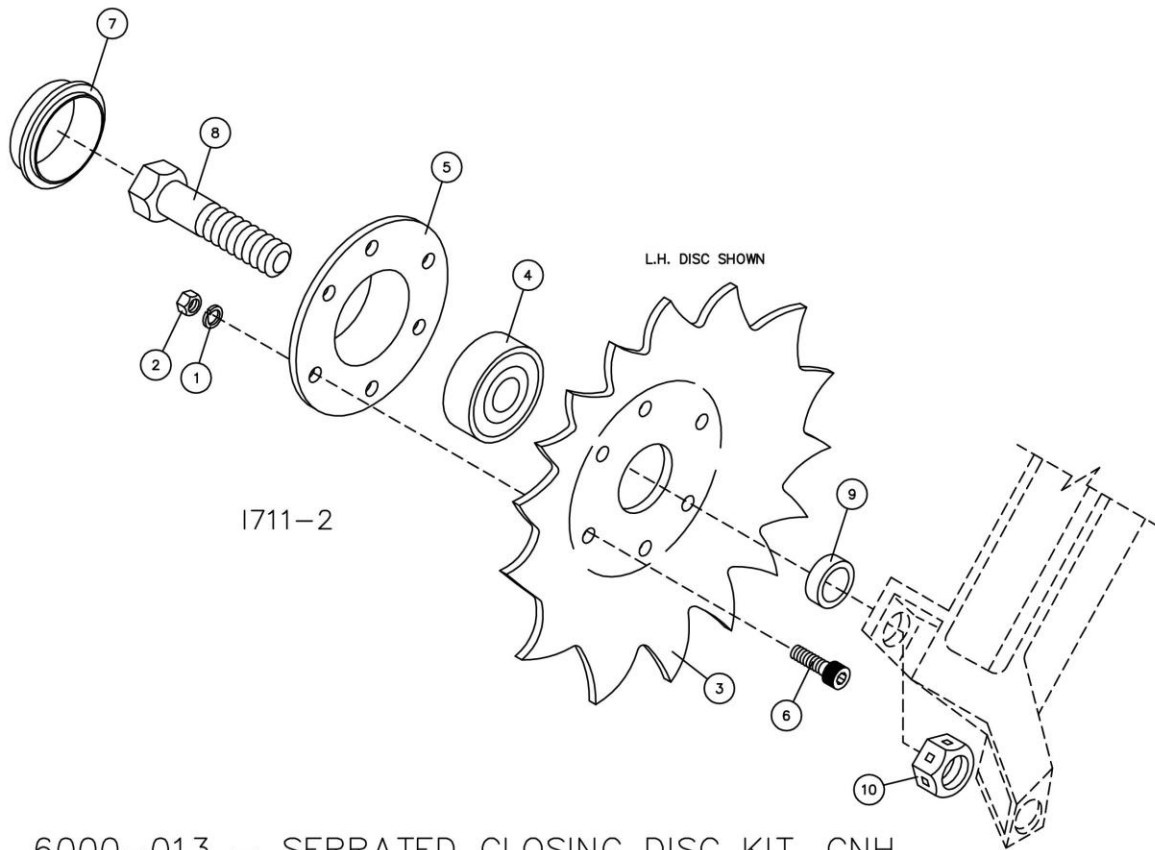

6000-013 – SERRATED CLOSING DISC KIT, CNH

DET	QTY	PART NO.	DESCRIPTION
1	6	2520-151	1/4-20 HEX NUT ZYD
2	6	2525-151	1/4 MED LOCK WASHER ZYD
3	1	6000-438	8" SERRATED CLOSING DISC, R.H.
	1	6000-437	8" SERRATED CLOSING DISC, L.H.
4	1	2550-328	PLANTER COULTER BRG. 204RY2
5	1	2570-711	HOUSING, BEARING J.D.#A51984
6	6	2513-510	1/4-20 X 3/4 SHCS BLACK
7	1	2570-542	DUST CAP, STEEL
8	1	2502-391	5/8-11 X 2 HHCS GR 5 ZYD.
9	1	2967-468	9/32" BUSHING
10	1	2520-459	5/8-11 HEX LOCK NUT ZYD.

MANUFACTURED 08/2004 – 05/2018

PARTS IDENTIFICATION

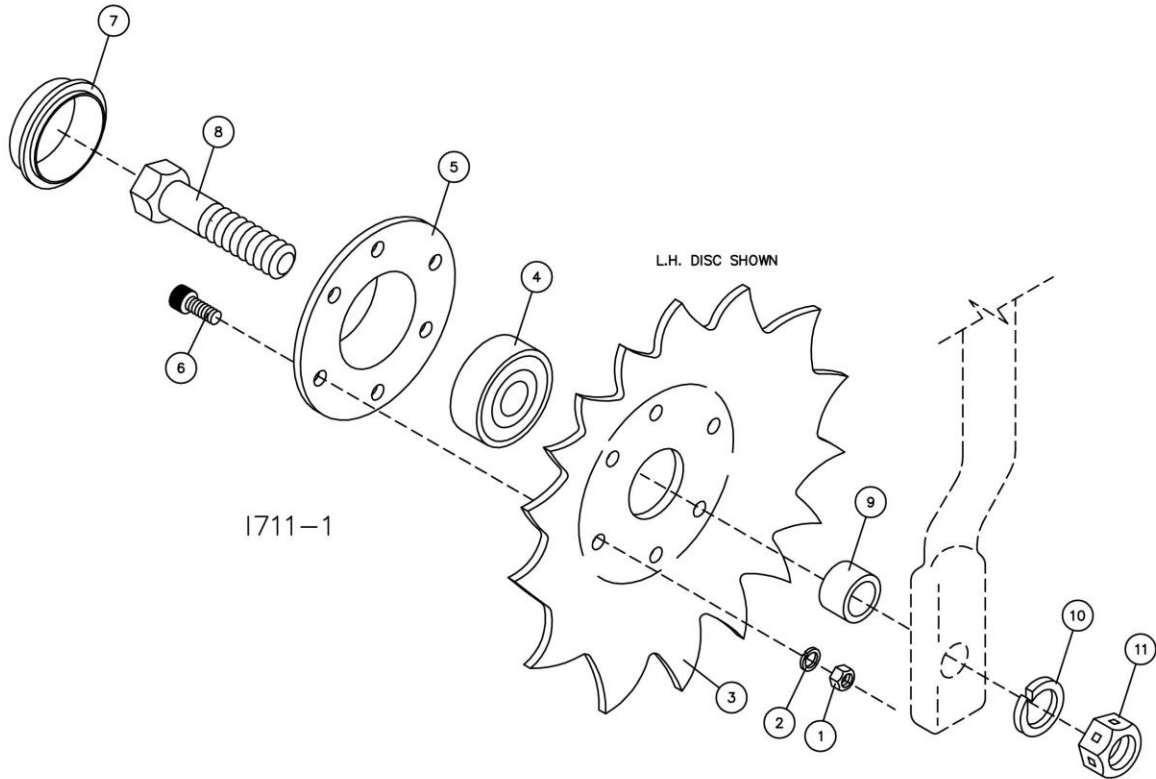

6000-014 – SERRATED CLOSING DISC KIT, JD

DET	QTY	PART NO.	DESCRIPTION
1	6	2520-151	1/4-20 HEX NUT ZYD
2	6	2525-151	1/4 MED LOCK WASHER ZYD
3	1	6000-438	8" SERRATED CLOSING DISC, R.H.
	1	6000-437	8" SERRATED CLOSING DISC, L.H.
4	1	2550-328	PLANTER COULTER BRG. 204RY2
5	1	2570-711	HOUSING, BEARING J.D.#A51984
6	6	2513-510	1/4-20 X 3/4 SHCS BLACK
7	1	2570-542	DUST CAP, STEEL
8	1	2502-393	5/8-11 X 2-1/2 HHCS GR 5 ZYD.
9	1	6000-335	9/16" BUSHING
10	1	2525-451	5/8 MED LOCK WASHER ZYD.
11	1	2520-459	5/8-11 HEX LOCK NUT ZYD.

MANUFACTURED 08/2004 – 05/2018

PARTS IDENTIFICATION
6000-013A
8" SERRATED CLOSING DISC KIT

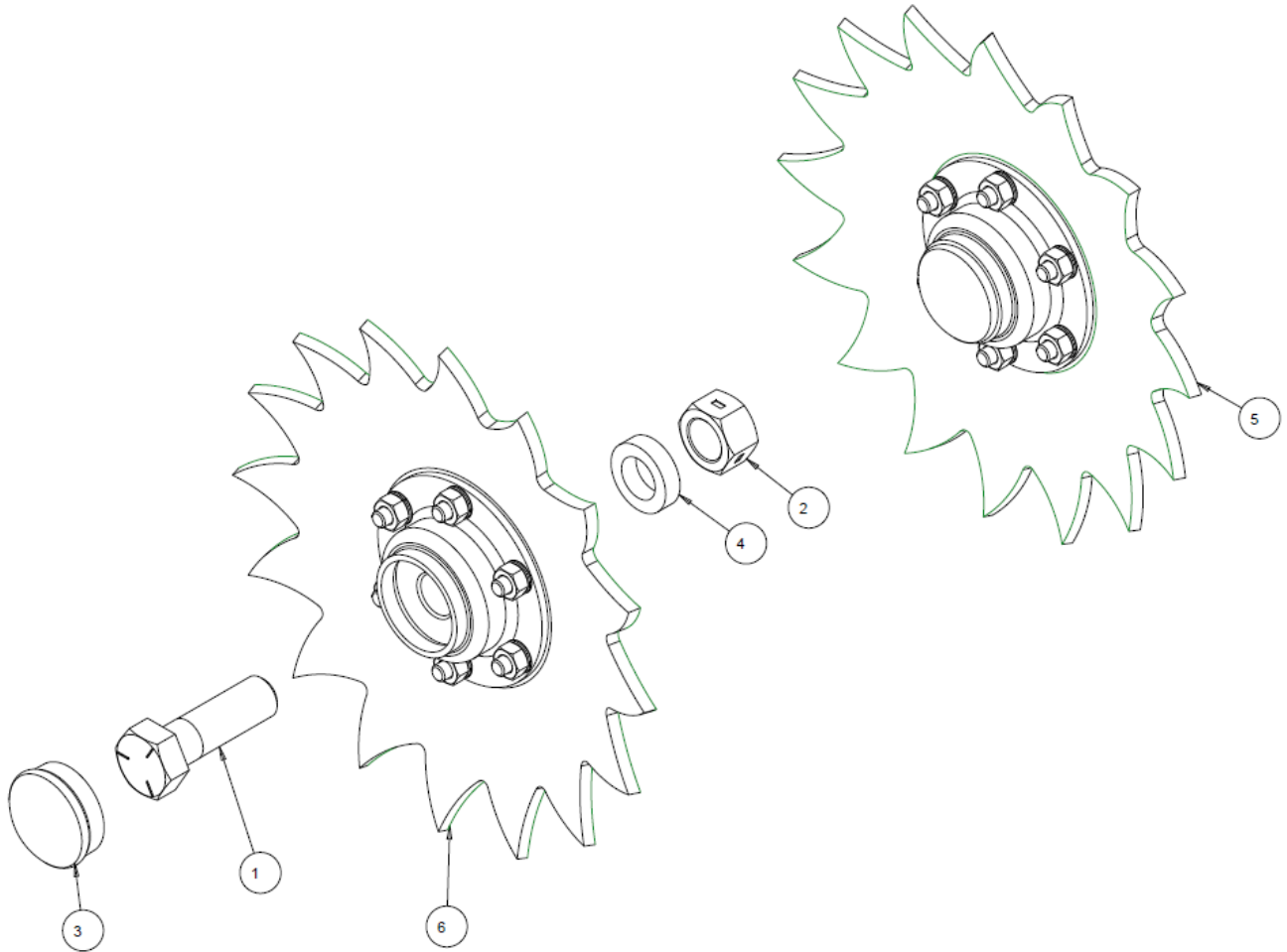

ITEM	PART NO.	DESCRIPTION	QTY
1	2502-391	5/8-11 X 2 HHCS GR 5 ZP	2
2	2520-459	5/8-11 LOCK HEX NUT, GR B, ZP	2
3	2570-789	HUB CAP	2
4	2967-468	9/32" PIVOT ARM BUSHING	2
5	6000-108 8"	SERRATED CLOSE DISC ASSY, LH, CNH 1	1
6	6000-109 8"	SERRATED CLOSE DISC ASSY. RH, CNH 1	1

MFG. 06/2018 TO CURRENT

PARTS IDENTIFICATION
6000-108_REV F
LEFT HAND 8" SERRATED CLOSING DISC (CNH)

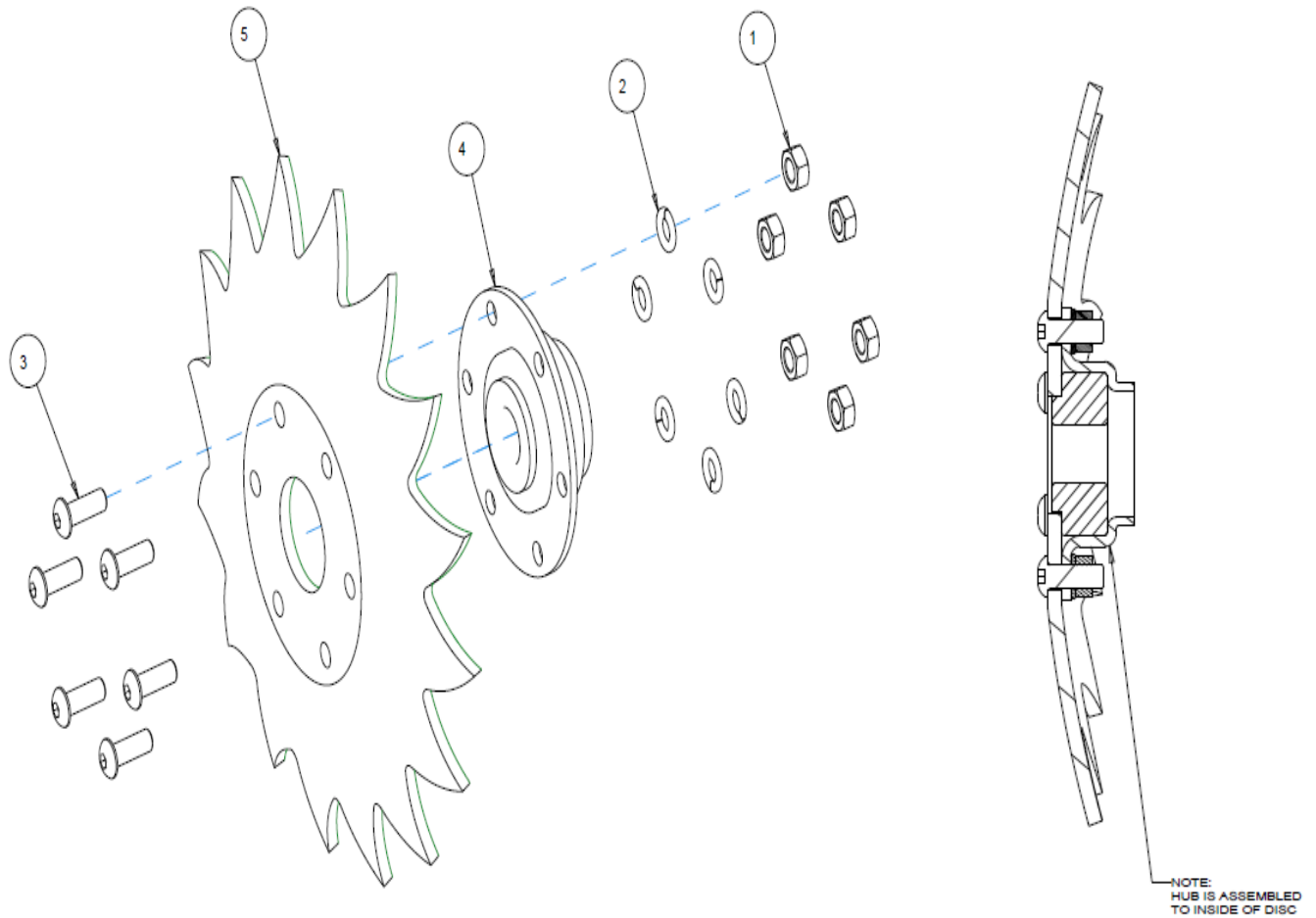

ITEM	PART NO.	DESCRIPTION	QTY
1	2520-151	1/4-20 HEX NUT ZP	6
2	2525-151	1/4 MED. LOCKWASHER ZP.	6
3	2570-202	1/4 -20 X 3/4 BHSCS ZP	6
4	6000-198	BEARING & HUB ASSEMBLY	1
5	6000-438	8" SERRATED CLOSING DISC, LH	1

MFG 06/2018 TO CURRENT

PARTS IDENTIFICATION
6000-109_REV G
RIGHT HAND 8" SERRATED CLOSING DISC (CNH)

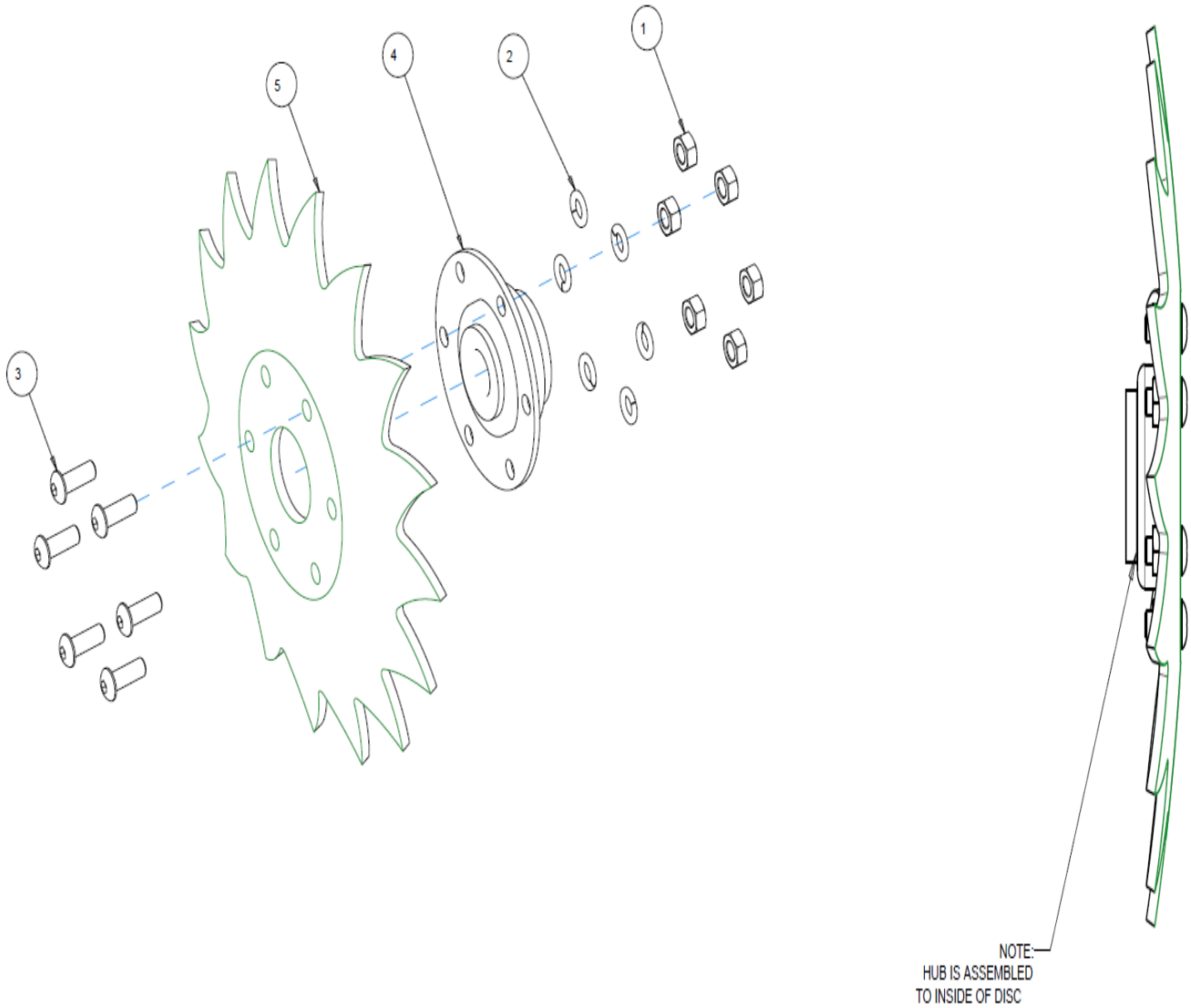

ITEM	PART NO.	DESCRIPTION	QTY
1	2520-151	1/4-20 HEX NUT ZP	6
2	2525-151	1/4 MED. LOCKWASHER ZP.	6
3	2570-202	1/4 -20 X 3/4 BHSCS ZP	6
4	6000-198	BEARING & HUB ASSEMBLY	1
5	6000-437	8" SERRATED CLOSING DISC, RH	1

MFG 06/2018 TO CURRENT

PARTS IDENTIFICATION
6000-014A
8" SERRATED CLOSING DISC KIT (JD)

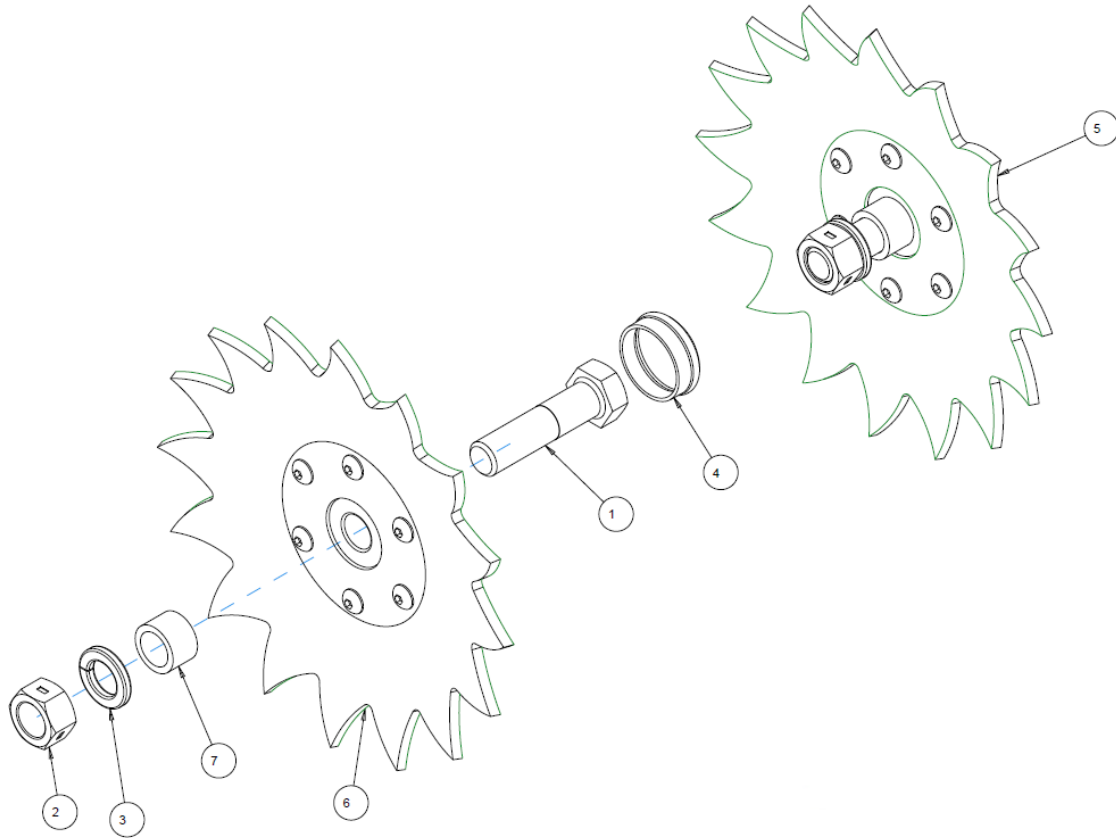

ITEM	PART NO.	DESCRIPTION	QTY
1	2502-393	5/8-11 X 2 1/2 HHCS GR5 ZP	2
2	2520-459	5/8-11 LOCK HEX NUT, GR B, ZP	2
3	2525-451	5/8 MED. LOCKWASHER ZP.	2
4	2570-789	HUB CAP	2
5	6000-114	8" SERR CLOSE DISC ASS'Y LH JD	1
6	6000-115	8" SERR CLOSE DISC ASS'Y RH JD	1
7	6000-335	9/16" BUSHING	2

MFG. 06/2018 TO CURRENT

PARTS IDENTIFICATION
6000-114
LEFT HAND 8" SERRATED CLOSING DISC (JD)

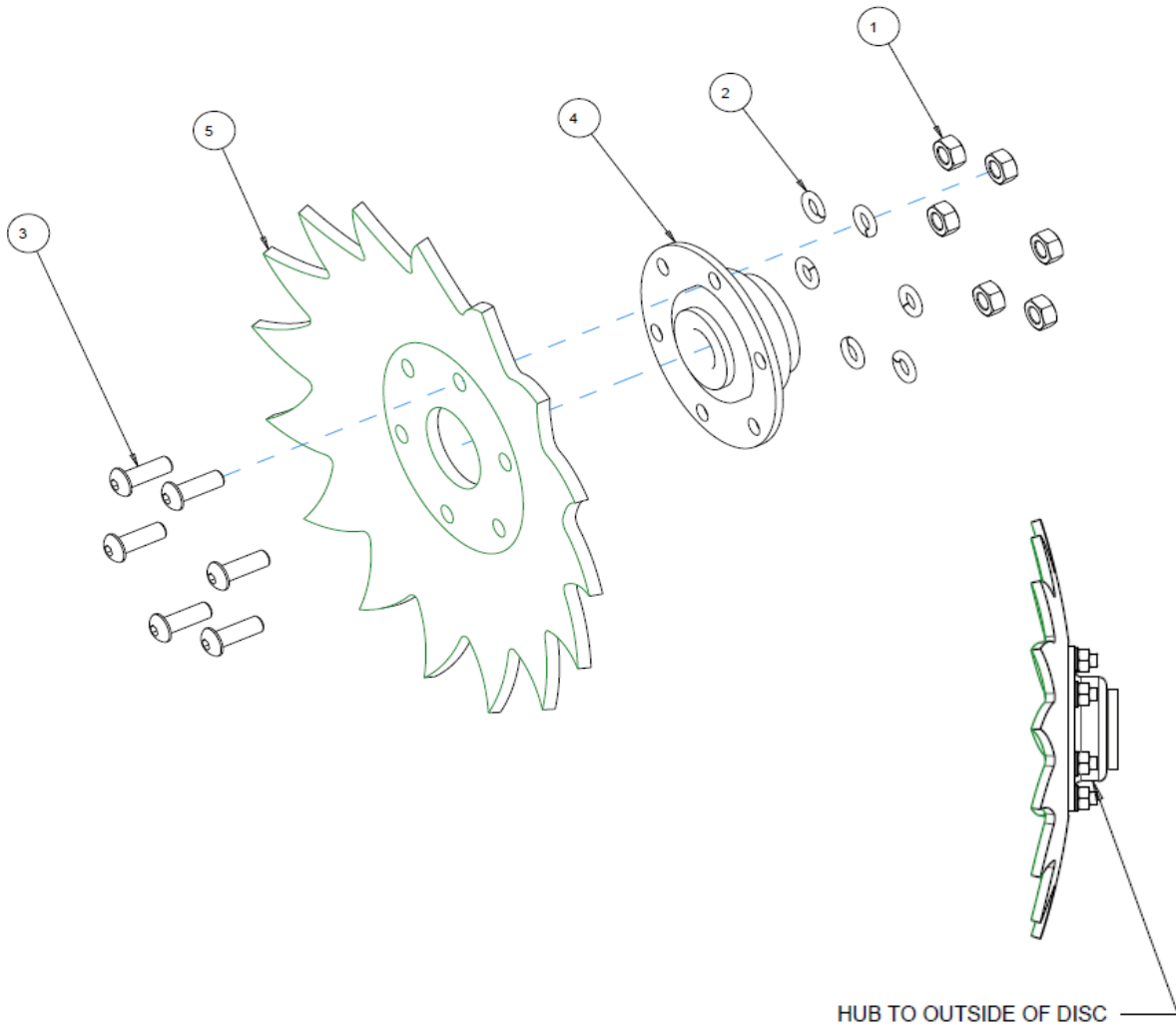

ITEM	PART NO.	DESCRIPTION	QTY
1	2520-151	1/4-20 HEX NUT ZP	6
2	2525-151	1/4 MED. LOCKWASHER ZP.	6
3	2570-202	1/4 -20 X 3/4 BHSCS ZP	6
4	6000-198	BEARING & HUB ASSEMBLY	1
5	6000-438	8" SERRATED CLOSING DISC, LH	1

MFG. 06/2018 TO CURRENT

PARTS IDENTIFICATION
6000-115
RIGHT HAND 8" SERRATED CLOSING DISC (JD)

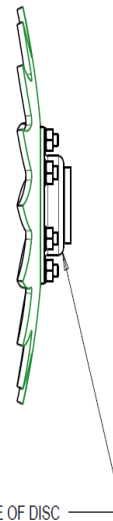
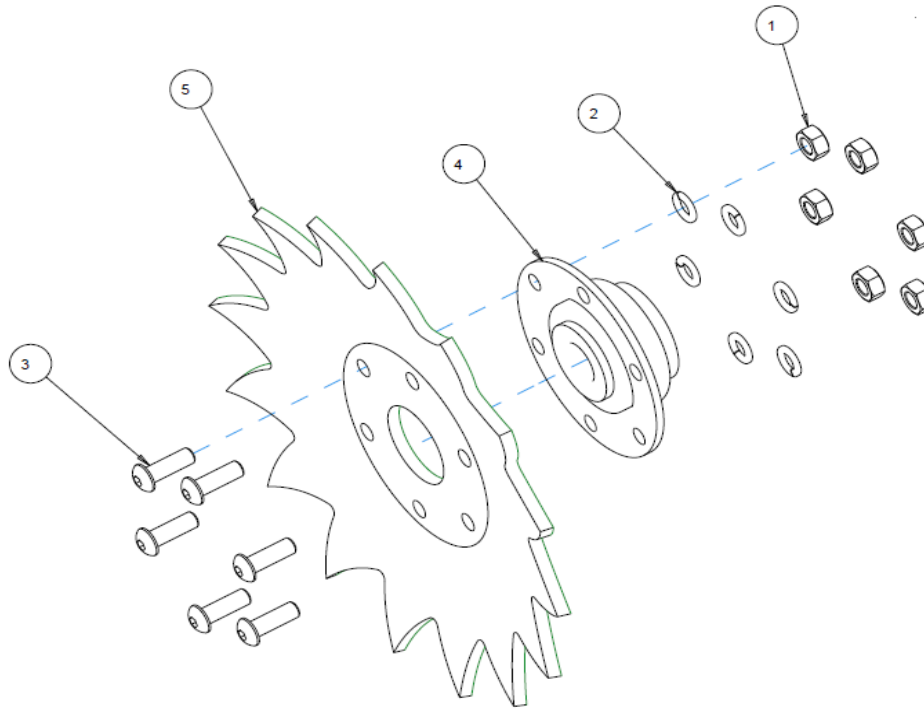

ITEM	PART NO.	DESCRIPTION	QTY
1	2520-151	1/4-20 HEX NUT ZP	6
2	2525-151	1/4 MED. LOCKWASHER ZP.	6
3	2570-202	1/4 -20 X 3/4 BHSCS ZP	6
4	6000-198	BEARING & HUB ASSEMBLY	1
5	6000-437	8" SERRATED CLOSING DISC, RH	1

PARTS IDENTIFICATION
6000-017
8" SMOOTH CLOSING DISC KIT CASEIH

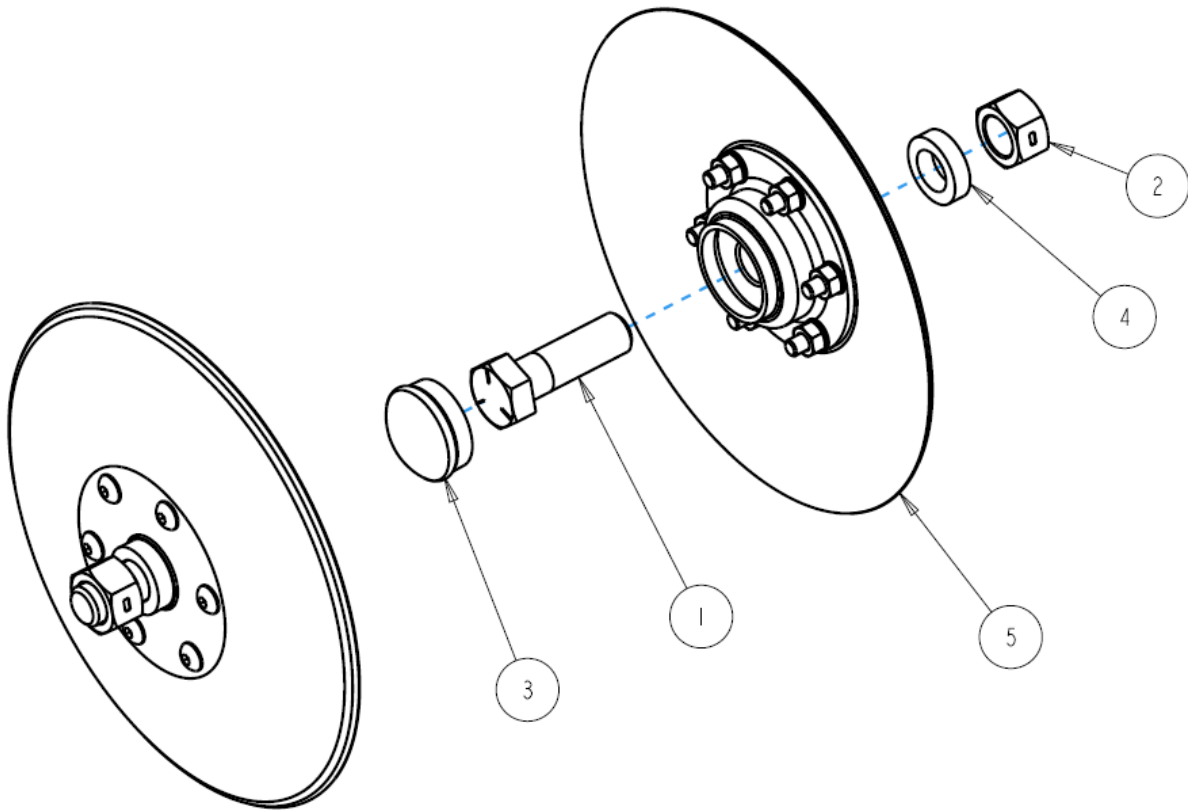

ITEM	PART NO.	DESCRIPTION	QTY
1	2502-391	5/8-11 X 2 HHCS GR 5 ZP	2
2	2520-459	5/8-11 LOCK HEX NUT, GR B, ZP	2
3	2570-789	HUB CAP	2
4	2967-468	9/32" PIVOT ARM BUSHING	2
5	6000-113	8" SMOOTH CLOSE DISC ASSY, CNH	2

PARTS IDENTIFICATION
6000-113
8" SMOOTH CLOSING DISC ASSEMBLY CASEIH

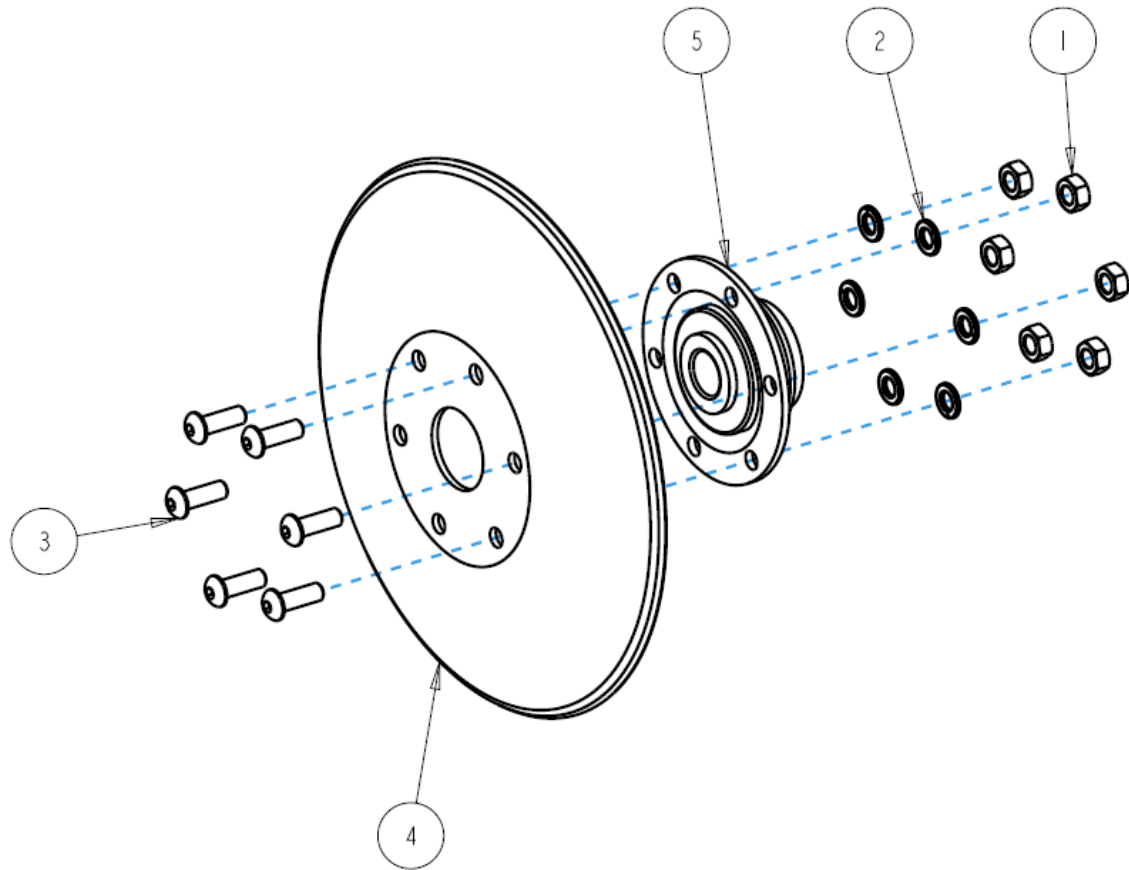

ITEM	PART NO.	DESCRIPTION	QTY
1	2520-151	1/4-20 HEX NUT ZP	6
2	2525-151	1/4 MED. LOCKWASHER ZP.	6
3	2570-202	1/4 -20 X 3/4 BHSCS ZP	6
4	2571-437	8" SMOOTH CLOSING DISC	1
5	6000-198	BEARING & HUB ASSEMBLY	1

PARTS IDENTIFICATION
6000-021
9" SERRATED CLOSING DISC KIT

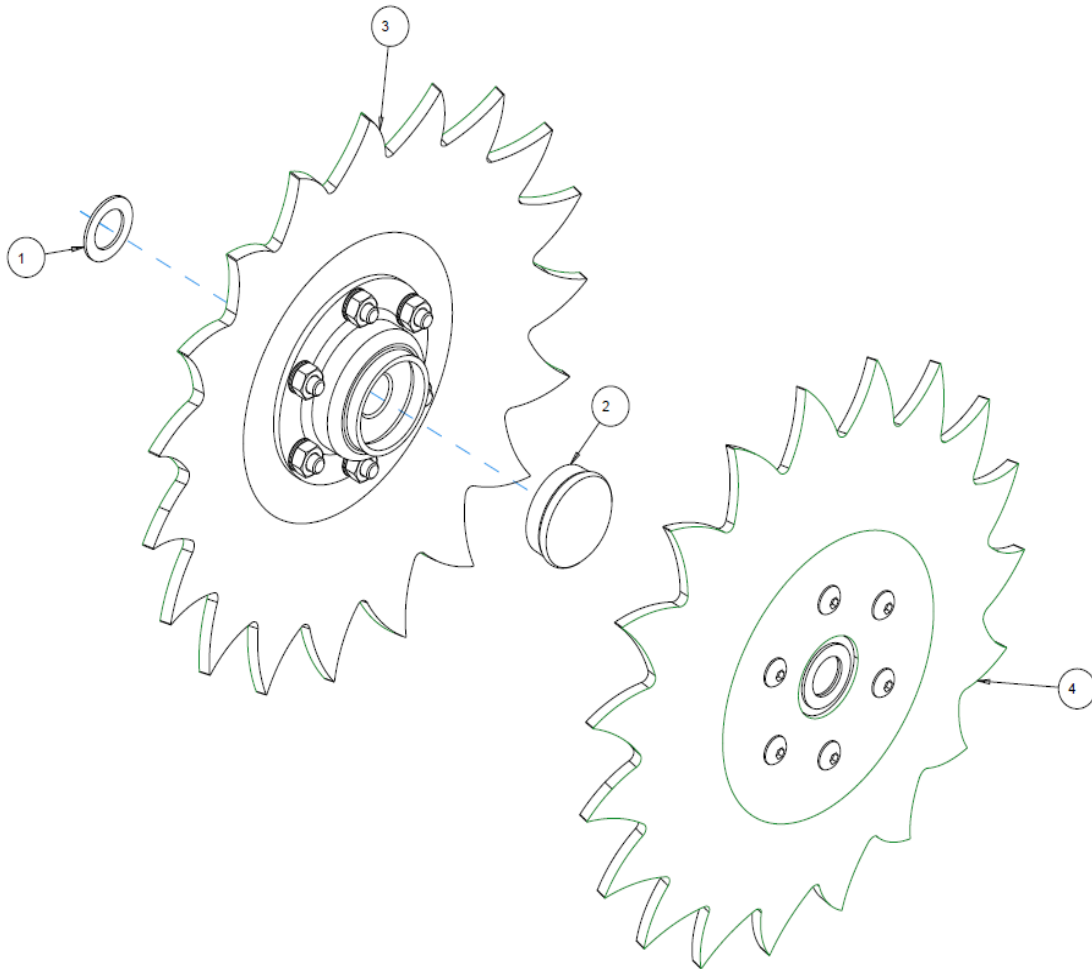

ITEM	PART NO.	DESCRIPTION	QTY
1	2527-562	5/8IDX1ODX.049+-0.002M BU ZP	2
2	2570-789	HUB CAP	2
3	6000-110	9" CLOSING DISC ASSEMBLY, RH	1
4	6000-111	9" CLOSING DISC ASSEMBLY, LH	1



PARTS IDENTIFICATION
6000-110
RIGHT HAND 9" SERRATED CLOSING DISC KIT

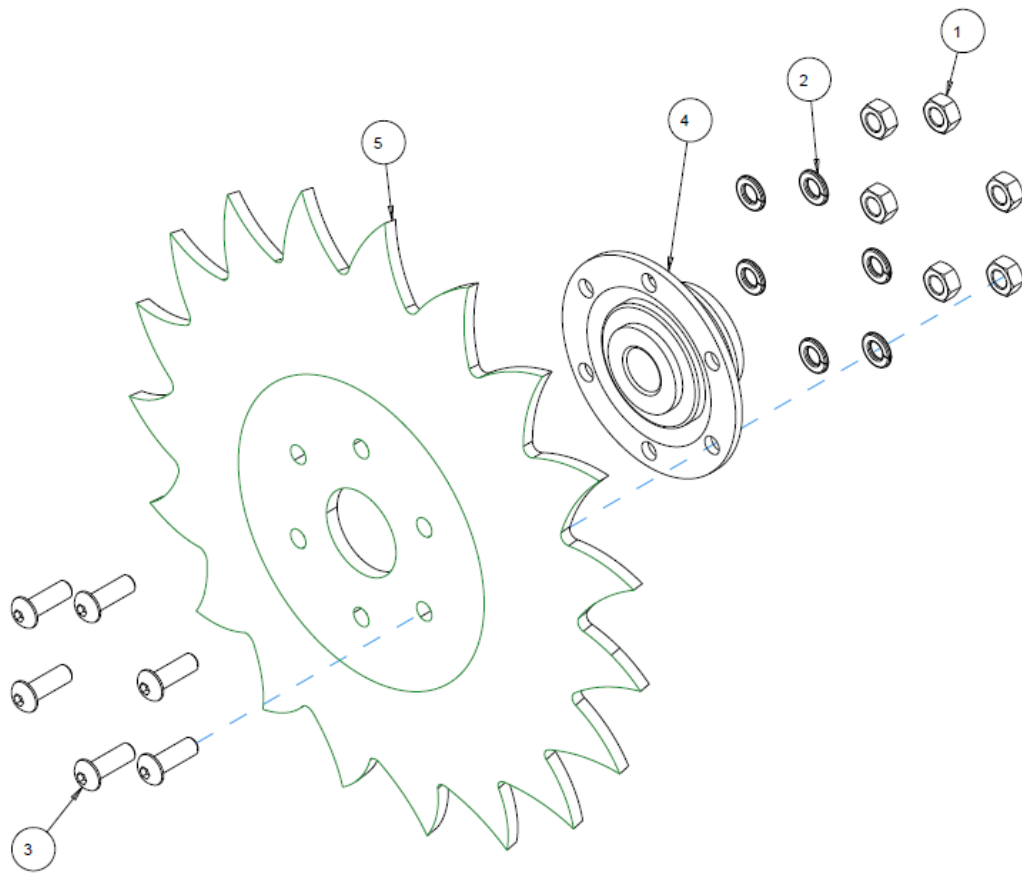

ITEM	PART NO.	DESCRIPTION	QTY
1	2520-151	1/4-20 HEX NUT ZP	6
2	2525-151	1/4 MED. LOCKWASHER ZP.	6
3	2570-202	1/4 -20 X 3/4 BHSCS ZP	6
4	6000-198	BEARING & HUB ASSEMBLY	1
5	6000-439	9" SERRATED CLOSING DISC, RH	1

PARTS IDENTIFICATION
6000-111
LEFT HAND 9" SERRATED CLOSING DISC KIT

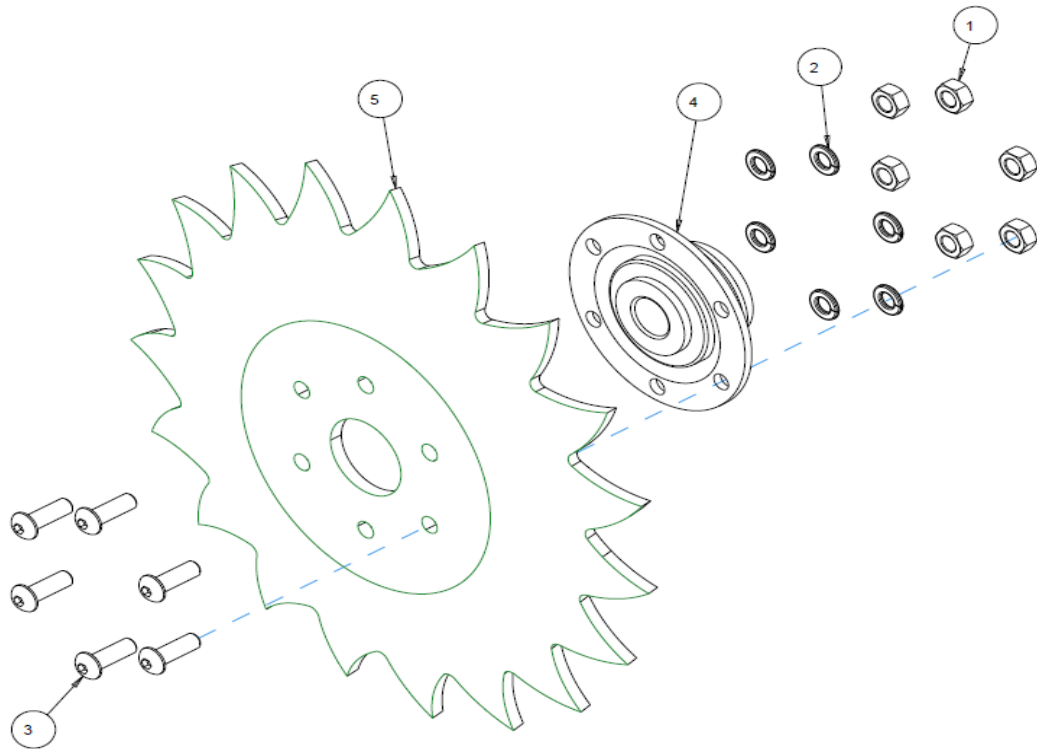

ITEM	PART NO.	DESCRIPTION	QTY
1	2520-151	1/4-20 HEX NUT ZP	6
2	2525-151	1/4 MED. LOCKWASHER ZP.	6
3	2570-202	1/4 -20 X 3/4 BHSCS ZP	6
4	6000-198	BEARING & HUB ASSEMBLY	1
5	6000-440	9" SERRATED CLOSING DISC, LH	1

ASSEMBLY
6000-022
9" SHARKTOOTH CLOSING DISC KIT

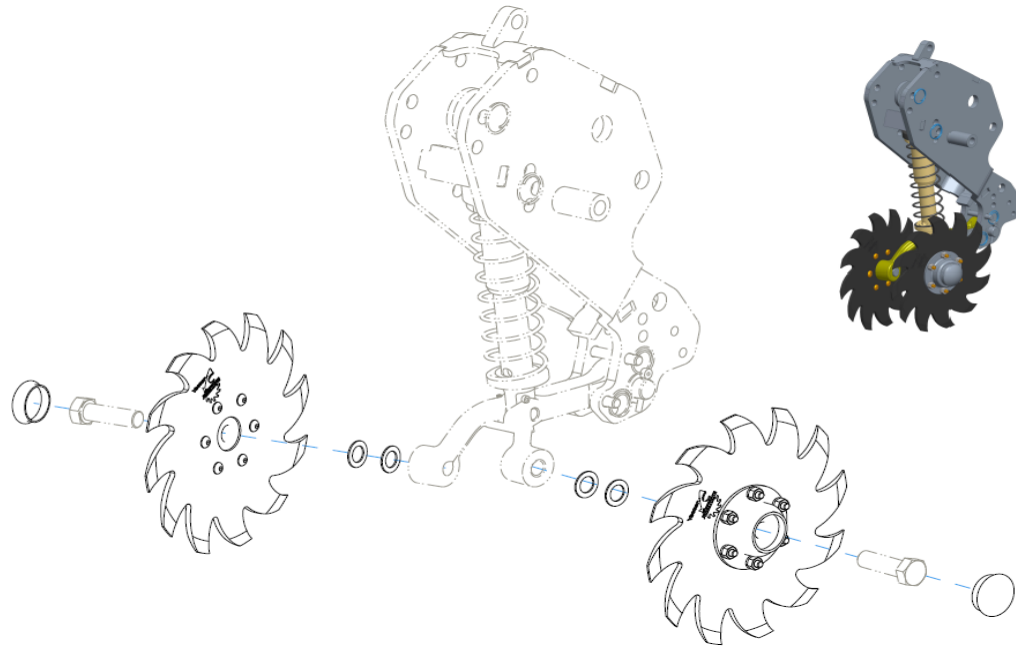

PARTS IDENTIFICATION
6000-022
9" SHARKTOOTH CLOSING DISC KIT

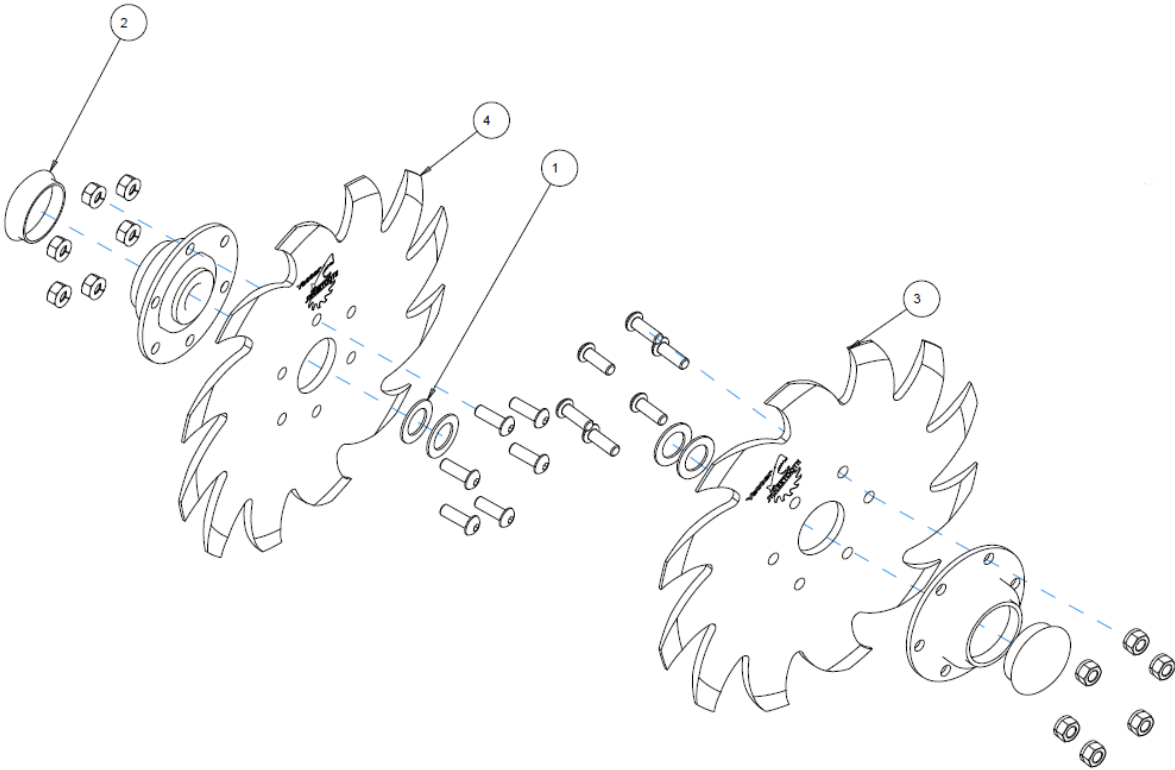

ITEM	PART NO.	DESCRIPTION	QTY
1	2527-562	5/8IDX1ODX.049+-002M BU ZP	4
2	2570-789	HUB CAP	2
3	6000-116	9" CLOSING DISC ASSEMBLY, RH	1
4	6000-117	9" CLOSING DISC ASSEMBLY, LH	1



PARTS IDENTIFICATION
6000-116
RIGHT HAND DISC ASSEMBLY

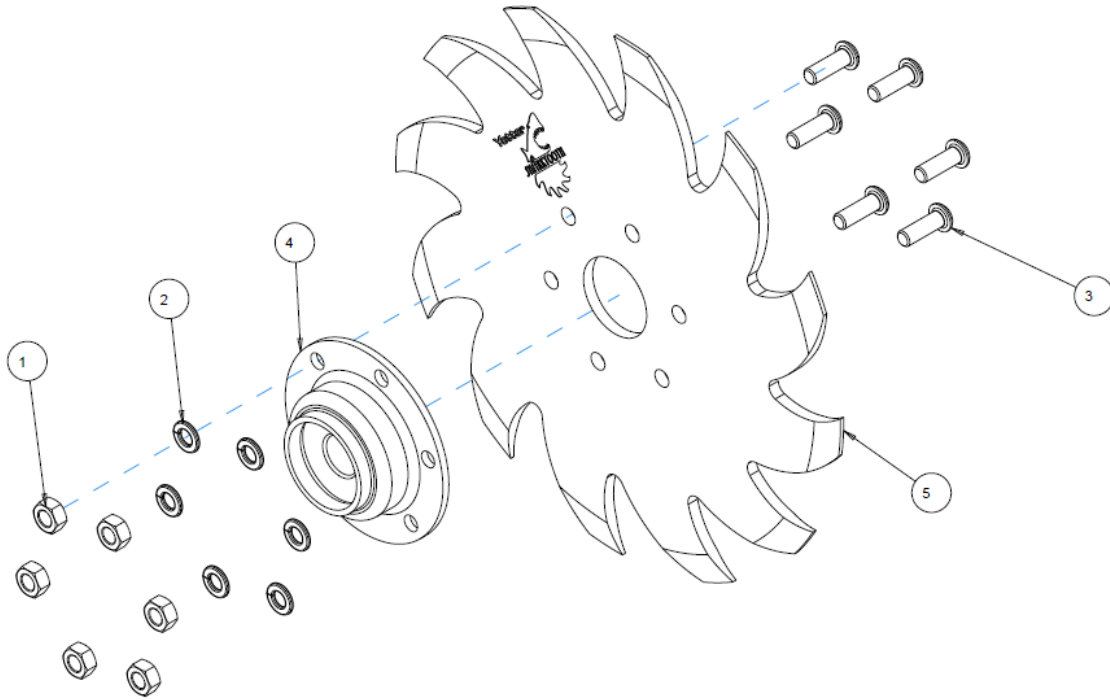

ITEM	PART NO.	DESCRIPTION	QTY
1	2520-151	1/4-20 HEX NUT ZP	6
2	2525-151	1/4 MED. LOCKWASHER ZP.	6
3	2570-202	1/4 -20 X 3/4 BHSCS ZP	6
4	6000-198	BEARING & HUB ASSEMBLY	1
5	6000-441	9" SHARK TOOTH WHEEL, WITH CHAMFER	1

PARTS IDENTIFICATION
6000-117
LEFT HAND DISC ASSEMBLY

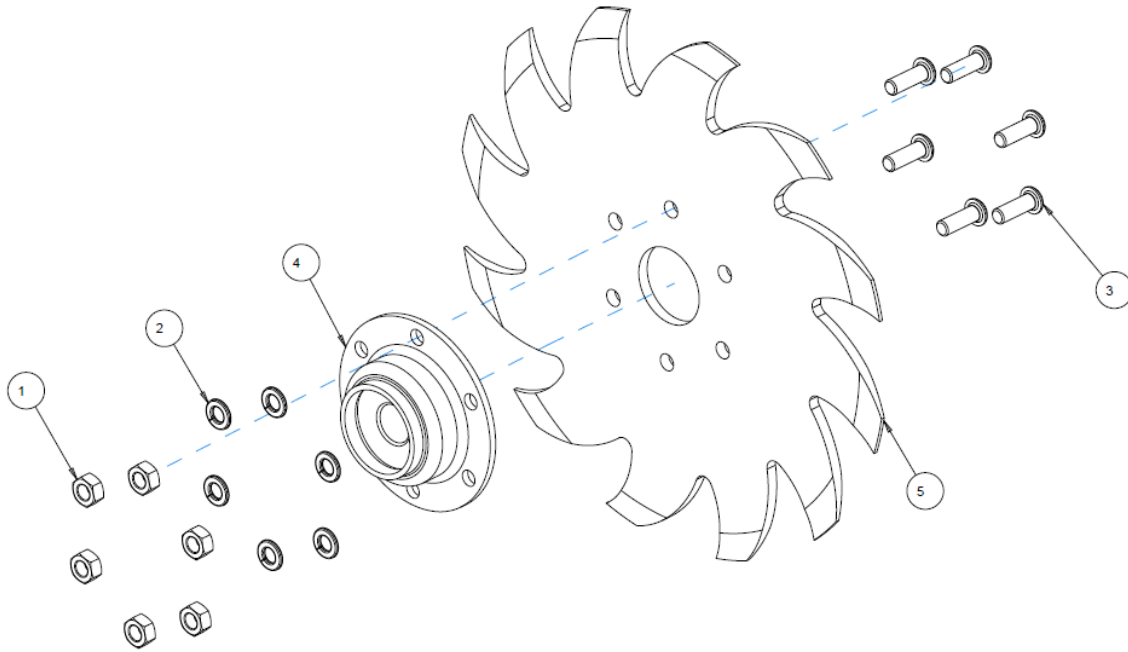

ITEM	PART NO.	DESCRIPTION	QTY
1	2520-151	1/4-20 HEX NUT ZP	6
2	2525-151	1/4 MED. LOCKWASHER ZP.	6
3	2570-202	1/4 -20 X 3/4 BHSCS ZP	6
4	6000-198	BEARING & HUB ASSEMBLY	1
5	6000-441	9" SHARK TOOTH WHEEL, WITH CHAMFER	1

PARTS IDENTIFICATION
6000-198
BEARING/HUB ASSEMBLY

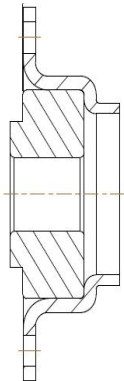
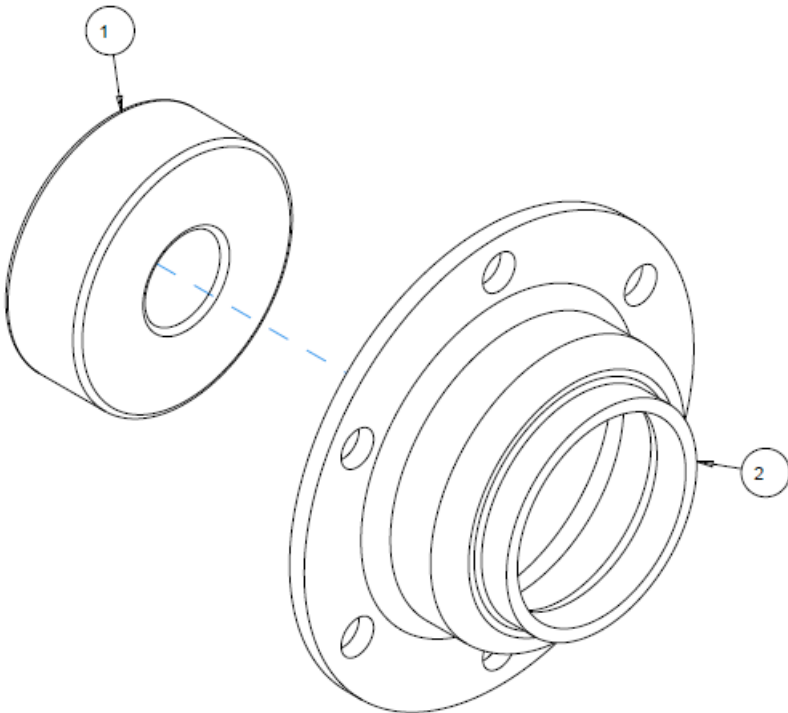

ITEM	PART NO.	DESCRIPTION	QTY
1	2550-071	BEARING	1
2	2570-788	HOUSING	1

Our name Is getting known

Just a few years ago, Yetter products were sold primarily to the Midwest only. Then we embarked on a program of expansion and moved into the East, the South, the West and now north into Canada. We're even getting orders from as far away as Australia and Africa.

So, when you buy Yetter products . . .you're buying a name that's recognized. A name that's known and respected. A name that's become a part of American agriculture and has become synonymous with quality and satisfaction in the field of conservation tillage.

Thank you.

YETTER MANUFACTURING CO.

Colchester, IL 62326-0358 • 309/776-4111

Toll Free 800/447-5777

Fax 309/776-3222

Website: WWW.YETTERCO.COM

E-MAIL: INFO@YETTERCO.COM

2565-777_REV_C • 12/2021