



2995 XFC Fertilizer Coulter 2995 XCC Cutting Coulter

OPERATORS MANUAL WITH PARTS IDENTIFICATION

2565-788_REV_E • 03/2023



YETTER MANUFACTURING CO.
FOUNDED 1930

Colchester, IL 62326-0358
Toll free: 800/447-5777
309/776-3222 (Fax)

Website: www.yetterco.com
E-mail: info@yetterco.com

YETTER

FOREWORD

You've just joined an exclusive but rapidly growing club.

For our part, we want to welcome you to the group and thank you for buying a Yetter product.

We hope your new Yetter products will help you achieve both goals-increase your productivity and increase your efficiency so that you may generate more profit.

This operator's manual has been designed into four major sections: Foreword, Safety Precautions, Installation Instructions and Parts Breakdown.

This **SAFETY ALERT SYMBOL** indicates important safety messages in the manual.



When you see this symbol, be alert to the possibility of **PERSONAL INJURY** and carefully read the message that follows.

The word **NOTE** is used to convey information that is out of context with the manual text. It contains special information such as specifications, techniques and reference information of a supplementary nature.

The word **IMPORTANT** is used in the text when immediate damage will occur to the machine due to improper technique or operation. Important will

apply to the same information as specified by note only of an immediate and urgent nature.

It is the responsibility of the user to read the operator's manual and comply with the safe and correct operating procedure and to lubricate and maintain the product according to the maintenance schedule in the operator's manual.

The user is responsible for inspecting his machine and for having parts repaired or replaced when continued use of the product would cause damage or excessive wear to the other parts.

It is the user's responsibility to deliver his machine to the Yetter dealer who sold him the product for service or replacement of defective parts, which are covered by the warranty policy.

If you are unable to understand or follow the instructions provided in this publication, consult your local Yetter dealer or contact:

YETTER MANUFACTURING CO.

309/776-4111

800/447-5777

309/776-3222 (FAX)

Website: www.yetterco.com

E-mail: info@yetterco.com

WARRANTY

Yetter Manufacturing warrants all products manufactured and sold by it against defects in material. This warranty being expressly limited to replacement at the factory of such parts or products as shall appear to be defective after inspection. This warranty does not obligate the Company to bear cost of labor in replacement of parts. It is the policy of the Company to make improvements without incurring obligations to add them to any unit already sold. No warranty is made or authorized to be made, other than herein set forth. This warranty is in effect for one year after purchase.

Dealer _____

Yetter Manufacturing warrants its own products only and cannot be responsible for damages to equipment on which mounted.

SAFETY



A brief description of signal words that may be used in this manual:

CAUTION: Used as a general reminder of good safety practices or to direct attention to unsafe practices.

WARNING: Denotes a specific potential hazard.

DANGER: Denotes the most serious specific potential hazard.

SAFETY PRECAUTIONS

You can make your farm a safer place to live and work if you observe the safety precautions given. Study these precautions carefully and insist that they be followed by those working with you and for you.

Finally, remember this: an accident is usually caused by someone's carelessness, neglect, or oversight.



WARNING

Never clean, lubricate or adjust a machine that is in motion. Always lower or block the implement before performing service.

If machine must be serviced in the raised position, jack or block it up to prevent it from accidentally falling and injuring someone.

Do not allow riders on the tractor or implement.

Use speeds and caution dictated by the terrain being traversed. Do not operate on any slope steep enough to cause tipping or loss of control.

Be sure all personnel are clear of the immediate area before operating.

Read and understand the operator's manual and require all other persons who will operate the equipment to do the same.

Be familiar with all tractor and implement controls and be prepared to stop engine and implements quickly in an emergency.



CAUTION

Consult your implement and tractor operator's manual for correct and safe operating practices.

Beware of towed implement width and allow safe clearance.

FAILURE TO HEED MAY RESULT IN PERSONAL INJURY OR DEATH.

GENERAL INFORMATION

2995 Xtreme™ (XFC) Fertilizer Coulters



STANDARD FEATURES FOR ALL MODELS

- 20" blade available in smooth, ripple or notched
- Down pressure set at 2000 lbs
- Coulters allow 6" of vertical travel
- Available with injection or rear knife
- Mounting kits available for: 4" sq., 4" x 6" 6" x 4", 6" sq., 5" x 7" and 7" sq
- Available in right and left hand models

Order parts from A, B, C, and D to complete coulters assembly

Section A: XFC Fertilizer Coulters

Order manual: 2565-788

Model No.	Description	Est Wt.
2995-086-L	LH XFC Xtreme™ Fertilizer Coulters assy	58 lbs
2995-086	RH XFC Xtreme™ Fertilizer Coulters assy	58 lbs

Section B: Shank

2995-243	20" Coulters Shank	14 lbs
2995-255	25" Coulters Shank	18 lbs

Section C: Blades

2571-168	.157 x 20" Multi-hole fluted	13 lbs
2571-199	.157 x 20" Multi-hole flat blade	14 lbs

Section D: Injector/Knife Kit (Not applicable with 2995-087)

2995-083	Injector Kit	2 lbs
2995-084	Fertilizer Knife Kit - with 3/8" tube	5 lbs

Section E: Mount Kit (toolbar width x height)

2995-080	Rigid Mount Bracket 4x4 & 4x6	(requires 1 u-bolt kit)	9 lbs
2995-081	Offset Mount Bracket 4x4, 4x6, 5x5, 5x7, 7x5, 7x4 & 7x7	(requires 2 u-bolt kits)	16 lbs
2995-088	Rigid Mount Bracket 6x4, 6x6, 7x4, 7x5, 7x7	(requires 1 u-bolt kit)	11 lbs
2995-092	Rigid C-shank Mount Bracket 4x4, 5x5, 6x6, 7x7	(requires 2 u-bolt kits)	22 lbs
2995-098	Vertical Toolbar Mount Bracket 2.5x2.5, 3x3, 5x5, 6x6	(call Yetter)	8 lbs
2995-099	Rigid Mount Bracket 5x5, 5x7	(requires 1 u-bolt kit)	9 lbs

Section F: U-bolt Kits

6000-030	4" x 4" toolbar 3/4" u-bolt kit	2 lbs
6000-031	4" x 6" toolbar 3/4" u-bolt kit	2 lbs
6000-032	5" x 5" toolbar 3/4" u-bolt kit	2 lbs
6000-033	5" x 7" toolbar 3/4" u-bolt kit	2 lbs
6000-034	6" x 4" toolbar 3/4" u-bolt kit	2 lbs
6000-035	6" x 6" toolbar 3/4" u-bolt kit	2 lbs
6000-036	7" x 5" toolbar 3/4" u-bolt kit	2 lbs
6000-037	7" x 7" toolbar 3/4" u-bolt kit	2 lbs

2995 Xtreme™ (XCC) Cutting Coulters

STANDARD FEATURES FOR ALL MODELS

- Has 1 3/4" diameter mount shank
- Down pressure set at 2000 lbs
- Allows 6" of vertical travel
- Mounting kits available for: 4" sq., 4" x 6" 6" x 4", 6" sq., 5" x 7" and 7" sq
- Available Right Hand only

Order from Section A Below
And then B, D, E and F above

Section A: XCC Coulters

Order manual: 2565-788

Model No.	Description	Est Wt.
2995-087	XCC Xtreme™ Cutting Coulters 14 5/8" to 20" Blade	51 lbs

Section C: Blades

2571-168	.157 x 20" Multi-hole fluted	13 lbs
2571-199	.157 x 20" Multi-hole flat blade smooth	14 lbs

Section A: XCC Coulters

Model No.	Description	Est Wt.
2995-089	XCC Xtreme™ Cutting Coulters 24" Blade	51 lbs

Section C: Blades

2571-282	.25 x 24.8" Flat blade smooth	32 lbs
----------	-------------------------------	--------

GENERAL INFORMATION

2995 XTREME COULTER

2995-400 HUB/ BLADE BOLT PATTERN

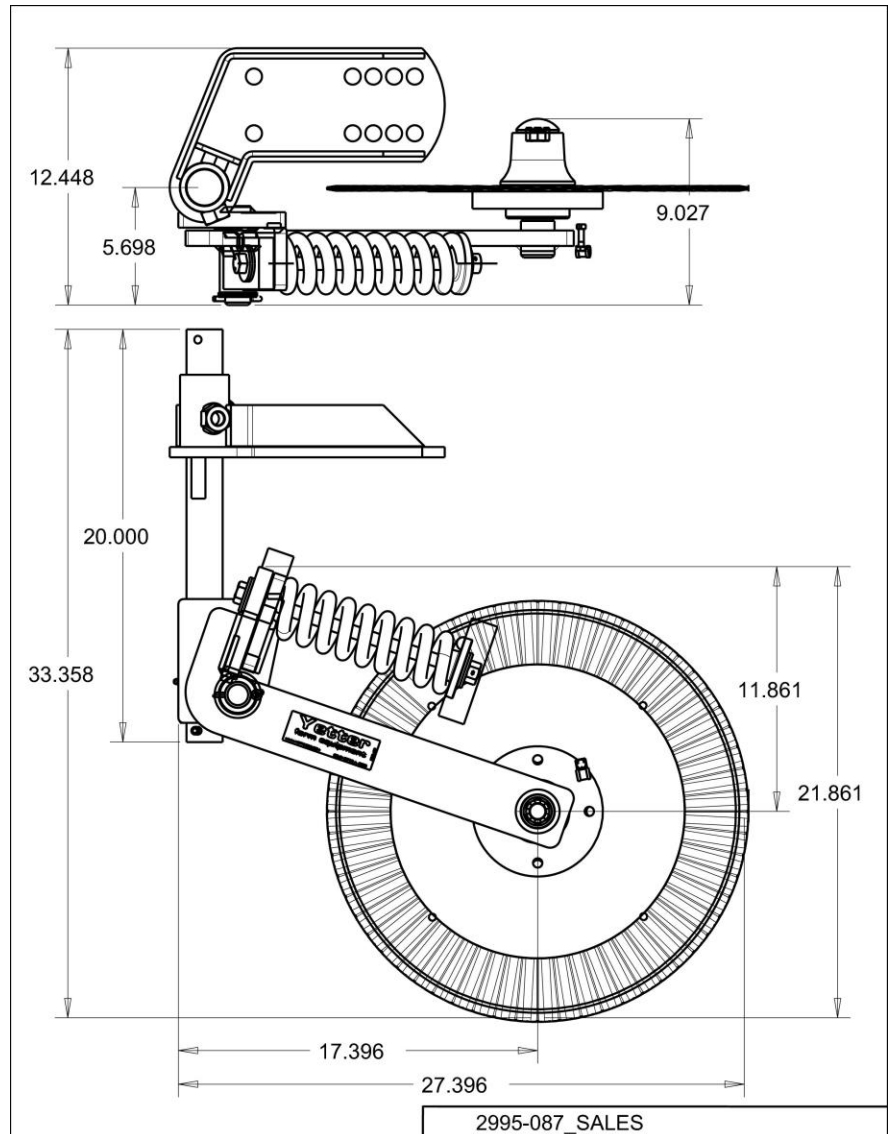
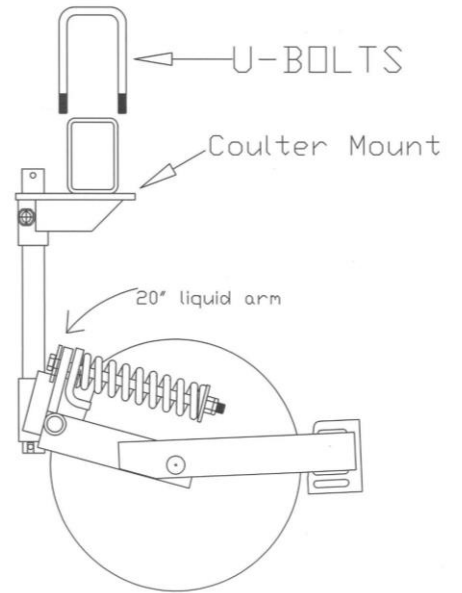
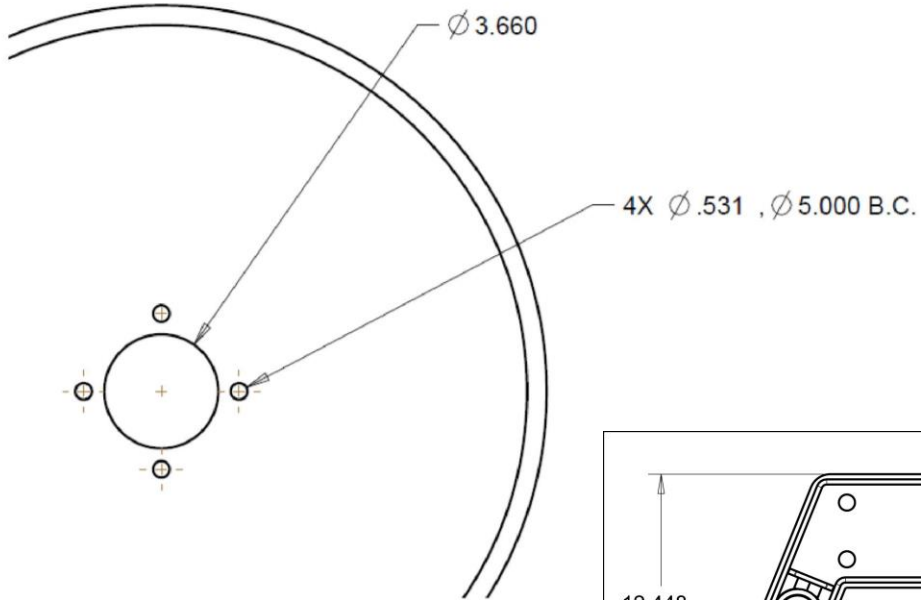

TOOLBAR GUIDE

MANUFACTURER	SIZE (INCHES)		MODEL
	HORIZONTAL	VERTICAL	
AG SYSTEMS	6	4	6000
AG SYSTEMS	6	4	7200 & 8000
BLU-JET	7	7	AT 3000
BLU-JET	6	6	AT 5000
BLU-JET	6	4	LAND RUNNER
BLU-JET	6	6	AT 6010
CLARK	4	6	
CNH/DMI	4	4	small bar
CNH/DMI	4	6	2800
CNH/DMI	4	6	3000 SERIES
CNH/DMI	4	6	4000 SERIES
CNH/DMI	4	6	5000 SERIES
DALTON	4	6	DUAL RANK
DALTON	4	6	DW3000, DW6000
FAST	7	7	8100 MAIN FRAME
FAST	5	7	8100 WING FRAME
FAST	4	6	8129 TWIN FRAME
KBH	4	7	
KONGSKILDE/PROGRESSIVE	7	7	2500 & 2450
KONGSKILDE/PROGRESSIVE	7	5	1300
P & H	4	6	2880
P & H	6	4	2897
SCHABEN	4	6	LA9000

TOOLBAR GUIDE

Single Toolbar mounting for RIGID C-SHANK Mount Coulter Clamp

Toolbar size: Horizontal dimension X Vertical dimension

Example: 4" X 6" = 4" horizontal X 6" vertical

Toolbar size	U-Bolt	Mount Kit
Horiz. X Vertical	2 per row	
4X4	6000-030	2995-082
4X6	6000-031	2995-082
5X5	6000-032	2995-082
5X7	6000-033	2995-082
6X4		n/a
6X6		n/a
7X5	6000-036	2995-082
7X7	6000-037	2995-082

Double Toolbar mounting for RIGID MOUNT Coulter Clamp on front toolbar

Toolbar size: Horizontal dimension X Vertical dimension

Example: 4" X 6" = 4" horizontal X 6" vertical

Toolbar size	U-Bolt	Mount Kit
Horiz. X Vertical	1 per row	
4X4	6000-030	2995-080/2995-088
4X6	6000-031	2995-080/2995-088
5X5		n/a
5X7		n/a
6X4	6000-034	2995-088
6X6	6000-035	2995-088
7X5	6000-036	2995-088
7X7	6000-037	2995-088

Double Toolbar mounting for RIGID MOUNT 4" Offset Right Hand Coulter Clamp on front toolbar

Toolbar size: Horizontal dimension X Vertical dimension

Example: 4" X 6" = 4" horizontal X 6" vertical

Toolbar size	U-Bolt	Mount Kit
Horiz. X Vertical	2 per row	
4X4	6000-030	2995-081
4X6	6000-031	2995-081
5X5	6000-032	2995-081
5X7	6000-033	2995-081
6X4		n/a
6X6		n/a
7X5	6000-036	2995-081
7X7	6000-037	2995-081

MAINTENANCE

- After a few hours use, check all bolts and setscrews for tightness.
- After using a few hours, check for loose hardware, re-tighten as needed.
- After a few days use, check coultter hubs for loose bearings. There should be no end play in the hub bearings to allow it to wobble. If necessary, remove hub cap and cotter pin, adjust slotted nut to remove wobble, re-insert cotter pin and replace hub cap.

LUBRICATION



DANGER: Always install safety lock-ups or lower the planter to the ground before working on the machine. Lubricate at frequency indicated with a multi-purpose type grease.

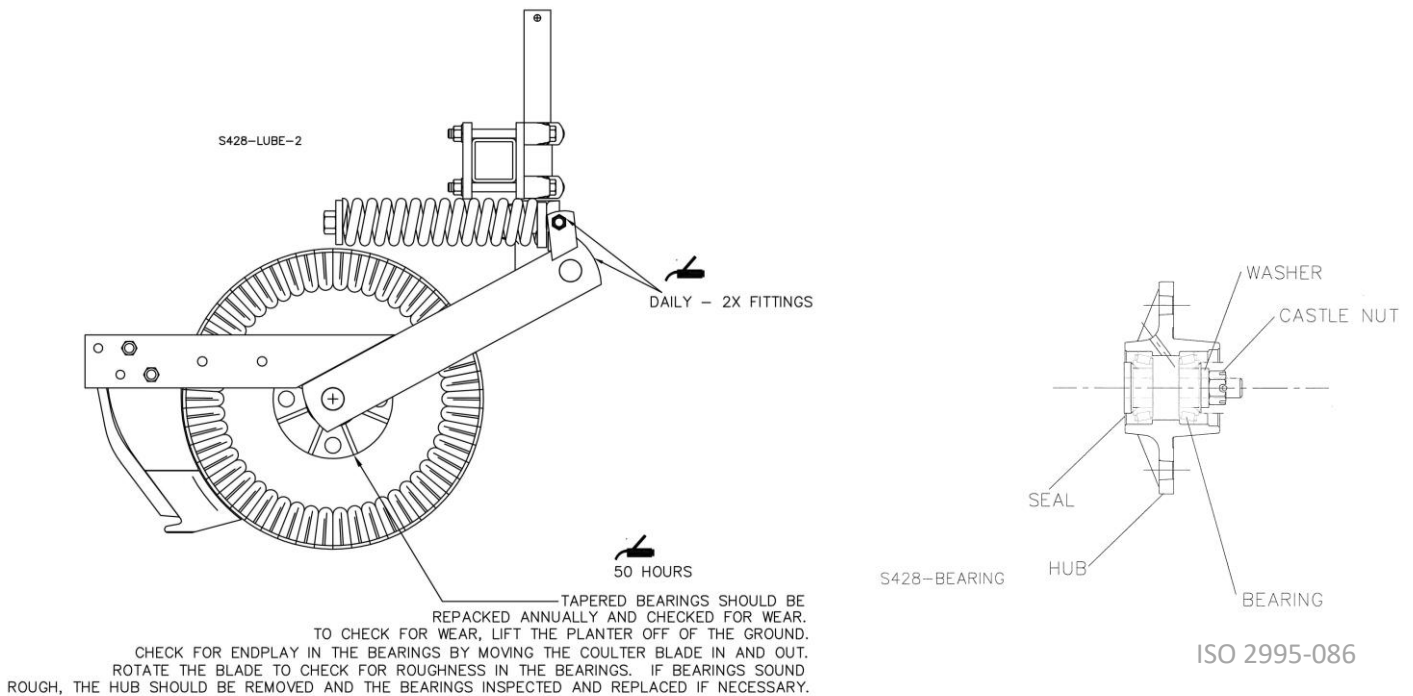

DANGER: Always install all safety lock-ups and safety lock pins before working under the toolbar.

1. Raise the toolbar until it is clear off the ground. Remove the gauge wheel and the blade. Remove the hubcap, cotter pin, slotted nut and washer from the spindle shaft assembly.
2. Pull the coultter spindle shaft assembly from the hub. Remove bearing cones and cups and discard if bearings are being replaced. Clean hub and dry. Remove bearings only and not cups of re-packing.
3. Wash the old grease from the hub, bearing cups, coultter spindle shaft, seal, and bearing cones. Inspect the condition of bearing cups and cones.
4. Apply #2 multi-purpose lithium grease on each bearing. Make sure the space around each roller is filled. Lubricate the bearing cups.
5. Position the bearing in the cup and install the seal. Lubricate the seal lips and proceed with re-assembly of the removed parts including the blade. Blade bolt torque is 90 to 96 ft. lbs.
6. Install outer bearing, washer, and slotted nut. Tighten the slotted nut to 150 in. lbs. while rotating the blade or until a definite drag is felt when the blade is turned by hand. Tighten the nut one slot position to line up the cotter pin hole with a slot. Secure the nut with a new cotter pin.

ASSEMBLY INSTRUCTIONS

STEP 1. Install shank to the coultter assembly.

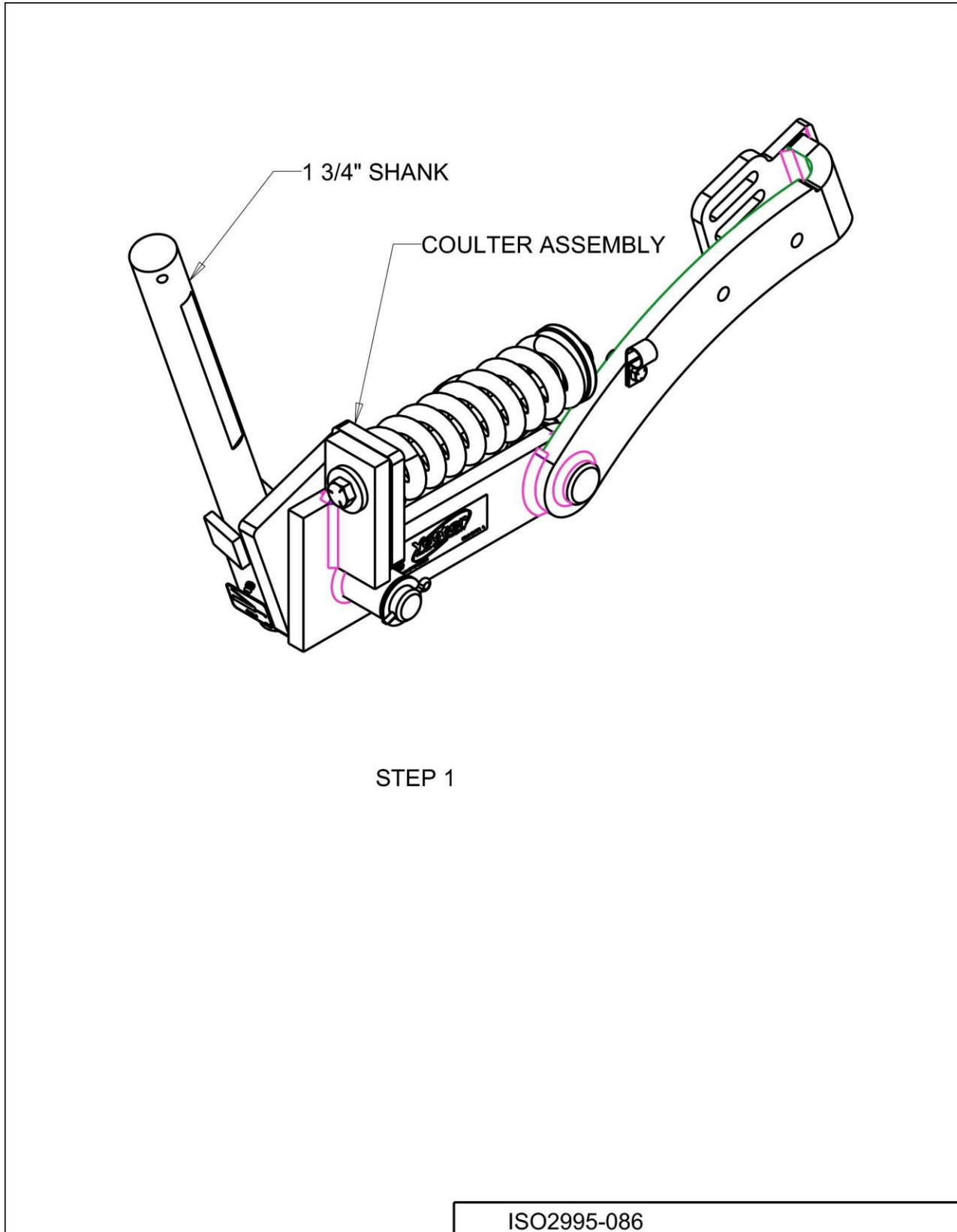

ASSEMBLY INSTRUCTIONS

STEP 2. Install roll pin to the shank.

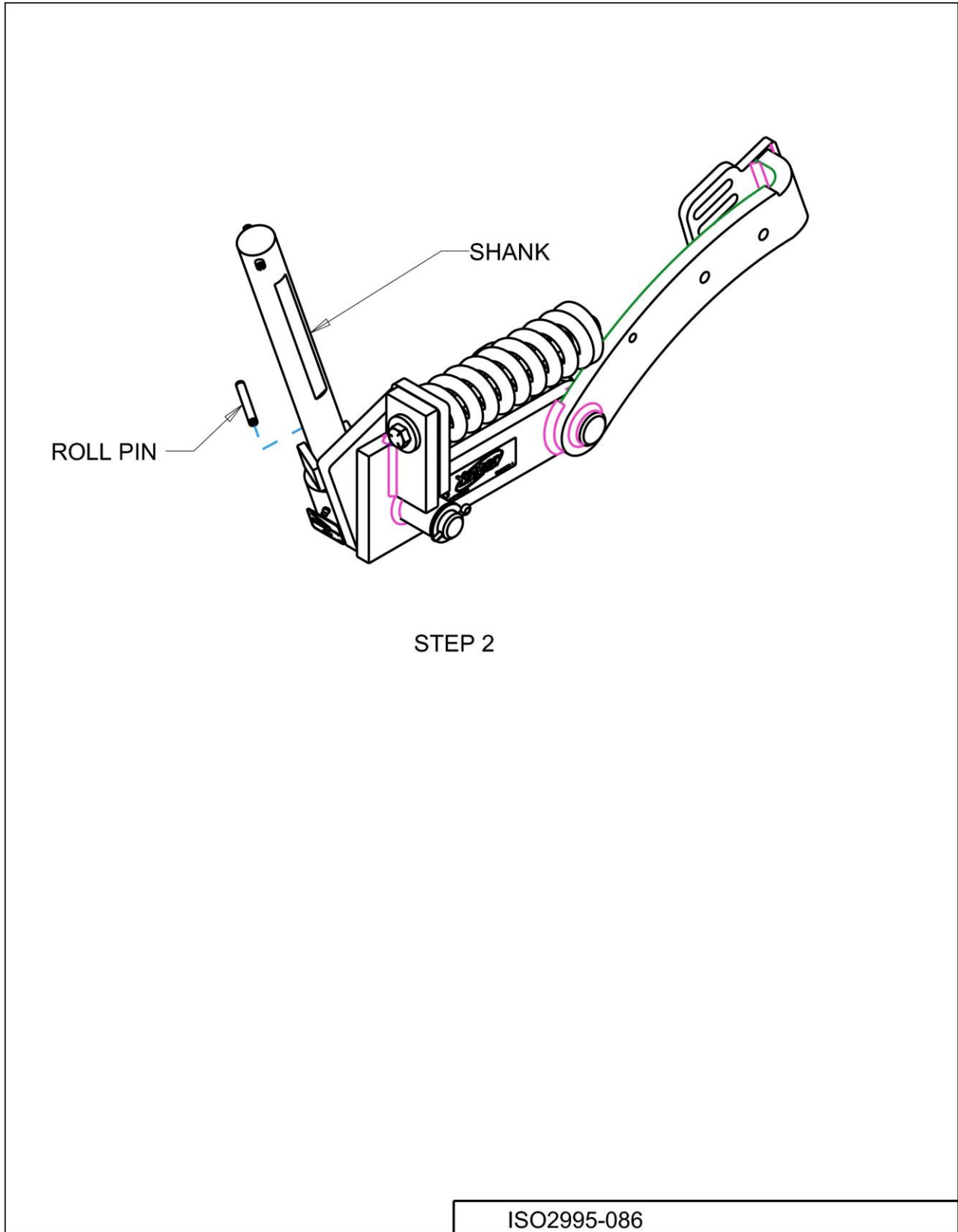

ASSEMBLY INSTRUCTIONS

STEP 3. Attach the blade to the coultter assembly using the 4) 1/2" – 20 X 1" Hex Head Bolts.

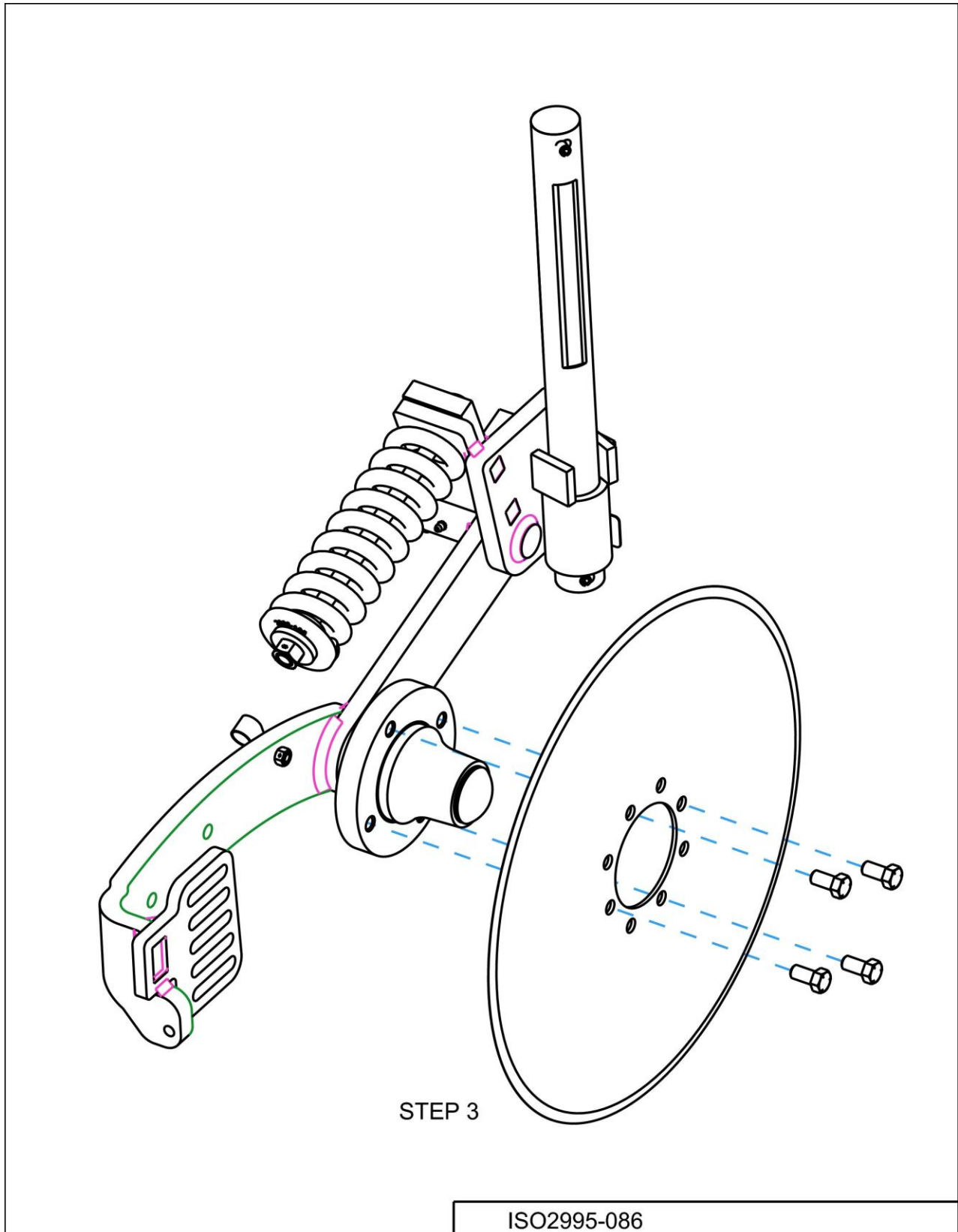

ASSEMBLY INSTRUCTIONS

STEP 4. Attach the toolbar clamp to the frame.

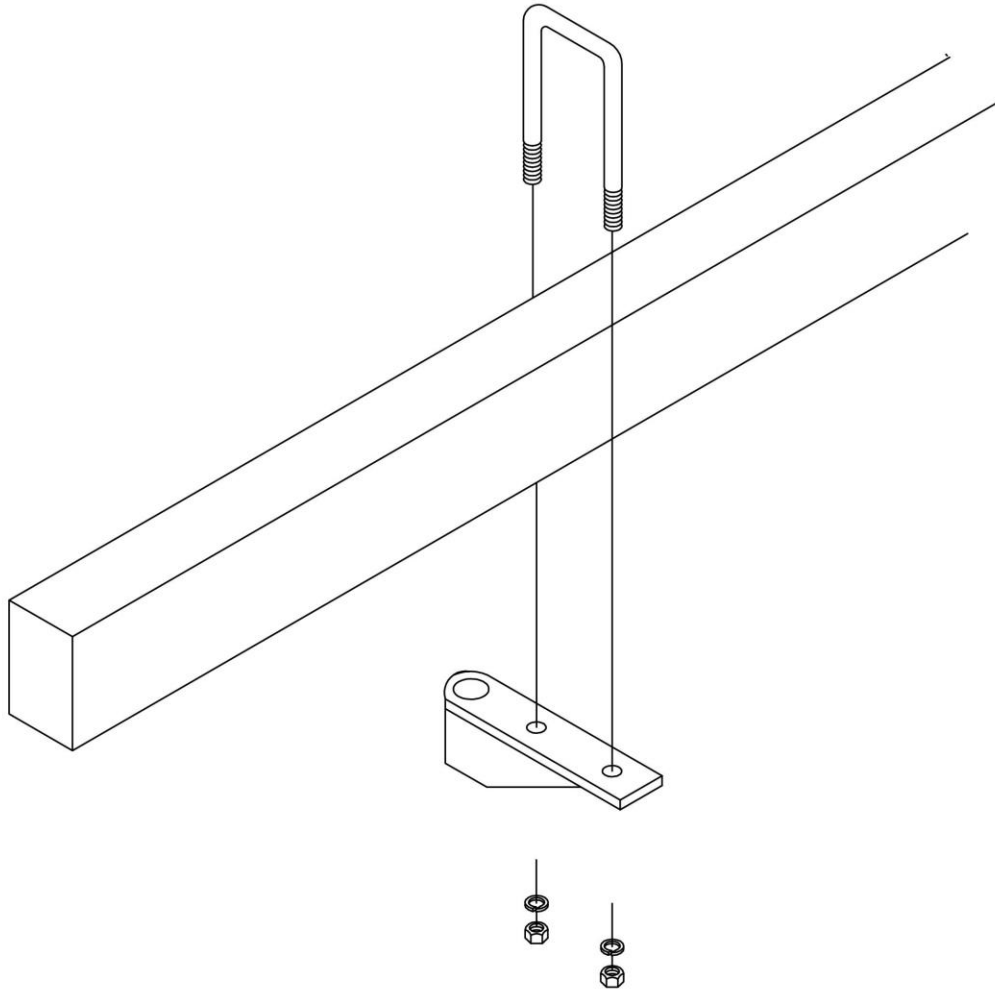

ISO 2995-086_1

ASSEMBLY INSTRUCTIONS

STEP 5. Loosely assemble the set screws and lock nuts to the toolbar clamp.

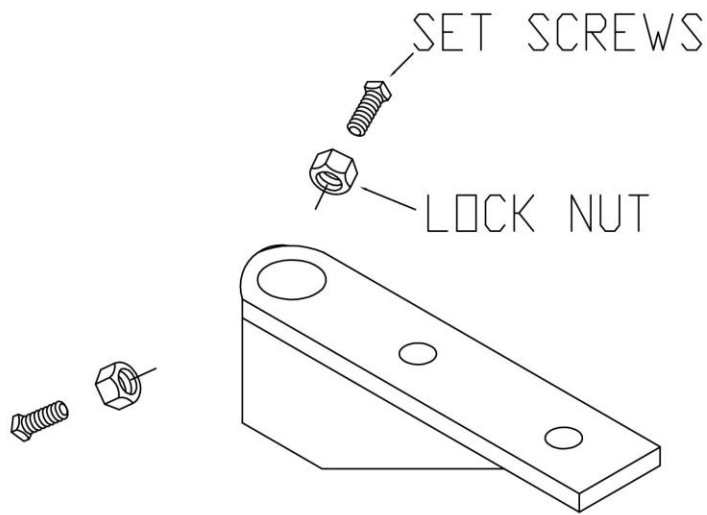

ISO 2995-086_1

ASSEMBLY INSTRUCTIONS

STEP 6. Slide shank into the toolbar clamp. Install roll pin to the shank.

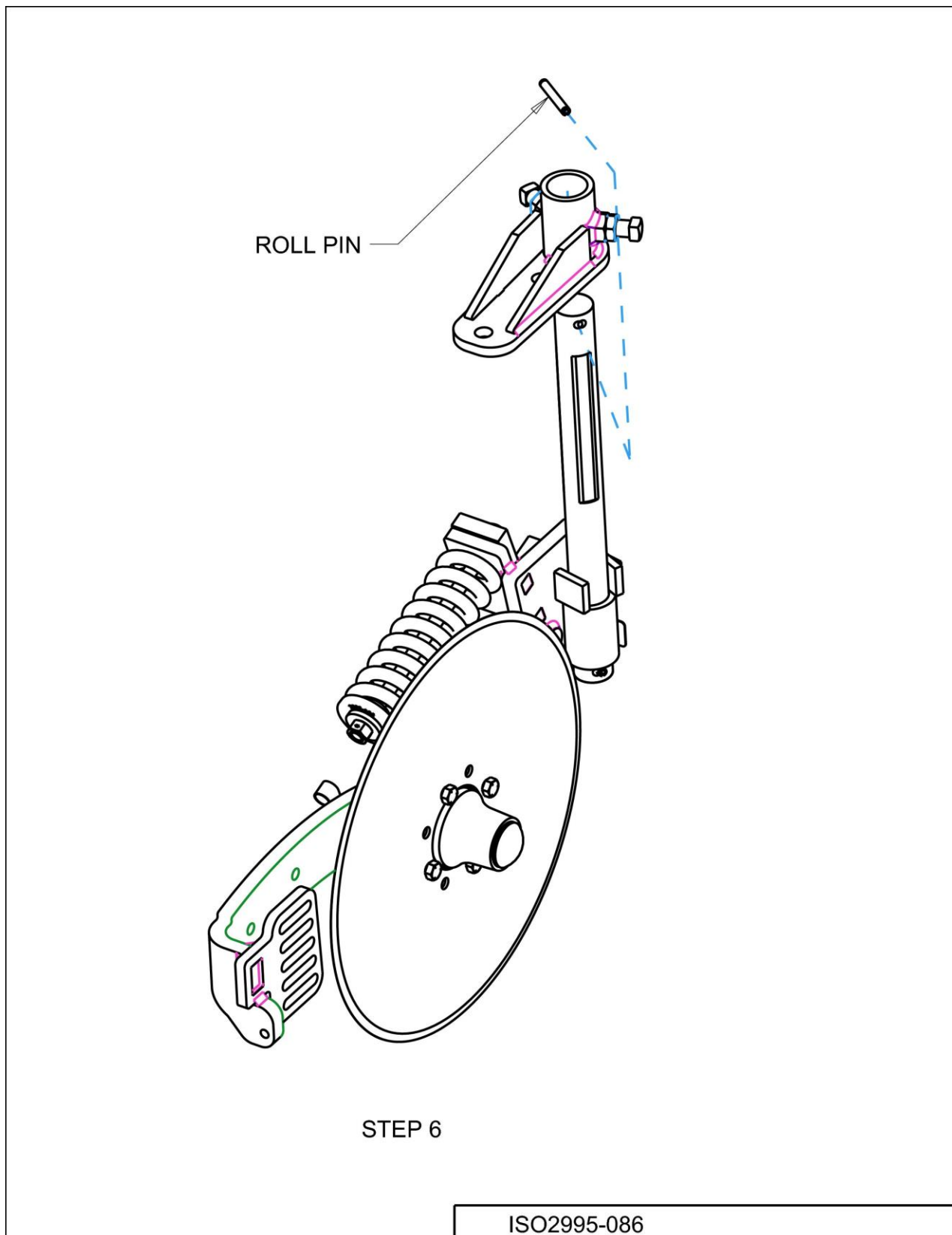

ASSEMBLY INSTRUCTIONS

STEP 7. Adjust coultter shank up or down as needed to securely tighten 2) set screws.

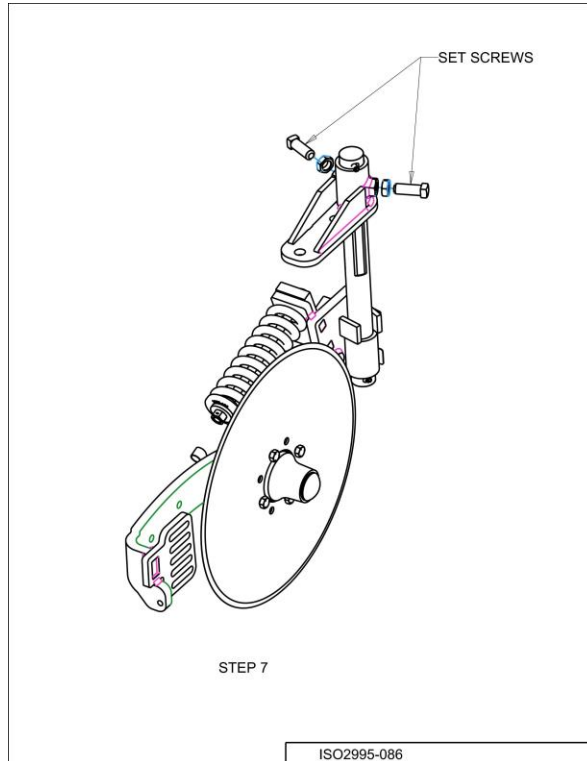

STEP 8. If using fertilizer, install the 2995-083 injector or 2995-084 knife as shown in the parts identification section of this manual.

NOTE: When installing the 2995-084 knife kit, bend the fertilizer tube slightly enough to allow clearance for the 2502-367 ½ x 4” knife lock bolt – see photo illustrations.

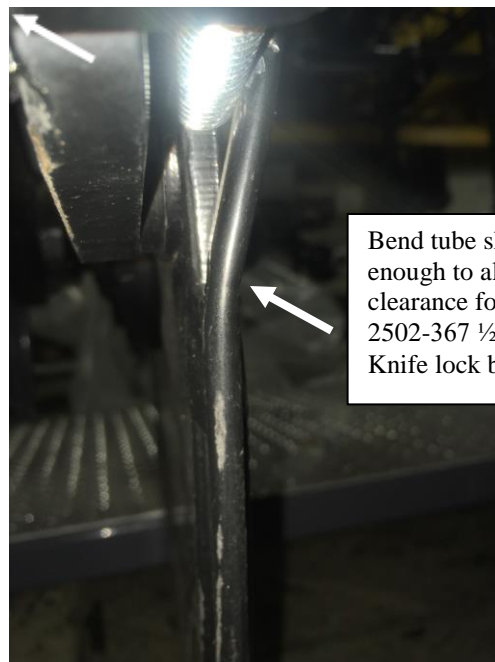
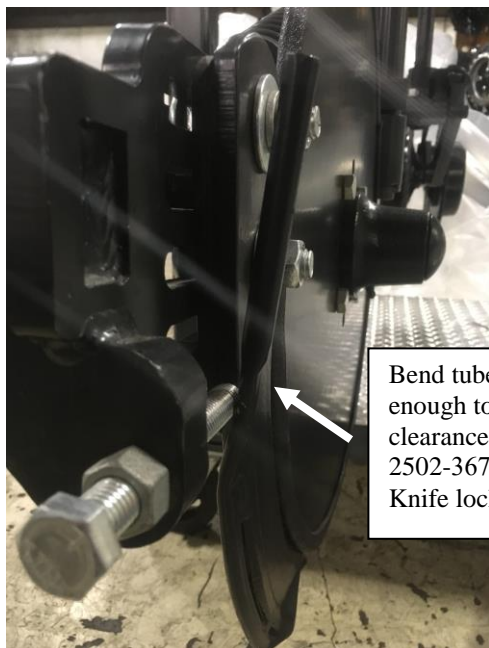

PARTS IDENTIFICATION

2995-086

FERTILIZER COULTER KIT

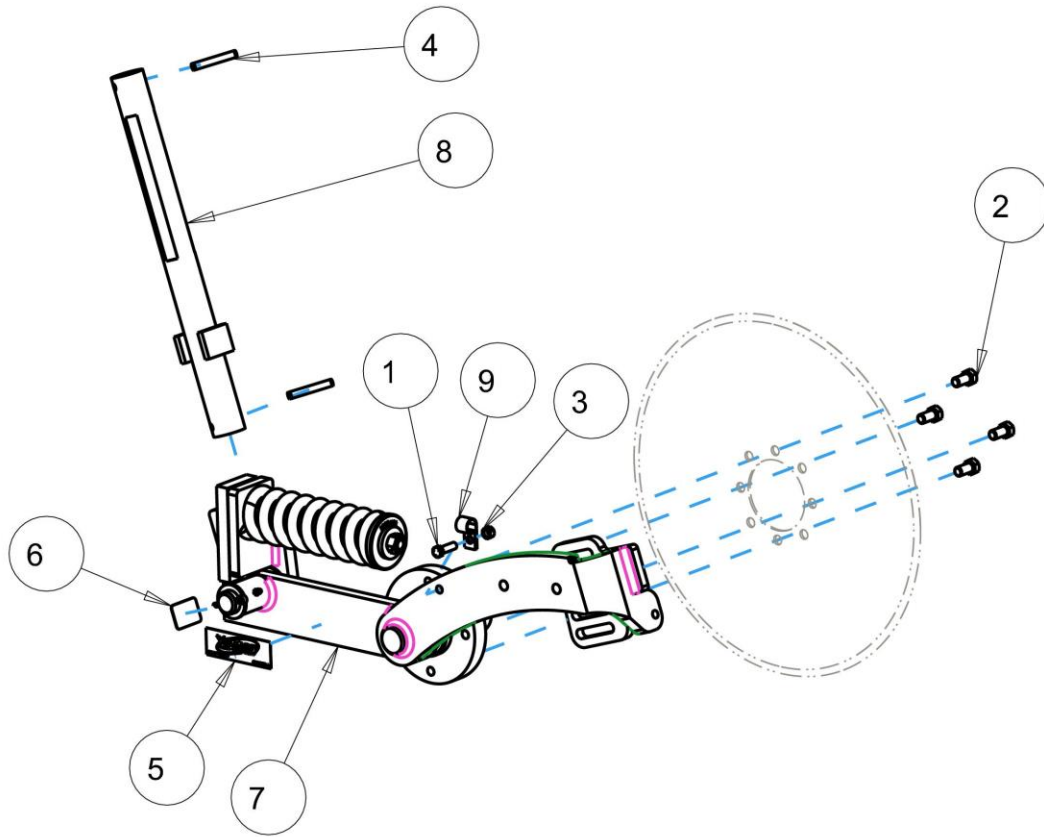

ITEM	PART #	DESCRIPTION	QTY
1	2502-244	3/8-16 X 1-1/4 HHCS GR 5 ZP	1
2	2502-344	1/2-20 X 1" HHCS	4
3	2520-255	3/8-16 LOCK HEX NUT, GR A, ZP	1
4	2530-208	3/8 X 2-1/2 ROLL PIN ZP	2
5	2565-162	YETTER DECAL	1
6	2565-832	'GREASE DAILY' DECAL	1
7	2995-197-RH	COULTER ASSEMBLY, RH	1
8	2995-243	20" COULTER SHANK W.A. (OPTIONAL)	1
-	2995-255	25" COULTER SHANK W.A. (OPTIONAL)	1
9	2995-429	5/8 x 13/32 HOSE P-CLIP	1

ISO2995-086

PARTS IDENTIFICATION

2995-086-L FERTILIZER COULTER KIT

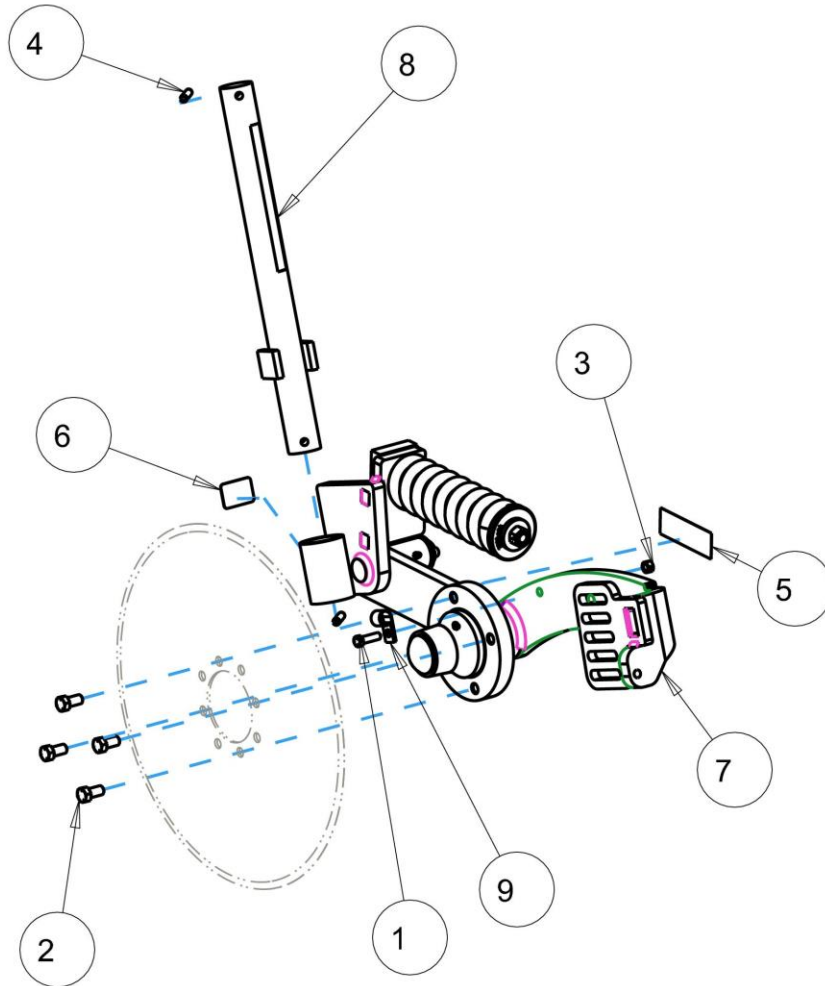

ITEM	PART #	DESCRIPTION	QTY
1	2502-244	3/8-16 X 1-1/4 HHCS GR 5 ZP	1
2	2502-344	1/2-20 X 1" HHCS	4
3	2520-255	3/8-16 LOCK HEX NUT, GR A, ZP	1
4	2530-208	3/8 X 2-1/2 ROLL PIN ZP	2
5	2565-162	YETTER DECAL	1
6	2565-832	'GREASE DAILY' DECAL	1
7	2995-197-LH	COULTER ASSEMBLY, LH	1
8	2995-243	20" COULTER SHANK W.A. (OPTIONAL)	1
-	2995-255	25" COULTER SHANK W.A. (OPTIONAL)	1
9	2995-429	5/8 x 13/32 HOSE P-CLIP	1

ISO2995-086

PARTS IDENTIFICATION COULTER ASSEMBLY 2995-197-RH

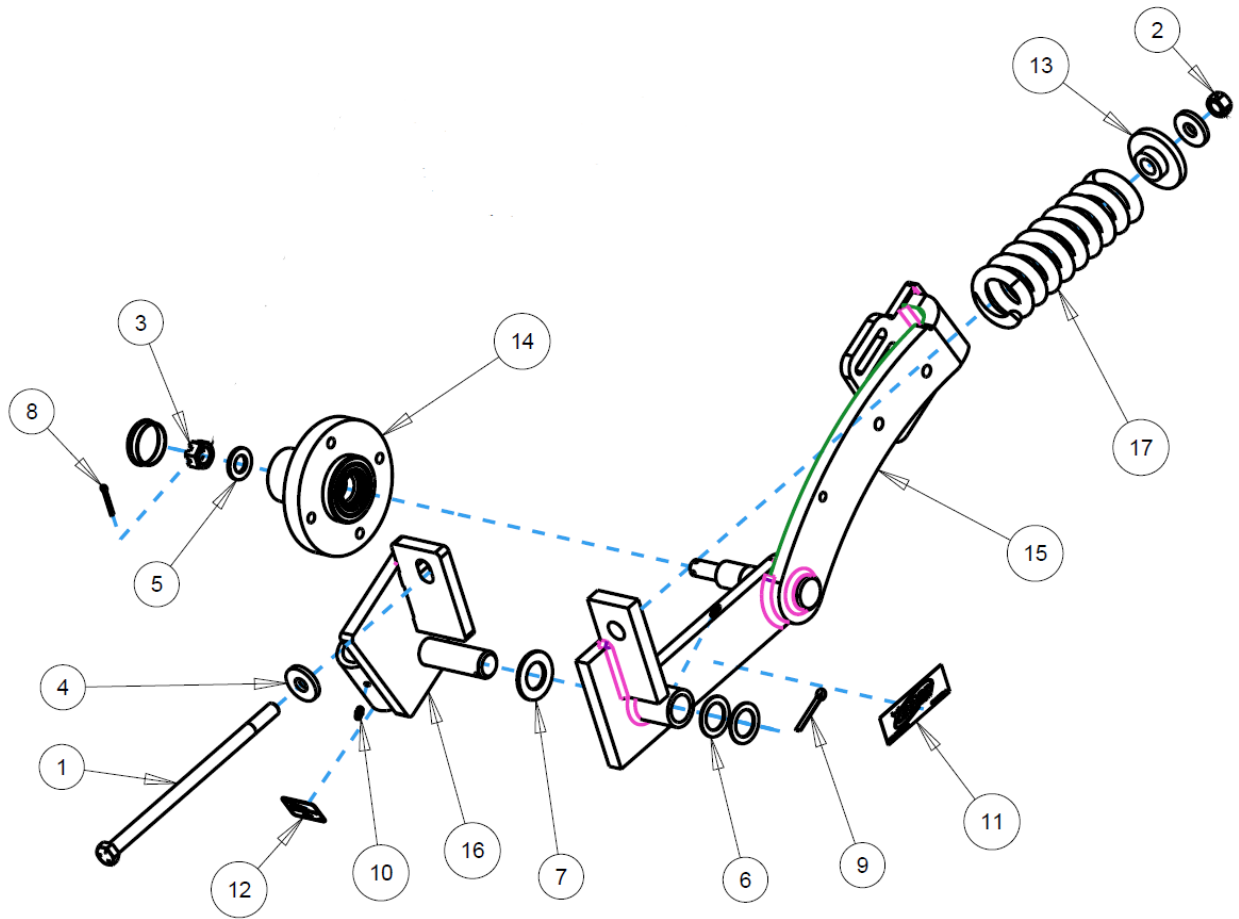

ITEM	PART NO.	DESCRIPTION	QTY
1	2502-337	5/8-11 X 12 HHCS GRADE 5	1
2	2520-459	5/8-11 LOCK NUT GRADE B	1
3	2520-503	3/4-16 SLOTTED HEX NUT GRADE 2	1
4	2526-449	5/8 FLAT WASHER 1/4" THICK	2
5	2526-504	3/4 SAE FLAT WASHER	1
6	2526-561	1-17/64 ID X 1-7/8 OD X 14 GAUGE MACHINE WASHER	3
7	2526-562	1-17/64 ID X 2-1/4 OD X 10 GAUGE MACHINE WASHER	1
8	2531-109	5/32 X 1-1/4 COTTER PIN	1
9	2531-125	1/4 X 1-3/4 COTTER PIN	1
10	2533-110	1/4-28 LUBE FITTING STRAIGHT SELF-TAP	2
11	2565-162	YETTER DECAL	1
12	2565-832	GREASE DAILY DECAL	1
13	2986-405	SPRING BUSHING	1
14	2995-138	633 HUB ASSEMBLY	1
	2533-110	1/4-28 LUBE FITTING STRAIGHT SELF-TAP	1
	2550-012	OUTER BEARING CONE LM11949	1
	2550-013	OUTER BEARING CUP LM11910	1
	2550-027	INNER BEARING CONE LM67048	1
	2550-029	INNER BEARING CUP LM67010	1
	2995-400	HUB	1
	2995-401	SEAL CR-14975	1
	2995-402	DUST CAP	1
15	2995-253-RH	RIGHT HAND ARM WITH KNIFE MOUNT	1
16	2995-254-RH	RIGHT HAND PIVOT	1
17	2995-403	SPRING	1

PARTS IDENTIFICATION COULTER ASSEMBLY LH 2995-197-LH

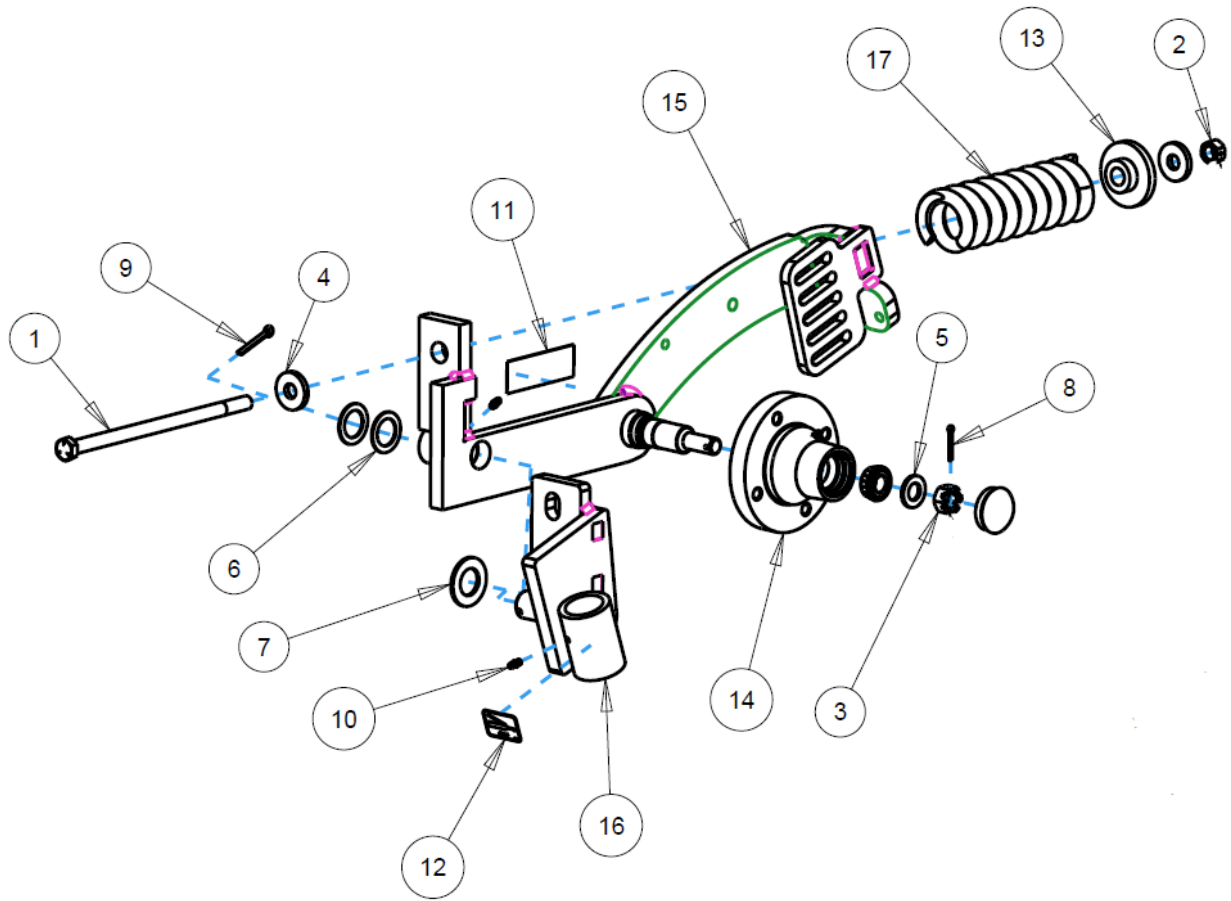

ITEM	PART NO.	DESCRIPTION	QTY
1	2502-337	5/8-11 X 12 HHCS GRADE 5	1
2	2520-459	5/8-11 LOCK NUT GRADE B	1
3	2520-503	3/4-16 SLOTTED HEX NUT GRADE 2	1
4	2526-449	5/8 FLAT WASHER 1/4" THICK	2
5	2526-504	3/4 SAE FLAT WASHER	1
6	2526-561	1-17/64 ID X 1-7/8 OD X 14 GAUGE MACHINE WASHER	3
7	2526-562	1-17/64 ID X 2-1/4 OD X 10 GAUGE MACHINE WASHER	1
8	2531-109	5/32 X 1-1/4 COTTER PIN	1
9	2531-125	1/4 X 1-3/4 COTTER PIN	1
10	2533-110	1/4-28 LUBE FITTING STRAIGHT SELF-TAP	2
11	2565-162	YETTER DECAL	1
12	2565-832	GREASE DAILY DECAL	1
13	2986-405	SPRING BUSHING	1
14	2995-138	633 HUB ASSEMBLY	1
	2533-110	1/4-28 LUBE FITTING STRAIGHT SELF-TAP	1
	2550-012	OUTER BEARING CONE LM11949	1
	2550-013	OUTER BEARING CUP LM11910	1
	2550-027	INNER BEARING CONE LM67048	1
	2550-029	INNER BEARING CUP LM67010	1
	2995-400	HUB	1
	2995-401	SEAL CR-14975	1
	2995-402	DUST CAP	1
15	2995-253-LH	LEFT HAND ARM WITH KNIFE MOUNT	1
16	2995-254-LH	LEFT HAND PIVOT	1

PARTS IDENTIFICATION

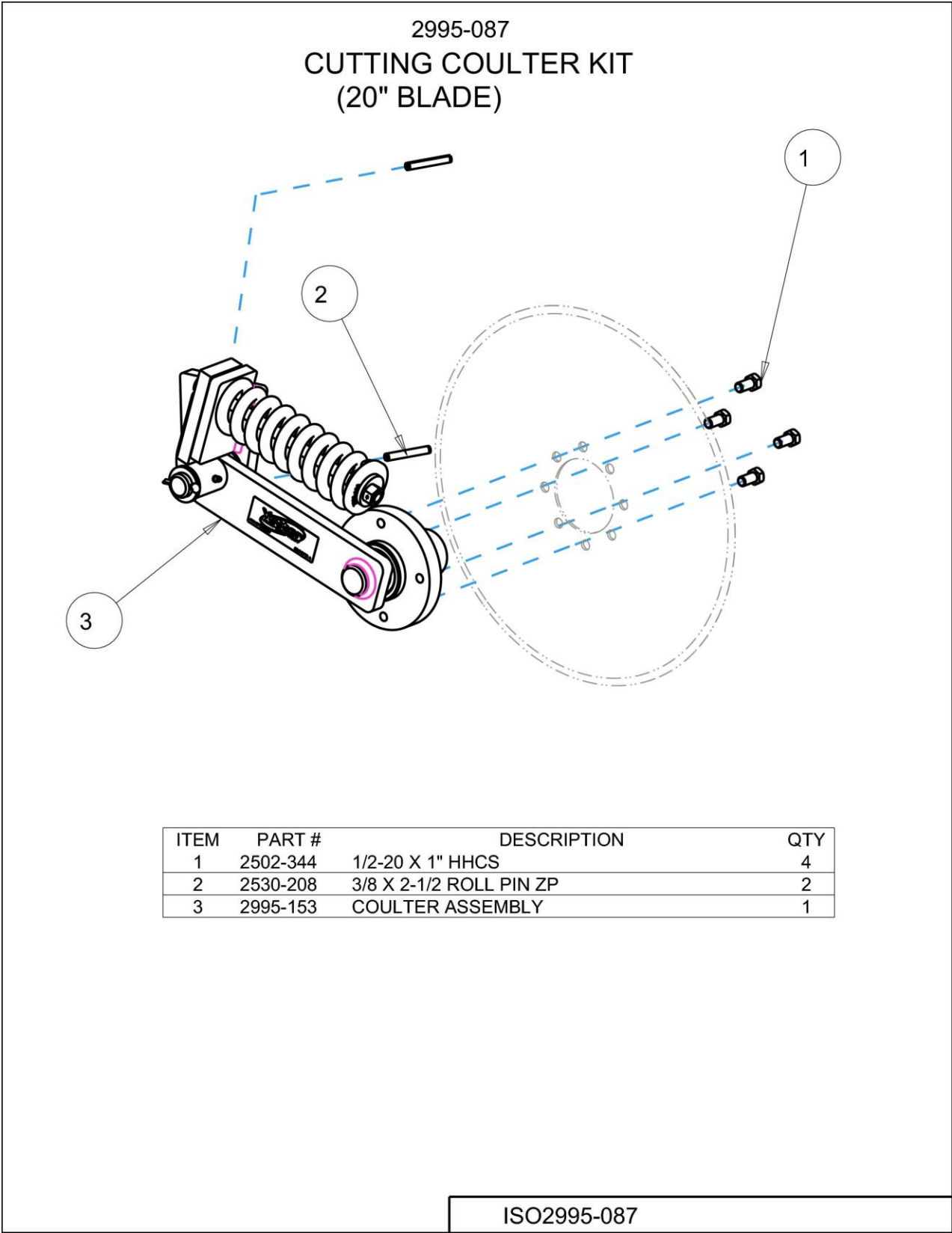

PARTS IDENTIFICATION COULTER ASSEMBLY 2995-153

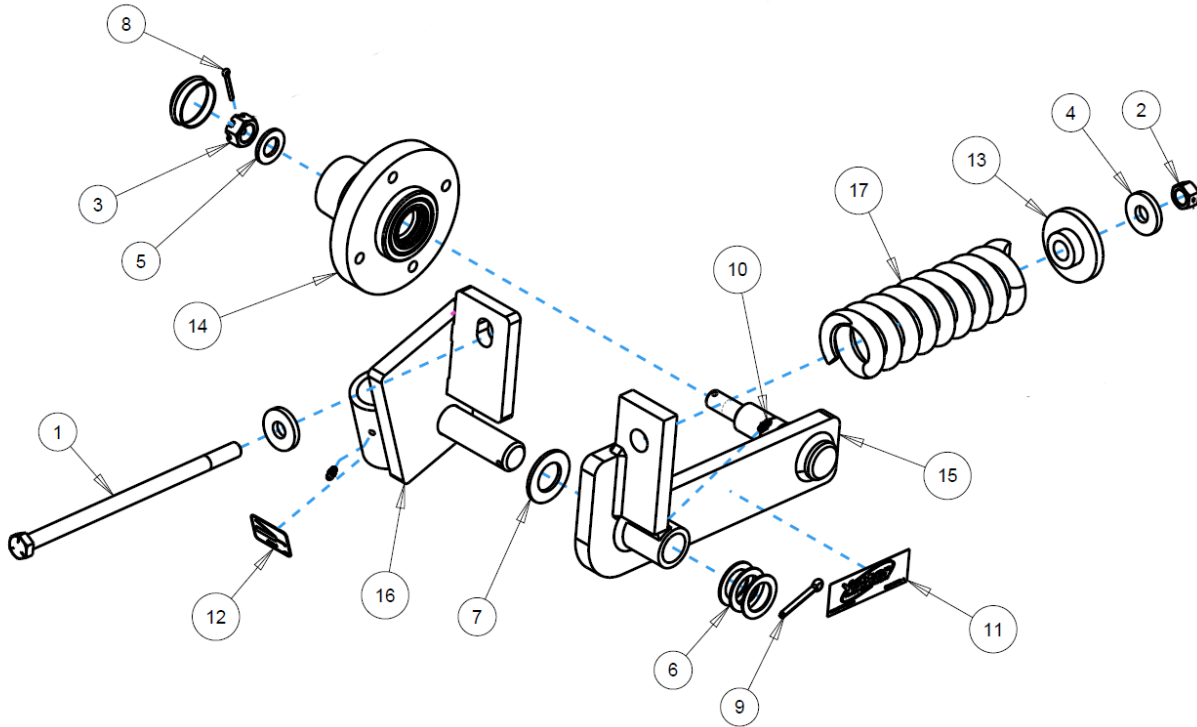

ITEM	PART NO.	DESCRIPTION	QTY
1	2502-337	5/8-11 X 12 HHCS GRADE 5	1
2	2520-459	5/8-11 LOCK NUT GRADE B	1
3	2520-503	3/4-16 SLOTTED HEX NUT GRADE 2	1
4	2526-449	5/8 FLAT WASHER 1/4" THICK	2
5	2526-504	3/4 SAE FLAT WASHER	1
6	2526-561	1-17/64 ID X 1-7/8 OD X 14 GAUGE MACHINE WASHER	3
7	2526-562	1-17/64 ID X 2-1/4 OD X 10 GAUGE MACHINE WASHER	1
8	2531-109	5/32 X 1-1/4 COTTER PIN	1
9	2531-125	1/4 X 1-3/4 COTTER PIN	1
10	2533-110	1/4-28 LUBE FITTING STRAIGHT SELF-TAP	2
11	2565-162	YETTER DECAL	1
12	2565-832	GREASE DAILY DECAL	1
13	2986-405	SPRING BUSHING	1
14	2995-138	633 HUB ASSEMBLY	1
	2533-110	1/4-28 LUBE FITTING STRAIGHT SELF-TAP	1
	2550-012	OUTER BEARING CONE LM11949	1
	2550-013	OUTER BEARING CUP LM11910	1
	2550-027	INNER BEARING CONE LM67048	1
	2550-029	INNER BEARING CUP LM67010	1
	2995-400	HUB	1
	2995-401	SEAL CR-14975	1
	2995-402	DUST CAP	1
15	2995-246	ARM	1
16	2995-254-RH	RIGHT HAND PIVOT	1
17	2995-403	SPRING	1

PARTS IDENTIFICATION

2995-089 CUTTING COULTER KIT (24" BLADE)

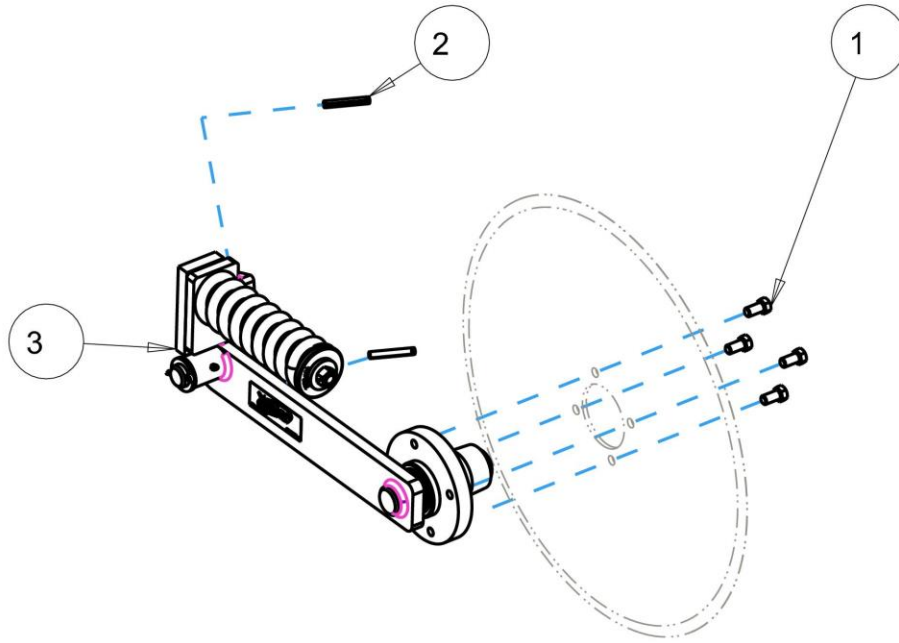

ITEM	PART #	DESCRIPTION	QTY
1	2502-344	1/2-20 X 1" HHCS	4
2	2530-208	3/8 X 2-1/2 ROLL PIN ZP	2
3	2995-149	COULTER ASSEMBLY	1

ISO2995-087

PARTS IDENTIFICATION

2995-149

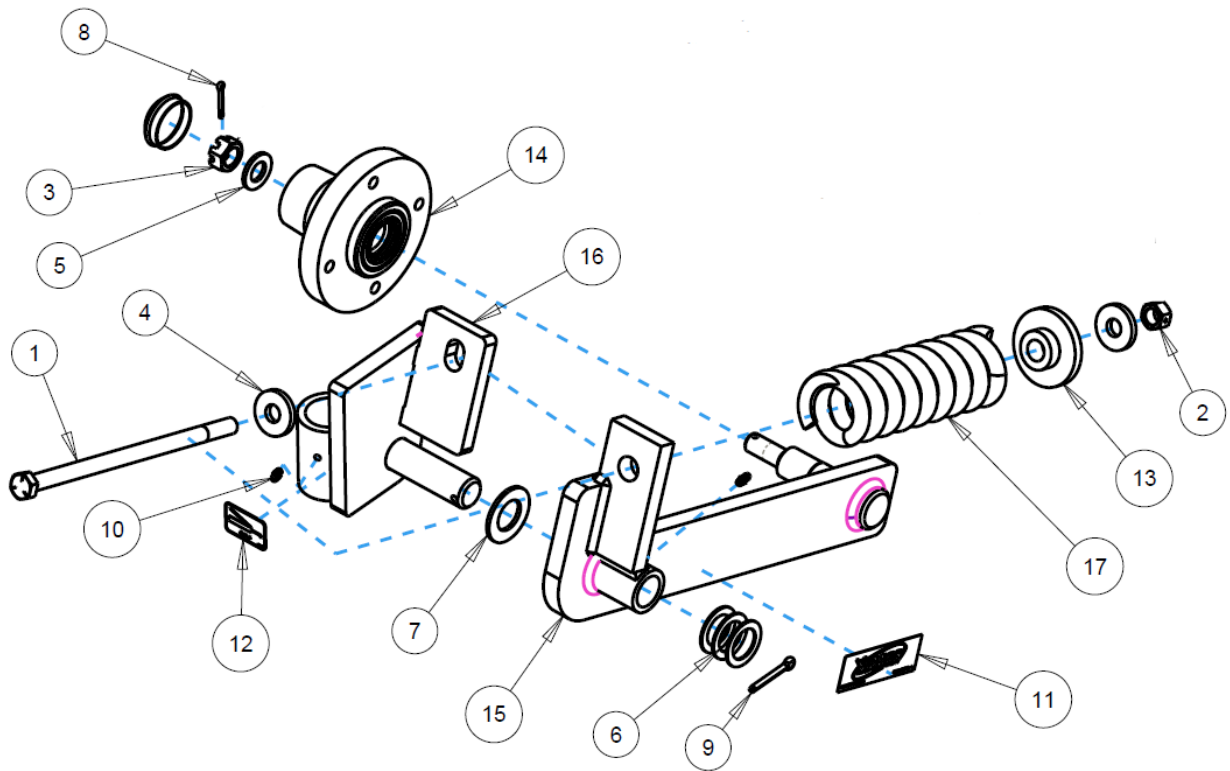

ITEM	PART NO.	DESCRIPTION	QTY
1	2502-337	5/8-11 X 12 HHCS GRADE 5	1
2	2520-459	5/8-11 LOCK NUT GRADE B	1
3	2520-503	3/4-16 SLOTTED HEX NUT GRADE 2	1
4	2526-449	5/8 FLAT WASHER 1/4" THICK	2
5	2526-504	3/4 SAE FLAT WASHER	1
6	2526-561	1-17/64 ID X 1-7/8 OD X 14 GAUGE MACHINE WASHER	3
7	2526-562	1-17/64 ID X 2-1/4 OD X 10 GAUGE MACHINE WASHER	1
8	2531-109	5/32 X 1-1/4 COTTER PIN	1
9	2531-125	1/4 X 1-3/4 COTTER PIN	1
10	2533-110	1/4-28 LUBE FITTING STRAIGHT SELF-TAP	2
11	2565-162	YETTER DECAL	1
12	2565-832	GREASE DAILY DECAL	1
13	2986-405	SPRING BUSHING	1
14	2995-138	633 HUB ASSEMBLY	1
	2533-110	1/4-28 LUBE FITTING STRAIGHT SELF-TAP	1
	2550-012	OUTER BEARING CONE LM11949	1
	2550-013	OUTER BEARING CUP LM11910	1
	2550-027	INNER BEARING CONE LM67048	1
	2550-029	INNER BEARING CUP LM67010	1
	2995-400	HUB	1
	2995-401	SEAL CR-14975	1
	2995-402	DUST CAP	1
15	2995-248	ARM	1
16	2995-254-RH	RIGHT HAND PIVOT	1
17	2995-403	SPRING	1

PARTS IDENTIFICATION

2995-138

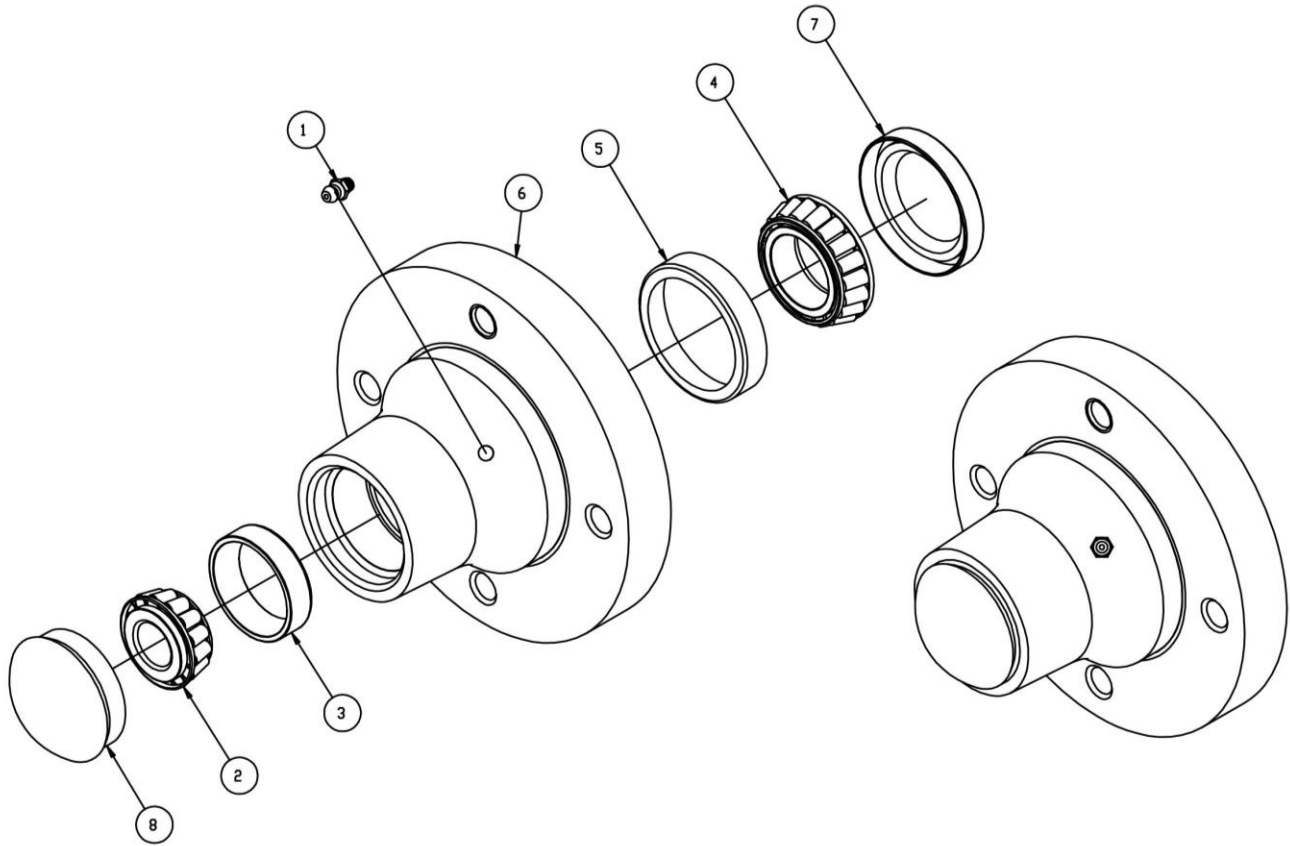

ITEM	PART NO	DESCRIPTION	QTY
1	2533-110	1/4-28 ZERK STRAIGHT SELF-TAP	1
2	2550-012	CONE W.G. (LM11949)	1
3	2550-013	CUP W.G. (LM11910)	1
4	2550-027	CONE, LM67048	1
5	2550-029	CUP, LM67010	1
6	2995-400	633 HUB, MACHINED	1
7	2995-401	SEAL, CR #14975	1
8	2995-402	HUB CAP, 633 HUB	1

PARTS IDENTIFICATION

2995-083 INJECTOR KIT

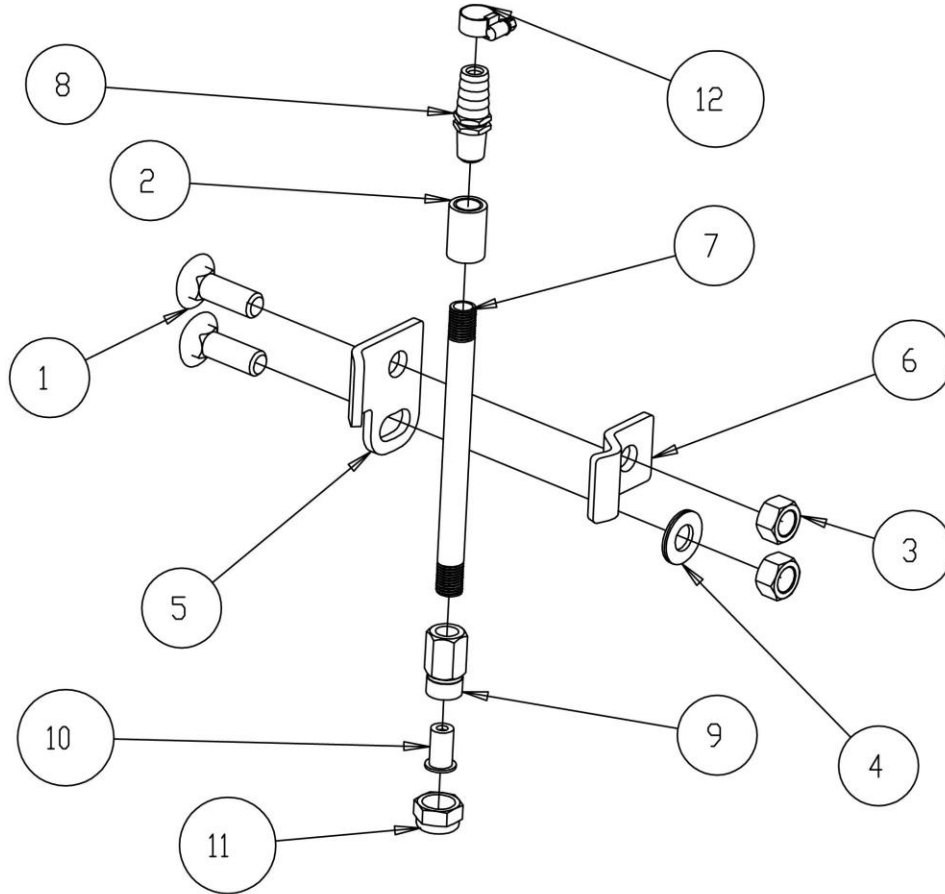

ITEM	PART #	DESCRIPTION	QTY
1	2505-340	1/2"-13 X 1-1/2" BOLT-STAINLESS STEEL	2
2	2515-312	1/4" NPT COUPLER-STAINLESS STEEL	1
3	2520-353	1/2"-13 HEX NUT-STAINLESSS STEEL	2
4	2526-352	1/2" SAE FLATWASHER	1
5	2995-404	INJECTOR RETAINER	1
6	2995-405	INJECTOR CLAMP	1
7	2995-406	1/4" NPT X 6" PIPE NIPPLE	1
8	2995-407	HOSE BARB	1
9	2995-408	NOZZLE BODY	1
10	2995-409	CHECK VALVE	1
11	2995-410	TIP RETAINER	1
12	2995-411	HOSE CLAMP-STAINLESS STEEL	1

ISO2995-083

PARTS IDENTIFICATION

2995-084

WIESE CO501000 FERTILIZER KNIFE KIT

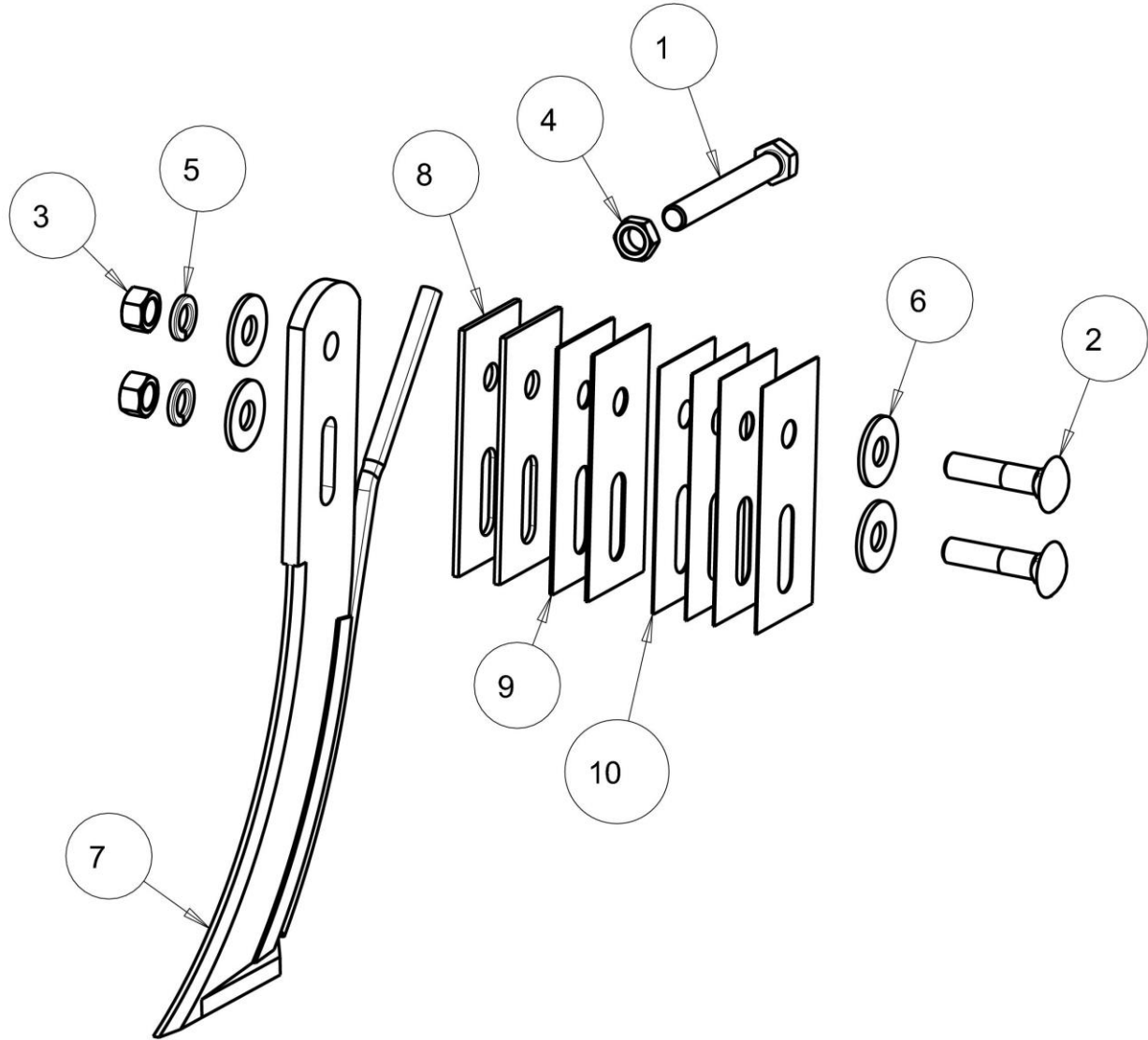

ITEM	PART #	DESCRIPTION	QTY
1	2502-367	1/2-13 X 4 FULL THRD HHCS GR5	1
2	2505-341	1/2-13 X 2-1/4 RHSN BOLT, 18-8 SS	2
3	2520-352	1/2-13 HEX NUT, GR 2, ZP	2
4	2520-356	1/2-13 JAM HEX NUT ZP	1
5	2525-352	1/2 MED LOCKWASHER ZP	2
6	2526-351	1/2 STANDARD FLATWASHER ZP	4
7	2995-412	WIESE CO501000 FERTILIZER KNIFE	1
8	2995-413	KNIFE SHIM, .12" THICK	2
9	2995-414	KNIFE SHIM, .06" THICK	2
10	2995-415	KNIFE SHIM, .03" THICK	4

ISO-2995-084

PARTS IDENTIFICATION

2995-081
 4", 5" & 7" OFFSET BRACKET

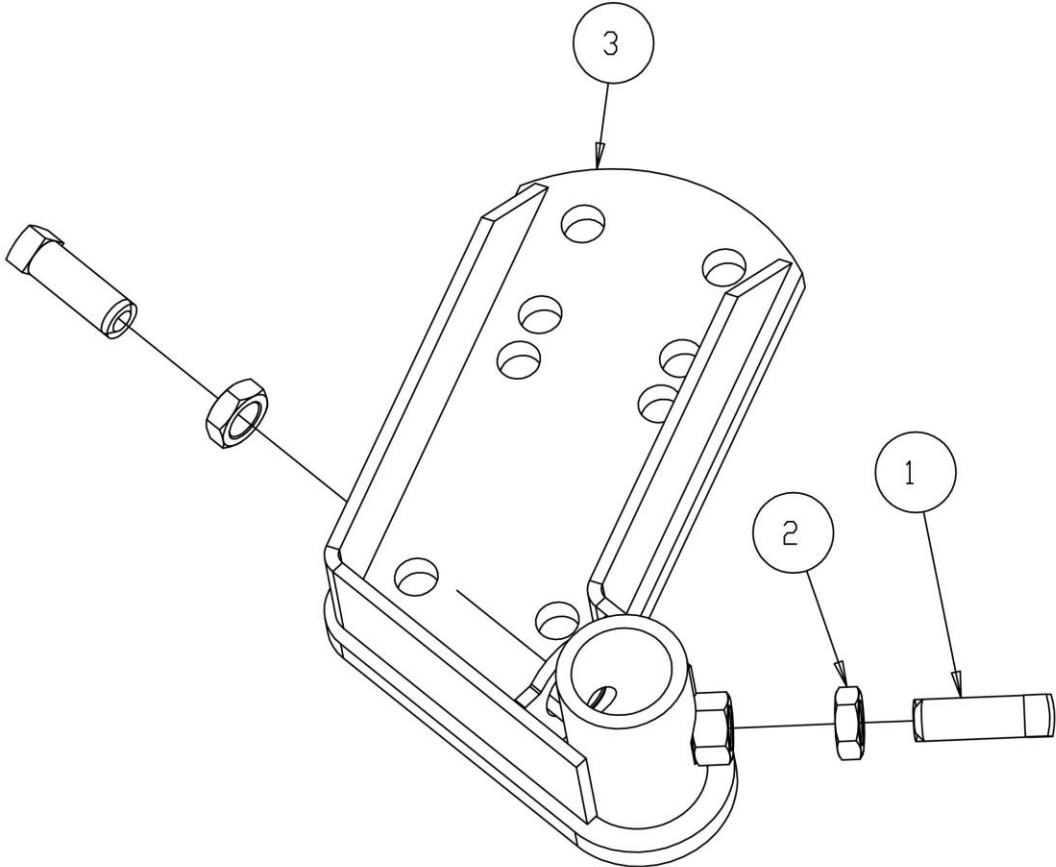

ITEM	PART #	DESCRIPTION	QTY
1	2503-400	SET SCREW 3/4" X 2"	2
2	2520-502	3/4-10 HEX JAM NUT	2
3	2995-241	OFFSET MOUNT	1

ISO2995-081

PARTS IDENTIFICATION

2995-082
4", 5" & 7" RIGID C-SHANK MOUNT

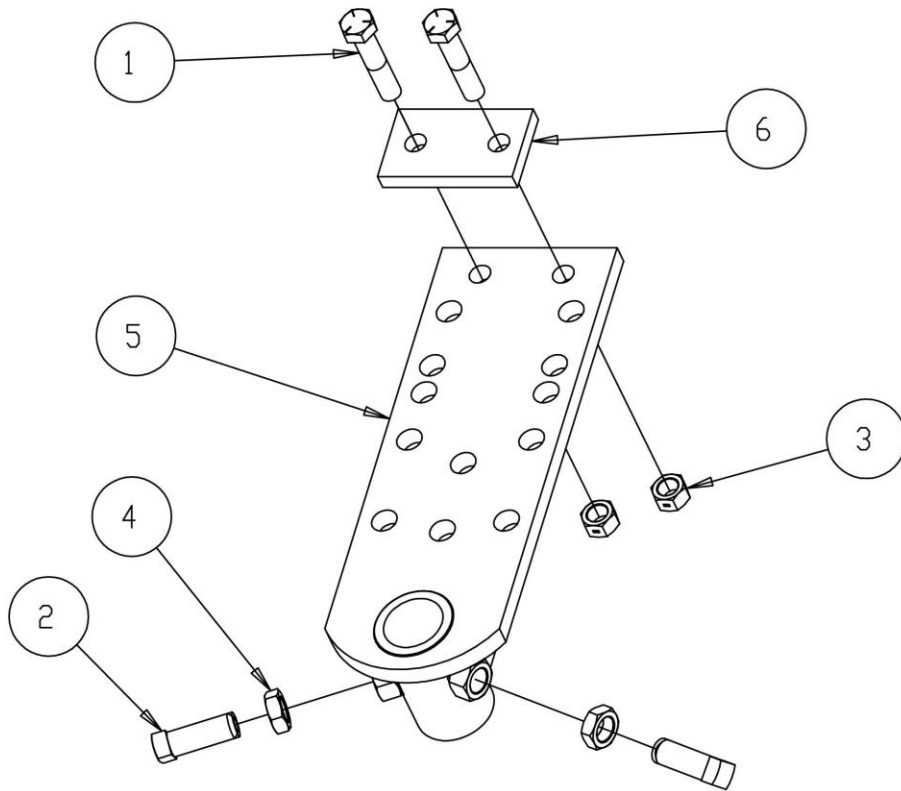

ITEM	PART #	DESCRIPTION	QTY
1	2502-325	5/8"-11 X 3" HHCS GR 5	2
2	2503-400	SET SCREW 3/4" X 2"	2
3	2520-459	5/8"-11 LOCK HEX NUT	2
4	2520-502	3/4"-10 HEX JAM NUT	2
5	2995-242	RIGID C-SHANK MOUNT	1
6	2995-387	CLAMP PLATE	1

ISO2995-082

PARTS IDENTIFICATION

2995-088
7" RIGID MOUNT BRACKET

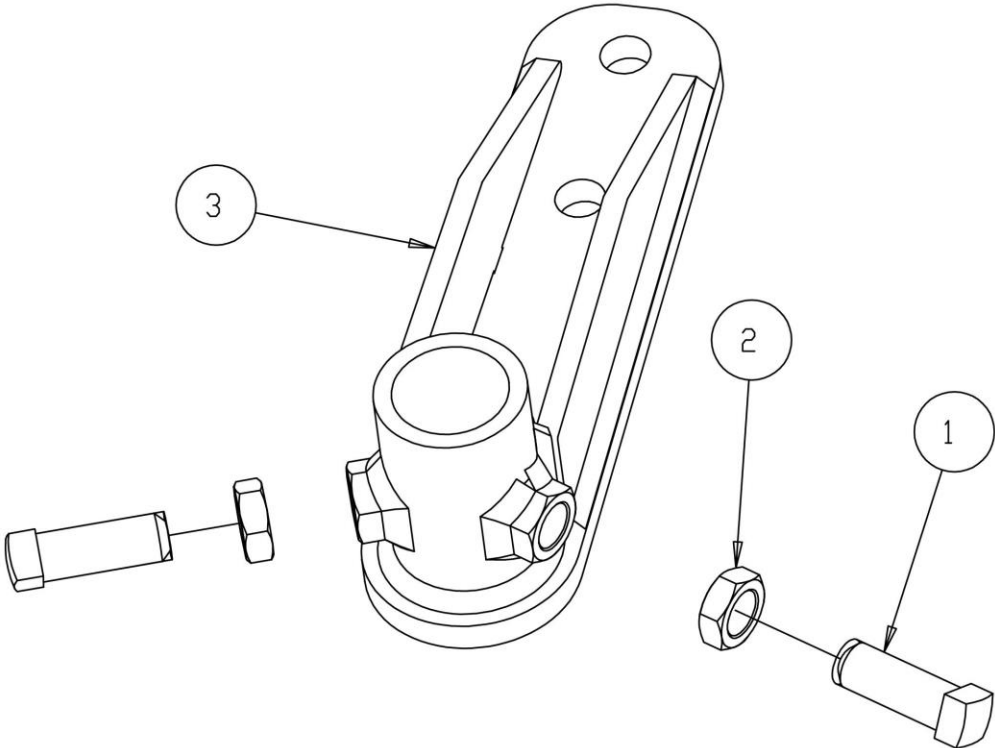

ITEM	PART #	DESCRIPTION	QTY
1	2503-400	SHSS, CUP POINT, .75-10 X 2, ZP	2
2	2520-502	3/4-10 HEX JAM NUT ZYD	2
3	2995-247	7" MOUNT WELD ASSEMBLY	1

ISO2995-088

PARTS IDENTIFICATION

2995-099
5" RIGID MOUNT BRACKET

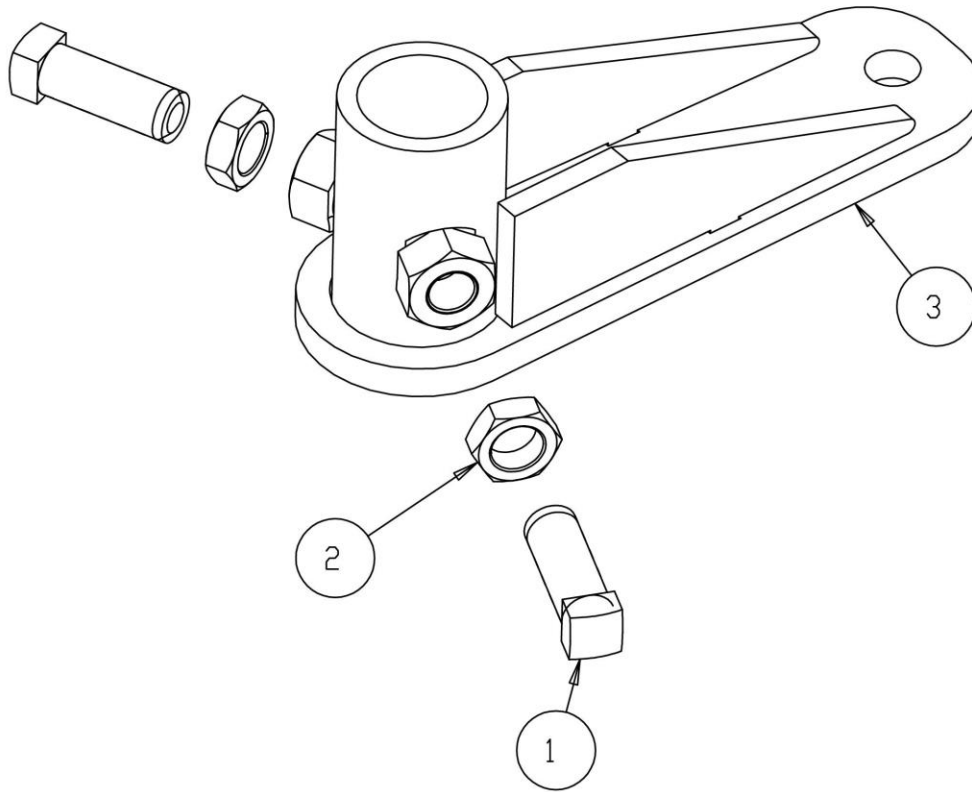

ITEM	PART #	DESCRIPTION	QTY
1	2503-400	SHCPSS, .75-10 X 2, ZP	2
2	2520-502	3/4-10 HEX JAM NUT ZYD	2
3	2995-252	5" MOUNT W.A.	1

ISO-2995-099

TROUBLESHOOTING

<u>Problem</u>	<u>Cause</u>	<u>Solution</u>
Residue plugging knife	Knife not correctly aligned behind blade	Use shims to align knife behind blade
Blade not penetrating	Insufficient pressure coulter spring	Tighten coulter spring locknut
Fertilizer too shallow	Coulter incorrectly adjusted Toolbar is too high	Adjust height of coulter by sliding shank down Lower toolbar
Fertilizer too deep	Coulter incorrectly adjusted Too low toolbar	Adjust height of coulter by sliding shank up Raise toolbar
Fertilizer will not flow	Plugged fertilizer tubes	Check for plugged fertilizer tube openings on knife Check for plugged fertilizer delivery tubes on toolbar

NOTES:

NOTES:

NOTES:

NOTES:

Our name Is getting known

Just a few years ago, Yetter products were sold primarily to the Midwest only. Then we embarked on a program of expansion and moved into the East, the South, the West and now north into Canada. We're even getting orders from as far away as Australia and Africa.

So, when you buy Yetter products . . .you're buying a name that's recognized. A name that's known and respected. A name that's become a part of American agriculture and has become synonymous with quality and satisfaction in the field of conservation tillage.

Thank you.

YETTER MANUFACTURING CO.
Colchester, IL 62326-0358 ☎ 309/776-4111
Toll Free 800/447-5777
Fax 309/776-3222
Website: www.yetterco.com
E-mail: info@yetterco.com