



2967-042B

TITAN™

**RESIDUE MANAGER
FOR
JOHN DEERE HD COULTER**

**OPERATOR'S MANUAL
PART IDENTIFICATION**

2565-955_REV_E • 08/2023



YETTER MANUFACTURING CO.
FOUNDED 1930

Colchester, IL 62326-0358
Toll free: 800/447-5777
309/776-3222 (Fax)
Website: www.yetterco.com
E-mail: info@yetterco.com

YETTER

FOREWORD

You've just joined an exclusive but rapidly growing club.

For our part, we want to welcome you to the group and thank you for buying a Yetter product.

We hope your new Yetter products will help you achieve both goals-increase your productivity and increase your efficiency so that you may generate more profit.

This operator's manual has been designed into four major sections: Foreword, Safety Precautions, Installation Instructions and Parts Breakdown.



This **SAFETY ALERT SYMBOL** indicates important safety messages in the manual. When you see this symbol, be alert to the possibility of **PERSONAL INJURY** and carefully read the message that follows.

The word **NOTE** is used to convey information that is out of context with the manual text. It contains special information such as specifications, techniques and reference information of a supplementary nature.

The word **IMPORTANT** is used in the text when immediate damage will occur to the machine due

to improper technique or operation. Important will apply to the same information as specified by note only of an immediate and urgent nature.

It is the responsibility of the user to read the operator's manual and comply with the safe and correct operating procedure and to lubricate and maintain the product according to the maintenance schedule in the operator's manual.

The user is responsible for inspecting his machine and for having parts repaired or replaced when continued use of the product would cause damage or excessive wear to the other parts.

It is the user's responsibility to deliver his machine to the Yetter dealer who sold him the product for service or replacement of defective parts, which are covered by the warranty policy.

If you are unable to understand or follow the instructions provided in this publication, consult your local Yetter dealer or contact:

YETTER MANUFACTURING CO.

309/776-4111

800/447-5777

309/776-3222 (FAX)

Website: www.yetterco.com

E-mail: info@yetterco.com

WARRANTY

Yetter Manufacturing warrants all products manufactured and sold by it against defects in material. This warranty being expressly limited to replacement at the factory of such parts or products as shall appear to be defective after inspection. This warranty does not obligate the Company to bear cost of labor in replacement of parts. It is the policy of the Company to make improvements without incurring obligations to add them to any unit already sold. No warranty is made or authorized to be made, other than herein set forth. This warranty is in effect for one year after purchase.

DEALER: _____

Yetter Manufacturing warrants its own products only and cannot be responsible for damages to equipment on which mounted.

SAFETY

A brief description of signal words that may be used in this manual:

CAUTION: Used as a general reminder of good safety practices or to direct attention to unsafe practices.

WARNING: Denotes a specific potential hazard.

DANGER: Denotes the most serious specific potential hazard.

SAFETY PRECAUTIONS

You can make your farm a safer place to live and work if you observe the safety precautions given. Study these precautions carefully and insist that those working with you and for you follow them.

Finally, remember this: an accident is usually caused by someone's carelessness, neglect or oversight.



WARNING

Never clean, lubricate or adjust a machine that is in motion. Always lower or block the implement before performing service.

If the machine must be serviced in the raised position, jack or block it up to prevent it from accidentally falling and injuring someone.

Do not allow riders on the tractor or implement.

Use speeds and caution dictated by the terrain being traversed. Do not operate on any slope steep enough to cause tipping or loss of control.

Be sure all personnel are clear of the immediate area before operating.

Read and understand the operator's manual and require all other persons who will operate the equipment to do the same.

Be familiar with all tractor and implement controls and be prepared to stop engine and implements quickly in an emergency.



CAUTION

Consult your implement and tractor operator's manual for correct and safe operating practices.

Beware of towed implement width and allow safe clearance.

FAILURE TO HEED MAY RESULT IN PERSONAL INJURY OR DEATH.

TABLE OF CONTENTS

FOREWORD.....	2
SAFETY	3
BOLT TORQUE	5
INSTALLATION INSTRUCTIONS	6-7
OPERATION.....	8
MAITENANCE	9
PART IDENTIFICATION.....	10-17

BOLT TORQUE

Before operating the Titan™ Residue Manager for the first time, check to be sure that all hardware is properly torqued. Check all hardware again after approximately 50 hours of operation and at the beginning of each planting season.

If hardware must be replaced, be sure to replace it with hardware of the equal size, strength, and thread type. Refer to the torque table when tightening hardware.

IMPORTANT: Over tightening hardware can cause as much damage as under tightening. Tightening hardware beyond the recommended range can reduce its shock load capacity.









The chart below is a guide for proper torque. Use it unless a specified torque is called out elsewhere in the manual.

Torque is the force applied to the wrench handle or cheater bar, times the length of the handle or bar.

USE A TORQUE WRECH WHEREVER POSSIBLE.

The top table shows torque values for standard hardware and the bottom shows values for metric hardware.

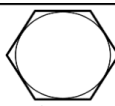
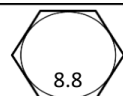
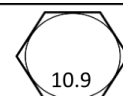
Standard				
Bolt Diameter and Threads per Inch				
	Grade 2	Grade 5	A-325	Grade 8
Units	ft-lbs	ft-lbs	ft-lbs	ft-lbs
1/4	6		10	14
5/16	12		20	30
3/8 – 16	25		35	50
7/16 – 14	35		55	80
1/2 – 13	55		85	125
9/16 – 12	75		125	175
5/8 – 11	105		170	235
3/4-10	185		305	425
7/8 – 9	170		445	690
1-8	260		670	1030
1 1/8 – 7	365		900	1460
1 1/4 - 7	515		1275	2060
1 3/8 – 6	675		1675	2700
1 1/2 - 6	900		2150	3500
1 3/4 – 5	1410		3500	5600

Metric				
Size				
	Class 4.8	Class 8.8	Class 10.9	Class 12.9
Units	N-m(ft-lbs)	N-m(ft-lbs)	N-m(ft-lbs)	N-m(ft-lbs)
M3	0.60(.500)	-	-	-
M4	1.20(1.00)	-	-	-
M5	2.40(2.00)	4.55(3.50)	6.65(5.00)	7.7(5.68)
M6	4.20(3.00)	8.15(6.00)	11.5(8.50)	13.5(10.0)
M8	10.1(7.50)	20.7(15.3)	25.55(18.8)	32.7(24.1)
M10	20.0(14.7)	40.9(30.2)	54.7(40.4)	64.5(47.6)
M12	-	67.5(49.8)	95.5(70.4)	111(81.9)
M14	-	106(78.2)	151(111)	177(130)
M16	-	166(122)	235(173)	275(203)
M20	-	323(238)	460(339)	538(397)
M22	-	435(320)	619(456)	724(534)
M24	-	555.5(409)	791(583)	925(682)
M30	-	1110(818)	1580(1160)	1850(1360)
M36	-	1930(1420)	2750(2020)	3220(2370)

INSTALLATION INSTRUCTIONS

STEP 1. Install the 2966-111 mount bracket and the JD coultter using the M12 X 45MM locknuts.

Tighten the bolts snug where the coultter can be moved as needed

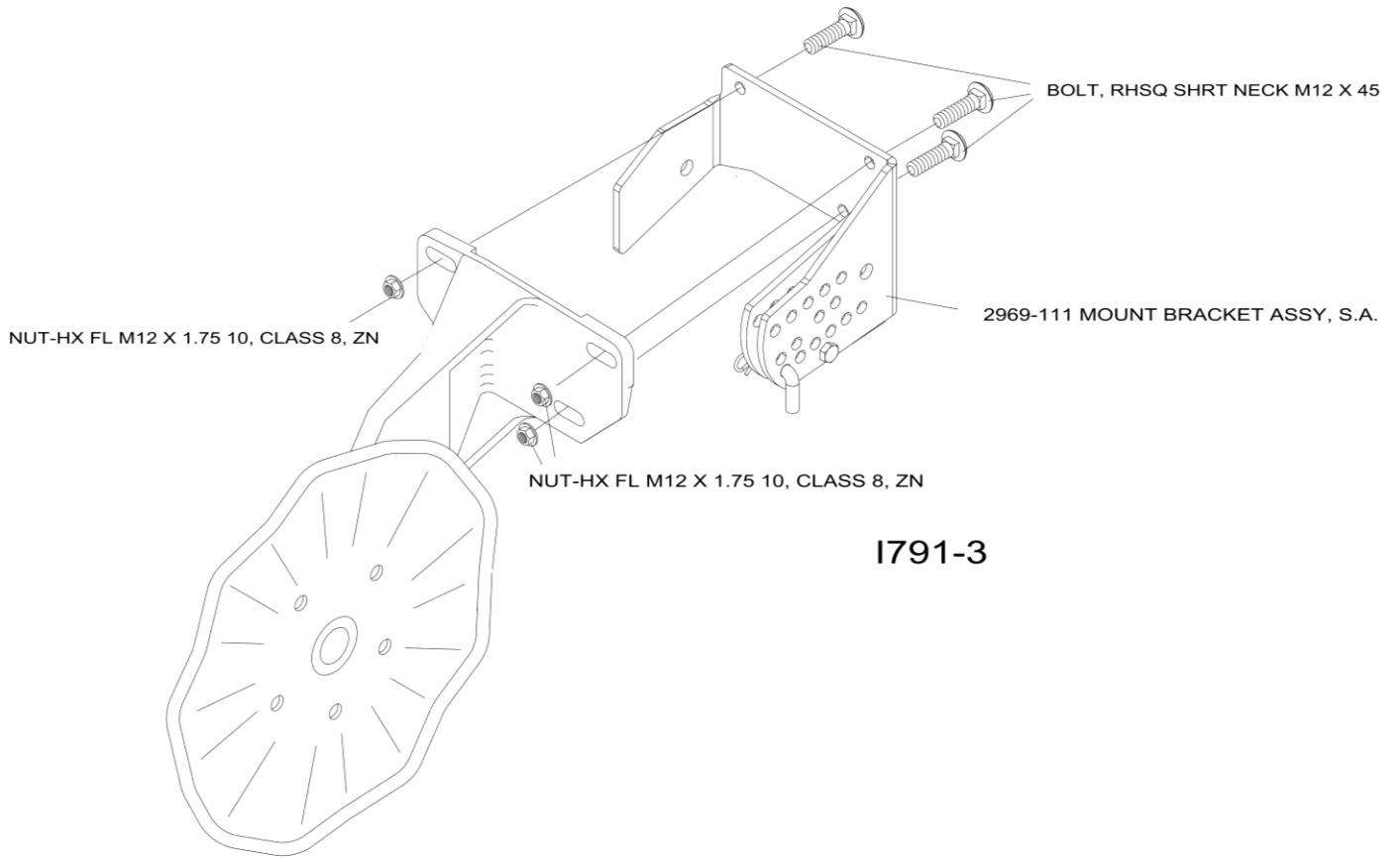

I791-3

INSTALLATION INSTRUCTIONS

STEP 2. Attach the residue manager arm/wheel assembly using the M16 X 45 Hex Flange Screw, bushing, and locknuts.

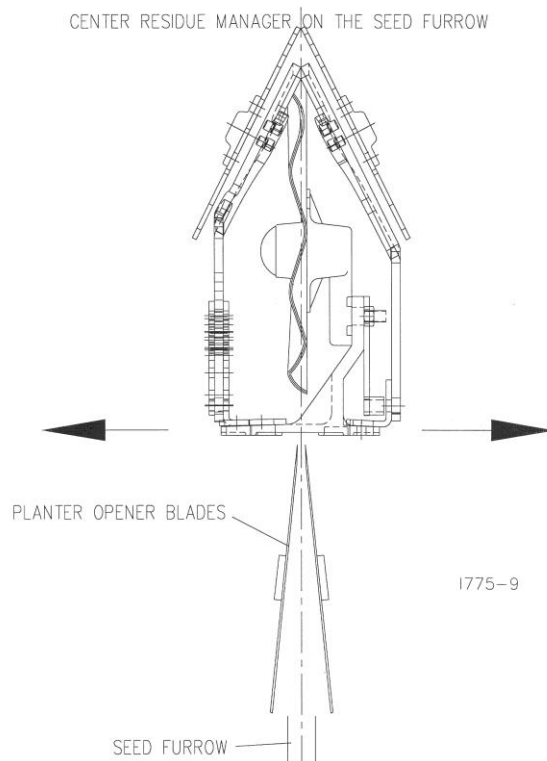
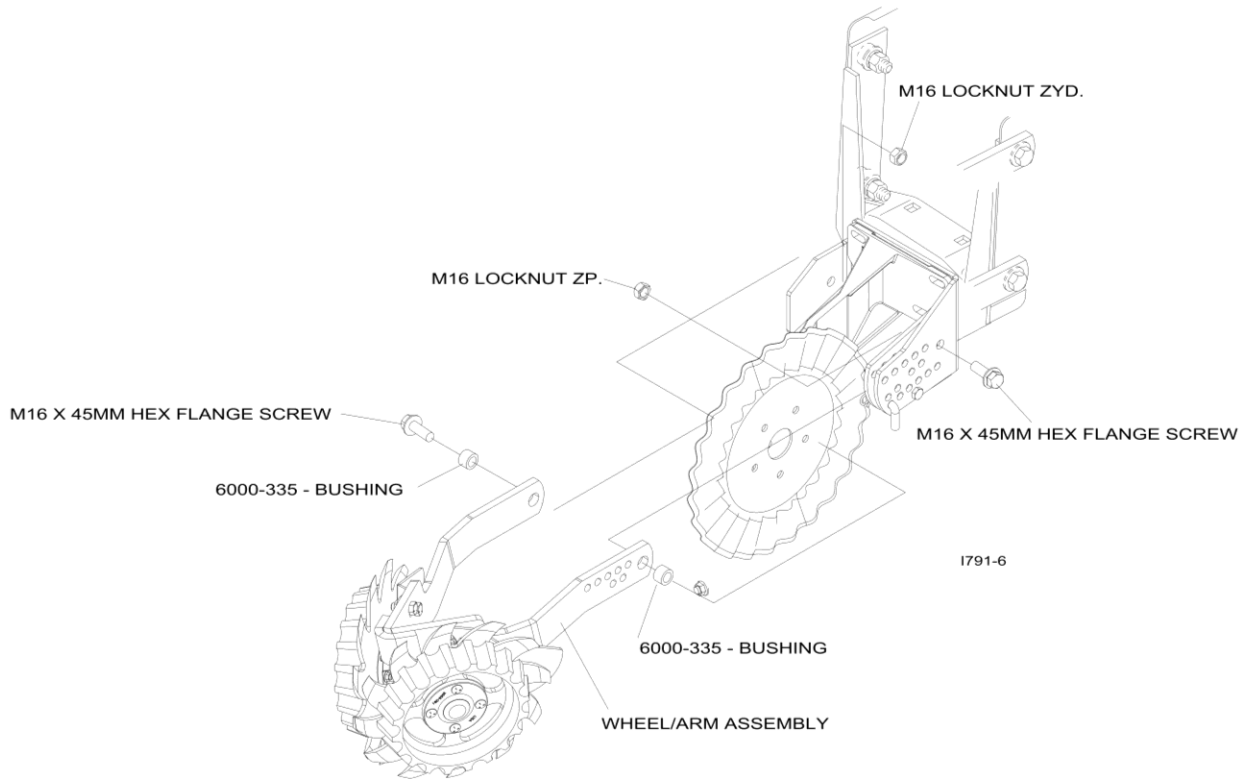

OPERATION

CAUTION: Where rocks are present the residue manager should be set in the “float” position, not locked down.

STEP 1. Adjust the residue manager to move crop residue aside and not move any soil. Adjustments to the residue manager may have to be made when changing field conditions and type and amount of residue. Use the handle for leverage when changing depth settings.

“FLOAT SETTINGS”

Install the adjustment pin below the combo arm.

“RIGID SETTING”

Install the adjustment pin through the combo arm.

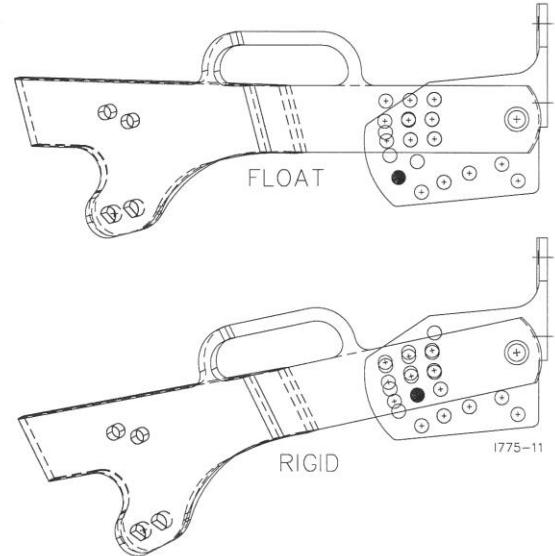

ROW CLEANER DO'S AND DON'TS

1. **DO NOT** move soil; Residue Managers are designed to move crop residue only.
2. **DO NOT** operate planter at slow speeds, ground speed affects how aggressive the spoke wheels are; operate at sufficient speed (4-6 mph) to maintain good residue flow.
3. **DO NOT** expect 100% of crop residue to be cleared, it is not necessary and would necessitate engaging the soil. The width of path cleared depends on ground conditions, depth setting and ground speed.
4. **DO** expect to see wheels occasionally quit turning, indicates ideal (shallow) setting which is not moving soil.

DO adjust toolbar frame height 20”-22” and drawbar to “level” correctly. Very important to ensure planter opener will follow ground contours properly.

IMPORTANT: For proper operation, the planter frame must operate level (for, aft and side to side) and at the correct height, typically 20”-22”.

MAINTENANCE

Storing the Equipment

Store the machine in an area away from human activity

Store machine in RAISED position.

Install service locks on all wheel cylinders.

At the end of the season, the machine should be thoroughly inspected and prepared for storage. Repair or replace any worn or damaged components to prevent down time at the start of the next season. Store machine under cover with all parts in operating condition.

- Clean machine thoroughly to remove all dirt, debris and crop residue, which would hold moisture and cause rusting.
- Inspect machine for worn or broken parts. See your Yetter Farm Equipment dealer during the off-season so that parts or service can be acquired when machine is not needed in the field.
- Lubricate bearings as outlined in the Lubrication section
- Paint all parts which are chipped or worn and require repainting.
- Store machine in a clean, dry place with the planting unit out of the sun.
- If the machine cannot be stored inside, cover with a waterproof tarpaulin and tie securely in place.
- Do not allow children to play on or around the machine

PART IDENTIFICATION 2967-042B-ST-FW

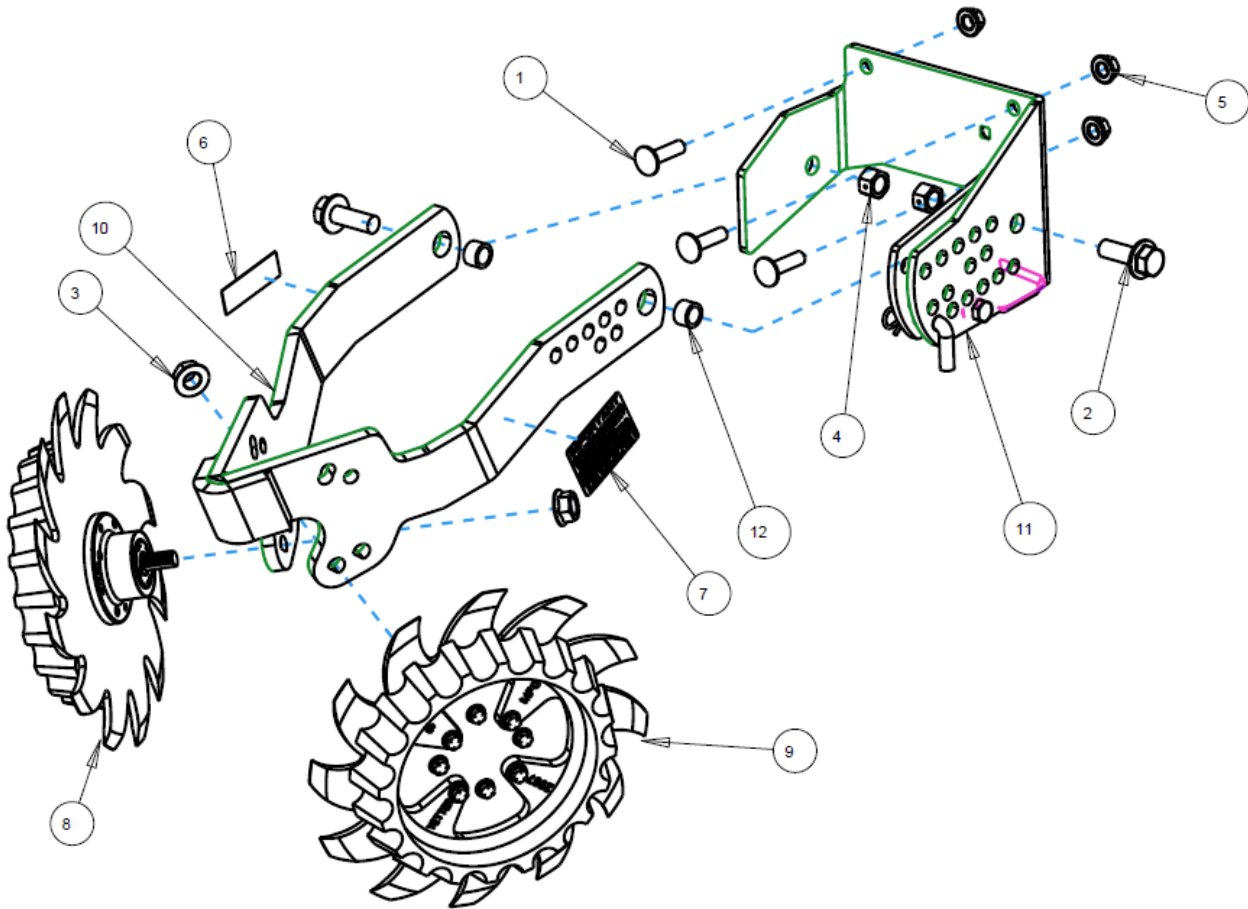

IS

ITEM	PART NO.	DESCRIPTION	QTY
1	2502-801	M12 X 45 CARRIAGE BOLT CLASS 8.8	3
2	2502-802	M16 X 45 FLANGE BOLT CLASS 10.9	2
3	2520-465	5/8-11 FLANGE NUT GRADE 8	2
4	2520-474	M16 LOCK NUT CLASS 10.9	2
5	2520-701	M12 FLANGE NUT CLASS 8.8	3
6	2565-179	YETTER DECAL	1
7	2565-502	FRAME HEIGHT DECAL	1
8	2966-116-ST-FW	RIGHT HAND SHARK TOOTH FLOATER WHEEL ASSEMBLY	1
9	2966-117-ST-FW	LEFT HAND SHARK TOOTH FLOATER WHEEL ASSEMBLY	1
10	2969-110	ARM ASSEMBLY	1
	2502-393	1/2-13 X 1-1/4 HHCS GRADE 5	4
	2520-364	1/2-13 JAM LOCK NUT	4
	2966-285	ARM	1
	2967-630	RIGHT HAND SCRAPER	1
	2967-631	LEFT HAND SCRAPER	1
	2565-179	YETTER DECAL	1
	2565-502	FRAME HEIGHT DECAL	1
11	2969-111	MOUNT BRACKET ASSEMBLY	1
	2502-800	M12 X 45 CLASS 8.8	1
	2520-700	M12 LOCKNUT	1
	2570-448	BOW TIE COTTER PIN	1
	2966-286	MOUNT BRACKET	1
	2966-373	ADJUSTMENT PLATE	1
	2967-613	PIN	1
12	6000-335	BUSHING	2

PART IDENTIFICATION 2969-110 ARM ASSEMBLY

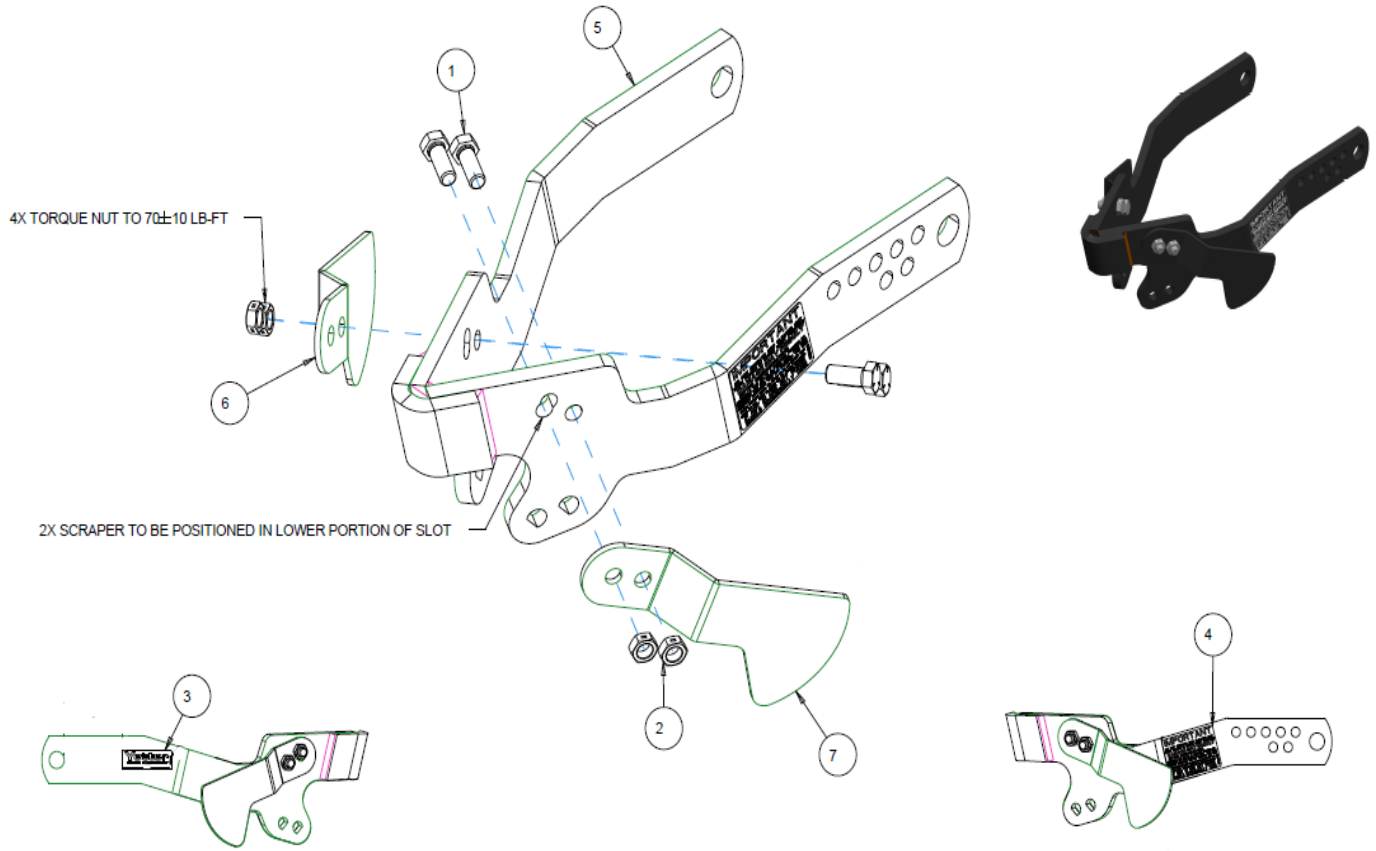

ITEM	PART NO.	DESCRIPTION	QTY
1	2502-293	1/2-13 X 1-1/4 HHCS GR5 ZP	4
2	2520-364	1/2-13 HEX LOCKNUT, JAM	4
3	2565-179	YETTER DECAL 1" X 3"	1
4	2565-502	LOCK-UP MESSAGE DECAL	1
5	2966-285	COMBO ARM W.A.	1
6	2967-630	SCRAPER, RH	1
7	2967-631	SCRAPER, LH	1

PART IDENTIFICATION
2969-111 MOUNT BRACKET ASSEMBLY

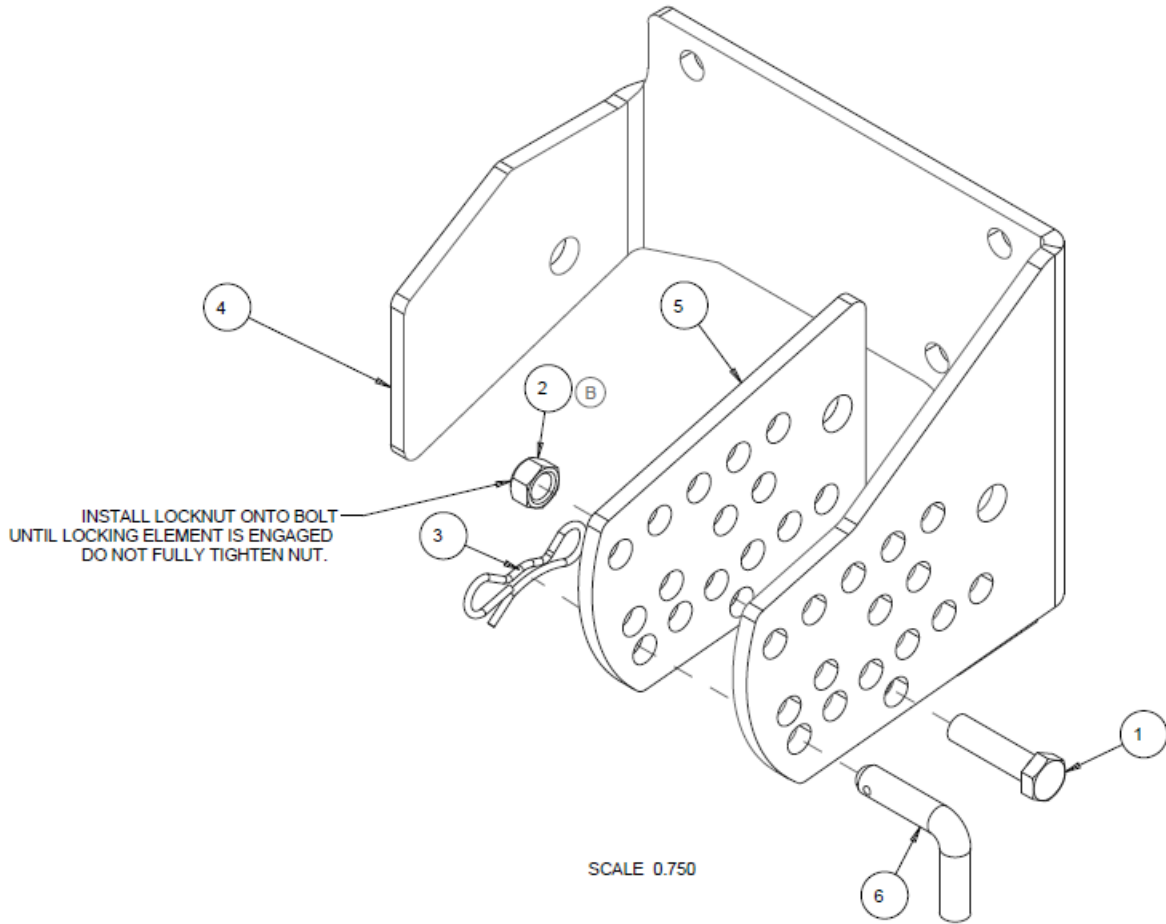

ITEM	PART NO.	DESCRIPTION	QTY
1	2502-800	12MM X 1.75 X 45 HHCS GR 8.8 ZP	1
2	2520-700	HEX LOCKNUT DEFLECTED THREAD-M12	1
3	2570-448	.120BOWTIE LCKING COTT ZP	1
4	2966-286	FACE PLATE W.A.	1
5	2966-373	PIN ADJUST PLATE	1
6	2967-613	TITAN PIN, JD, ZP	1

PARTS IDENTIFICATION

13" TAPER TOOTH SPOKE WHEEL

2966-117 (SHOWN)

2966-116

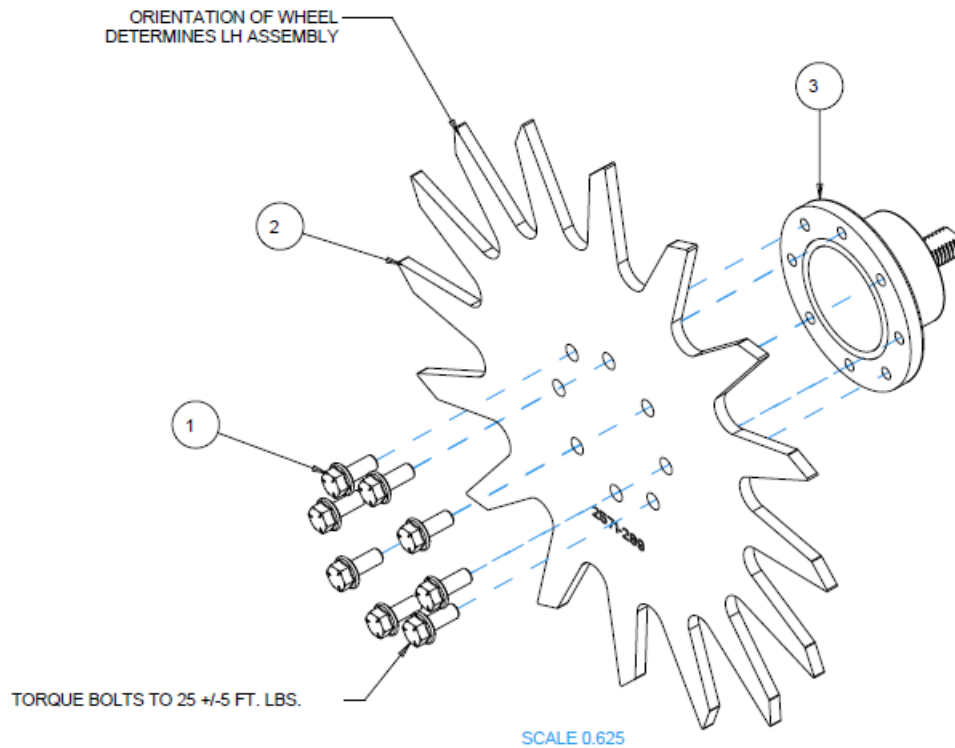

ITEM	PART NO.	DESCRIPTION	QTY
1	2502-220	5/16-18 X 3/4 HHFS GR5 ZP	8
2	2571-289	13" TAPER TOOTH SPOKE WHEEL, 8 BOLT	1
3	2965-502	HUB ASSEMBLY, 1.157 SPINDLE	1

PARTS IDENTIFICATION

13" BEVEL WHEEL

2966-117-BW

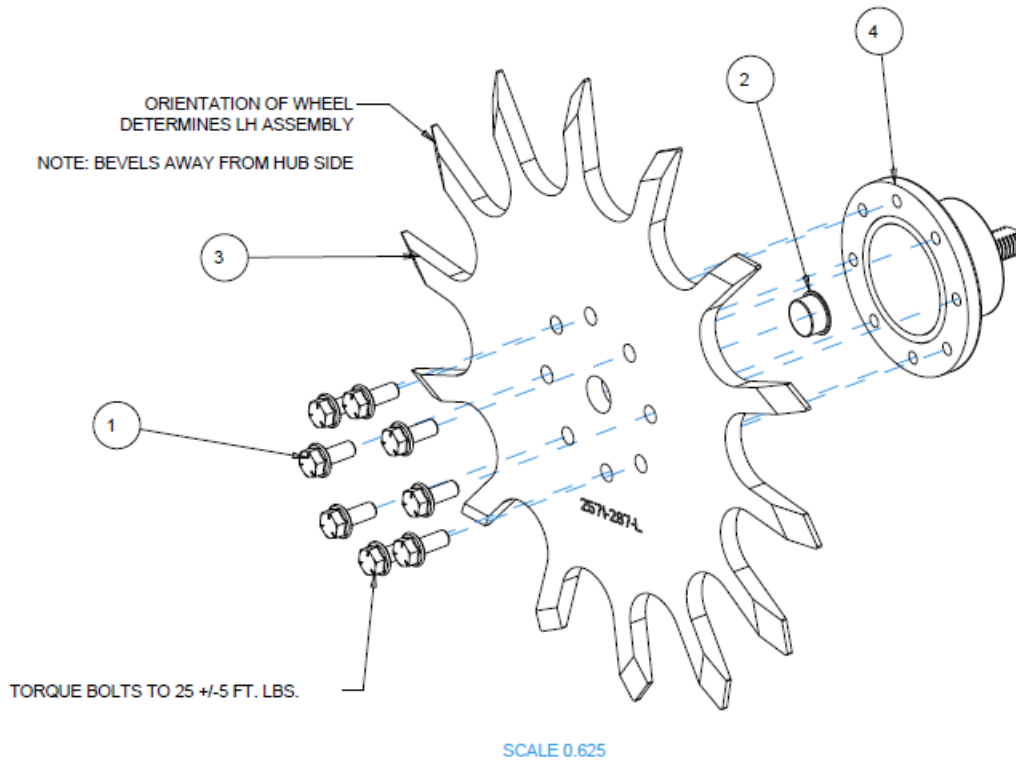

ITEM	PART NO.	DESCRIPTION	QTY
1	2502-220	5/16-18 X 3/4 HHFS GR5 ZP	8
2	2570-994	BEVEL WHEEL CENTER HOLE PLUG	1
3	2571-287-L	13" BEVEL WHEEL, 8 BOLT, LH	1
4	2965-502	HUB ASSEMBLY, 1.157 SPINDLE	1

PARTS IDENTIFICATION

13" BEVEL WHEEL

2966-116-BW

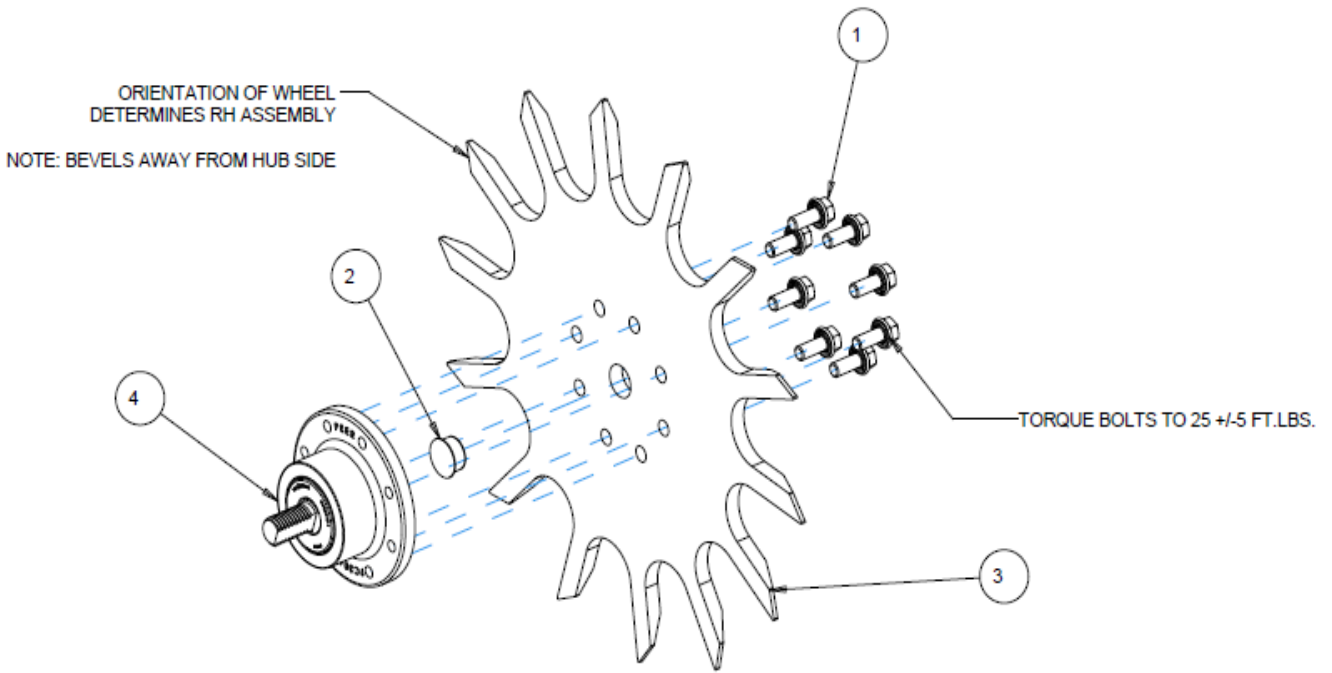

ITEM	PART NO.	DESCRIPTION	QTY
1	2502-220	5/16-18 X 3/4 HHFS GR5 ZP	8
2	2570-994	BEVEL WHEEL CENTER HOLE PLUG	1
3	2571-287-R	13" BEVEL WHEEL, 8 BOLT, RH	1
4	2965-502	HUB ASSEMBLY, 1.157 SPINDLE	1

PARTS IDENTIFICATION

13" SHARK TOOTH WHEEL

2966-117-ST-FW (SHOWN)

2966-117-ST-PFW (SHOWN)

2966-116-ST-FW

ITEM	PART NO	DESCRIPTION	QTY
1	2502-220	5/16-18 X ¾ HHFS GRADE 5	4
2	2502-221	5/16-18 X 1 HHFS GRADE 5	4
3	2571-286	SHARKTOOTH WHEEL 8 BOLT	1
4	2965-502	HUB ASSEMBLY 1.157 SPINDLE	1
5	2967-957	SHARKTOOTH TIMED FLOATER WHEEL	1

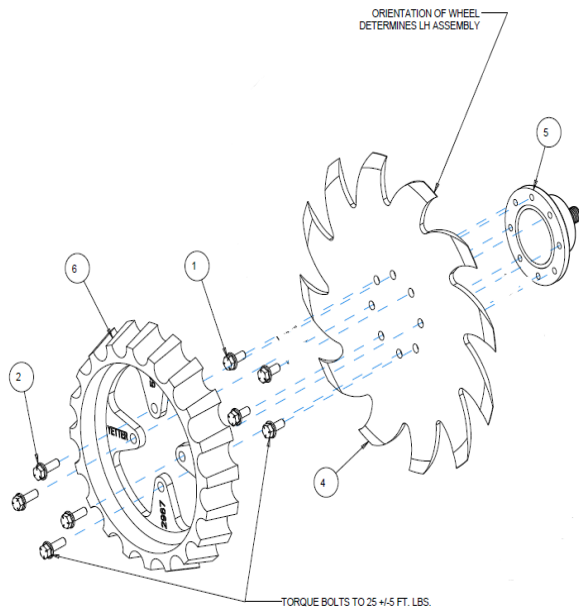

LINE UP ARROW ON FLOATER WITH
SLOT ON WHEEL TO INSURE
PROPER TIMING OF NOTCHES.

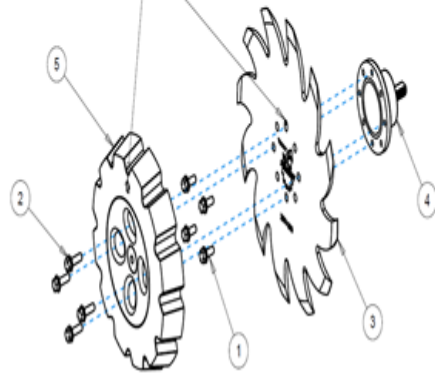

ITEM	PART NO.	DESCRIPTION	QTY
1	2502-220	5/16-18 X 3/4 HHFS GR5 ZP	4
2	2502-221	5/16-18 X 1 HHFS GR5 ZP	4
3	2515-562	13" WHEEL COVER, BLACK	2
4	2571-286	SHARKTOOTH WHEEL, 8 BOLT	1
5	2965-502	HUB ASSEMBLY, 1.157 SPINDLE	1
6	2967-560	FLOATER WHEEL	1

PARTS IDENTIFICATION

2966-116-STF (SHOWN) RIGHT HAND

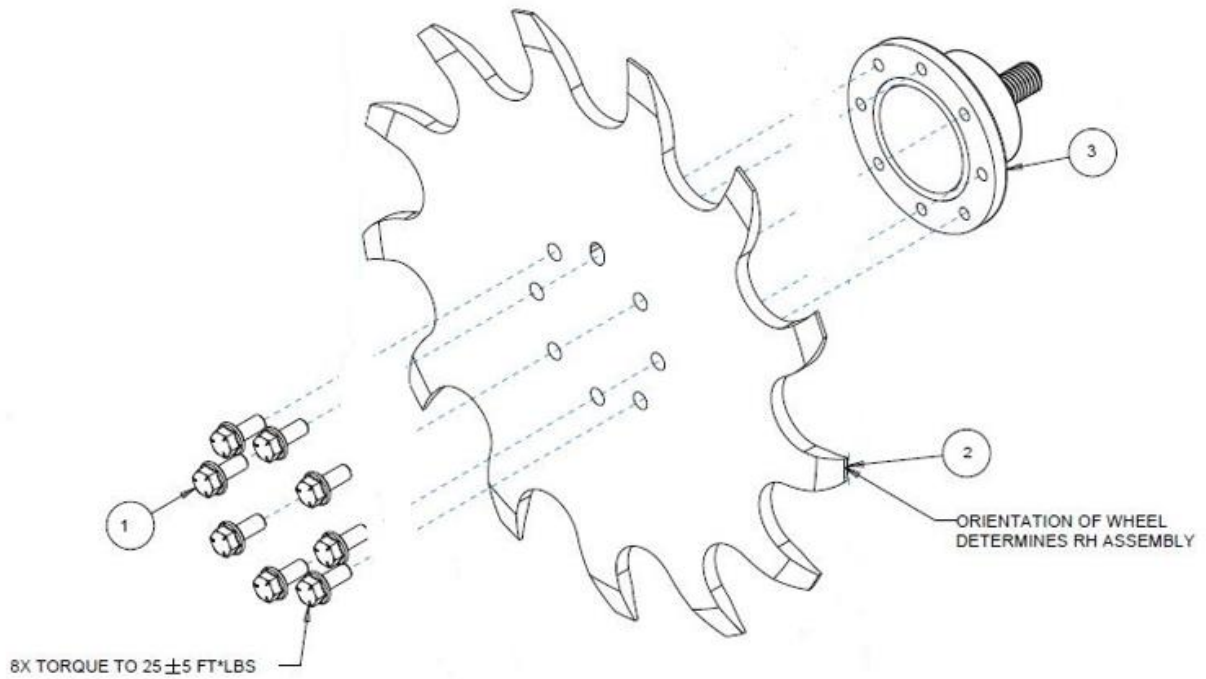

ITEM	QTY	PART NO.	DESCRIPTION
1	8	2502-220	5/16-18 X 3/4 HHFS BOLT GR5
2	1	2571-600	SHARKTOOTH FINGER WHEEL
3	1	2965-502	HUB ASSEMBLY 1.157" SPINDLE

PARTS IDENTIFICATION

2966-116-STF-FW (SHOWN) RIGHT HAND 2966-117-STF-FW LEFT HAND

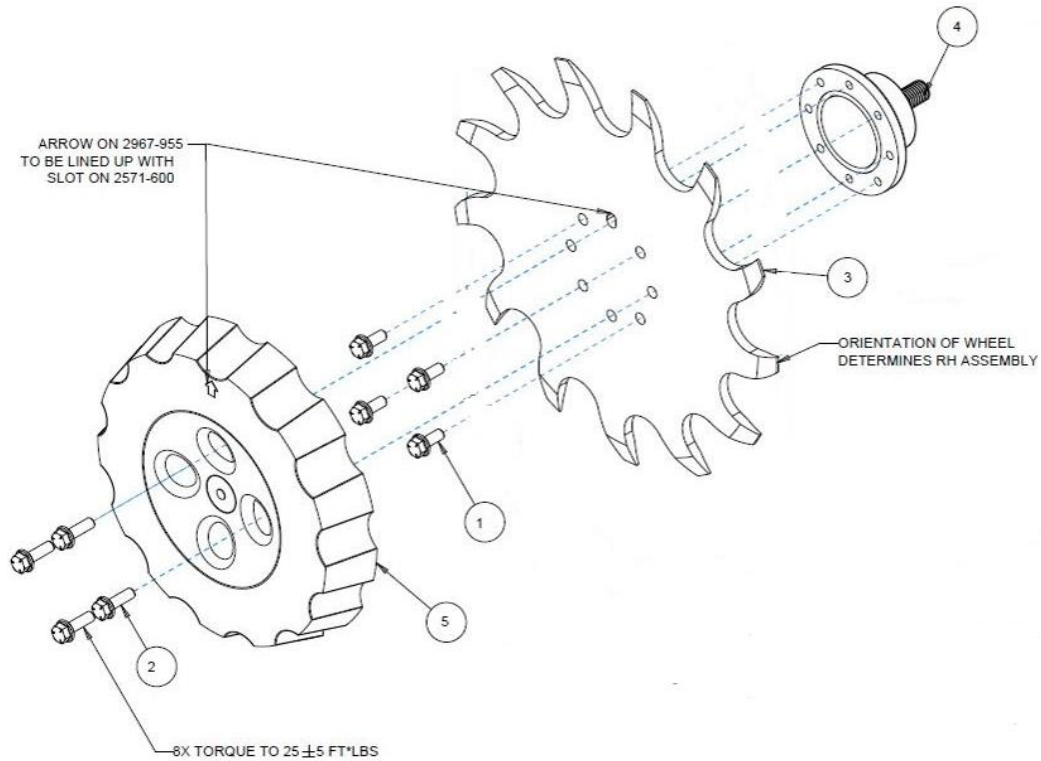

ITEM	QTY	PART NO.	DESCRIPTION
1	4	2502-220	5/16-18 X 3/4 HHFS BOLT GR5
2	4	2502-221	5/16-18 X 1 HHFS BOLT GR5
3	1	2571-600	SHARKTOOTH FINGER WHEEL
4	1	2965-502	HUB ASSEMBLY 1.157" SPINDLE
5	1	2967-955	STF TIMED FLOATER WHEEL

FIELD SERVICE KITS

- 2965-119 - SERVICE KIT FOR 2570-740-2.812 D-BOLT
 2965-120 - SERVICE KIT FOR 2570-742-3.812 D-BOLT
 2965-121 - SERVICE KIT FOR 2570-766-2.562 D-BOLT

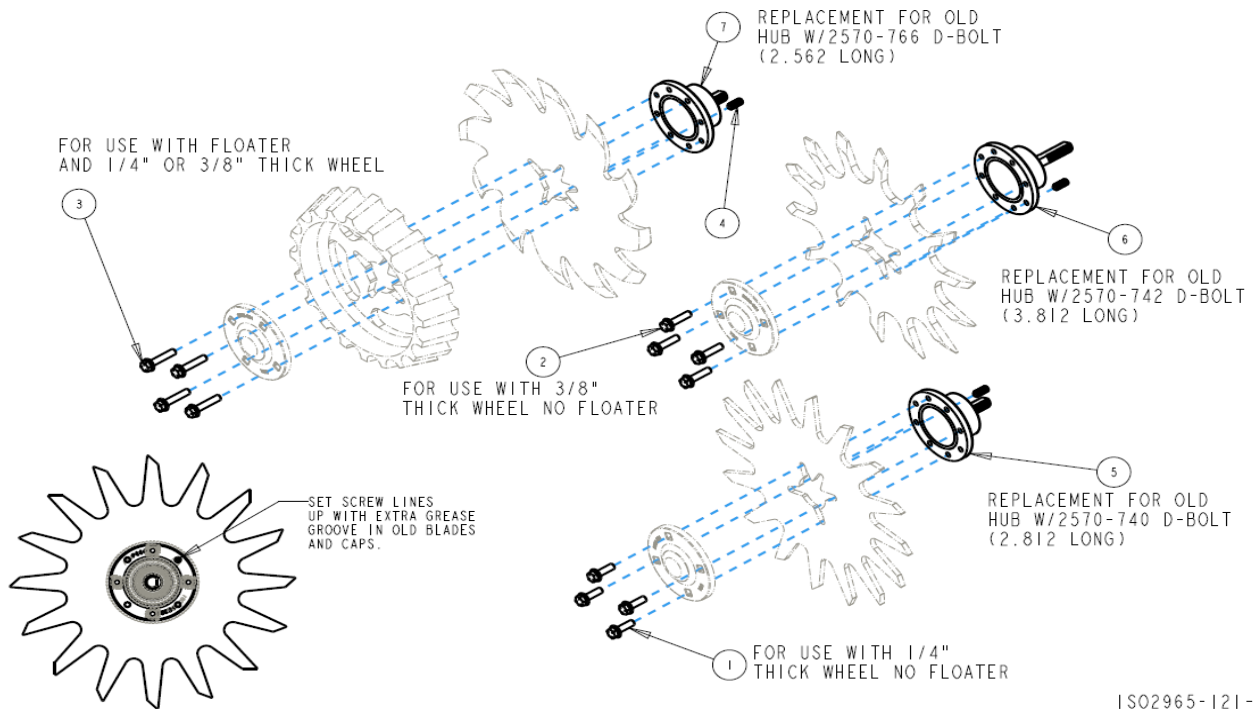

ISO2965-121-2

ITEM	PART NO	DESCRIPTION	QTY
1	2502-221	5/16-18 X 1 HHFS GRADE 5	4
2	2502-222	5/16-18 X 1-1/4 HHFS GRADE 5	4
3	2502-225	5/16-18 X 1-1/2 HHFS GRADE 5	4
4	2940-560	SET SCREW	1
5	2965-500	HUB ASSEMBLY 1.406 SPINDLE	1
6	2965-501	HUB ASSEMBLY 2.406 SPINDLE	1
7	2965-502	HUB ASSEMBLY 1.157 SPINDLE	1



ITEM	PART NO	DESCRIPTION	QTY
1	2505-207	5/16-18 X 1-1/4 CARRIAGE HEAD BOLT GRADE 5	4
2	2520-206	5/16-18 FLANGE LOCK NUT	4
3	2570-766	D-BOLT FLANGE HEAD 5/8-11 X 2.562 GRADE 8	1
4	2965-128	HUB/BEARING ASSEMBLY	1
	2550-069	SEAL	1
	2570-594	BEARING	1
	2570-715	INSERT	1
	2965-351	HUB	1
	2533-110	GREASE FITTING	1
5	2965-352	HUB CAP	1
6	2967-602	SHARK TOOTH WHEEL	1
7	2520-465	5/8-11 FLANGE LOCK NUT GRADE 8	1



A Tradition of Solutions since 1930

Yetter Farm Equipment Co

PO BOX 358 109 S. McDonough

Colchester, IL 62326-0358

Phone: 309-776-4111

Toll Free: 800-447-5777

Email: info@yetterco.com

For updated models and manuals visit the Yetter website:

www.yetterco.com

© Yetter Farm Equipment Co. All Rights Reserved

2565-955_REV_E • 08/2023