



**2960**

**UNIT MOUNTED  
CONSERVATION  
COULTER**

**FOR 800/900/950/955/1200  
CYCLO PLANTERS**

2565-635\_REV\_B • 12/2017

**YETTER MANUFACTURING CO.**

*FOUNDED 1930*

Colchester, IL 62326-0358

Toll free: 800/447-5777

309/776-3222 (Fax)

Website: [www.yetterco.com](http://www.yetterco.com)

E-mail: [info@yetterco.com](mailto:info@yetterco.com)

**YETTER**

## FOREWORD

You've just joined an exclusive but rapidly growing club.

For our part, we want to welcome you to the group and thank you for buying a Yetter product.

This is a unique and revolutionary new product.

We hope your new Yetter coultter will help you achieve both increased productivity and increased efficiency so that you may generate more profit. This operator's manual has been designed into four major sections.

Foreword, Safety Precautions, Installation and Operation.

Throughout the manual references may be made to left side and right side. These terms are used as viewed from the operator's seat facing the front of the tractor.



This **SAFETY ALERT SYMBOL** indicates important safety messages in the manual. When you see this symbol, be alert to the possibility of **PERSONAL INJURY** and carefully read the message that follows.

The word **NOTE** is used to convey information that is out of context with the manual text. It contains special information such as specifications, techniques, reference information of a supplementary nature.

The word **IMPORTANT** is used in the text when immediate damage will occur to the machine due to improper technique or operation. Important will apply to the same information as specified by note only of an immediate and urgent nature.

It is the responsibility of the user to read the operator's manual and comply with the safe and correct operating procedure and to lubricate and maintain the product according to the maintenance schedule in the operator's manual.

The user is responsible for inspecting his machine and for having parts repaired or replaced when continued use of the product would cause damage or excessive wear to the other parts.

It is the user's responsibility to deliver his machine to the Yetter dealer who sold him the product for service or replacement of defective parts, which are covered by the warranty policy.

**IMPORTANT:** When raising 3 pt. Toolbars watch tractor tire clearance. **EXAMPLE:** In most cases 3 pt. hitches require a cat. 2 or cat. 3 quick hitch coupler to offset toolbar away from tractor tires.

### YETTER MANUFACTURING CO.

309/776-4111

800/447-5777

309/776-3222 (FAX)

Website: [www.yetterco.com](http://www.yetterco.com)

Email: [info@yetterco.com](mailto:info@yetterco.com)

## WARRANTY POLICY

Yetter Manufacturing warrants all products manufactured and sold by it against defects in material. This warranty being expressly limited to replacement at the factory of such parts or products as will appear to be defective after inspection. This warranty does not obligate the Company to bear cost of labor in replacement of parts. It is the policy of the company to make improvements without incurring obligations to add them to any unit already sold. No warranty is made or authorized to be made, other than herein set forth. This warranty is in effect for one year after purchase.

**Yetter Manufacturing warrants its own products only and cannot be responsible for damage to equipment on which mounted.**

## **SAFETY**

**A brief description of signal words that may be used in this manual:**

**CAUTION:** Used as a general reminder of good safety practices or to direct attention to unsafe practices.

**WARNING:** Denotes a specific potential hazard.

**DANGER:** Denotes the most serious specific potential hazard.

### **SAFETY PRECAUTIONS**

You can make your farm a safer place to live and work if you observe the safety precautions given. Study these precautions carefully and insist that those working with you and for you follow them.

Finally, remember this: an accident is usually caused by someone's carelessness, neglect or oversight.



#### **WARNING**

Never clean, lubricate or adjust a machine that is in motion.

Always lower or block the implement before performing service.

If the machine must be serviced in the raised position, jack or block it up to prevent it from accidentally falling and injuring someone.

Do not allow riders on the tractor or implement.

Use speeds and caution dictated by the terrain being traversed. Do not operate on any slope steep enough to cause tipping or loss of control.

Be sure all personnel are clear of the immediate area before operating.

Read and understand the operator's manual and require all other persons who will operate the equipment to do the same.

Be familiar with all tractor and implement controls and be prepared to stop engine and implements quickly in an emergency.



#### **CAUTION**

Consult your implement and tractor operator's manual for correct and safe operating practices.

Beware of towed implement width and allow safe clearance.

**FAILURE TO HEED MAY RESULT IN PERSONAL INJURY OR DEATH.**

# TABLE OF CONTENTS



Cover Page.....	pg. 1
Foreword.....	pg. 2
Safety Symbols and meanings.....	pg. 2-3
Table of Contents.....	pg. 4
Torque Specifications.....	pg. 4
Assembly Instructions.....	pg. 5
Operation.....	pg. 6
Maintenance.....	pg. 6,9
Parts Identification.....	pg. 7-8
Trouble Shooting.....	pg. 10-11

## BOLT TORQUE

READ THESE INSTRUCTIONS FIRST:

1. Improperly tightened bolts will result in damage, breakage, expense, and down time.
2. Always replace bolts with the specified grade and type.
3. Torque properly before first use of the machine and every 2-4 hours of use until you are sure bolts are staying tight.
4. The chart below is a guide for proper torque. Use is unless a specified torque is called out elsewhere in the manual.
5. Torque is the force you apply to the wrench handle or the cheater bar, times the length of the handle or bar used.
6. Use a torque wrench whenever possible.

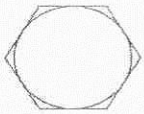
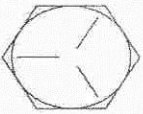
The following table shows torque in foot pounds.

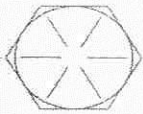
BOLT DIA. AND THREADS PER INCH	 GRADE 2	 OR  GRADE 5 A-325	 GRADE 8
1/4	6	10	14
5/16	12	20	30
3/8 - 16	25	35	50
7/16 - 14	35	55	80
1/2 - 13	55	85	125
9/16 - 12	75	125	175
5/8 - 11	105	170	235
3/4 - 10	185	305	425
7/8 - 9	170	445	690
1-8	260	670	1030
1 1/8 - 7	365	900	1460
1 1/4 - 7	515	1275	2060
1 3/8 - 6	675	1675	2700
1 1/2 - 6	900	2150	3500
1 3/4 - 5	1410	3500	5600

## HEAVY DUTY COULTER INSTALLATION

**NOTE:** Mounting hardware included in 2960-145 bolt bag.

1. Attach the unit coultter assembly to the planter unit with the two  $\frac{1}{2}$ -13 x 3- $\frac{3}{4}$ " bolts and locknuts. As supplied, the disc is set in the shallowest position, the blade will run at approximately the same depth as the opener blades. **Ensure that in operation the planter frame is at the correct height (20"-22") and level the tool bar.**
2. To adjust the depth of the coultter blade relative to the opener, remove the  $\frac{5}{8}$ " bolt through the hub assembly, reposition and replace bolt. Tighten bolt securely. If assembly is removed note the position of various spacers.
3. Assemble 2960-223 unit stops to upper parallel arms with  $\frac{3}{8}$ -16 x 1- $\frac{1}{4}$ " bolts, flat washers and locknuts as shown in illustration on following page.

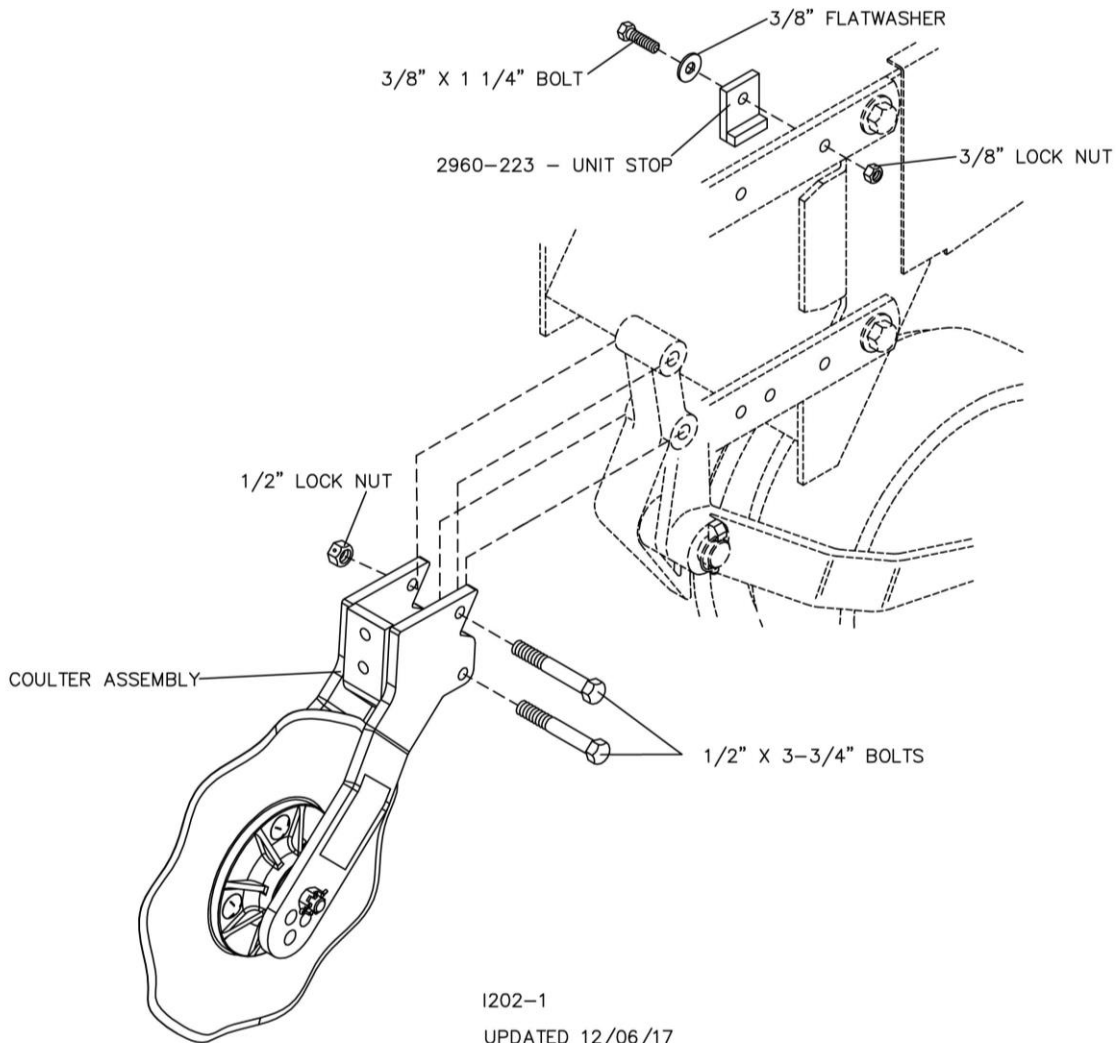

## OPERATION

1. Set/mount coulter blades to run perpendicular to the soil. Operation depth and blade wear can be affected if the coulter is mounted crooked or if the toolbar is not level side to side.
2. After a few hours of use, check all bolts for tightness and proper torque.
3. After a day of use (10-12 hours) check coulter hubs for loose bearings. There should be no endplay in the hub bearings allowing the blade to wobble. If necessary, remove cotter pin and adjust the slotted nut to remove wobble, recommended torque of 150 in. lbs. and re-insert cotter pin. If the wobble or looseness cannot be corrected, the bearings, cups and seals will need to be replaced.

**DO NOT USE WORN OR DAMAGED PARTS.**

## MAINTENANCE

LUBRICATION: USE #2 MULTI-PURPOSE LITHIUM GREASE

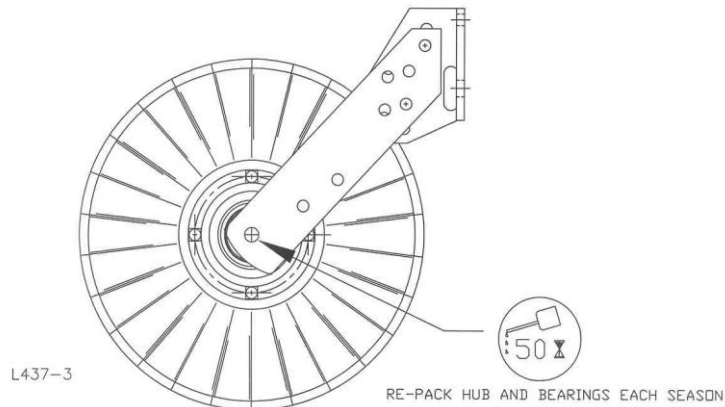

To ensure longevity and reliability of the 2960-020 coulter, the recommended lubrication schedule should be followed using multi-purpose grease at hourly intervals as indicated.

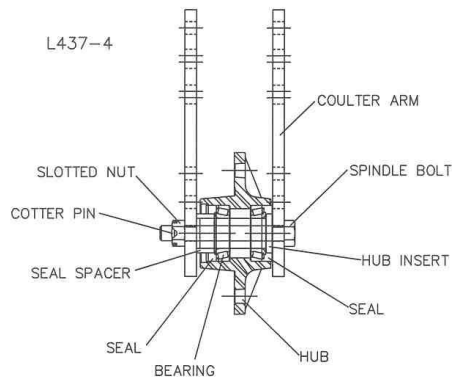

### BEARING ADJUSTMENT:

1. Raise the toolbar until the blade is clear of the ground. Place a safety stand under the toolbar. Remove the cotter pin, slotted nut, washer and bolt from the hub assembly. Remove the blade from the hub assembly.
2. Remove bearing cones and seals from hub.
3. Wash the old grease from the hub, bearing cups, spindle spacers, seals and bearing cones. Inspect the condition of the bearing cups, cones and seals. Replace if necessary.
4. Apply #2 multi-purpose lithium grease on each bearing. Make sure the space around each roller is filled. Lubricate the bearing cups.
5. Position the bearing in the cup and install the seal. Lubricate the seal lips and proceed with re-assembly of the removed parts including the blade. Blade bolt torque is 90 to 96 ft. lbs.
6. Tighten the slotted nut to 150 in. lbs. or until a definite drag is felt when the blade is turned by hand. Tighten the nut one slot position to line up the cotter pin hole with a slot. Secure the nut with a new cotter pin.

# PARTS IDENTIFICATION

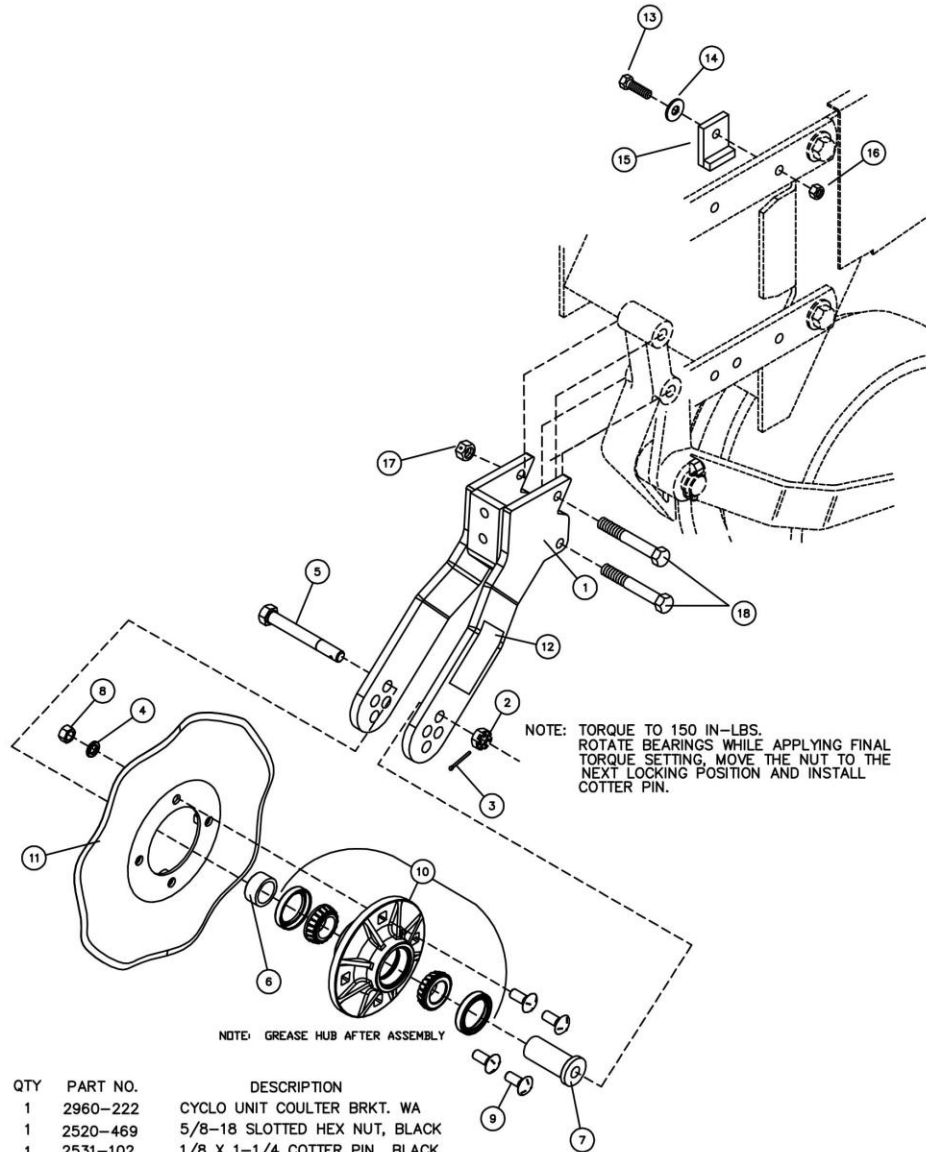

UPDATED 12/06/17  
I202-4

DET	QTY	PART NO.	DESCRIPTION
1	1	2960-222	CYCLO UNIT COULTER BRKT. WA
2	1	2520-469	5/8-18 SLOTTED HEX NUT, BLACK
3	1	2531-102	1/8 X 1-1/4 COTTER PIN BLACK
4	4	2525-352	1/2 MED LOCKWASHER ZP
5	1	2960-392	SPINDLE BOLT, 5/8 X 5 GR 5 ZYD
6	1	2960-394	SEAL SPACER
7	1	2960-393	HUB INSERT
8	4	2520-352	1/2-13 HEX NUT ZP
9	4	2505-337	1/2-13 X 1 1/4 CARBLT G5ZP
10	1	2984-107	HUB SUB ASSEMBLY
	2	2550-027	CONE, LM67048
	2	2550-066	TRIPLE LIP SEAL, NTI #1812-4
	1	2900-105	HUB PRESSED ASSEMBLY
	1	2533-110	1/4-28 ZERK STRAIGHT SELF-TAP
	2	2550-029	CUP, LM67010
11	1	2571-164	.157 X 14.56", 8 FLUTE BLADE
	1	2571-166	.157 X 14.56", 25 FLUTE BLADE
12	1	2565-162	YETTER DECAL, 1-1/2 X 4-1/2
13	2	2502-244	3/8-16 X 1-1/4 HHCS GR 5 ZP
14	2	2526-253	3/8 SAE FLATWASHER ZP
15	2	2960-223	CYCLO STOP CASTING
16	2	2520-255	3/8-16 LOCK HEX NUT, GR A, ZP
17	2	2520-357	1/2-13 LOCK HEX NUT, GR A, ZP
18	2	2502-316	1/2-13 X 3-1/2 HHCS GR5 ZP

**PRODUCTION DATE 12/02-PRESENT**

# PARTS IDENTIFICATION

2960-020 – UNIT MOUNTED COULTER, IH 800/900  
 2960-020-MW – UNIT MOUNTED COULTER, IH 800/900, MW

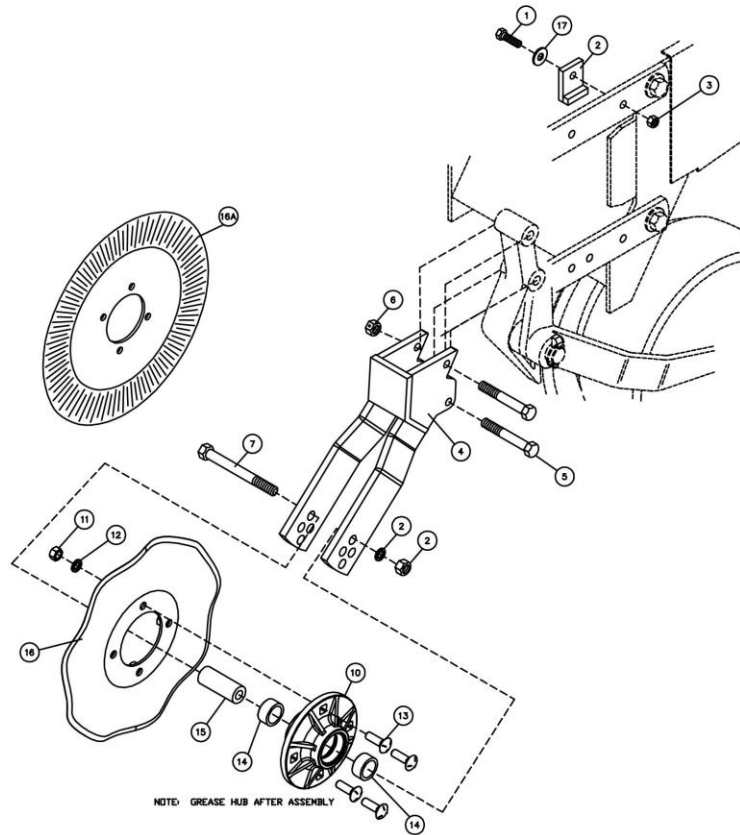

I202-7

DET	QTY	PART NO.	DESCRIPTION
1	2	2502-244	3/8-16 X 1-1/4 HHCS GR 5 ZYD
2	2	2960-223	CYCLU UNIT STOP, WA
3	2	2520-255	3/8-16 LOCK HEX NUT ZYD
4	1	2960-222	CYCLU UNIT COULTER BRKT, WA
5	2	2502-316	1/2-13 X 3-1/2 HHCS GR 5 ZYD
6	2	2520-357	1/2-13 HEX LOCK NUT ZYD
7	1	2502-327	5/8-11 X HHCS GR 5 ZYD
8	1	2525-451	5/8 MED LOCKWASHER ZYD
9	1	2520-452	5/8-11 HEX NUT ZYD
10	1	2960-375	MACHINED HUB (HUB ASSEMBLY)
	1	2550-055	BRG SET, TIMKEN #LM67048-902A1 (SERVICE PART)
	2	2550-066	TRIPLE LIP SEAL, NTI #1812-4 (SERVICE PART)
11	4	2520-352	1/2-13 HEX NUT ZYD
12	4	2525-352	1/2 MED LOCKWASHER ZYD
13	4	2505-339	1/2-13 X 1-1/2 CAR BOLT GR 5 ZYD
14	2	2960-371	SPINDLE SPACER, 59/64
15	1	2960-370	SPINDLE SPACER, 3-13/64
16	1	2571-164	.157 X 14.56 8 FLUTE BLADE
16A	1	2571-166	.157 X 14.56 25 FLUTE BLADE (OPTIONAL)
17	2	2526-253	3/8 SAE FLATWASHER ZP

UPDATED 12/7/17

**PRODUCTION DATES 2/92 – 11/02**



# SERVICE AND MAINTENANCE

## FOR COULTERS PRODUCED 2/92 – 11/02

The bearings in the hub of this coulters are a 'MATCHED SET' and therefore when repairs are required it will be necessary to replace all six components of the bearing set. **DO NOT REPLACE INDIVIDUAL COMPONENTS OF THE BEARING.** All of the components of the bearing are matched by the bearing company to provide the correct range of free-play in the assembled unit.

The bearings may be cleaned and repacked with multi-purpose grease like any other taper roller bearing setup so long as all the parts from each hub remain and return to the same hub.

**IMPORTANT**  
**USE ONLY**  
**'MATCHED SET'**  
**TIMPKEN Bearing**  
**#LM67048-902A1**

When installing a bearing set, the new snap rings supplied with the new bearing must be used.

**LUBRICATION:** To ensure longevity and reliability of the coulters, the lubrication schedule should be followed using multi-purpose grease at 50 hour intervals and re-pack each season.

### TO UPDATE COULTERS PRODUCED 2/92 – 11/02 THE FOLLOWING KIT IS NEEDED

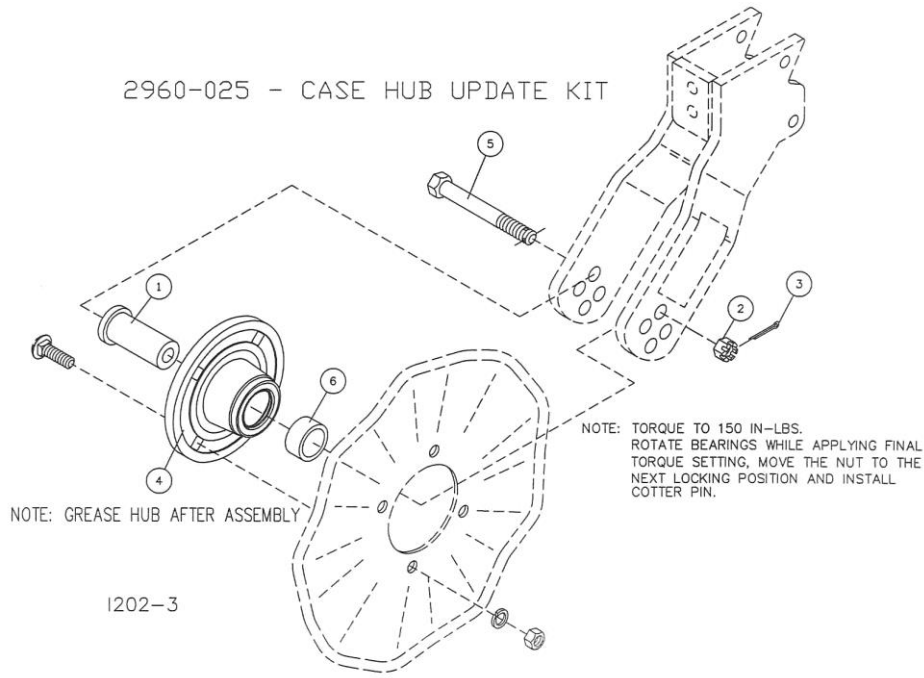

DET	QTY	PART NO.	DESCRIPTION
1	1	2960-393	HUB INSERT
2	1	2520-469	5/8-18 SLOTTED HEX NUT, BLACK
3	1	2531-102	1/8 X 1-1/4 COTTER PIN BLACK
4	1	2984-107	HUB SUB ASSEMBLY, MAVERICK
5	1	2960-392	SPINDLE BOLT, 5/8 X 5 GR 5 ZYD
6	1	2960-394	SEAL SPACER

## TROUBLESHOOTING

Problem	Cause	Solution
Cannot adjust coulter depth shallow enough.	Planter frame not set correctly.	Ensure that in operation the planter frame is at correct height (20"-22") and level the toolbar, refer to opposite page.
	Coulter blade is too big.	Blade must be 14 5/8" diameter.
	Planter opener blades worn.	Replace planter opener blades.
Cannot adjust coulter deep enough.	Coulter blade worn too small.	Replace coulter blade.
Coulter will not penetrate.	Lack of spring tension.	Increase spring tension.
Coulter penetrates too much.	Excessive spring down pressure.	Reduce spring tension.
Seed placement is too deep.	Coulter blade set too deep relative to openers.	Shallow up coulter depth.
Optional wavy blade disturbs too much soil.	Planter frame not level front to back.	Raise the planter drawbar to level planter frame.
	Soil too damp or loose.	Reduce ground speed.
		Install a less aggressive blade.
No spring tension.	Planter frame not set correctly.	Check planter frame settings, see above.
	Broken springs.	Replace broken or damaged parts.

# PLANTER HEIGHT ADJUSTMENT

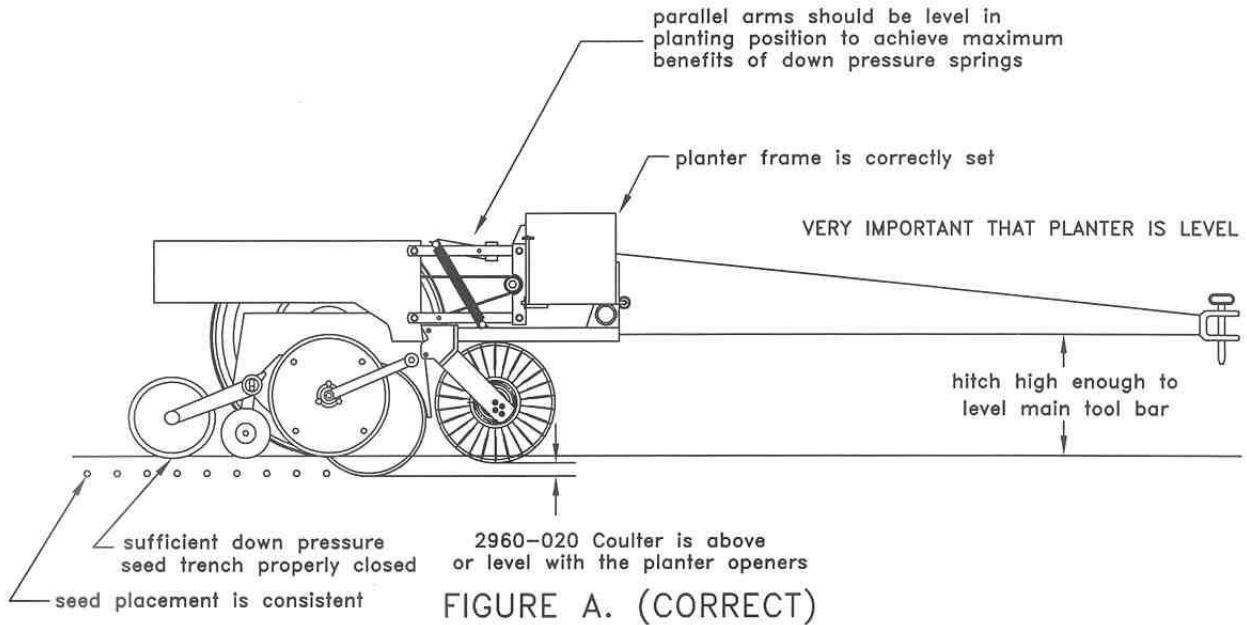

S284-9

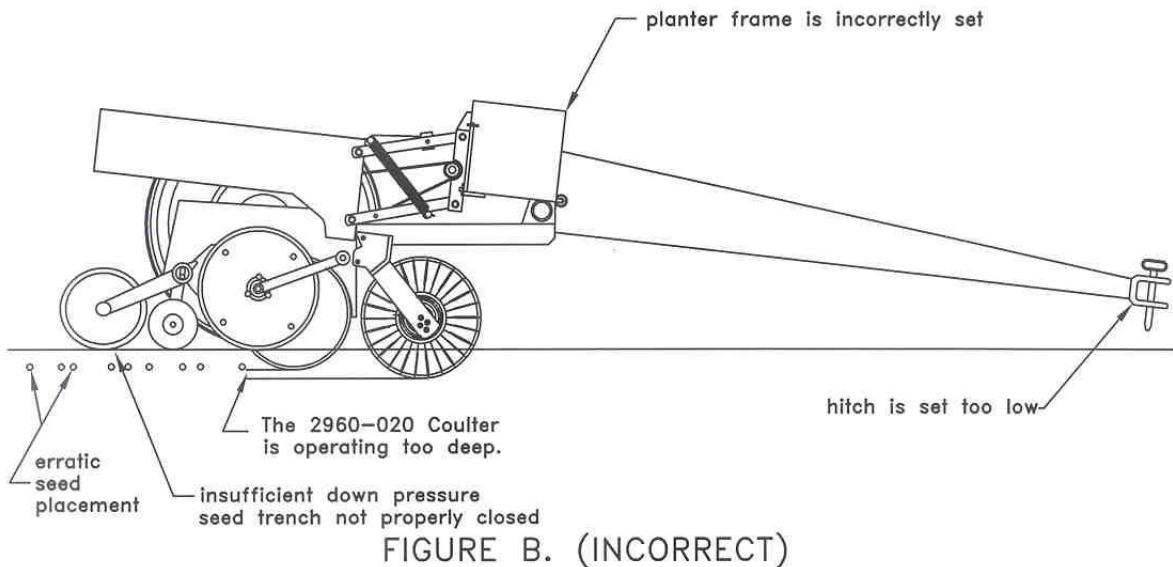

Figure A. – The planter hitch and frame are both 20” off the ground. To ensure this, visually check to see that the planter boxes are level and that the planter unit parallel arms are also parallel with the ground. When using planter attachments located in front of the planter unit, this setting is very important.

Figure B. – The planter hitch is set too low while the planter frame remains at 20” off the ground! Notice from the illustration that the unit mounted coulters is running deeper in the ground than the planter unit. This condition can result in the formation of an air pocket below the seed bed which will in turn dramatically decrease seed growth.

NOTE: Both illustrations are strictly for reference only. They are intended to show that proper adjustment of the hitch height is critical. Consult your planter operator’s manual for the proper height adjustment of the hitch.

# Our name —Is getting known—

**J**ust a few years ago, Yetter products were sold primarily to the Midwest only. Then we embarked on a program of expansion and moved into the East, the South, the West and now north into Canada. We're even getting orders from as far away as Australia and Africa.

**S**o, when you buy Yetter products . . .you're buying a name that's recognized. A name that's known and respected. A name that's become a part of American agriculture and has become synonymous with quality and satisfaction in the field of conservation tillage.

Thank you.

**YETTER MANUFACTURING CO.**

COLCHESTER, IL 62326-0358 ☎ 309/776-4111

TOLL FREE 800/447-5777

FAX 309/776-3222

WEBSITE: [WWW.YETTERCO.COM](http://WWW.YETTERCO.COM)

E-MAIL: [INFO@YETTERCO.COM](mailto:INFO@YETTERCO.COM)