



**2940 AIR ADJUST RESIDUE MANAGER**  
**2940-050A YETTER ELECTRIC COMPRESSOR**  
OPERATOR'S MANUAL  
2565-773\_REV\_G • 07/2021



\*Patented

**YETTER MANUFACTURING CO.**  
*FOUNDED 1930*

Colchester, IL 62326-0358  
Toll free: 800/447-5777  
309/776-3222 (Fax)  
Website: [www.yetterco.com](http://www.yetterco.com)  
E-mail: [info@yetterco.com](mailto:info@yetterco.com)

**GERMINATE UNIFORMITY™**



# TABLE OF CONTENTS

Bolt Torque.....	2
Safety.....	4
2940 Components, Kits, Accessories, and Ordering Part Numbers.....	5-9
Introduction & System Requirements.....	10
System Information.....	11-14
Installation Instructions.....	15-37
<b>Installation Guide.....</b>	<b>15</b>
<b>Residue Manager/RM Coulter Combo.....</b>	<b>16-19</b>
<b>Cab Controller.....</b>	<b>20</b>
<b>Compressor .....</b>	<b>21</b>
<b>Control Box .....</b>	<b>22</b>
<b>Compressor &amp; Control Box Cable/Harnesses.....</b>	<b>23-24</b>
<b>Dump Valve Assembly.....</b>	<b>24</b>
<b>Airline Routing.....</b>	<b>25</b>
<b>Airline &amp; Dump Valve Diagrams.....</b>	<b>26-37</b>
Operation.....	38-45
Maintenance.....	46
Parts Identification.....	47-64
Troubleshooting.....	65

## BOLT TORQUE





### Mounting bolts and hardware

All hardware used on the 2940 Air Adjust is Grade 5 unless otherwise noted. Grade 5 cap screws are marked with three radial lines on the head. If hardware must be replaced, be sure to replace it with hardware of equal size, strength and thread type. Refer to the torque values chart when tightening hardware.

 **Important:** Over tightening hardware can cause as much damage as when under tightening. Tightening hardware beyond the recommended range can reduce its shock load capacity.

The chart below is a guide for proper torque. Use it unless a specified torque is called out elsewhere in the manual. Torque is the force you apply to the wrench handle or the cheater bar, times the length of the handle or bar. Use a torque wrench whenever possible.

The following table shows torque in ft. lbs. for coarse thread hardware.

BOLT DIA. AND THREADS PER INCH	 GRADE 2	 OR  GRADE 5 A-325	 GRADE 8
3/8-10	25	35	50
7/16-14	35	55	80
1/2-13	55	85	125
9/16-12	75	125	175
5/8-11	105	170	235
3/4-10	180	305	425
7/8-9	170	445	630
1-8	260	670	1030
1 1/8-7	365	900	1480
1 1/4-7	515	1275	2080
1 3/8-6	675	1875	2700
1 1/2-6	900	2150	3500
1 3/4-5	1410	3500	5800

# FOREWORD

You've just joined an exclusive but rapidly growing club.

For our part, we want to welcome you to the group and thank you for buying a Yetter product.

We hope your new Yetter products will help you achieve both goals-increase your productivity and increase your efficiency so that you may generate more profit.

This operator's manual has been designed into four major sections: Foreword, Safety Precautions, Installation Instructions and Parts Breakdown.



This **SAFETY ALERT SYMBOL** indicates important safety messages in the manual. When you see this symbol, be alert to the possibility of **PERSONAL INJURY** and carefully read the message that follows.

The word **NOTE** is used to convey information that is out of context with the manual text. It contains special information such as specifications, techniques and reference information of a supplementary nature.

The word **IMPORTANT** is used in the text when immediate damage will occur to the machine

due to improper technique or operation. Important will apply to the same information as specified by note only of an immediate and urgent nature.

It is the responsibility of the user to read the operator's manual and comply with the safe and correct operating procedure and to lubricate and maintain the product according to the maintenance schedule in the operator's manual.

The user is responsible for inspecting his machine and for having parts repaired or replaced when continued use of the product would cause damage or excessive wear to the other parts.

It is the user's responsibility to deliver his machine to the Yetter dealer who sold him the product for service or replacement of defective parts, which are covered by the warranty policy.

If you are unable to understand or follow the instructions provided in this publication, consult your local Yetter dealer or contact:

## YETTER MANUFACTURING CO.

309/776-4111

800/447-5777

309/776-3222 (FAX)

Website: [www.yetterco.com](http://www.yetterco.com)

E-mail: [info@yetterco.co](mailto:info@yetterco.co)

# WARRANTY

Yetter Manufacturing warrants all products manufactured and sold by it against defects in material. This warranty being expressly limited to replacement at the factory of such parts or products as shall appear to be defective after inspection. This warranty does not obligate the Company to bear cost of labor in replacement of parts. It is the policy of the Company to make improvements without incurring obligations to add them to any unit already sold. No warranty is made or authorized to be made, other than herein set forth. This warranty is in effect for one year after purchase.

DEALER: \_\_\_\_\_

**Yetter Manufacturing warrants its own products only and cannot be responsible for damages to equipment on which mount**

# SAFETY

**A brief description of signal words that may be used in this manual:**

**CAUTION:** Used as a general reminder of good safety practices or to direct attention to unsafe practices.

**WARNING:** Denotes a specific potential hazard.

**DANGER:** Denotes the most serious specific potential hazard.

## SAFETY PRECAUTIONS

You can make your farm a safer place to live and work if you observe the safety precautions given. Study these precautions carefully and insist that those working with you and for you follow them.

Finally, remember this: an accident is usually caused by someone's carelessness, neglect or oversight.



### WARNING

Never clean, lubricate or adjust a machine that is in motion. Always lower or block the implement before performing service.

If the machine must be serviced in the raised position, jack or block it up to prevent it from accidentally falling and injuring someone.

Do not allow riders on the tractor or implement.

Use speeds and caution dictated by the terrain being traversed. Do not operate on any slope steep enough to cause tipping or loss of control.

Be sure all personnel are clear of the immediate area before operating.

Read and understand the operator's manual and require all other persons who will operate the equipment to do the same.

Be familiar with all tractor and implement controls and be prepared to stop engine and implements quickly in an emergency.



### CAUTION

Consult your implement and tractor operator's manual for correct and safe operating practices.

Beware of towed implement width and allow safe clearance.



**FAILURE TO HEED MAY RESULT IN PERSONAL INJURY OR DEATH.**

# Components, Kits, Accessories, & Ordering Numbers

## Residue Manager Kits

2940-001B	Pneumatic Residue Manager (RM) Assembly with choice of wheel kit (JD 1700 & 7200, White 9000)
2940-002B	Pneumatic Narrow RM Assembly with choice of wheel kit (JD 1700 & 7200, White 9000, AME)
2940-003B	Pneumatic RM Assembly with choice of wheel kit (CNH 800 – 1200)
2940-004B	Pneumatic Narrow RM Assembly with choice of wheel kit (CNH 800 – 1200)
2940-005B	Pneumatic RM Assembly with choice of wheel kit (JD 7000, White 6000 & 8000, Kinze 2000, 3000, & 4900)
2940-006B	Pneumatic Narrow RM Assembly with choice of wheel kit (JD 7000, White 6000 & 8000, Kinze 2000, 3000, & 4900)
2940-007B	Pneumatic RM/Coulter Combo with choice of wheel kit & coulter blade (JD 7000, White 6000 & 8000, Kinze)
2940-010B	Pneumatic RM/Coulter Combo with choice of wheel kit & coulter blade (JD 1700 & 7200, White 9000)
2940-018	Coulter Less RM Less Blade for JD 7000, Agco 6000 & 8000, Kinze
2940-019	Coulter Less RM Less Blade for JD 1700, 7200, Agco 9000

## Compressor Kit

2940-050A Electric Pneumatic Compressor

## Control Kits

2940-053 Pneumatic Control Box w/ Yetter Monitor  
 2940-053-LM Pneumatic Control Box Less Yetter Monitor









## Air Lines and Wiring Kits

2940-065	6 & 8 Row Wiring/Tubing Kit
2940-067	12 & 16 Row Wiring/Tubing Kit
2940-072	Split Row/Interplant Kit
2940-087	ISOBUS Kit















## Compressor Mounting Kits

2940-085	Bracket Two Point Hitch Kit	2940-090	8 X 12 Mount Kit
2940-086	Bracket Draft Tube Kit or Universal Kit	2940-091	8 X 16 Mount Kit

## Part Numbers and Descriptions

2940-049	Air Adjust Mount Ext. Kit (For JD HD scrapers)→	
2940-100	Data Panel/Cab Controller-----→	
2940-101A	Electric Pneumatic Compressor -----→	
2940-103	Pneumatic Control Box -----→	
2940-112	VDM 12 Volt Controller-----→	
2940-113	RAM Cab Controller Mount Kit-----→	
2940-119	Electric Compressor Rebuild Kit	
2940-126A	Pneumatic Combo Sub-Assembly (2940-010)	
2940-130A	Pneumatic Combo Sub-Assembly(2940-007A)	
2940-136	Dump Valve Kit-----→	
2940-139	Pressure On Valve-----→	
2940-147	Package of 10 Tees-----→	

# Components, Kits, Accessories, & Ordering Numbers

2940-148	Package of Zip Ties (100) ----->	
2940-149	Manual Kit & Cab Controller Mount Bolt Bag ->	
2940-150	Main Power Cable with 80A Breaker----->	
2940-151	10 ft. Main Power Cable Extension ----->	
2940-152	Hitch to Cab Controller CAN Cable----->	
2940-153	Cab Controller IGN/GRD Supply Harness----->	
2940-154	30 ft. Dump Valve Cable Black ----->	
2940-155	30 ft. Dump Valve Cable White----->	
2940-156	15 ft. Dump Valve Cable Black	
2940-157	15 ft. Dump Valve Cable White	
2940-158	3 in. Y Harness Black----->	
2940-159	3 in. Y Harness White----->	
2940-160	5 ft Dump Valve Cable White	
2940-161	5 ft Dump Valve Cable Black	
2940-162	Dump Valve Harness at Compressor----->	
2940-163	20 ft Main Power Extension----->	
2940-164	5 ft CAN Aux To Air Harness----->	
2940-165	10 ft CAN Aux to Air Harness	
2940-166	VDM Power Cable with 40 Amp Breaker--->	

# Components, Kits, Accessories, & Ordering Numbers

2940-167  
2940-168

10 ft VDM Power Cable Extension----->  
20 ft VDM Power Cable Extension



2940-169

10 ft Cab to Hitch Extension----->



2940-170  
2940-171

10 ft CAN Aux to Air Harness Extension --->  
30 ft CAN Aux to Air Harness Extension



2940-181

Hyd. Compressor Solenoid/Switch Harness->



2940-182  
2940-189  
2940-190  
2940-192

20Ft Hyd. Compressor Control Harness----->  
10Ft Hyd. Compressor Control Harness  
Pneumatic RM Assembly (2940-001 - 004)  
Pneumatic RM Assembly (2940-005 - 006)



2940-209

CNH Adaptor Bracket (1260/1265 models) ->



2940-215

Air Adjust Wheel Mount W.A. ----->



2940-216

Air Adjust Narrow Wheel Mount W.A. ----->



2940-307

Draw Latch for compressor housing lid----->



2940-336

MAC Dump Valve----->



2940-337

3/8 Push to Connect (PTC) elbow 1/8 NPT->



2940-338

3/8 PTC Tee----->



2940-341

Air Tubing Cutter----->



2940-342

Ball Valve----->



2940-345

Black 3/8 Air Tubing 100ft roll----->



2940-346

Blue 3/8 Air Tubing 100ft roll----->



# Components, Kits, Accessories, & Ordering Numbers

2940-352	3/8 PTC Plug(package of 5)----->	
2940-357	Extreme Air Magnum Rebuild Kit----->	
2940-358	3/8 PTC Union, Straight----->	
2940-374	Tee-1)1/4"NPT male, 2)1/4"NPT female ----->	
2940-376	Updated Water Separator Drain Valve Kit-->	
2940-377	Compressor Pressure Switch----->	
2940-379	PQE Inlet Elbow 1/4 NPT to 3/8PTC----->	
2940-380	3/8 PC X 1/8 BSPP O-Ring Straight Fitting->	
2940-381	3/8PTC X 1/8BSPP O-ring Elbow Fitting---->	
2940-382	Shop Air Adapter----->	
2940-383	3/8 PC WYE Fitting----->	
2940-386	Shorter Air Bag----->	
2940-388	Larger Air Bag----->	
2940-390	Extreme Air Magnum Compressor & Filter->	
2940-391	100 AMP Compressor Relay, Continuous-->	
2940-395	Replacement Filter Element----->	



# Components, Kits, Accessories, & Ordering Numbers

2940-402	Full PQE Unit----->	
2940-404	Pressure Regulator (part of the 2940-415) →	
2940-408	3/8PTC Elbow Fitting 1/4NPT----->	
2940-415	Water Separator/Regulator Assembly----->	
2940-416	175PSI Tank Safety Relief Valve----->	
2940-430	20 ft Can Aux to Air Harness Extension----->	
2940-439	0 – 160psi Hydraulic Compressor Gauge--- →	
2940-441	Pressure Transducer----->	
2940-598	Plug Cap for Receptacle Protection----->	
2940-599	Plug Cap for Receptacle Protection(metal)→	
2940-609	45 Degree Air Fitting 3/8PC X 1/8NPT ---- →	
2940-635	3/8 PTC X 3/8 NPT 90 Degree Swivel ----->	
2966-293	CNH Adaptor Bracket----->	

# INTRODUCTION

The Yetter Electric Air Compressor assembly builds 145psi of air pressure and dispenses that air to the row cleaners' air bags as the operator commands it from the tractor cab. Yetter electric compressors are durably constructed and designed for easy integration to operate the Yetter 2940 Air Adjust System. The ability of the air adjustments allows the operator to adjust the row cleaner precisely on the move without leaving the tractor cab resulting in more acres planted. The precise adjustments give the row units and planter a more even, smoother ride leading to more accurate seed placement and seed depth resulting in a more uniform emergence. **IT IS NOT RECOMMENDED TO PLUMB ANY OTHER PNEUMATICALLY OPERATED SYSTEMS TO USE THE 2940 YETTER ELECTRIC COMPRESSOR AS ITS AIR SOURCE.**

## SYSTEM REQUIREMENTS

### POWER SUPPLY

The compressor and the VDM (Valve Drive Module) each use 12V from the battery.

The 2940-100 Cab Controller uses a switched power source. The 2940-153 will need connected to a switched power source. (Connector to the tractor not included)

**A CIGARETTE LIGHTER OUTLET ISN'T A SWITCHED POWER SOURCE AND THEREFORE SHOULD NOT BE USED.**

### SWITCHED POWER SOURCE CONNECTOR PART #'S:

**JOHN DEERE P/N:** RE67013

**CNH P/N:** 187103A1

**CAT P/N:** AG233356

### FUSE PROTECTION

To protect the compressor assembly & VDM from damage always ensure the integrity of the integrated 40 amp and 80 amp circuit breaker at the tractor battery where cable connects to the battery in case of short or over-circuit. When connected correctly, the tractor has a fuse to protect the cab controller located in the tractor's fuse panel. **NEVER MOUNT THE COMPRESSOR ASSEMBLY MORE THAN 50 FEET FROM THE BATTERY USING THE PROVIDED MAIN POWER CABLES. THIS WILL WEAKEN THE 80AMP BREAKER TO THE POINT OF FAILURE. IF MORE THAN 50 FEET IS NEEDED, BUILD POWER CABLE(S) TO LENGTH USING 00 GAUGE CABLE!**

### AIR COMPRESSOR MAINTENANCE

To prolong life expectancy of the compressor, clean the filter on a regular basis by removing the element from the housing, tapping it on a hard surface, exposed side down. This will empty the pleats of the filter of collected dust. If the dust has been wet or will not clean out, call Yetter to order a new element, part number 2940-395. You may lightly blow out the interior of the upper housing using an air tool. The housing and filter should be checked every two days of field operation, or more if conditions are very dusty.

**See pages 45 for further maintenance.**

### CONNECTIONS



**FAILURE TO LINE UP TABS WHEN PLUGGING MALE INTO FEMALE CONNECTORS CAN RESULT IN SHORT CIRCUIT. ALSO CHECK TAB AND SLOT SIZES, PLUGGING CONNECTORS IN BACKWARDS WILL RESULT IN FAULTY SYSTEM!!**

# 2940 AIR ADJUST SYSTEM INFORMATION

The 2940 Air Adjust Residue Manager control system consists of five primary components and kits. These parts include; Residue Manager (RM) or Residue Manager Coulter Combo Kit, Cab Controller, the Yetter Electric Air Compressor Assembly, Compressor Mounting Kit and the necessary Wires, Air Lines, and Fittings Kit.

## Residue Manager

## RM/Coulter Combo

Each of these kits will include the required brackets, wheel assemblies, & mounting hardware for installation to the row unit.



## Cab Controller

### 2940-100



The Cab Controller will use the RAM mount provided for installation in cab. Hold the POWER button to turn the cab controller on & press ENTER to activate the system. Make adjustments quickly & accurately during planting with the cab controller. Adjust up & down pressure to create the ideal "ride" or floating position for residue managers. Lift & down pressure settings can be adjusted independently. Down pressure can be increased to fix row cleaner in the rigid position. Five presets can be programmed within the controller for quick changes. Residue Managers can be raised as needed with a push of the Roman numeral I up button.

### RAM Mount



## Serial Number

There are 2 serial numbers to identify production dates & software.

### Cab Controller Serial Number

### VDM Serial Number



# Air Compressor Assembly



2940 Air Adjust requires a stable air supply source that can provide a minimum 145psi of clean, dry air. The 'clean, dry air' is a key component of the air supply, moisture within the air supply can shorten the life-cycle of the system. Another key component is having a leak free system to reduce the duty cycle and compressor hours, extending the service life.

## 2940-101 External Lay Out

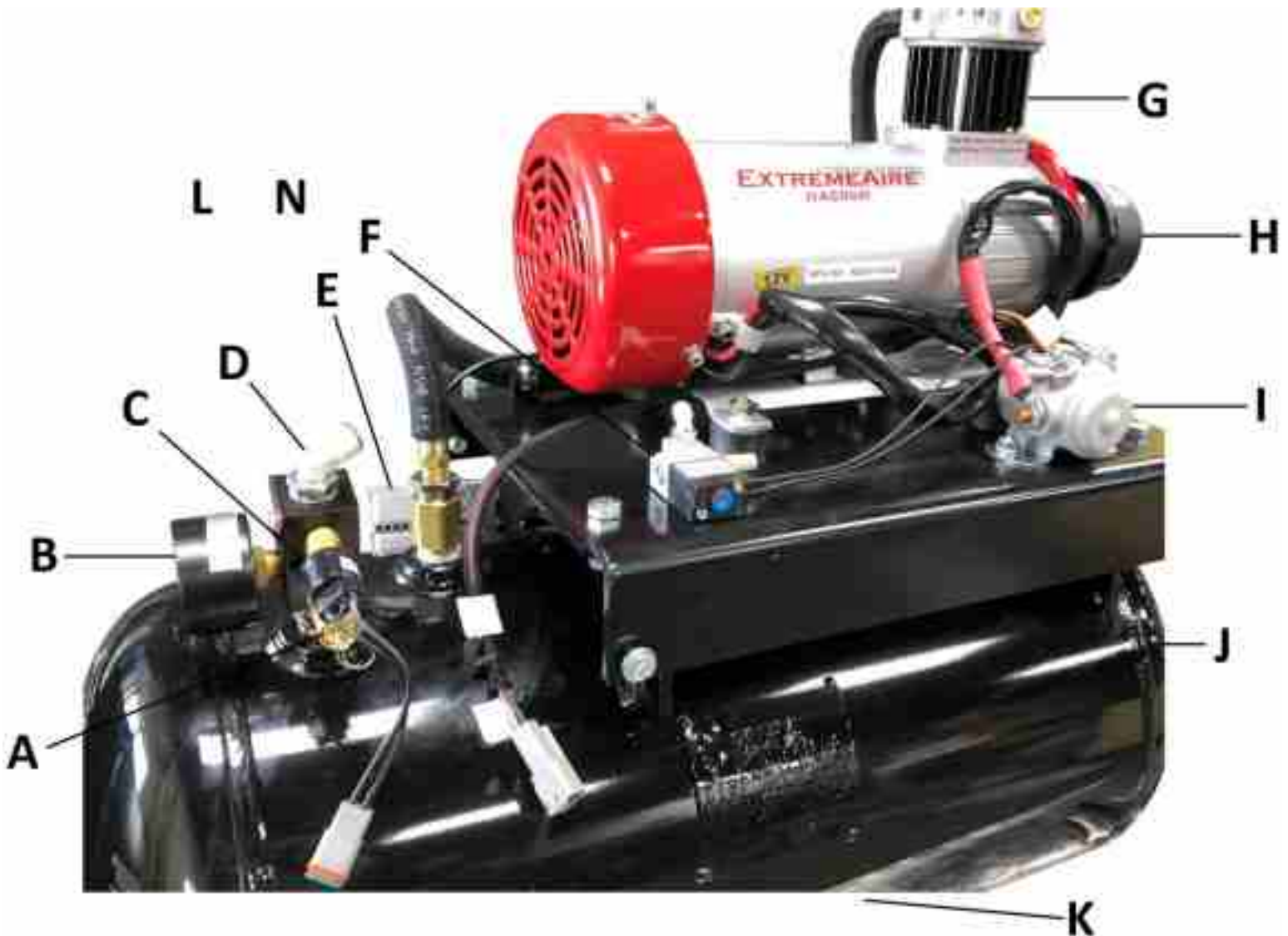

A – 2940-416 175psi Safety Relief Valve  
B – 2940-439 0 – 160psi Compressor Gauge  
C - 2940-377 Pressure Switch 125psi – 145psi

G – 2940-390 Electric Air Compressor  
H – 2940-395 Replacement Filter Element  
I – 2940-391 100 Amp Compressor Relay

D – 2940-635 3/8"PTC X 3/8NPT 90° Fitting  
E – No Part # Main Power Connector  
F – 2940-336 Head Pressure Relief Valve

J – 2940-440 12G Tank Assembly  
K – No Part # Tank Drain Valve

## Control Box

The 2940-103 control box communicates with the 2940-100 cab controller via the VDM and dispenses air out of the Pneumatic Quick Exhaust (PQE) as the operator commands it. The VDM is the valve drive module that is programmed to carry out each function of the system. **Serial # is located on the front of the VDM in the compressor assembly. See photo below.**



Serial Number Location

## 2940-103 Control Box External Lay Out

### 2018 – Present Model

- A. **WHEEL TRACK DOWN PRESSURE PORT**- Safely route black airline from the WT port to the inlet port of the down pressure dump valve on the center/wheel track rows of the planter. The down pressure on the center section residue managers (RM) or RM/Coulter Combo can be adjusted separately than the wing/outer sections down pressure to make up for tractor/planter tire compaction. WT should be set 2-5 psi heavier than RD. If the WT port is not used, install a plug (2940-352) to prevent air loss.
- B. **RESIDUE MANAGER DOWN PRESSURE PORT**- Safely route black airline from the RD port to the inlet port on the down pressure dump valves on the wing/outer sections of the planter. This port dispenses down pressure to the RM or RM/Coulter Combos on the wing/side of the planter.
- C. **RESIDUE MANAGER UP PRESSURE PORT**- Safely route blue airline from the RU port to the inlet port of the up pressure dump valves on each section of the planter. This port dispenses up pressure to each RM or RM/Coulter Combo on the planter.
- D. **12 PIN DEUTSCH CONNECTOR (BLACK)**- Depending on application, route 2940-164 or 2940-165 CAN AUX cable from rear of the tractor to this female connector. If the control box is mounted at the rear of the planter, 2940-170, 2940-171, or 2940-430 CAN AUX extensions will route to this female connector.
- E. **12 PIN DEUTSCH CONNECTOR (GRAY)**- Connect the 2940-162 dump valve cable and route to the dump valves. The 2 pin cable labeled RM UP DUMP (yellow/black wires) routes to all up pressure dump valves. The 2 pin cable labeled RM DOWN DUMP (orange/black wires) routes to all down pressure dump valves. The 2 pin cables labeled Aux 3 and Aux 4 are not used.
- F. **MAIN AIR SUPPLY INLET**- Plumb the 2940-367 250psi rated 3/8" airline from the hydraulic compressor to the inlet (water trap side) of the water separator/regulator assembly. Plumb 2940-345 3/8" black airline from outlet (regulator side) of the water separator/regulator assembly to this port.
- G. **ACCESSORY AIR OUTPUT**- Remove brass cap or plug to install fitting for miscellaneous uses. (ex: air tools) **DO NOT REMOVE WHEN SYSTEM IS PRESSURIZED!**
- H. **DUMP INLET**- Install the 1/4" airline from the bottom of the water separator into this port.
- I. **DUMP EXHAUST**- Install 1/4" airline in this port and route toward the ground. (this will drain condensation from the water separator)
- J. **COMPRESSOR COMMUNICATION CONNECTOR**- Sends power to the pressure switch & solenoid (see page 24)



## 2940-103 Control Box Internal Lay Out

2018 – Present Model

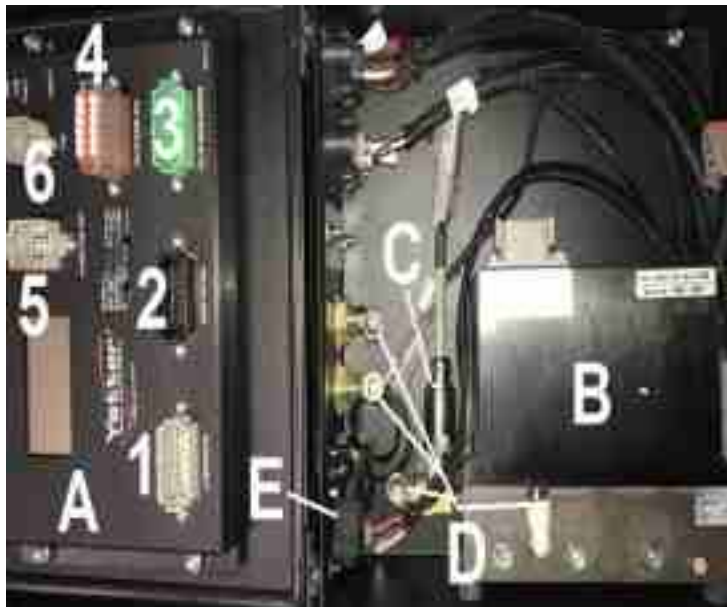

- |              |                                       |
|--------------|---------------------------------------|
| A – 2940-112 | VDM                                   |
| 1. J1        | Compressor Communication              |
| 2. J2        | Dump Valve Communication              |
| 3. J3        | PQE Communication                     |
| 4. J4        | Plugged(used only with 2940-054 kits) |
| 5. J5        | VDM Power and Ground                  |
| 6. J6        | Cab Controller Communication          |
| B – 2940-402 | PQE                                   |
| C – 2940-441 | Pressure Transducer                   |
| D – 2940-379 | PQE Inlet Elbow                       |
| E – 2940-376 | Water Separator Dump Valve            |

## Harness, Airlines, and Fittings Kit



12V-DC cables will be used to power the Compressor, VDM, Cab Controller, and Dump Valves. Flexible tubing will be used to move air from the external ports of the PQE to each air bag. Each kit will include pneumatic lines for both circuits, down and lift, as well as the fittings to make connections and cable ties to securely fasten the lines to the planter. Note: All 2940 Air Adjust kits include a tubing cutter within the kit.

The 2940-341 tubing cutter should be used for every cut to ensure a clean, square cut.



## **2940 Air Adjust Installation Guide Outline**

### **STEP 1: RESIDUE MANAGER (RM) OR RM/COULTER COMBO INSTALLATION**

**Residue Manager Only:** Install the RM Assembly using mounting hardware. When installing wheel mount assembly on the adjustment tube of the RM Assembly, place the top hole of the wheel mount to the 4<sup>th</sup> or 5<sup>th</sup> hole from the top of the adjustment tube for conventional tillage or mellow soils, 5<sup>th</sup> or 6<sup>th</sup> hole from the top for no/minimum till conditions. Install wheels on wheel mounts using hardware from the 2966-119 bolt bag. Install the RM wheels so that the left wheel leads, right wheel trails on the left side of the planter & the right wheel leads, left wheel trails on the right side.

**RM/ Coultter Combo:** Install the RM/Coultter Combo assembly using hardware from the 2940-128 bolt bag. Mount the coultter blade on the coultter arm hub & mount the RM wheels using the 5/8 Whiz Lock Nuts. RM wheels on combo units will install in the rear holes on both sides on all rows. It is recommended to set the coultter blade equal to or above seed depth. **Refer to the diagrams on pages 16 - 19**

### **STEP 2: INSTALLING 2940-100 CAB CONTROLLER**

Mount the 2940-100 Cab Controller & 2940-113 RAM Mount in the tractor cab. Position the Cab Controller within reach during operation without compromising safety/visibility from the cab. Connect the 2940-152 harness to the female 6 pin connector on the back of the cab controller & route the black CAN connector towards the hitch of the tractor. Connect the 2940-153 2 pin connector to the female 2 pin connector on the back cab controller. Splice the red & black wires to the appropriate connector to fit the tractor's switched power source. **Refer to the diagram on page 20**

### **STEP 3: INSTALLING COMPRESSOR ASSEMBLY & POWER CABLES**

**COMPRESSOR:** Begin by locating a suitable mounting location for the compressor assembly. Placement of the compressor assembly will vary on the make and model of the planter. Use mounts supplied or depending on application, **different mounts may need to be built**. NOTE: Be sure to check clearance of compressor assembly in all locations, especially noting tractor tires during turns, folding/unfolding the planter for transport mode, markers, and 2-point top link. The compressor must be mounted using 50 feet or less of main power cable extensions from the operating tractor's battery. If over 50 feet, heavier gauge power cables (00) must be built or purchased in the correct length.

**POWER CABLE:** Install the 2940-150 main power cable with 80amp breaker on the battery terminals (red is positive+, black is negative -). Next, connect the appropriate length of main power extensions (2940-151 or 2940-163) off of the 2940-150, route the main power extensions to large Anderson power connector coming out of the 2940-101A compressor assembly housing, & install. Install the 2940-181 Y harness on the compressor. **Refer to the diagram on pages 21 & 23**

### **STEP 4: CONTROL BOX AND HARNESS INSTALLATION**

**CONTROL BOX:** Mount the control box in a safe location with mounts/hardware supplied. Install the 2940-415 water separator/regulator assembly near the control box. Measure & cut the 2940-367 250psi rated 3/8" airline, install airline from outlet elbow on compressor into the 2940-415 inlet (water trap side). The regulator is preset to only allow 100psi of clean, dry air beyond it. Install 2940-345 3/8" airline from the 2940-415 outlet (regulator side) to control box inlet. Install 1/4" airline from the elbow on the bottom of the 2940-415 to the 1/4" PTC fitting closest to the door hinge on the side of the control box. Route 1/4" airline from remaining 1/4" PTC fitting on the 2940-103 toward the ground, as airline will dispense moisture.

**HARNESS:** Install the 2940-166 VDM power cable with 40amp breaker on the battery terminals (red is positive+, black is negative -). Install the appropriate length VDM power extension (2940-167 or 2940-168) off of the 2940-166, route to the hitch of the tractor to install into the matching connector on the CAN AUX to Air Harness. Lastly, install the CAN AUX to Air Harness, 2940-164 (5ft) or 2940-165 (10ft). The smaller Anderson power connector will connect to the VDM power extension, the black CAN connector connects to the other black CAN connector that routes to the cab controller, & the black male 12 pin Deutsch connector connects to the black female end on the side of the control box housing. 2940-170 (10ft), 2940-171 (30ft), or 2940-430 (20ft) CAN AUX to Air Extensions may be necessary if the control box is mounted further back on the planter than the hitch. Install the compressor communication harness, 2940-182 or 2940-189 into the 4 pin connector on the control box and route to the compressor and install into the 2940-181 Y harness. **Refer to the diagram on page 22 - 24**

### **STEP 5: DUMP VALVE & DUMP VALVE HARNESS INSTALLATION**

Install the dump valves (DV) to the planter as shown in the diagram that matches your planter. 16 row planters and less will have 1 up pressure & 1 down pressure DV on the middle of each wing/side & 1 up pressure & 1 down pressure DV on the wheel track (WT) or center rows. 24 row planters & larger will have 3 DVs per wing/side; 2 down pressure & 1 up pressure, & 2 DVs on the WT rows, 1 up pressure & 1 down pressure. Install the gray male 12 pin Deutsch connector of the 2940-162 into the gray female 12 pin Deutsch on the bottom side of the compressor assembly housing. The 2940-162 will have 4) 2 pin pig tails. The connector labeled RM Up Dump (yellow/black wires) will connect to all up pressure DVs using 2940-155 (30ft), 2940-157 (15ft), & 2940-160 (5ft) white DV harnesses. Use 2940-159 white Y harnesses to connect all white DV cables together. The connector labeled RM Down Dump (orange/black wires) will connect to all down pressure DVs using 2940-154 (30ft), 2940-156 (15ft), 2940-161 (5ft) black dump valve harnesses. Use 2940-158 black Y harnesses to connect all black DV cables together.

**CONNECTORS LABELED AUX 3 & AUX 4 WILL NOT BE USED! Refer to pages 24 - 36**

### **STEP 6: PLUMBING AIRLINES**

A group of airlines that route to the residue manager air bags are referred to as trunk airlines. The airline routing from the RU, RD, & WT to the inlet of the DV for the matching circuit is referred to as a supply airline. Start by routing the trunk airlines: route black (down pressure) & blue (up pressure) airline on each wing/side of the planter. If installing on a split row planter, keep the airline on the front rank residue managers on each wing plumbed separate from the back rank. When plumbing in the WT (wheel track) rows, use the center 4 or 6 rows that plant over the tractor & planter wheel tracks. If equipping on a narrow transport planter with 4 center rows & 6 rows are desired on the WT circuit, tie in the 1 row on each wing/side of the planter closest to the first & last center row. Use supplied tees to make enough open ports in each circuit to install supply airline to the inlet port of each DV of the matching circuit. Also use tees to connect the outlet port of the DVs to the matching circuits of the trunk airlines. On split row planters, a ball valve will be used to shut air off to bean rows when planting corn. **Refer to the diagrams on pages 25 - 37**

### **STEP 7: PERFORM A PRE-OPERATION TEST OF THE SYSTEM**

Now that the system is installed, perform a pre-operation test. Start by folding/unfolding & lowering/raising the planter to check for enough slack in airline & in harnesses at hinge points. Check all electrical connections, cables, & airline making sure nothing was damaged. Next, turn on the cab controller by holding the power button. After the cab controller is on, turn all pressures (RU, RD, and WT) to 0psi & press ENTER to activate the system. The compressor will turn on, build to 95psi & turn off. Check the interior of the compressor housing (PQE, Pressure on Valve, & airline within the housing) for leaks. Apply 30psi to the RU port & watch your row cleaners as they should all rise to maximum up travel. Check for leaks on all up pressure circuits & fittings. When that leak check is finished, turn RU to 0psi & turn RD & WT to 30. Check all down pressure airline & fittings in these circuits for leaks & repair as needed. **Refer to page 42 - 44**

## **Residue Manager(RM) Installation**



**ENGAGE THE CYLINDER STOPS ON THE PLANTER LIFT WHEELS TO "LOCK" THE PLANTER IN THE UP POSITION**

### **Installation overview:**

- Prior to installation of each RM mounting bracket assembly, check the freedom of motion of the parallel linkage or pivot arm.
- The installation process should be done with the planter raised, half folded for transport, & the row units fully extended down.
- Install the 2940 RM or RM/Coulter Combo mounting bracket assembly centered & level side to side on each planter row unit.
- If planter manufacturer is John Deere & equipped with HD scrapers on the True V opener blades, a 2940-049 kit will need installed to space the RM or RM/Coulter Combo mounting bracket assembly out to avoid interference. **(See page 48)**

### **For John Deere, Kinze, & White Models Installing RM Only**

**Step 1:** Place 1) Pneumatic RM Assembly, 1) Mounting Hardware Bolt Bag (2940-142), 1) Wheel Mount Weld Assembly (2940-215 or 2940-216), 1) RH Wheel Assembly (2966-140), 1) LH Wheel Assembly (2966-141), & 1) Wheel Mount Bolt Bag (2966-119) at each planter row unit. Install the Pneumatic RM assembly using 3) 1/2" X 1-1/2" GR5 bolts, 6) 1/2" flat washers, & 3) 1/2" lock nuts. Use the diagram below for hole alignment, as well as direction of the mounting bolts. Tighten the hardware.

**Tools needed are 3/4 socket, 3/4 wrench, impact, & 10" extension.**



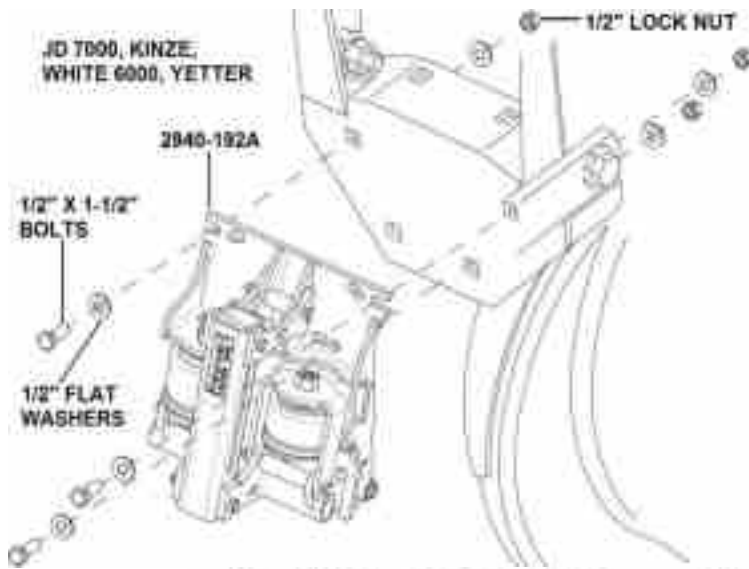

**JD 1700, AGCO 9000**

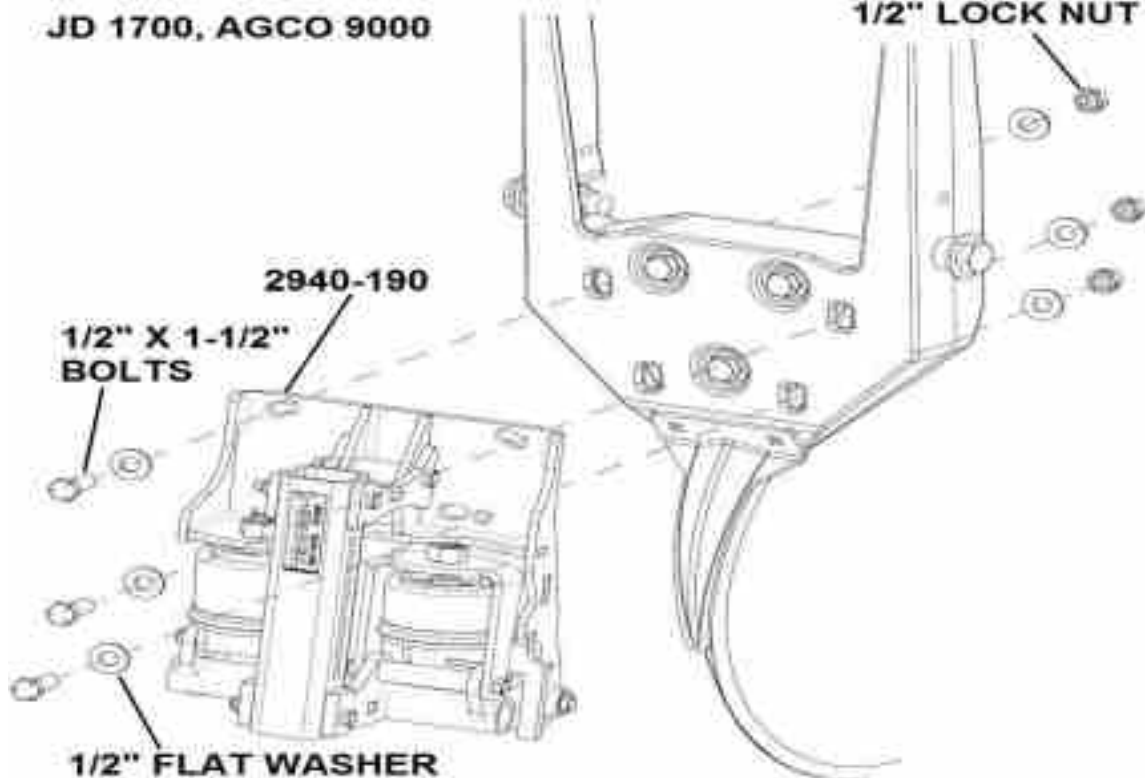
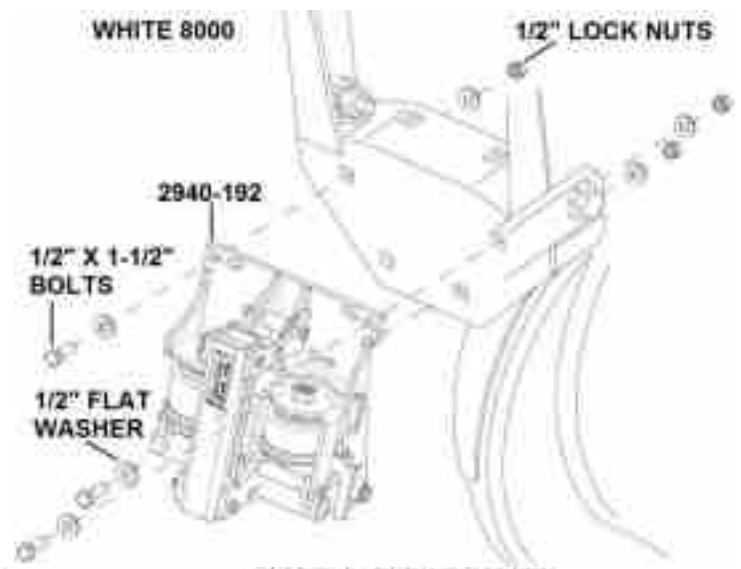

**NOTE: AGCO 9000 units will use 1/2" x 2" mounting bolts!**  
**For Case Models Installing RM Only**

**Step 1: 800 – 1200 SERIES:** Place 1) Pneumatic RM Assembly (2940-190), 1) CNH Adaptor Bracket (2940-209), 1) CNH Mounting Bolt Bag (2940-145), 1) Wheel Mount (2940-215/2940-216), 1) Cyclo Stop Casting Bolt Bag (2965-135), 1) RH Wheel Assembly (2966-140), 1) LH Wheel Assembly (2966-141), & 1) Wheel Mount Bolt Bag (2966-119), & 2) Bearing Shields (2967-392) at each row unit. Mount the 2940-190 to the 2940-209 using 3) 1/2" X 1-1/2" GR5 bolts (note the bolt direction), 3) 1/2" flat washers, & 3) 1/2" lock nuts. Mount this assembly to the row unit attachment casting using 2) 1/2" X 3-1/2" bolts & 2) 1/2" lock nuts. Install the 2) Cyclo Stop casting pieces to each upper parallel arm using either A) 3/8 X 1-1/4" bolts, 3/8 washer (not shown), & 3/8 lock nuts or B) 1/2" X 1-1/4" bolts & 1/2" lock nuts. Note the direction of the mounting bolt.

**2100 SERIES:** Place 1) Pneumatic RM Assembly (2940-190), 1) Mounting Hardware Bolt Bag (2940-142), 1) Wheel Mount W.A. (2940-215/2940-216), 1) RH Wheel Assembly (2966-140), 1) LH Wheel Assembly (2966-141), & 1) Wheel Mount Bolt Bag (2966-119), & 2) Bearing Shields (2967-392) at each planter row unit. Use the same bolt direction as below. The top to mounting bolts will be the same as diagram below. Use the bottom hole that is aligned with the OEM CNH faceplate adaptor.

Tools needed are 3/4 socket, 9/16 socket, 3/4 wrench, 9/16 wrench, impact wrench, & 10" extension.

## 800 - 1200 SERIES 2100 SERIES

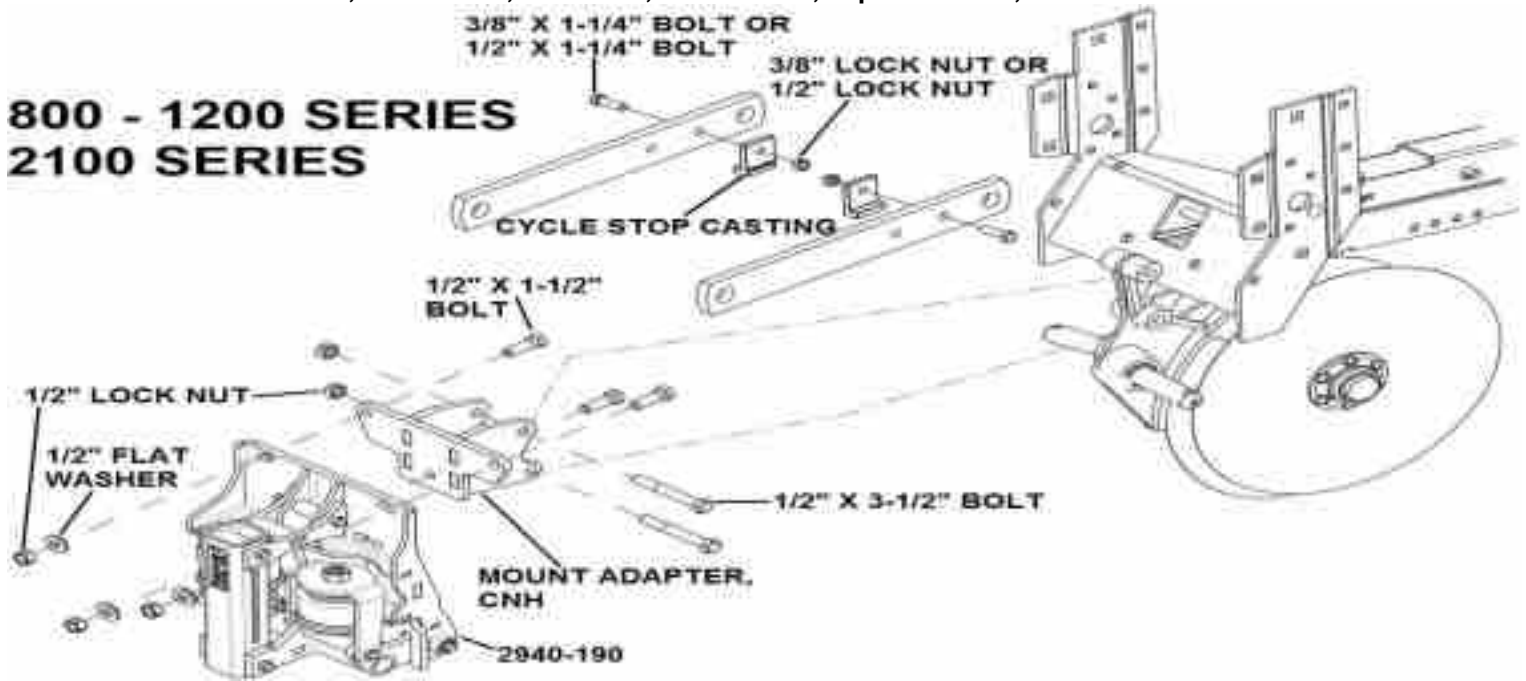

**Step 2:** Install 1) 2940-380 3/8" PTC X 1/8" BSPP male fitting to each air bag using an 11/16 wrench. Do not over tighten.

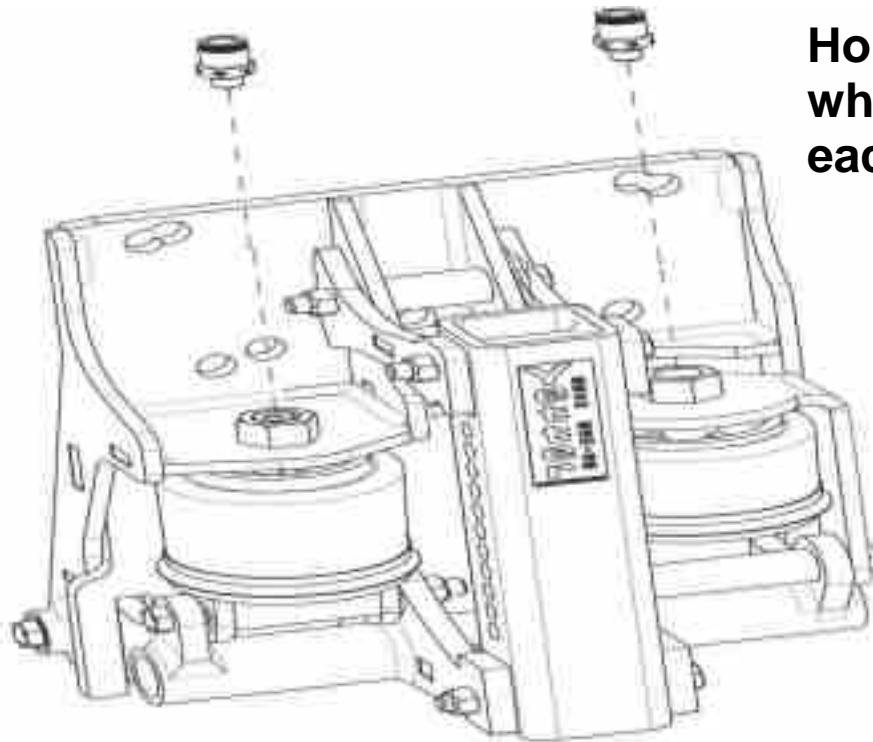

**Hold the air bag  
while tightening  
each air fitting.**

## Residue Manager Installation Con't

**Step 3:** Install the Wheel Mount (2940-215 or 2940-216) on the adjustment tube of the mounting bracket assembly. Recommended mounting location is 5<sup>th</sup> hole down from the top of the adjustment tube mounts to the top hole of the wheel mount. Adjustments may need to be made depending on tillage practice, soil conditions, and/or residue thickness. **Tools needed are a 9/16 socket, 9/16 wrench, impact, and a 10" extension.**

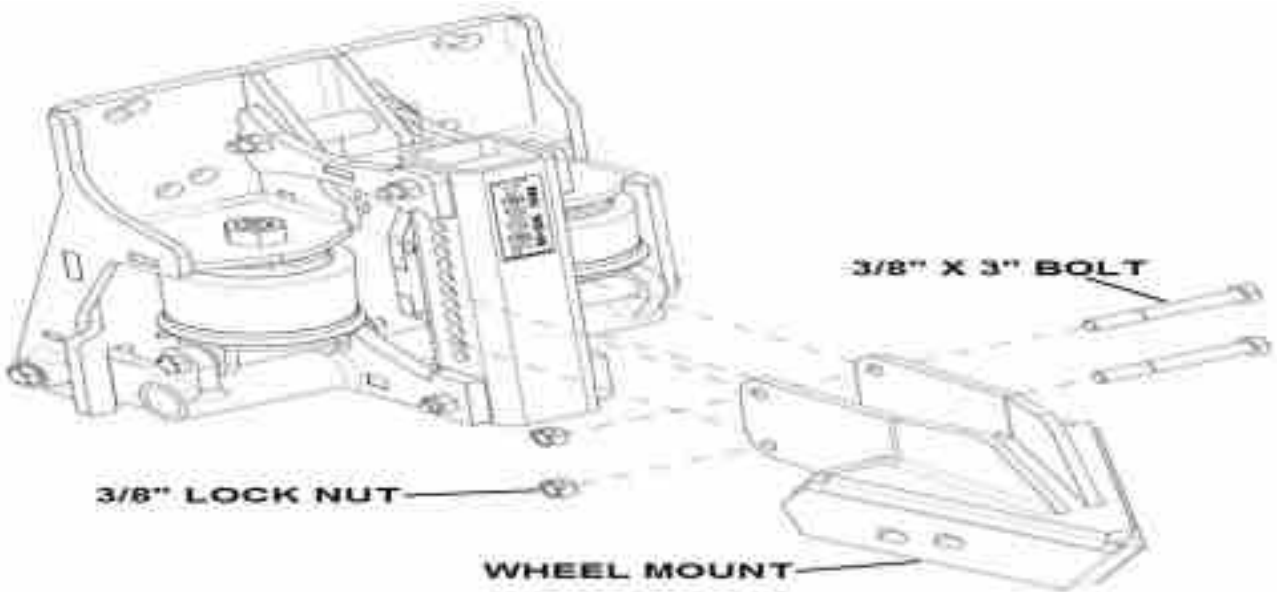

**Step 4:** Mount the RM wheels on the wheel mount using 2) 5/8" lock washers & 2) 5/8 hex nut. Mount the wheels so the left side of the planter has the left wheel leading, right wheel trailing. Mount the wheels so that right side of the planter has the right wheel leading, left wheel trailing. Right & left is determined by standing behind the planter looking at the tractor or sitting in the tractor facing forward. Diagram below is proper installation for the right side of the planter. **Tighten using a 15/16 wrench. (Ratcheting wrench if available)** Note: Properly install row cleaner wheels so that wheel teeth curve back when entering field debris.

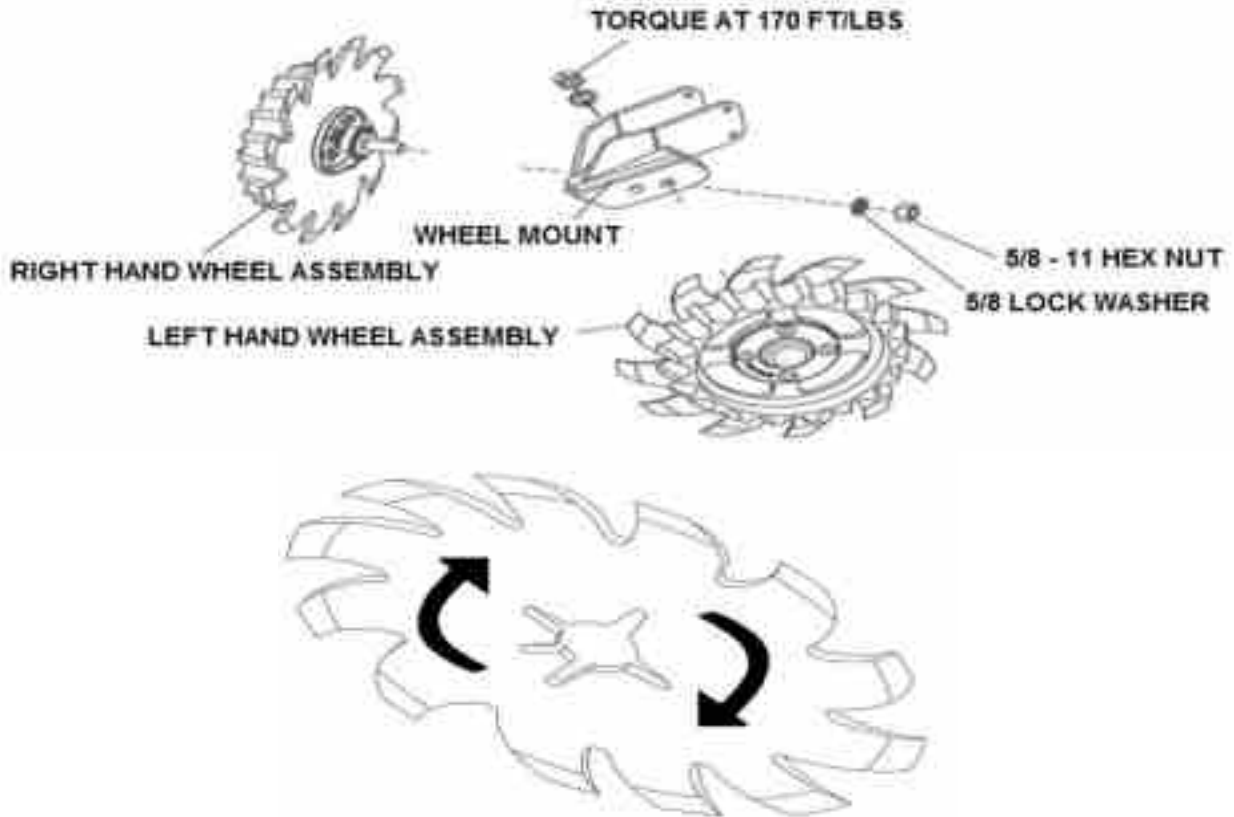

**It is highly recommended to wear gloves & use caution when tightening wheels!**

# RM/Coulter Combo Installation

**Step 1:** Place 1) RM/ Coulter Combo assembly, 1) Coulter Blade, 1) Mounting Bolt Bag (2940-128), 1) RH wheel assembly (2966-116), & 1) LH wheel assembly (2966-117) at each row unit. Mount the RM/Coulter Combo assembly to the row unit face plate using 3) 1/2" X 1 1/2" bolts and 3) 1/2" lock nuts. See the diagrams below for bolt alignment and bolt direction. Tighten hardware.

**Tools needed are 3/4" socket, 3/4" wrench, impact, & 10" extension.**

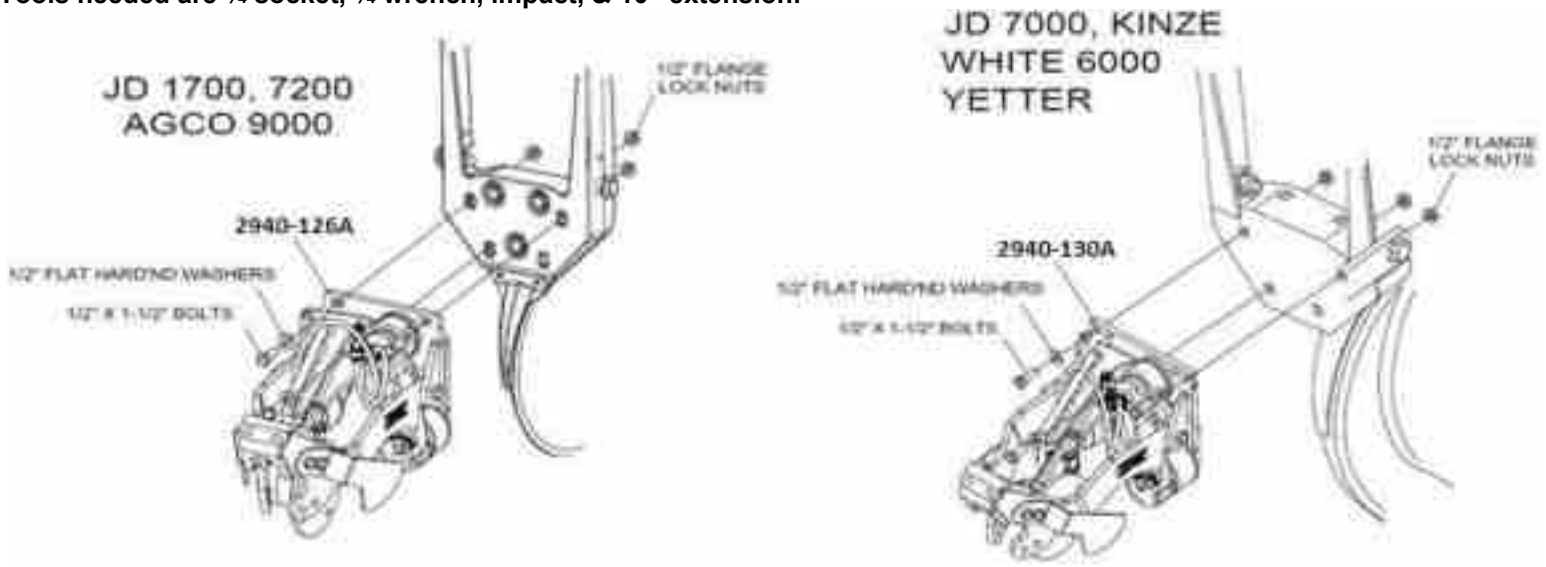

**Step 2:** Install coulter blade using 4) 1/2"X1 1/4" bolts & 4) 1/2" lock nuts using a 3/4" socket, 3/4" wrench, impact, & 10" extension.

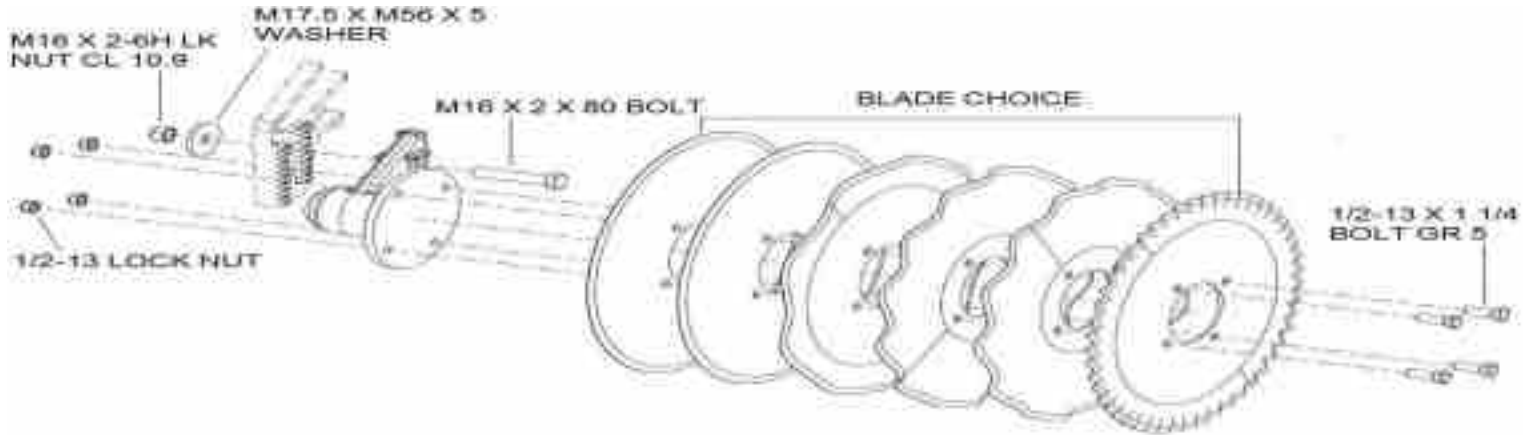

**NOTE:** Adjust coulter blade depth equal to or above the planter opener blades. Adjust the blade depth as required for blade wear. Planter double disc blades that are worn to 14 1/4" or smaller in diameter should be replaced. Example: 14 1/4" blades will have a 3/8" shallower planting depth than 15" blades at the same gauge wheel adjustment setting.

**STEP 3:** Install each of the RM wheels in the rear D-bolt holes using a 5/8 serrated flange nuts & tighten using a 15/16" wrench.

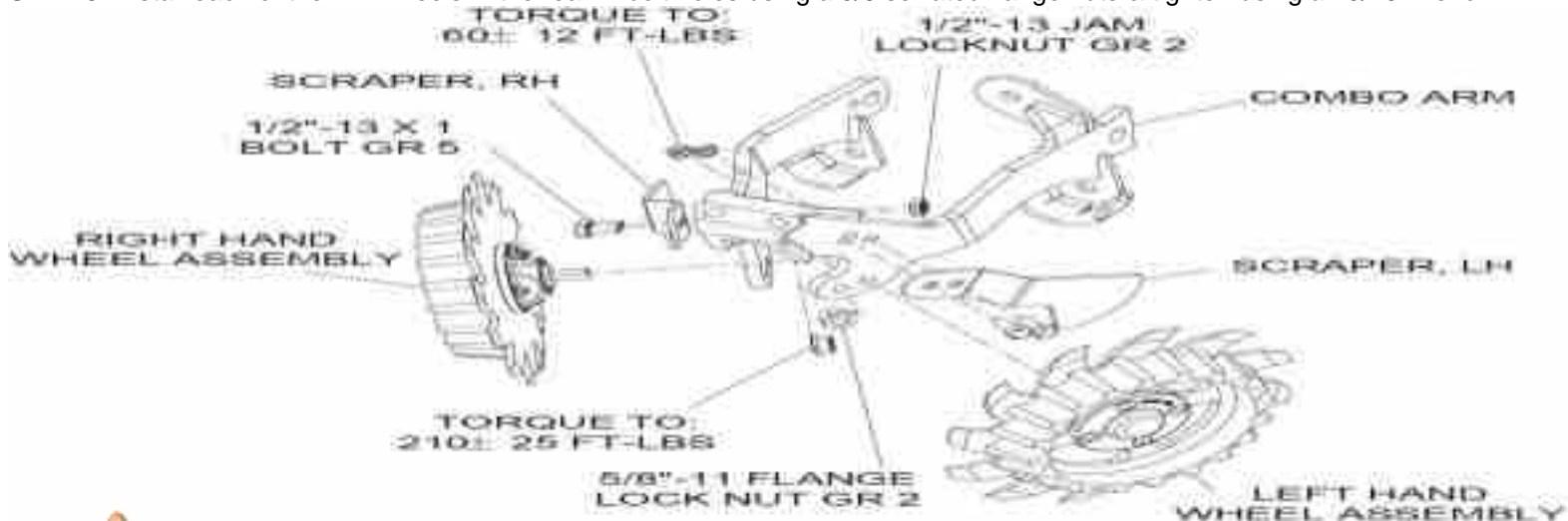

**It is highly recommended to wear gloves & use caution when tightening wheels!**

# Yetter Cab Controller Installation (Skip this page if using ISOBUS monitor)



**Step 1:** Begin installing the 2940 Air Adjust cab controller once an adequate mounting location has been found. Fix the base component of the 2940-113 Mounting Bracket in place. Use items labeled B if mounting to a slotted, flat mounting system using a ratchet, 11mm socket, & 11mm wrench to tighten the hardware. Use items C if using a tubular mounting system. 2 different sized U-bolts are provided for tubular mounting systems. Use a ratchet & 5mm socket to tighten the hardware.

**Step 2:** Connect the mount bracket to the rear of the controller using 4) M5 Hex Nut and 4) M5 split washers (labeled A) using a ratchet & 8mm socket to tighten the hardware. Set the cab controller in place and tighten the clamp by turning the handle clockwise.

**Step 3:** Attach the male 2 pin connector of the 2940-153 to the female 2 pin connector on the 2940-100 Cab Controller. Install the connector not provided for your tractor at the bare end of the 2940-153 and connect to tractors switched power source. **The cigarette outlet is NOT a switched port on all models of tractors, and therefore should not be used.**



### Switched Power Source Connector part #'s:

**JOHN DEERE PART #: RE67013**

**CNH PART #: 187103A1**

**CAT P/N: AG233356**

**Step 4:** Route & install the 2940-152 hitch to switch panel wire harness from the rear 6 pin connector of the 2940-100 Cab Controller to the hitch-point at the rear of the tractor. The black CAN connector of the 2940-152 will connect to the 2940-164 or 2940-165 CAN AUX to Air Harness. **(See page 23 for further details)** If an extension is needed between the 2940-100 Cab Controller and this harness, a 2940-169 10ft cab to hitch extension is available to order.



# INSTALLING 2940 AIR COMPRESSOR ASSEMBLY

**Step 1:** Every planter/tractor combination will contain its own unique situations in regard to mounting the 2940 Compressor Assembly for clearance and accessibility. **YOU SHOULD EXERCISE YOUR OWN BEST JUDGEMENT TO FIT YOUR SITUATION.** Begin by locating a suitable mounting location for the compressor assembly. Placement of the compressor assembly will vary on the make and model of the planter. Use mounts supplied or depending on application different mounts may need to be built. NOTE: Be sure to check clearance of compressor assembly in all locations, especially noting tractor tires and folding/unfolding the planter for transport mode, markers, and 2-point top link.

**Step 2:** Visually inspect the proposed mounting location for structural stability and to find signs of wear in that location. Possible obstructions to be aware of include marker arms, liquid fertilizer tanks, rear tires (duals especially) during tight turns, 2 point top link, etc...

**Step 3:** Mark out the position of the Compressor then complete a cycle of folding/unfolding to transport mode and raising/lowering of the planter; as well as, driving in a tight circle in one or both directions, in planting position, to verify or identify obstructions.

**Step 4:** Once the compressor is mounted, repeat the previous process very cautiously to once again verify that the compressor is clear of obstructions.

Always mount the compressor in the vertical position, housing above the tank.

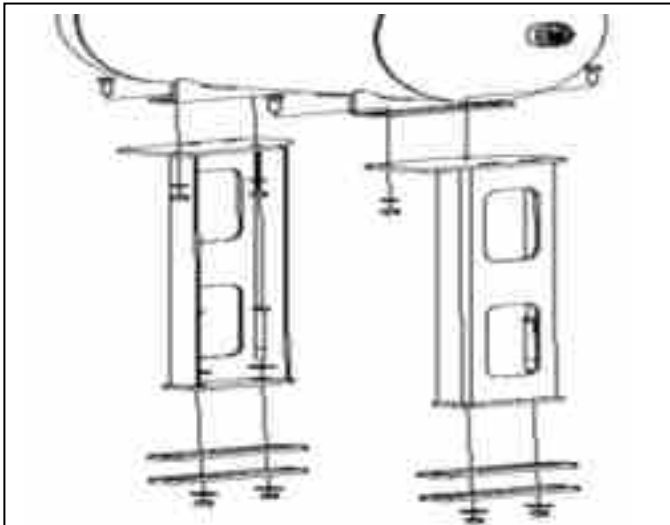

**2940-085** – Mounting Kit is designed for mounting to the 2 point cross hitch on the planter, or areas that require higher elevation for clearance. Different size bolts may be needed.

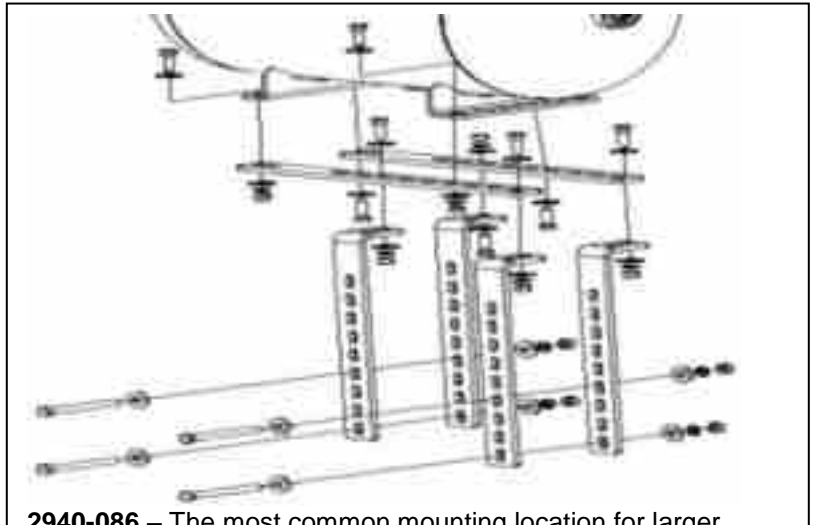

**2940-086** – The most common mounting location for larger planters will be on the draft bar. Use the 2940-086 mounting kit for situations that require mounting elsewhere on the planter than the hitch. This will allow the compressor to be elevated & offset to avoid clearance issues. Different size bolts may be

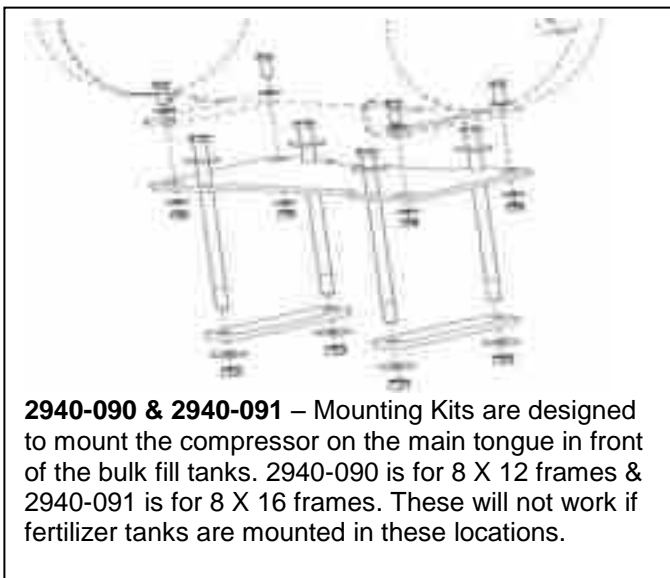

**2940-090 & 2940-091** – Mounting Kits are designed to mount the compressor on the main tongue in front of the bulk fill tanks. 2940-090 is for 8 X 12 frames & 2940-091 is for 8 X 16 frames. These will not work if fertilizer tanks are mounted in these locations.

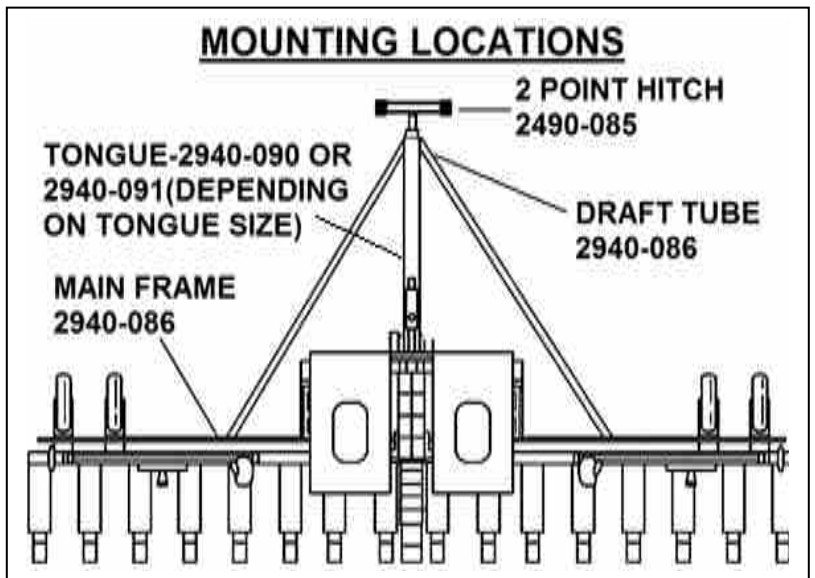

**Refer to pages 60 for Part Identification.**

**In some situations, mounting brackets may need to be built to fit your planters set-up.**

# 2940-103 Control Box Installation

The 2940-103 Control Box is an assembled unit that utilizes compressed air supplied by the OEM hydraulic compressor to operate the 2940 Air Adjust System. In some situations, a mount may need to be built to install the 2940-103 in an adequate location. OEM ELECTRIC COMPRESSORS ALREADY ONBOARD PLANTERS WILL NOT OPERATE YETTER 2940 AIR ADJUST SYSTEMS!

## 2940-103 MOUNTING GUIDE

2940-082 (See page 59 for diagram)



2940-083 (See page 59 for diagram)



2940-084 (handrail by compressor)



2940-084 (handrail between bulk fill tanks)



(See page 59 for diagram of the 2940-084)

## Water Separator/Regulator Installation

Install the 2940-415 water separator/regulator assembly near the control box in a suitable location out of harm's way. The water separator removes moisture from entering the system's control box. Install the assembly with the water trap vertical & the elbow fitting towards the ground. The regulator (2940-404) should be set to only allow no more that 100psi into the control box. Below are some examples of mounting locations for the water separator/regulator assembly.



# Airline Routing –Compressor to Control Box

## If using a Yetter Electric Compressor

**Step 1:** Install 2940-367 250psi rated 3/8 airline from the compressor outlet to the inlet port (water trap side labeled A) of the water separator.

**Step 2:** Install 2940-345 3/8" black airline from the outlet port of the water separator (labeled B) to the inlet port (labeled 1) on the control box.

**Step 3:** Install 1/4" airline from 1/4"PTC elbow (labeled C) on water separator to the 1/4"PTC fitting (labeled 2) closest to the door hinge on control box.

**Step 4:** Route 1/4" airline from 1/4"PTC fitting (labeled 3) on side of control box toward the ground making sure the end of the airline is not pointed toward anything that moisture may damage or rust.



## Compressor Power Cable and Harness Installation

**Step 1:** Install the 2940-150 main power cable with 80A breaker and the 2940-166 VDM power cable with 40A breaker on the operating tractor's battery. Red cable installs on the positive (+) battery terminal post and the black cable installs on the negative (-) battery terminal post.



**Step 2:** From the open 2 pole Anderson connector of the 2940-150, safely route & install the appropriate length of main power extension cables, 2940-151 is a 10ft main power extension & 2940-163 is a 20ft main power extension, into the Anderson connector that comes out of the bottom of the compressor housing. If operating tractor is articulating or if compressor is further back on the planter than the hitch, more extension cables may be needed. **Cable length from the battery to the compressor should not exceed 50 feet. Longer than 50 feet distances cause the 80A breaker to become weak and trip often. If distance is greater than 50 feet, heavier cable needs made using 00 gauge wire.**



**Step 3:** From the open Anderson connector on the 2940-166, safely route/install the appropriate length of VDM power extension cables, 2940-167 (10ft) extension & 2940-168 (20ft) power extension, to the hitch of the tractor. At the hitch of the tractor, place the open 2 pole Anderson connector next to the black CAN connector that routes to the cab controller, these are the disconnecting points when unhooking the planter from tractor.



**Step 4:** Install the 2940-164 5ft CAN AUX to Air harness or 2940-165 10ft CAN AUX to Air harness. The black CAN connector connects to the other black CAN connector that comes from the cab controller. The small Anderson connector connects to the VDM power extension that routes to the battery. The male black 12 pin Deutsch connector installs into the black female 12 pin Deutsch connector located on the bottom of the compressor housing. If the compressor assembly is located further back on the planter than the hitch, CAN AUX to Air extension harnessing may need to be purchased. 2940-170 is 10ft extension, 2940-171 is 30ft extension, & 2940-430 is a 20ft extension.





# Electric Communication Harness (Only if application is using the Yetter Electric Compressor)

**Step 1:** Install the 2940-181 hydraulic compressor solenoid/switch harness; the male 2 pin connector installs into the female connector on the On/Off solenoid on the hydraulic block on the side of the compressor housing, the female 2 pin connector installs into the male 2 pin connector on the pressure switch.

**Step 2:** Connect the 2940-189 10 foot control harness to the 4 pin connector of the 2940-181 & route to control box. If more length is needed, call Yetter & order more. (2940-182 is 20 foot length; 2940-189 is 10 foot length)

**Step 3:** Connect the 2940-182 or 2940-189 into the 4 pin female connector on the side of the control box.

## 2940 -136 Dump Valve Kit Installation

**Step 1 -** Align the holes on valve (8) with mounting plate (3) holes. Insert bolts (5) through the aligned holes and start the nuts (4) on the threads. Tighten nut with 1/4" wrench while holding bolt with a Phillips screwdriver until tight.

**Step 2 -** Install supplied 6" piece of airline (6) in port 1, the vent elbow (7).

**Step 3 -** If install is on a John Deere planter, use flat flanged nut (1) to install Dump Valve assembly by placing circle cut out on mounting tab (3) on U-bolt used to mount the row unit to planter toolbar. Pinch mounting tab (3) between existing nut on U-bolt & the flat flanged nut (1). If install is on any other OEM planter, use the serrated flanged nut (2) for the install of the dump valves.

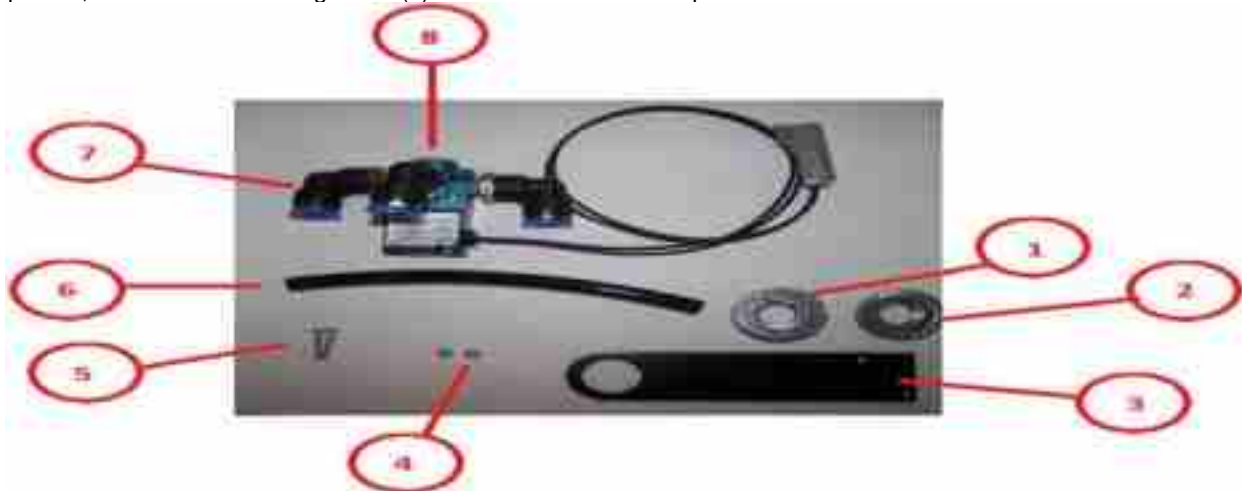

**Solenoid Down**



**Single Dump Valve Mounting**



**Solenoid Up**



**Dual Dump Valve Mounting**



**See pages 26 – 36** for dump valve & dump valve harness installation. Dump valve placement will vary depending on planter size. Dump valve cable length will vary depending on planter model & row spacing. White dump valve cables are to be used on all lift circuit (blue airline) dump valves. Black dump valve cables are to be used on all down pressure (black airline) dump valves.

## Airline Routing-Planter Frame

Below is a suggested method for safely & securely routing the airlines on the planter frame whether installing trunk airlines (airlines routing to the row cleaner air bags) or supply airlines (airlines that route from the compressor housing to the dump valve's inlet port). Safely route the airlines on the frame that the row units are mounted to or follow the path to which the hydraulic hoses on the planter are routed. After airline & dump valve harnessing is complete, use provided zip ties to keep parts away from pinch & wear points.



## Airline Routing-Row Unit

Below is a suggested method for safely and securely routing the airlines from the air bag to the tees on the planter frame. These are generalizations and **YOU SHOULD USE YOUR OWN BEST JUDGEMENT** in routing airlines. DO NOT pass the airlines between the rear of the parallel arm & the row unit. DO NOT pass airlines between the frame & the head plate used to mount the row unit to the planter frame. These can act as both a pinch points & wear points. If necessary, use provided zip ties to keep airlines away from pinch & wear points & sharp or rotating objects that may damage the airline.



Specific airline routing will be dependent upon: Row unit make & model (AGCO, CNH, JD, Kinze, etc), row unit spacing (15", 20", 22", 30", 36", etc), parallel arm length, & other variables. RM units will have 1 up pressure & 1 down pressure air bag & RM/Coulter Combo models will have 2 air bags on the bottom of the bracket for up pressure & a single air bag on top is for down pressure. The 2 up pressure air bags will have airline already tee'd together so the lift pressure trunk airlines will need plumbed to that tee.

## Airline Routing

**The following pages are dump valve & airline diagrams of different planter models. Dump valve cable length may vary from the directions given. For example, a 24 row planter on 30 inch centers will have different length dump valve cables than a 24 row planter on 20 inch centers. The wiring & tubing kit will have everything needed to complete the installation.**

Direction of flow is: Supply Tank → Water Separator Assembly → Control Box → Dump Valves → Air Bags All airlines will be 3/8". Blue airline should be used on all lift pressure (smaller) air bags & black airline should be used on all down pressure (larger) air bags. Use the airline colors to differentiate the lift pressure (Blue Airline) and down pressure (Black Airline) on the planter for troubleshooting, leak detection, & dump valve circuit indication. Route the airlines as efficiently and conveniently as possible.

**If there is no diagram for your situation, contact a Yetter service representative (800-447-5777) & a drawing will be made.**

# 6 Row Dump Valve Diagram

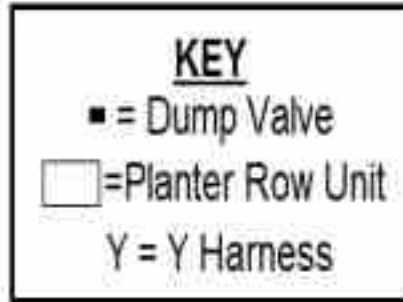

Down  
Pressure  
Dump Valve

Row



Routes to the 2  
pin pigtail  
labeled RM  
DOWN DUMP



Up  
Pressure  
Dump Valve

Row

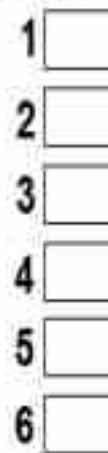

Routes to the 2 pin  
pigtail labeled RM  
UP DUMP



**Step 1:** Install 1 dump valve on row 3 & 1 dump valve on row 4.

**Step 2:** Install the male 12 pin Deutsch connector of the 2940-162 dump valve cable into the **GRAY** female connector on the side of the 2940-101 compressor housing.

**Step 3:** Install the mating 2 pin connector of the 2940-156 black dump valve cable to the dump valve on row 3 & route the other end of the 2940-156 to the 2 pin connector labeled RM DOWN DUMP (orange/black wires) on the 2940-162 from step 2 & install.

**Step 4:** Install the mating 2 pin connector of the 2940-157 white dump valve cable to the dump valve on row 4 & route the other end of the 2940-157 to the 2 pin connector labeled RM UP DUMP (yellow/black wires) on the 2940-162 from step 2 & install.

★ Aux 3 & Aux 4 on 2940-162 are not yet used ★

# 6 Row Airline Diagram

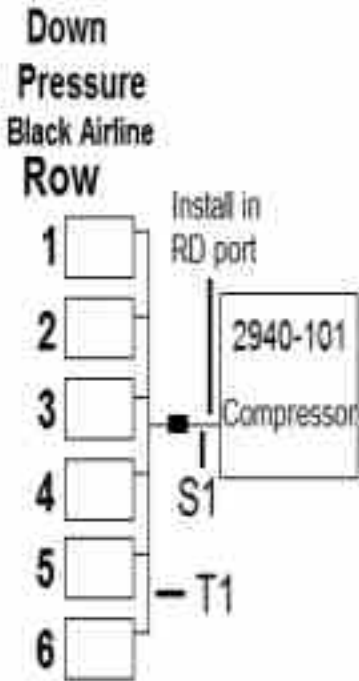

**Step 1: T1 & T2** Route blue & black airline from row 1 to row 6. Install the black airline in the down pressure (larger) air bag & the blue airline in the up pressure (smaller) air bag. Trace both airlines back to row 1 installing tees in each (blue & black) airline at each row unit. From each tee in the up pressure (blue airline) circuit, route blue airline to the up pressure-air bag and install in the fitting. From each tee in the down pressure (black airline) circuit, route black airline to the down pressure air bag and install in the fitting. When back to row 1, cut each airline to length & install each airline into the matching air bag.

**Step 2:** On row 3 at the down pressure dump valve, install a tee in the black airline installed in step 1. Install black airline from the open port on the tee to the outlet port on the dump valve.

**Step 3:** On row 4 at the up pressure dump valve, install a tee in the blue airline installed in step 1. Install blue airline from the open port on the tee to the outlet port of the dump valve.

**Step 4: S1** Route black airline from the RD port on the 2940-101 compressor housing to the inlet port on the down pressure dump valve on row 3.

**Step 5: S2** Route blue airline from the RU port on the 2940-101 compressor housing to the inlet port of the up pressure dump valve on row 4.

**Step 6:** Install a plug (2940-352) into the WT port on the 2940-101 compressor housing to prevent air loss. Another way to do this is to cut a finch piece of black airline, install one end into the WT port, fold the airline over causing a kink, & zip tie the airline to stay like this. This circuit will not be used with this size of planter.

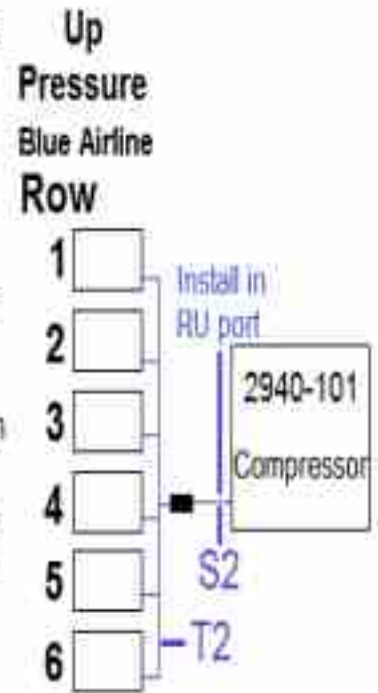

**KEY**

■ = Dump Valve

□ = Planter Row Unit

T1-2 = Trunk Line

S1-2 = Supply Line

# 6/11 or 6/12 Split Row Dump Valve Diagram

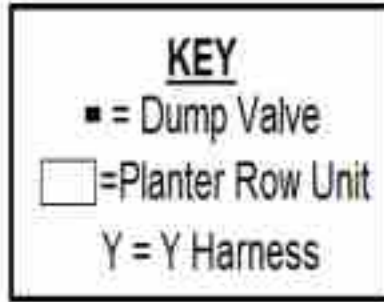

Down  
Pressure  
Dump Valve  
Row

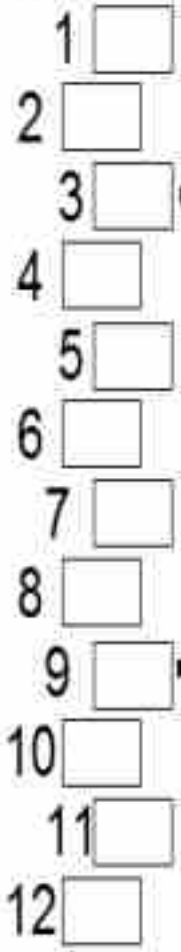

Routes to the 2 pin pigtail labeled RM DOWN DUMP

- Step 1:** Install 2 dump valves on row 3 and 2 dump valves on row 9.
- Step 2:** Install the male 12 pin Deutsch connector of the 2940-162 dump valve cable into the **GRAY** female connector on the side of the 2940-101 compressor housing.
- Step 3:** Route & install 15 foot length of black dump valve cable (2940-156) from the 2 pin connector of 1 dump valve on row 3 to 1 dump valve on row 9. Use a black "Y" harness (2940-158) to connect the down pressure dump valve on row 9 to the 15 foot black dump valve cable routed from row 3's down pressure dump valve. From the remaining open connector on the black "Y" harness, route the necessary length of black dump valve cable to reach the 2 pin connector labeled RM DOWN DUMP (orange/black wires) on the 2940-162 harness installed in step 2.
- Step 4:** Route & install 15 foot length of white dump valve cable (2940-157) from the open 2 pin connector of the up pressure dump valve on row 3 to the up pressure dump valve on row 9. Use a white "Y" harness (2940-159) to connect the up pressure dump valve on row 9 to the 15 foot white dump valve cable routed from row 3. From the remaining open connector on the white "Y" harness, route the necessary length of white dump valve cable to reach the 2 pin connector labeled RM UP DUMP (yellow/black wires) on the 2940-162 harness installed in step 2.

Up  
Pressure  
Dump Valve  
Row

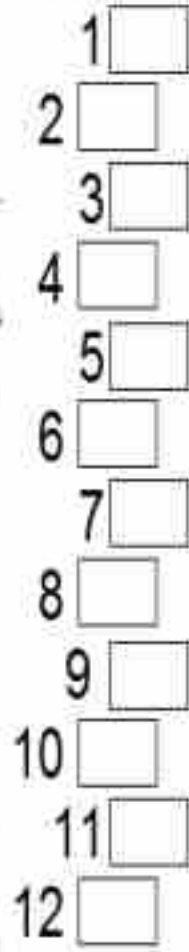

Routes to the 2 pin pigtail labeled RM UP DUMP

★ Aux 3 & Aux 4 on 2940-162 are not yet used ★

# 6/11 or 6/12 Split Row Airline Diagram

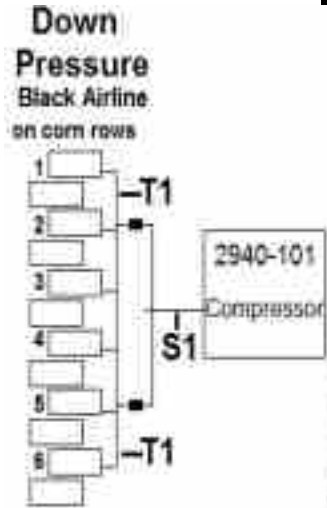

**KEY**

- = Dump Valve
- = Ball Valve
- = Planter Row Unit
- S1-2 = Supply Airline
- T1-4 = Trunk Airline

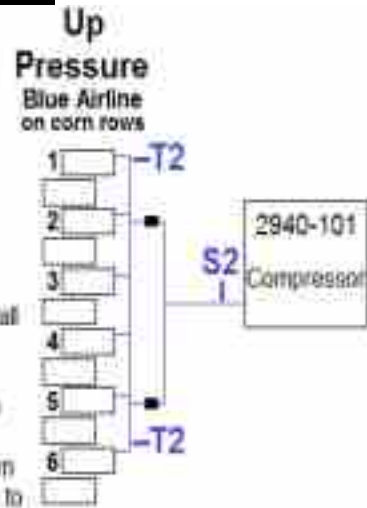

**Step 1: T1 & T2** Route black & blue airline from the first corn row to the last corn row. Install the black airline in the fitting of the down pressure (larger) air bag & the blue airline in the fitting of the up pressure (smaller) air bag on the last corn row. Trace both airlines back to the first corn row installing tees in each airline at each corn row. Route & install blue airline from the up pressure air bag fitting to the tee in the up pressure (blue) circuit for that corn row. Route & install black airline from the down pressure air bag fitting to the tee in the down pressure (black) circuit for that corn row. When back to the first corn row, cut each airline to length & install each airline into the fitting of the matching air bag.

**Step 2: S1** At the down pressure dump valve on corn rows 2 & 5, cut & install a tee into the T1 airline installed in step 1. Route & install black airline from the remaining open port in the tee to the outlet port of the down pressure dump valve & install. Route & install black airline from the RD port on the 2940-101 compressor housing to the nearest point on the frame that the seed units are mounted to and install a tee. Route and install black airline from each side of the tee to the inlet port of the dump valve on corn rows 2 & 5.

**Step 3: S2** At the up pressure dump valve on corn rows 2 & 5, cut & install a tee into the T2 airline installed in step 1. Route blue airline from the remaining open port in each tee to the outlet port of the dump valve & install. Route & install blue airline from the RU port on the 2940-101 compressor housing to the nearest point on the frame that the seed units are mounted to & install a tee. Route & install blue airline from each side of the tee to the inlet port of the dump valve on corn rows 2 & 5.

**Step 4: T3 & T4** Route black & blue airline from the first split row to the last split row. Install the black airline in the fitting of the down pressure (larger) air bag & the blue airline in the fitting of the up pressure (smaller) air bag on the last split row. Trace both airlines back to the first split row installing tees in each airline at each split row. Route & install blue airline from the up pressure air bag fitting to the tee in the up pressure (blue) circuit for that split row. Route & install black airline from the down pressure air bag fitting to the tee in the down pressure (black) circuit for that split row. When back to the first split row, cut each airline to length & install each airline into the fitting of the matching air bag.

**Step 5:** At the down pressure dump valve on corn rows 2 & 5, cut & install a tee into the T3 airline installed in step 4. At the up pressure dump valve on corn row 2 & 5, cut & install a tee into the T4 airline installed in step 4.

**Step 6:** Install a tee just downstream of the outlet port on the down pressure dump valve on corn rows 2 & 5. Install a 6 inch piece of black airline in the remaining part of each tee. Install a ball valve (2940-342) on the open end of each 6" piece of black airline. Route & install black airline from the open port on each ball valve to each tee in the T3 airline installed in step 5.

**Step 7:** Install a tee just downstream of the outlet port on the up pressure dump valve on corn rows 2 & 5. Install a 6 inch piece of blue airline in the remaining part of each tee. Install a ball valve on the open end of each 6" piece of blue airline. Route & install blue airline from the open port on each ball valve to each tee in the T4 airline installed in step 5.

**Step 8:** Install a plug (2940-352) provided in the spare fittings bag (2940-174) in the WT port on the 2940-101 compressor housing.

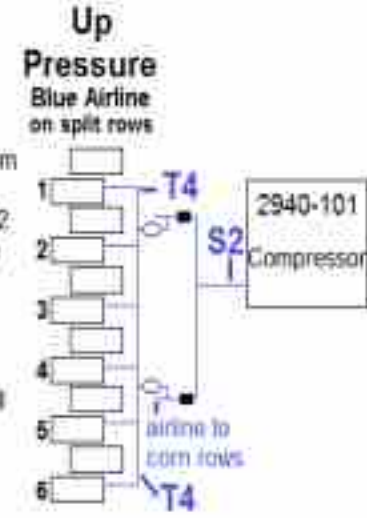
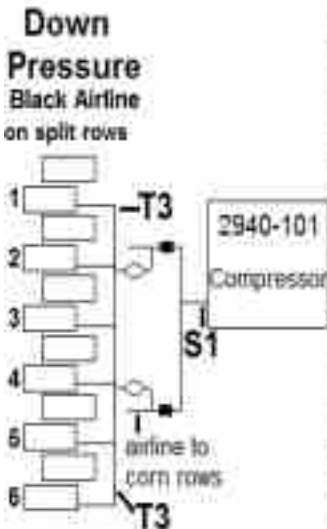

# 8 Row Dump Valve Diagram

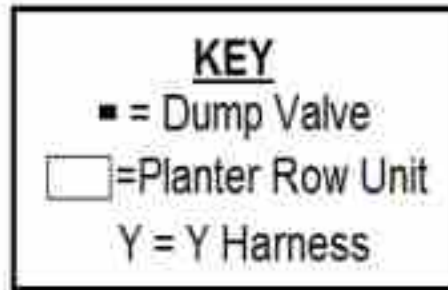

Down  
Pressure  
Dump Valve

Row

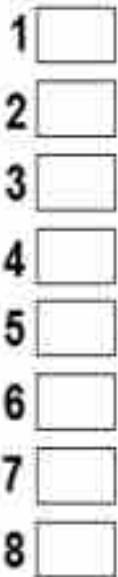

Routes to the 2  
pin pigtail  
labeled RM  
DOWN DUMP



Up  
Pressure  
Dump Valve

Row

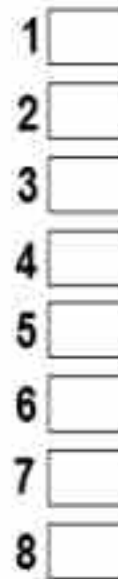

Routes to the 2 pin  
pigtail labeled RM  
UP DUMP



- Step 1:** Install 1 dump valve on row 4 & 1 dump valve on row 5.
- Step 2:** Install the male 12 pin Deutsch connector of the 2940-162 dump valve cable into the **GRAY** female connector on the 2940-101 compressor housing.
- Step 3:** Install the mating 2 pin connector of the 2940-156 black dump valve cable to the dump valve on row 5. Route the other end of the 2940-156 to the 2 pin connector labeled RM DOWN DUMP (orange/black wires) on the 2940-162 from step 2 & install.
- Step 4:** Install the mating 2 pin connector of the 2940-157 white dump valve cable to the dump valve on row 4. Route the other end of the 2940-157 to the 2 pin connector labeled RM UP DUMP (yellow/black wires) on the 2940-162 from step 2 & install.

**★ Aux 3 & Aux 4 on 2940-162 are not yet used ★**

# 8 Row Airline Diagram

**Down Pressure**  
**Black Airline**  
**Row**

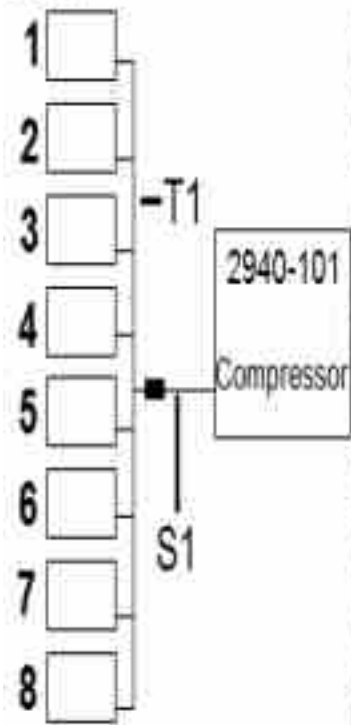

**Step 1:** T1 & T2 Route blue & black airline from row 1 to row 8. Install the black airline in the down pressure (larger) air bag & blue airline in the up pressure (smaller) air bag. Trace both airlines back to row 1 installing tees in each (blue and black) airline at each row unit. From each tee in the up pressure (blue airline) circuit, route blue airline to the up pressure air bag and install in the fitting. From each tee in the down pressure (black airline) circuit, route black airline to the down pressure air bag and install in the fitting. When back to row 1, cut each airline to length and install each airline to the matching air bag.

**Step 2:** On row 5 at the down pressure dump valve, install a tee in the black airline installed in step 1. Install black airline from the open port on the tee to the outlet port on the dump valve.

**Step 3:** On row 4 at the up pressure dump valve, install a tee in the blue airline installed in step 1. Install blue airline from the open port on the tee to the outlet port on the dump valve.

**Step 4:** S1 Route black airline from the RD port on the 2940-101 compressor housing to the inlet port on the down pressure dump valve on row 5 & install.

**Step 5:** S2 Route blue airline from the RU port on the 2940-101 compressor housing to the inlet port on the up pressure dump valve on row 4 & install.

**Step 6:** Install a plug (2940-352) into the WT port on the 2940-101 compressor housing to prevent air loss. Another way to do this is to cut a 6inch piece of black airline, install one end into the WT port, fold the airline over causing a kink, & zip tie the airline to stay like this. This circuit will not be used with this size of planter.

**Up Pressure**  
**Blue Airline**  
**Row**

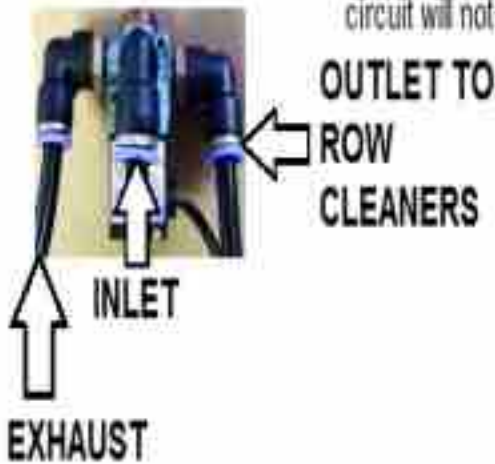
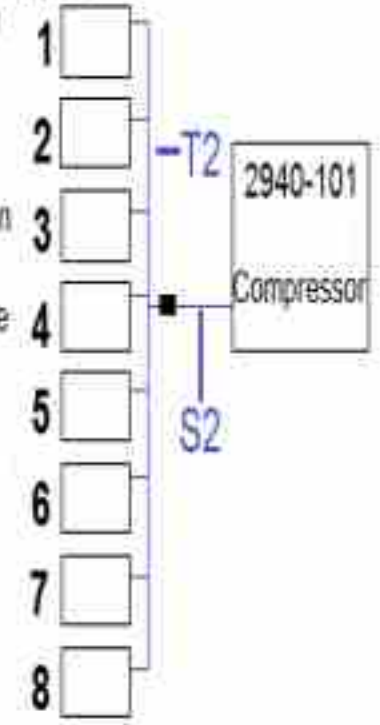

**KEY**

- = Dump Valve
- = Planter Row Unit
- T1-2 = Trunk Line
- S1-2 = Supply Line





# 8/15 or 8/16 Split Row Dump Valve Diagram

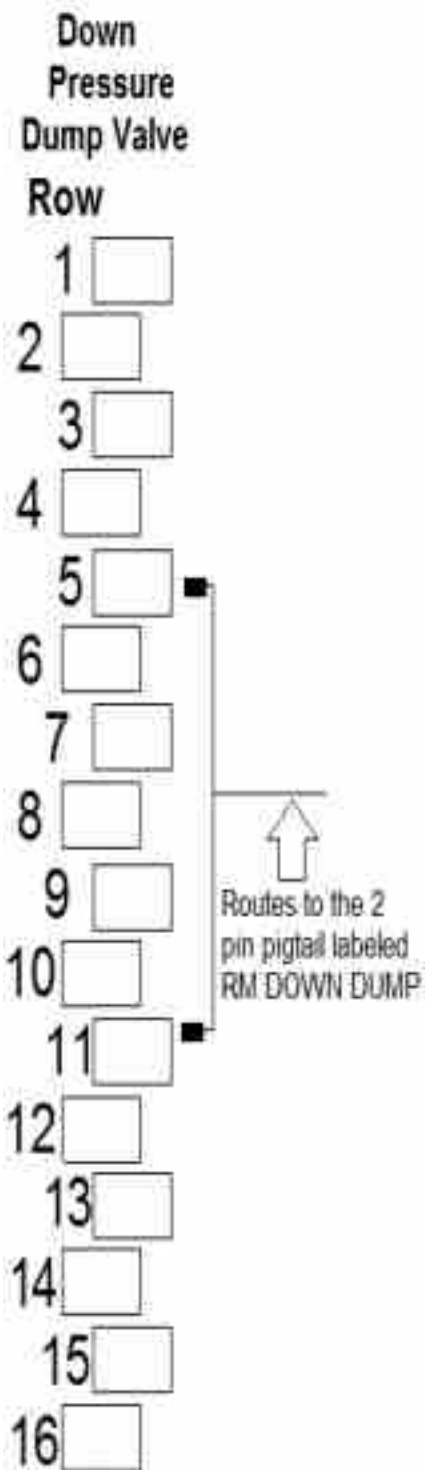
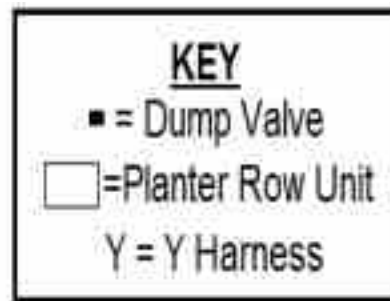

**Step 1:** Install 2 dump valves on each of the following rows: 5 & 11.

**Step 2:** Install the male 12 pin Deutsch connector of the 2940-162 dump valve cable into the **GRAY** female connector on the side of the 2940-101 compressor housing.

**Step 3:** Route & install 15 foot length of black dump valve cable (2940-156) from the 2 pin connector of 1 dump valve on row 5 to 1 dump valve on row 11. Use a black "Y" harness (2940-158) to connect the down pressure dump valve on row 11 to the 15 foot black dump valve cable routed from row 5's down pressure dump valve. From the remaining open connector on the black "Y" harness, route the necessary length of black dump valve cable to reach the 2 pin connector labeled RM DOWN DUMP (orange/black wires) on the 2940-162 harness installed in step 2.

**Step 4:** Route & install 15 foot length of white dump valve cable (2940-157) from the open 2 pin connector of the up pressure dump valve on row 5 to the up pressure dump valve on row 11. Use a white "Y" harness (2940-159) to connect the up pressure dump valve on row 11 to the 15 foot white dump valve cable routed from row 5. From the remaining open connector on the white "Y" harness, route the necessary length of white dump valve cable to reach the 2 pin connector labeled RM UP DUMP (yellow/black wires) on the 2940-162 harness installed in step 2.

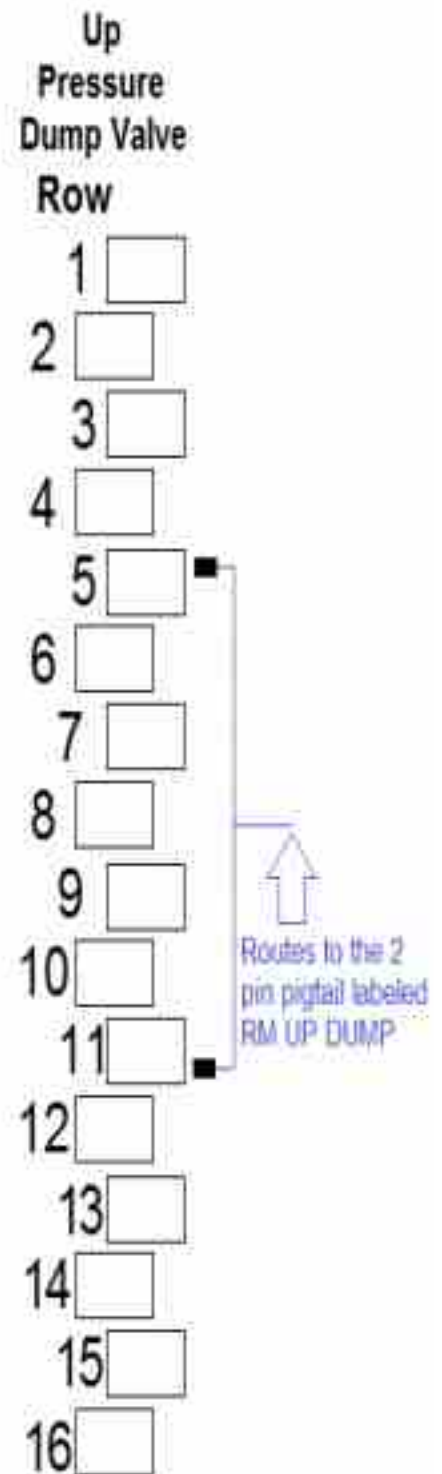

★ Aux 3 & Aux 4 on 2940-162 are not yet used ★

# 8/15 or 8/16 Split Row Airline Diagram

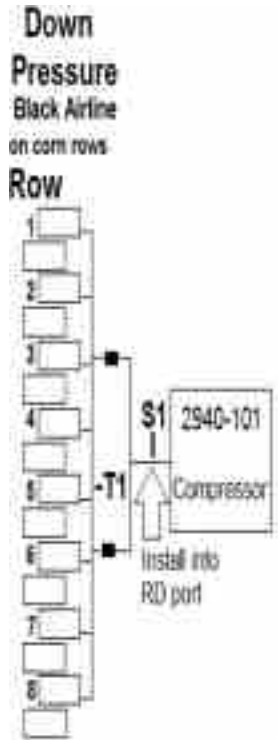

**KEY**

■ = Dump Valve

□ = Planter Row Unit

○ = Ball Valve

T1-4 = Trunk Line

S1-2 = Supply Line

**Step 1: T1 & T2** Route black & blue airline from the first corn row to the last corn row. Install the black airline in the fitting of the down pressure (larger) air bag & the blue airline in the fitting of the up pressure (smaller) air bag on the last corn row. Trace both airlines back to the first corn row installing tees in each airline at each corn row. Route & install blue airline from the up pressure air bag fitting to the tee in the up pressure (blue) circuit for that corn row. Route & install black airline from the down pressure air bag fitting to the tee in the down pressure (black) circuit for that corn row. When back to the first corn row, cut each airline to length & install each airline into the fitting of the matching air bag.

**Step 2: S1** At the down pressure dump valve on corn rows 3 & 6, cut & install a tee into the T1 airline installed in step 1. Route & install black airline from the remaining open port in the tee to the outlet port of the down pressure dump valve & install. Route & install black airline from the RD port on the 2940-101 compressor housing to the nearest point on the frame that the seed units are mounted to and install a tee. Route & install black airline from each side of the tee to the inlet port of the dump valve on corn rows 3 & 6.

**Step 3: S2** At the up pressure dump valve on corn rows 3 & 6, cut & install a tee into the T2 airline installed in step 1. Route blue airline from the remaining open port in each tee to the outlet port of the dump valve & install. Route & install blue airline from the RD port on the 2940-101 compressor housing to the nearest point on the frame that the seed units are mounted to & install a tee. Route & install blue airline from each side of the tee to the inlet port of the dump valve on corn rows 3 & 6.

**Step 4: T3 & T4** Route black & blue airline from the first split row to the last split row. Install the black airline in the fitting of the down pressure (larger) air bag & the blue airline in the fitting of the up pressure (smaller) air bag on the last split row. Trace both airlines back to the first split row installing tees in each airline at each split row. Route & install blue airline from the up pressure air bag fitting to the tee in the up pressure (blue) circuit for that split row. Route & install black airline from the down pressure air bag fitting to the tee in the down pressure (black) circuit for that split row. When back to the first split row, cut each airline to length & install each airline into the fitting of the matching air bag.

**Step 5:** At the down pressure dump valve on corn rows 3 & 6, cut & install a tee into the T3 airline installed in step 4. At the up pressure dump valve on corn row 3 & 6, cut & install a tee into the T4 airline installed in step 4.

**Step 6:** Install a tee just downstream of the outlet port on the down pressure dump valve on corn rows 3 & 6. Install a 6 inch piece of black airline in the remaining port of each tee. Install a ball valve (2940-342) on the open end of each 6 inch piece of black airline. Route & install black airline from the open port on each ball valve to each tee in the T3 airline installed in step 5.

**Step 7:** Install a tee just downstream of the outlet port on the up pressure dump valve on corn rows 3 & 6. Install a 6 inch piece of blue airline in the remaining port of each tee. Install a ball valve on the open end of each 6 inch piece blue airline. Route & install blue airline from the open port on each ball valve to each tee in the T4 airline installed in step 5.

**Step 8:** Install a plug (2940-352) provided in the spare fittings bag (2940-174) in the WT port on the 2940-101 compressor housing.

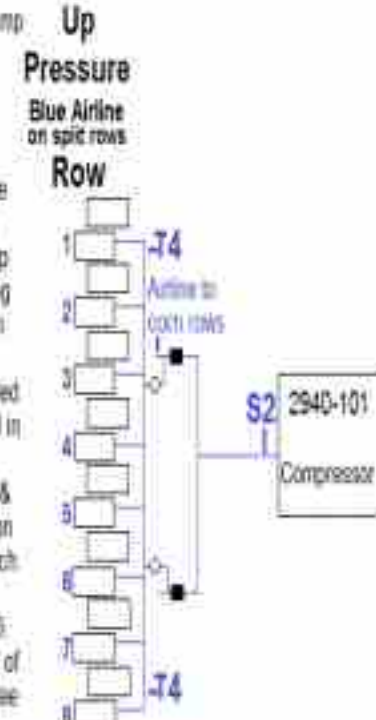
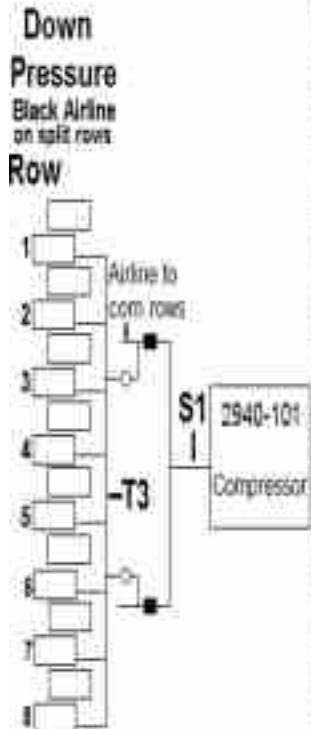
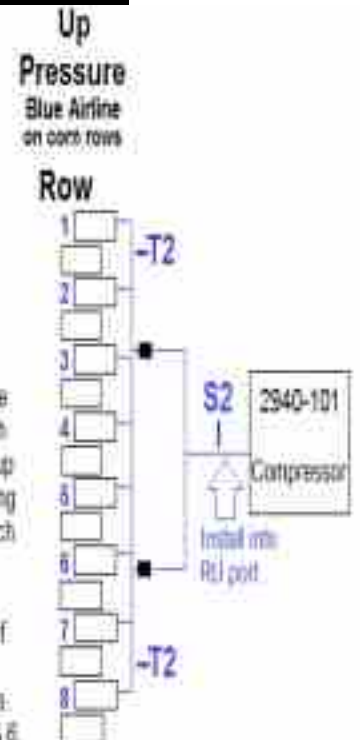

# 12 Row Dump Valve Diagram

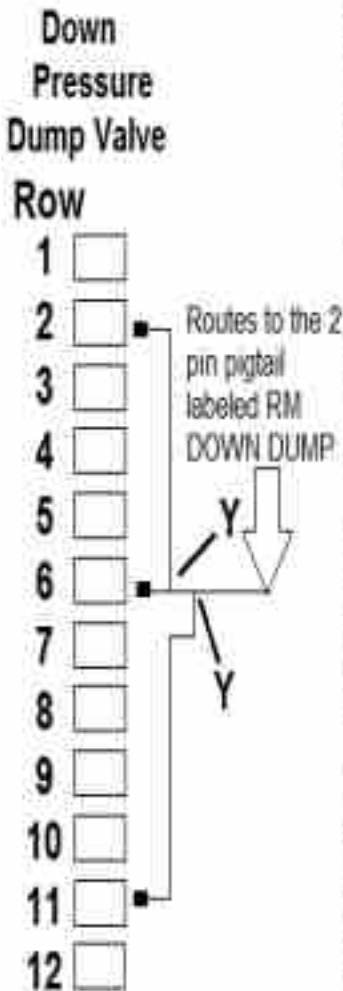
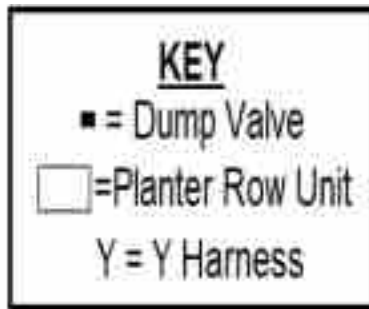

**Step 1:** Install 2 dump valves on each of the following rows: 2, 6, & 11.

**Step 2:** Install the male 12 pin Deutsch connector of the 2940-162 dump valve cable into the **GRAY** female connector on the side of the 2940-101 compressor housing.

**Step 3:** At row 2, install the mating 2 pin connector on the 2940-156 15ft black dump valve cable to the 2 pin cable on one dump valve and install the mating 2 pin connector on the 2940-157 15ft white dump valve cable to the 2 pin cable on the other dump valve. Route both cables to the dump valves on row 6 but do not install.

**Step 4:** At row 11, install the mating 2 pin connector on the 2940-156 15ft black dump valve cable to the 2 pin cable on one dump valve and install the mating 2 pin connector on the 2940-157 15ft white dump valve cable to the 2 pin cable on the other dump valve. Route both cables to the dump valves on row 6 but do not install.

**Step 5:** At row 6, install a 2940-158 black Y harness connecting the black dump valve cables routed in steps 3 & 4.

**Step 6:** Install a second black Y harness connecting one dump valve on row 6 to the Y harness installed in step 5.

**Step 7:** Route the appropriate length of black dump valve cable(s) from the open 2 pin connector at row 6 (from step 6) to the 2 pin connector labeled RM DOWN DUMP (orange/black wires) on the 2940-162 from step 2.

**Step 8:** At row 6, install a 2940-159 white Y harness connecting the white dump valve cables routed in steps 3 & 4.

**Step 9:** Install a second white Y harness connecting the open dump valve on row 6 to the Y harness installed in step 8.

**Step 10:** Route appropriate length of white dump valve cable(s) from the open 2 pin connector at row 6 (from step 9) to the 2 pin connector labeled RM UP DUMP (yellow/black wires) on the 2940-162 from step 2.

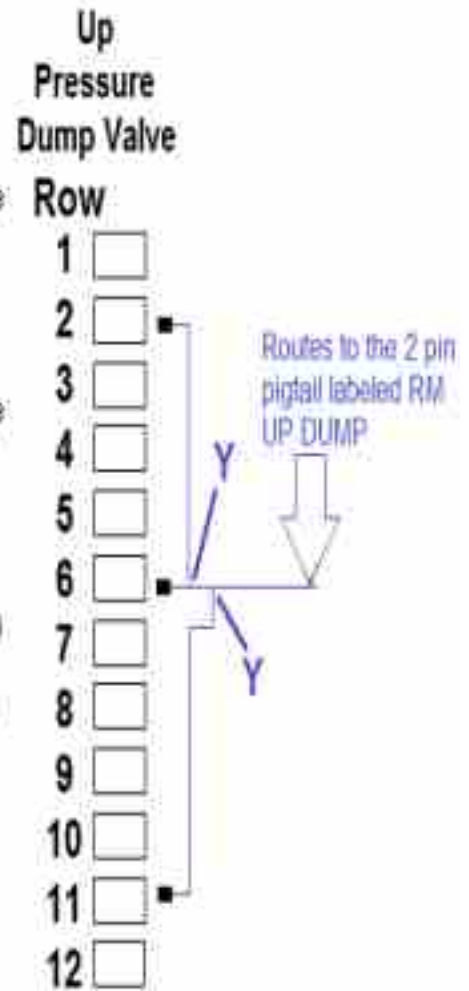

★ Aux 3 & Aux 4 on 2940-162 are not yet used ★

# 12 Row Airline Diagram

**Step 1: T1 & T2** Route blue & black airline from row 1 to row 4. At row 4, install the black airline in the down pressure (larger) air bag fitting & blue airline in the up pressure (smaller) air bag fitting. Install a tee in each color of airline at rows 2 & 3. Install blue airline from the up pressure air bag to the tee in the blue airline & install black airline from the down pressure air bag to the tee in the black airline at each row. At row 1, cut both airlines to length & install each airline into the matching air bag fitting.

**Step 2:** Cut & tee T1 & T2 airline next to the matching dump valve on row 2. Route black airline from the tee in the T1 black airline into the outlet port of the down pressure dump valve (black cable) and route blue airline from the tee in the T2 blue airline to the outlet port of the up pressure dump valve (white cable)

**Step 3: T5 & T6** Route blue and black airline from row 12 to row 9. At row 9, install each airline into the matching air bag's fitting. Install a tee in each color of airline at row 10 & 11. Install blue airline from the up pressure air bag fitting to the tee in the blue airline & black airline from the down pressure air bag fitting to the tee in the black airline at each row. At row 12, cut both airlines to length & install each airline into the matching air bag fitting.

**Step 4:** Cut & tee T5 & T6 airline next to the matching dump valve on row 11. Route black airline from the tee in the T5 black airline into the outlet port of the down pressure dump valve (black cable) and route blue airline from the tee in the T6 blue airline to the outlet port of the up pressure dump valve (white cable).

**Step 5: T3 & T4** Route blue and black airline from row 5 to row 8. Install each airline at row 8 into the matching air bag's fitting. Trace both airlines back to row 5 installing a tee in each airline at rows 6 & 7. Install blue airline from the up pressure air bag fitting to the tee in blue airline on rows 6 & 7. Install black airline from the down pressure air bag fitting to the tee in the black airline on rows 6 & 7. At row 5, cut both airlines to length & install into the matching air bag.

**Step 6:** Cut & tee the T3 & T4 airline next to the matching dump valve on row 6. Route & install black airline from the tee in T3 black airline into the outlet port of the down pressure dump valve on row 6 & route blue airline from the tee in the T4 blue airline to the outlet port of the up pressure dump valve on row 6.

**Step 7: S1** Route black airline from RD port of the 2940-101 compressor housing to the nearest point on the main frame that the seed units are mounted to & install a tee. From each side of the tee, route black airline to the inlet port on the down pressure dump valve on each wing/side of the planter. (Rows 2 and 11) (follow the same routing path as the trunk lines)

**Step 8: S2** Route blue airline from the RU port of the 2940-101 compressor housing to the nearest point on the main frame that the seed units are mounted to and install a tee. Install a 6 inch piece of blue line into one port of tee. Install a second tee on the open end of the 6 inch piece of blue airline. This will give you 3 open ports on this circuit to use. Route blue airline from 2 of those ports to each inlet port on the up pressure dump valve on the wings/sides of the planter on row 2 and row 11 & install. Route blue airline from remaining port of the tee to the inlet port on the up pressure dump valve on row 6 & install.

**Step 9: S3** Route black airline from the WT port of the 2940-101 compressor housing to the inlet port of the down pressure dump valve on row 6.

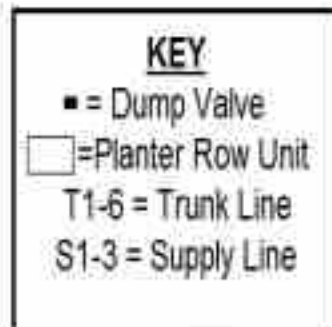
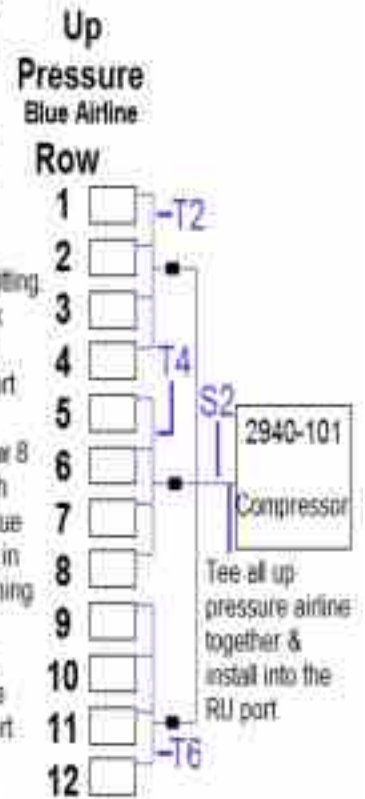
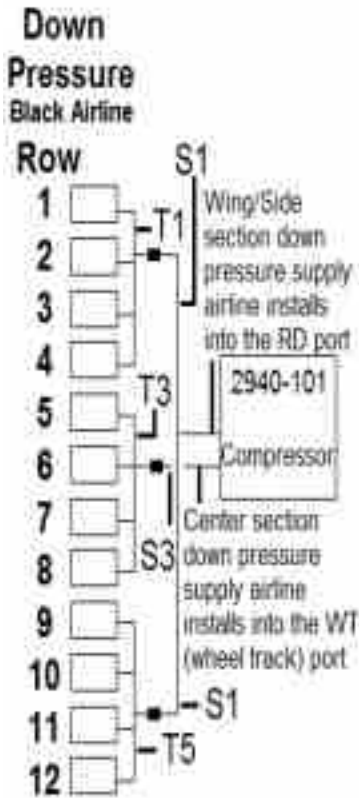

# 16 Row Dump Valve Diagram

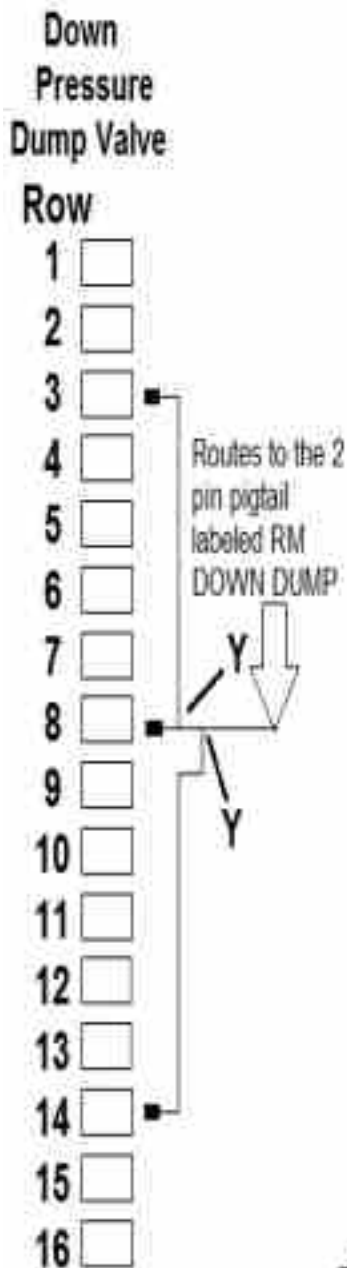
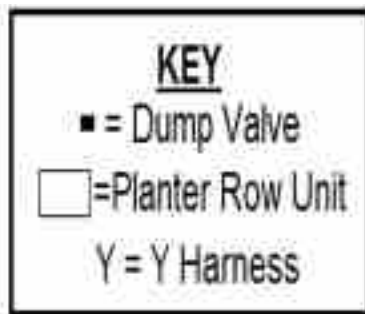

**Step 1:** Install 2 dump valves on each of the following rows: 3, 8, & 14.

**Step 2:** Install the male 12 pin Deutsch connector of the 2940-162 dump valve cable into the **GRAY** female connector on the side of the 2940-101 compressor housing.

**Step 3:** At row 3, install the mating 2 pin connector on the 2940-156 15ft black dump valve cable to the 2 pin cable on one dump valve and install the mating 2 pin connector on the 2940-157 15ft white dump valve cable to the 2 pin cable on the other dump valve. Route both cables to the dump valves on row 8 but do not install.

**Step 4:** At row 14, install the mating 2 pin connector on the 2940-156 15ft black dump valve cable to the 2 pin cable on one dump valve and install the mating 2 pin connector on the 2940-157 15ft white dump valve cable to the 2 pin cable on the other dump valve. Route both cables to the dump valves on row 8 but do not install.

**Step 5:** At row 8, install a 2940-158 black Y harness connecting the black dump valve cables routed in steps 3 & 4.

**Step 6:** Install a second black Y harness connecting one dump valve on row 8 to the Y harness installed in step 5.

**Step 7:** Route the appropriate length of black dump valve cable(s) from the open 2 pin connector at row 6 (from step 6) to the 2 pin connector labeled RM DOWN DUMP (orange/black wires) on the 2940-162 from step 2.

**Step 8:** At row 8, install a 2940-159 white Y harness connecting the white dump valve cables routed in steps 3 & 4.

**Step 9:** Install a second white Y harness connecting the open dump valve on row 8 to the Y harness installed in step 8.

**Step 10:** Route appropriate length of white dump valve cable(s) from the open 2 pin connector at row 6 (from step 9) to the 2 pin connector labeled RM UP DUMP (yellow/black wires) on the 2940-162 from step 2.

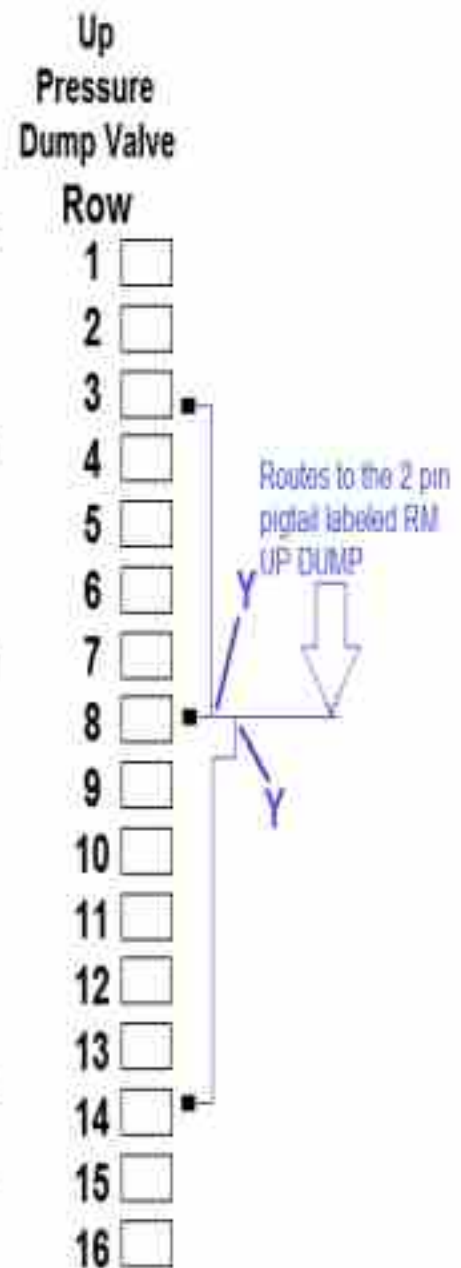

★ Aux 3 & Aux 4 on 2940-162 are not yet used ★

# 16 Row Airline Diagram

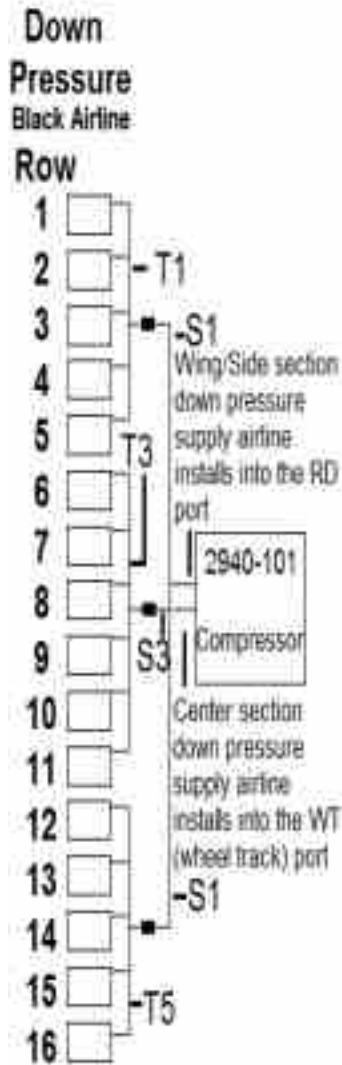

**Step 1: T1 & T2** Route blue & black airline from row 1 to row 5. At row 5, install the black airline in the down pressure (larger) air bag fitting & blue airline in the up pressure (smaller) air bag fitting. Install a tee in each color of airline at rows 2-4. Install blue airline from the up pressure air bag to the tee in the blue airline & install black airline from the down pressure air bag to the tee in the black airline. At row 1, cut both airlines to length & install each airline into the matching air bag fitting.

**Step 2:** Cut & tee the T1 & T2 airline next to the matching dump valve on row 3. Route black airline from the tee in the T1 black airline into the outlet port of the down pressure dump valve (black cable) and route blue airline from the tee in the T2 blue airline to the outlet port of the up pressure dump valve (white cable).

**Step 3: T5 & T6** Route blue and black airline from row 16 to row 5. At row 5, install each airline into the matching air bag's fitting. Install a tee in each color of airline at rows 13-15. Install blue airline from the up pressure air bag fitting to the tee in the blue airline & black airline from the down pressure air bag fitting to the tee in the black airline. At row 12, cut both airlines to length and install each airline into the matching air bag fitting.

**Step 4:** Cut & tee T5 & T6 airline next to the matching dump valve on row 14. Route black airline from the tee in the T5 black airline into the outlet port of the down pressure dump valve (black cable) and route blue airline from the tee in the T6 blue airline to the outlet port of the up pressure dump valve (white cable).

**Step 5: T3 & T4** Route blue and black airline from row 6 to row 11. Install each airline at row 11 into the matching air bag's fitting. Trace both airlines back to row 6 installing a tee in each airline at each row (rows 5-8). Install blue airline from the up pressure air bag fitting to the tee in blue airline on rows 7-10. Install black airline from the down pressure air bag fitting to the tee in the black airline on rows 7-10. At row 6, cut both airlines to length and install into the matching air bag.

**Step 6:** Cut & tee the T3 & T4 airline next to the matching dump valve on row 8. Route & install black airline from the tee in T3 black airline into the outlet port of the down pressure dump valve on row 8 & route blue airline from the tee in the T4 blue airline to the outlet port of the up pressure dump valve on row 8.

**Step 7: S1** Route black airline from RD port of the 2940-101 compressor housing to the nearest point on the main frame that the seed units are mounted to & install a tee. From each side of the tee, route & install black airline to the inlet port on the down pressure dump valve on each wing/side of the planter. (Rows 3 and 14) (follow the same routing path as the trunk airlines)

**Step 8: S2** Route blue airline from the RU port of the 2940-101 compressor housing to the nearest point on the main frame that the seed units are mounted to and install a tee. Install a 6 inch piece of blue line into one part of tee. Install a second tee on the open end 6 inch piece of blue airline. This will give you 3 open parts on this circuit to use. Route blue airline from 2 of those parts to each inlet port on the up pressure dump valve on the wingsides of the planter on row 3 and row 14 & install. Route blue airline from remaining part of the tee to the inlet port on the up pressure dump valve on row 8 & install.

**Step 9: S3** Route black airline from the WT port of the 2940-101 compressor housing to the inlet port of the down pressure dump valve on row 8.

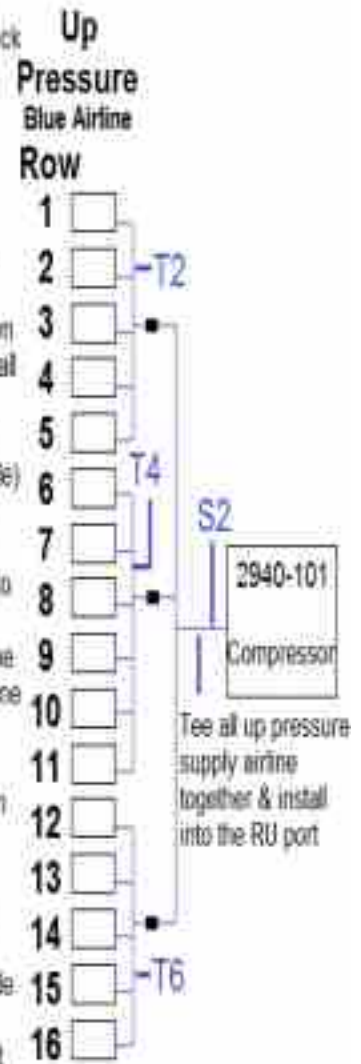

# Cab Controller Operation

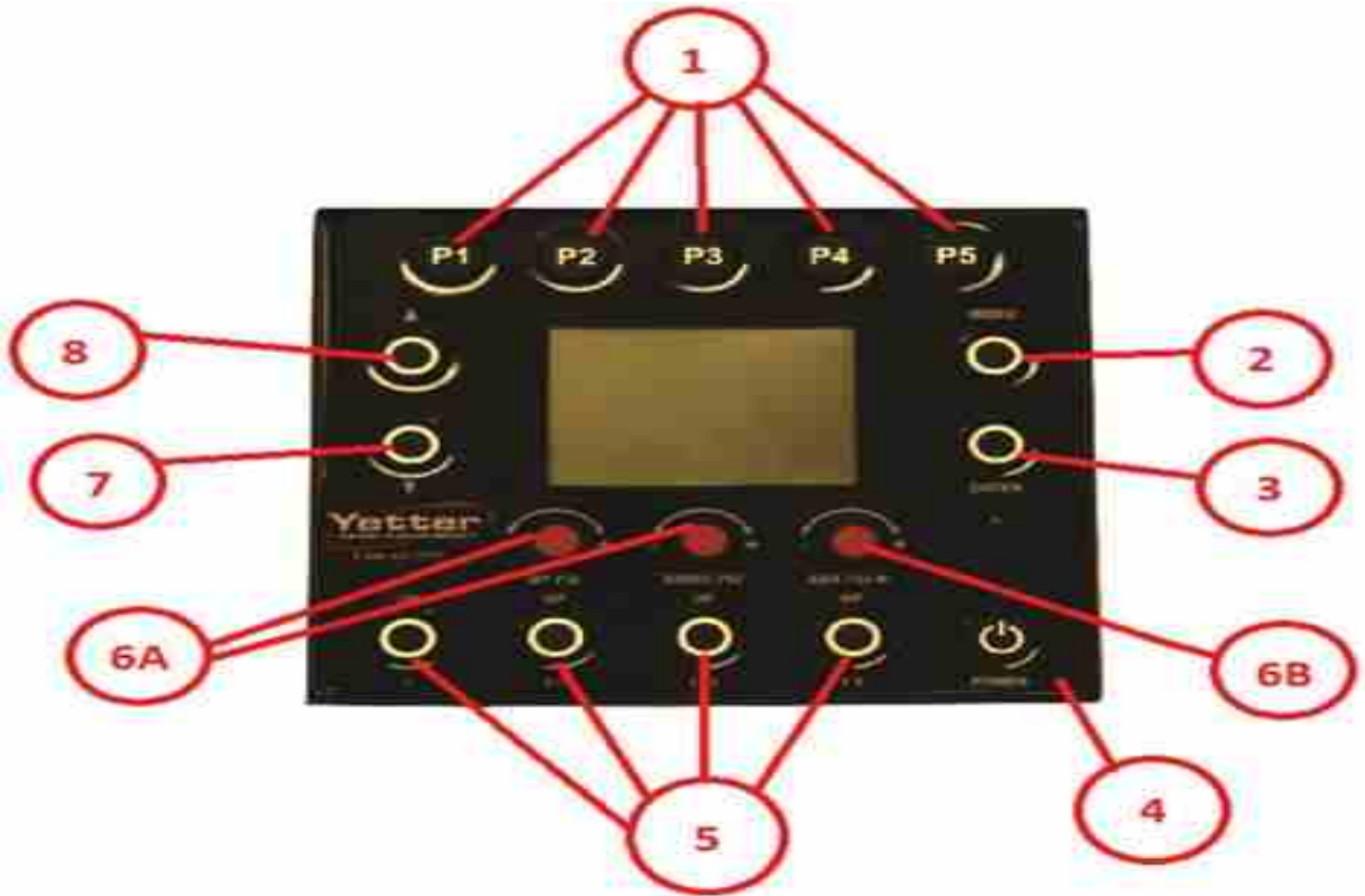

1. **PRESET 1 – 5** - Hold (approximately 5 seconds) to save & store the current pressure settings to the desired preset.
2. **MENU**- Press to display Menu Options. If in Menu Options, pressing Menu will take operator back one screen and eventually to operating screen.
3. **ENTER**- Press to activate/deactivate the system, also used in Menu options to make selections.
4. **POWER**- Press and hold (approximately 7 seconds) to turn ON/OFF the 2940-100 Cab Controller Display.
5. **UP I-IV**- Press I to raise all row cleaners max travel. Pressing again lowers all row cleaners to preset setting. **Up II-IV are not used!**
6. **A** **PSI UP Encoder(RU)** - rotate to INCREASE/DECREASE Air Pressure on the attachment.  
**PSI DOWN Encoder (RD)** - Rotate to INCREASE/DECREASE Air Pressure on the attachment.
6. **B** **PSI Aux Encoder (WT, A1, A2, A3)** - Push to scroll the cursor. ROTATE to INCREASE/DECREASE air pressure on the cursor selected circuit. (WT, A1, A2, and A3) WT circuit is the only circuit used. A1, A2, & A3 are not utilized at this time.
7. Push to scroll DOWN in the MENU display. Hold this down for 10 seconds to manually dump the water separator. Valve remains open for as long as button is pressed.
8. Push to scroll UP in the MENU display.

# 2940 Air Adjust Cab Controller Operation

## Screen Control and Navigation:

1. **Screen Navigation:** Unless otherwise noted the MENU button will always take you back one screen at a time until you are arrive at the main menu.
2. To navigate to other screens from the main menu use the scroll arrow buttons to select the page you would like to go to and then press ENTER to navigate there.
3. **Splash Screen (Screen 0):** This screen will be presented after the POWER button has been pressed. This screen will show the project number and software V/R. It will be displayed for 5 seconds. After that the system will navigate to screen 1.
4. **Main Operating Screen (Screen 1, Pictured below):** This screen is where the air system is monitored and controlled.

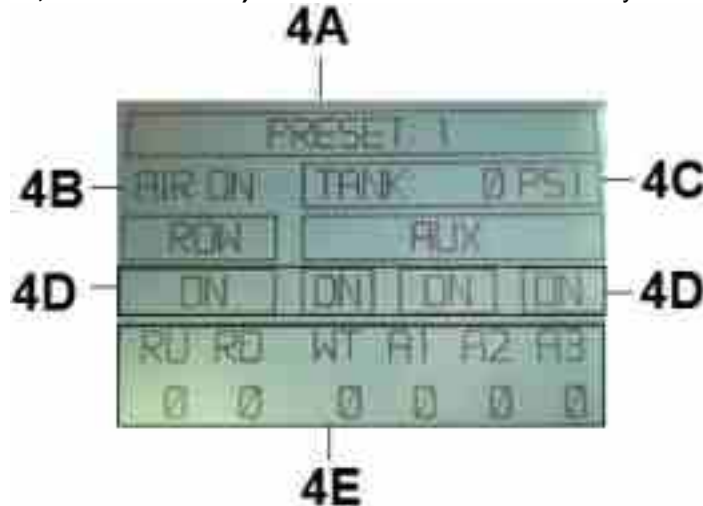

- 4A** The top of the screen shows what preset you are currently using (1-5), if a manual adjustment is made it will display "PRESET (X) MANUAL" until the preset is saved, then it will display PRESET X.
- 4B** This will display "AIR ON" or "AIR OFF" depending on the status of the air system. Pressing ENTER will activate or deactivate the AIR ON/OFF. "AIR ON" signifies that the air system is operational & supplying air to the attachment. If AIR ON is displayed with sufficient tank pressure & there is no air in the air bag of the attachment, check the 40A breaker at the battery.
- 4C** There is a field which will display the tank pressure in psi "TANK PSI".
- 4D** There are (4) fields which will indicate "UP" or "DN" (DOWN) depending on the state of the dump valves that are being controlled. If the Roman Numeral I indicator light is on, UP (under ROW) will be displayed & all residue managers will be in the up position. The UP/DN function under AUX & Roman Numerals II, III, & IV are not used.
- 4E** There are (6) fields which define the tools on the system and their pressures. The pressures shown at the bottom of this screen have two modes. In normal operation mode the real pressure feedback from the air system is shown, but if a manual adjustment is made it will show the commanded value for 7.5 seconds, after that delay it will return to displaying the feedback values. Yetter Electric Compressor systems only use RU, RD, & WT.

## Operation Settings:

### **"How much Down/Lift Pressure should I be running?"**

The amount of Down/Lift Pressure will vary greatly across soil types, tillage practices, soil moisture, row unit weight & many other variables. Manage the pressure in the down and/or lift circuits in order to maintain 90%+ Ground Contact while keeping the pressure between 20-60 psi. The cab controller will display the tank pressure in psi & the down/lift circuits in psi. A typical starting range for residue managers (RM) would be 35psi up, 30psi down, and 32psi WT. A typical starting range for RM/coulter combo would be 40psi up, 35 psi down, 37psi WT. When an ideal pressure setting is found for a certain field condition, press & hold a preset to store the desired setting. If the residue managers aren't removing enough residue, add more down pressure or subtract some up pressure. If the residue managers are being too aggressive, subtract down pressure or add up pressure.

### **Normal operating ranges:**

- Down Pressure Bags: 20-60psi
- Lift Pressure Bags: 20-60psi
- Tank Pressure: The tank pressure on the cab controller is the only way to know what the tank pressure is. The compressor will shut off around 95psi & start to recover around 85psi. The reading from the cab controller comes from the transducer (2940-441) & relays the psi to the VDM which communicates that pressure to the cab controller. If the tank pressure reads zero & you are sure there is tank pressure, a transducer needs ordered.



# 2940 Air Adjust Cab Controller Operation

**Main Menu:** This screen will allow you to navigate to the setup and service screens. Selecting EXIT will return you to the main operating screen.

**Setup:** Currently this screen has one option, to select & edit the Dump Valve Delay.

- **Dump Valve Delay:** This screen allows you to adjust the dump valve delay time. Press the ENTER button to go into the edit mode & then adjust the time with the SCROLL UP/DOWN buttons. The time value will have .25 second resolution & will be adjustable from 0-60 seconds. Pressing ENTER again will exit the edit mode. Generally, no more than 2.5 seconds is needed. **(see page 44 for proper setting)**
- **Setting the Dump Valve Delay:**
  - Ensure all dump valves & harnesses are plugged in securely & that dump valves are functioning properly
  - Adjustments will be made in increments of .25 seconds.
  - When the dump valve delay is properly set, the residue managers should react as follows: with sufficient tank pressure, AIR ON displayed, command RU to 30psi, RD to 35psi, & WT to 37psi. Press the Roman numeral I button & all residue managers will raise. Press the Roman numeral I button again & all residue managers should drop to half travel & then settle into position. If the residue managers don't go to half travel, more dump valve delay is needed. If the residue managers go further than half travel, less dump valve delay is needed. It is best to have a second person looking as well.
  - Access the dump valve delay screen on your cab controller.
  - Adjust the dump valve delay by .25 seconds at a time in the desired direction (more or less), revert to home screen.
  - Press the Roman numeral I button & observe residue managers to see if more adjustment is needed.
  - Keep adjusting as needed

**SEE PAGE 44 TO SEE WHAT SETTING THE DUMP VALVE DELAY SHOULD BE FOR YOUR SITUATION**

**Service:** This screen has (3) selections to choose from, HOUR METERS, MAINTENANCE, and FAULT STATUS.

- **Hour Meters:** This screen will contain (2) hour meters, air compressor hours, which only increments if the compressor is on, & total system hours, which only increments if the air system is enabled (AIR ON). There will also be a field that shows duty cycle; this is a cumulative value calculated by dividing compressor hours by system hours which equals the percentage of time the compressor has run in reference to how many hours the system has been enabled. The percentage shown by the duty cycle should be less than 20%. **If not, perform the leak check. (See pages 44)**
- **Maintenance:** This screen is static & has a text description indicating basic maintenance info.
- **Fault Status: J1:** This screen contains real time read outs of command & feedback voltage readings for each pin present in the connector labeled J1.
- **Fault Status: J2:** This screen contains real time read outs of command & feedback voltage readings for each pin present in the connector labeled J2
- **Fault Status: J3:** This screen contains real time read outs of command & feedback voltage readings for each pin present in the connector labeled J3
- **Fault Status: J4:** This screen contains real time read outs of command & feedback voltage readings for each pin present in the connector labeled J4

**Warning – Compressor Run Time:** This screen will be displayed if the compressor has been running continuously for 15 minutes. **Evaluate the system for leaks or other issues before continuing.** When all issues are fixed, press ENTER to clear the screen & resume normal operation.

**Warning – Check Fault Screens:** If a fault is detected, this screen will be displayed. Contact a service representative at Yetter, & have the fault screens ready, to review voltage readouts for diagnostics. This warning will remain displayed until the ENTER button is pressed.

**Air System On:** The state of this displayed text tells the operator if the system is operating or not. The Air System will be ON if the ENTER button is pressed on the main operating screen (screen 1). At this point the indicator will turn from red to green. It will maintain ON until ENTER is pressed again, turning the indicator back to its original color. Remember to switch the air system off, before removing power to the controller. The system is ON when the indicator is green; also the text on the screen will read "AIR ON" (vs. "AIR OFF").

**Compressor Sump Dump:** This dumps any water that has built up in the compressor tank or water separator. This function is programmed to open the valve for 5 seconds every hour to dump the moisture. The Compressor Sump Dump valve can also be activated by holding the "Scroll Down" button while on the Main Operating Screen for 8 seconds. The valve will remain open as long as the button is pressed, releasing the button will close the valve.

# 2940 Air Adjust Cab Controller Operation

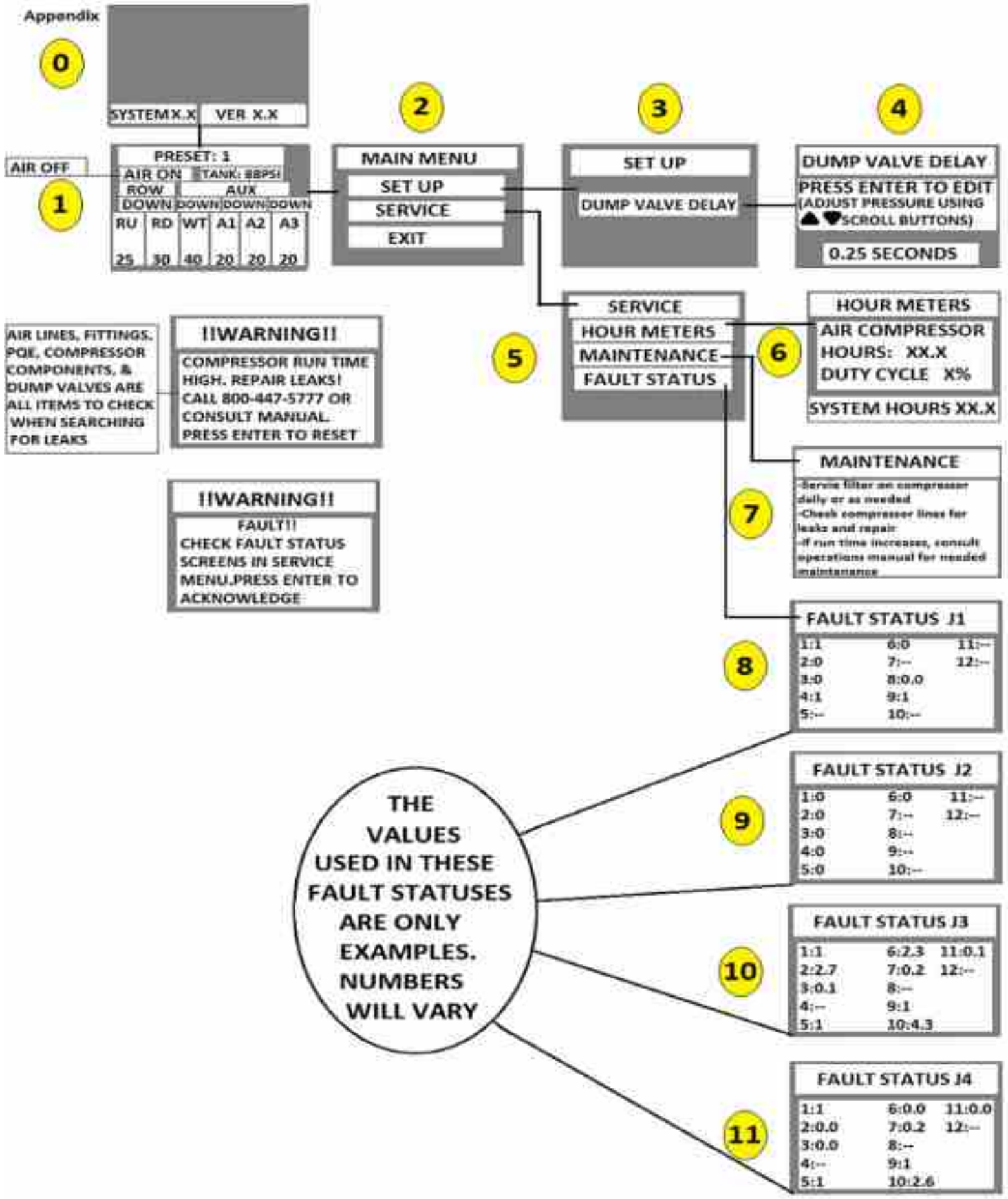

# 2940 Operation Guide

## System Start Up Procedure

Below is the 2940 system startup procedure that should be followed every time the 2940-100 Cab Controller is turned on. This will ensure that component parts of the system are working correctly.

If this is the first start up procedure after installation, make sure to set the dump valve delay and familiarize yourself with cab controller operation. Before activating the system, save P1 at 35 RU, 30 RD, & 32 WT. Save P2 at 35 RU, 33 RD, & 35 WT.

**Step 1:** Supply power to the cab controller (start the tractor) & hold the Power button until the cab controller turns on.

**Step 2:** Turn all pressures (RU, RD, & WT) to 0psi.

**Step 3:** Press Enter to activate the system. AIR: ON will be displayed. The Yetter compressor will turn on (if it is below 85psi) & should build to 95psi & shut off. If the Yetter compressor doesn't run & is below 80psi, check the 40A & 80 amp breaker on the tractor battery. Trip the breakers and reset the breaker arm firmly back into the pocket.

**Step 4:** When the compressor has shut off, press a preset (P1 – P5) to apply air to the air bags of the residue managers.

**Step 5:** Press the UP I button (lowest left button) while watching all the residue managers. When this button is pressed and the indicator light next to UP is lit, the residue managers should all raise.

**Step 6:** Press the UP 1 button while watching all the residue managers. All the residue managers should drop to half travel and then settle into position. (change dump valve delay if necessary, [see page 44](#))

## ROW CLEANER DO'S AND DON'TS

1. **DO NOT** use as a tillage tool; Residue Managers are designed to move crop residue & to break up clods & crust.
2. **DO NOT** operate planter at slow speeds. Ground speed affects how aggressive the residue manager wheels are. Operate at sufficient speed (refer to you OEM planter manufacturer manual) to maintain good residue flow.
3. **DO NOT** expect 100% of crop residue to be cleared, it is not necessary and would necessitate engaging the soil. The width of path cleared depends on ground conditions, depth setting, and ground speed.
4. **DO** expect to see wheels occasionally quit turning, indicating ideal (shallow) setting which is not moving soil.
5. **DO** adjust toolbar frame height 20"-22" and drawbar correctly. It is very important to ensure planter opener will follow ground contours properly. [See Page 43 for the planter levelness and height.](#)
6. **DO NOT** run air pressure below 20psi or above 60psi. Full range of travel can be achieved between these settings.
7. **DO** grease the hub cavity of the bearings regularly. Even though the bearings are sealed, filling the hub keeps moisture, dirt, & debris from entering the hub and ruining the seal. [See page 46 for greasing intervals.](#)
8. **DO NOT** run the coulter, if equipped, deeper than the disc opener blades. Coulter should be set to run even or slightly above disc opening blades depth.

**IMPORTANT:** For proper operation, the planter frame must operate level (fore, aft and side to side) and at the correct height, typically 20"-22". Regularly inspect the residue manager for loose or worn bolts & hardware. Repair or replace as needed.



### Overview:

This electronic control system works with a pneumatic system that controls pressure in the air bags as well as other air valves in the system on an agricultural application. The air bags provide independent up **AND** down pressure to the mechanical devices that are used on an agricultural implement.

### System Layout:

There are (2) main parts to the control system. The first being a VDM (Valve Drive Module), the role of the VDM is to provide Outputs to control functions of the pneumatic system. The VDM will also provide Inputs to monitor the pneumatic system as well as provide feedback to the operator. The second part is an in-cab switch panel/display (Cab Controller) that allows the operator to control the pneumatic system and monitor its performance.

# OPERATION PRECAUTIONS



## STOP

### MACHINE OPERATION

Read this before field operation of the Yetter product.

**IMPORTANT:** Failure to properly set the planter frame height & levelness can result in less than successful operation of the planter & the Yetter product. This may result in damaged equipment. All operators should read & thoroughly understand the instructions given prior to using the Yetter product.

**NOTE: DO NOT** use this product if the planter is not adjusted properly!

**Leveling the planter:** On a level planting surface, lower the planter frame to an operation height of **20"-22"**. Make adjustments to the planter as necessary. Read the planter operator's manual for recommended setting. Check to be sure the toolbar & row unit parallel arms are level fore & aft. Re-Check when the planter is in the field & has been fully loaded with seed, fertilizer, etc. Also, a field check with a bubble level on the frame should be made of the hitch height to ensure level operation front to back. It is important for the planter to operate level laterally. Tire pressure must be maintained at pressures specified by the manufacturer. Field & actual planting conditions change & will dictate planter frame heights. You must ensure that the row unit parallel arms are approximately parallel with the ground.

**IMPORTANT:** For proper operation of the planter attachments & row units, it is imperative that the planter toolbars and row unit parallel arms be level side-to-side & front-to-rear. The toolbar frame should operate at a 20"-22" height from the planting surface. Check the manufacturer's operator's manual for instructions on how to adjust the frame height & levelness. The decal below pertains to 2940 coulters combo units!

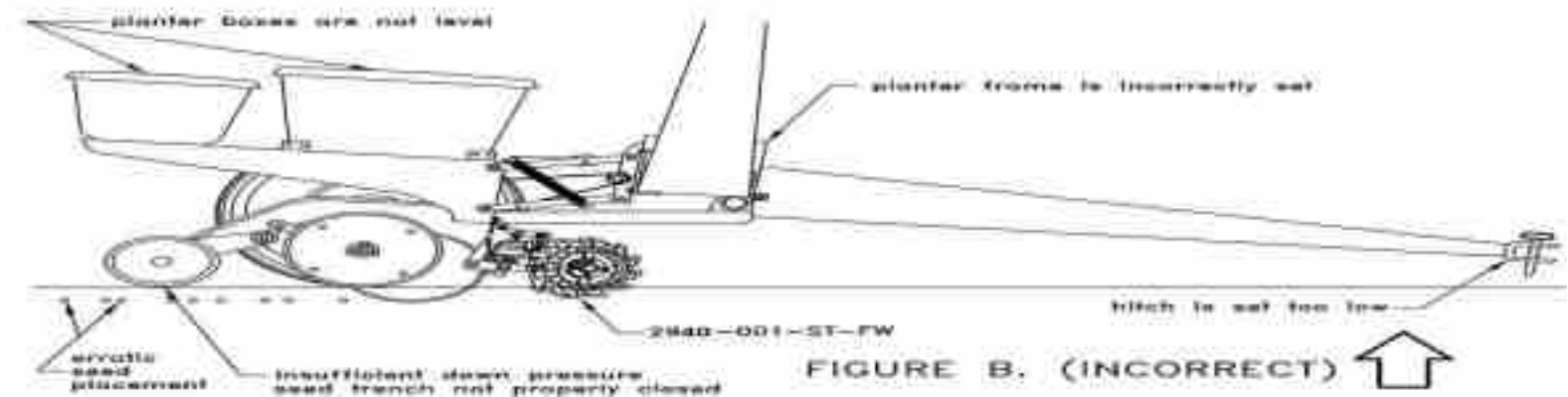
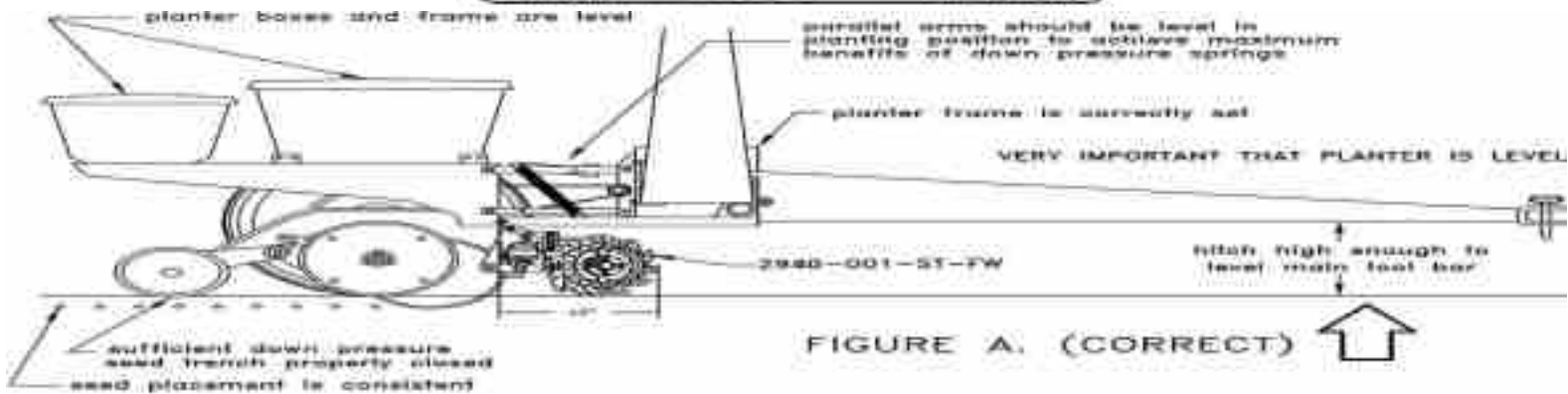

# Pre-Field Operation Guide

## **SYSTEM LEAK TESTING:**

A leak testing procedure should be performed after set-up of the 2940 Air Adjust system is complete. This procedure shall be performed at the beginning of each planting season and every 20 hours of in season use. **In addition, it should be performed if the user notices a lack of air pressure availability or if the compressor is running an abnormally high duty cycle or run time.** It will help keep the duty cycle in check, thus extending the life of the compressor. The most efficient way to perform a leak test is to use shop air, if available, to allow for a quieter environment to detect an air leak better. A 2940-382 shop air adaptor is provided in the 2940-174 spare fittings bag. The shop air adaptor is equipped with a shut off valve. Attach your matching male coupler to the open 1/4"NPT & install airline between the 3/8PTC fitting & the water separator inlet port. Wrap the male threads of the shop air fitting with Teflon tape.



- Step 1:** Power the cab controller, turn all pressures (RU, RD, and WT) to 0psi, and press ENTER to activate the system. Make sure the Yetter Electric Compressor has operated correctly, has built around 145psi, & shut off.
- Step 2:** Check the compressor, water separator assembly, and all compressor housing components for leaks. Start a stopwatch & after 5 Minutes, note the tank pressure. If the tank pressure drops more than 2psi, there is a leak. Repair as needed.
- Step 3:** Turn up pressure (RU) to 30psi, exit the tractor cab, & start at the compressor housing checking all blue airline on the RU circuit for leaks. Check all fittings, tees, and dump valves on the RU circuit. Repair leaks as needed & then turn up pressure back to 0psi.
- Step 4:** Turn down pressure (RD) & wheel track (WT) pressure to 30psi, exit the tractor cab, & start at the compressor housing checking all black airlines on the RD & WT circuit for leaks. Check all fittings, tees, & dump valves on the RD & WT circuit. Repair leaks as needed.
- Step 5:** With tank pressure around 145psi, compressor not running, & 0psi commanded in all circuits, note the tank psi. Start a stop watch & after 5 minutes, note the tank pressure. If tank pressure drops more the 2psi, check for leaks around/inside the compressor housing & control box. Repair as needed.
- Step 6:** With tank pressure around 145psi, compressor not running, and 30psi commanded in all circuits, note the tank psi. Start a stop watch & after 5 minutes, note the tank pressure. If tank pressure drops more the 2psi, check for leaks on the row cleaner fittings, tees, and dump valves. Repair as needed.

## **AIR COMPRESSOR PRE-OPERATING TEST PROCEDURE:**

Before beginning this test, run the compressor system leak test and ensure it passes. There should be virtually no leaks in the tank circuit before performing this test. Use a stop watch to time the compressor's recovery time. Start the time when the tank gauge reaches 85psi & the compressor turns on. Stop the time when the compressor shuts off at 145psi. If the time is greater than 4 minutes, there is a leak, low battery power, or the compressor is worn. Repair as needed.

## **Proper Operation Settings**

### **Dump Valve Delay**

To set the dump valve delay, start at the operating screen, press **Menu**, select **Set Up**, press **Enter** to edit, & use the following guide to set to your planter size:

#### **Non Split Row Planters**

- 6-12 row planters - .5 seconds
- 16 row planters - .75-1.0 seconds

#### **Split Row Planters**

- 6/11, 6/12, 8/15, or 8/16 planters - .5 – .75 seconds using only corn rows, .75 – 1.5 seconds when using all rows

**Note:** When the dump valve delay is set properly, the action of the residue managers (RM) will be as follows:

- Pressing the Roman numeral I button (up indicator light on) should raise all RMs
- Pressing the Roman numeral I button (up indicator light off) will lower RMs to half travel & then settle into position

### **Air Pressure Settings**

**Residue Managers Only** - A common question is "What pressures should I start out at?" A good starting pressure setting would be 35psi Up Pressure, 30psi Down Pressure, & 32psi Wheel Track(WT). This particular setting will give each row cleaner a nice sturdy float. If this pressure setting doesn't remove enough residue or trenches/digs furrows, adjust the settings accordingly until the row cleaner is doing exactly what you want it to do. If the row cleaner is trenching, lessen the down pressure or increase the up pressure. If not enough residue is removed, lessen the up pressure or increase the down pressure. Once a setting is found, hold the desired preset button (P1-P5) until saved. Each field may require a different setting even though field conditions seem the same. For example, if you use a setting for one no-till field planting corn in soybean residue, you may find that the setting used for the next field planting corn in soybean residue in no-till conditions may be different. The reason may be the amount of residue, soil types, moisture amounts, etc.

**Residue managers/Coulter Combos** - A common question is "What pressures should I start out at?" A good starting pressure setting would be 40psi Up Pressure, 35psi Down Pressure, & 37psi Wheel Track (WT). This particular setting will give each row cleaner a nice sturdy float. If this pressure setting doesn't remove enough residue or trenches/digs furrows, adjust the settings accordingly until the row cleaner is doing exactly what you want it to do. If the row cleaner is trenching, lessen the down pressure or increase the up pressure. If not enough residue is removed, lessen the up pressure or increase the down pressure. Once a setting is found, hold the desired preset button (P1-P5) until saved. Each field may require a different setting even though field conditions seem the same. For example, if you use a setting for one no-till field planting corn in soybean residue, you may find that the setting used for the next field planting corn in soybean residue in no-till conditions may be different. The reason may be the amount of residue, soil types, moisture amounts, etc.

# Maintenance

## 2940 SYSTEM MAINTENANCE



**Step 1:** Remove the pre-cleaner (if equipped) from the filter cover. Remove the filter cap by turning the cap clockwise.

**Step 2:** Clean the pre-cleaner & filter.

**Step 3:** Install the filter & filter cap, placing the tab in the slots & turning the cap counter clockwise. Make sure the breather hole on the filter cap is facing down. Install the pre-cleaner.

### DAILY

Check air filter cleanliness, clean/replace as needed.

Check airlines for air leaks and repair as needed.

Check component parts of the compressor for damage (pressure switch, cooling fan, gauge, etc)

Open Tank Drain Valve (10 seconds) (see illustration to the right) to allow moisture to drain----->

Clean the interior of the control box & compressor

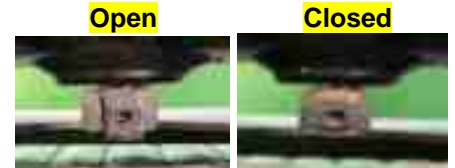

### SEASONALLY/200 COMPRESSOR HOURS

Replace air filter element (Part number for filter is 2940-395, part number for filter pre-cleaner is 2940-396)

Check/Clean the all connectors, inspect harness/cables for damage

### Lubrication Symbols



Lubricate with grease at hourly interval indicated on symbol.

### Lubrication Intervals

#### Residue Manager/Coulter Combo

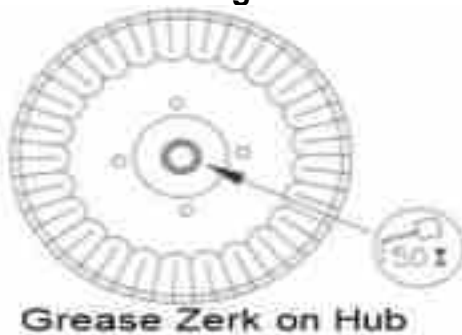

**IMPORTANT:** The recommended service intervals are based on normal conditions; severe or unusual conditions may require more frequent lubrication.

### AIR BAG REPLACEMENT

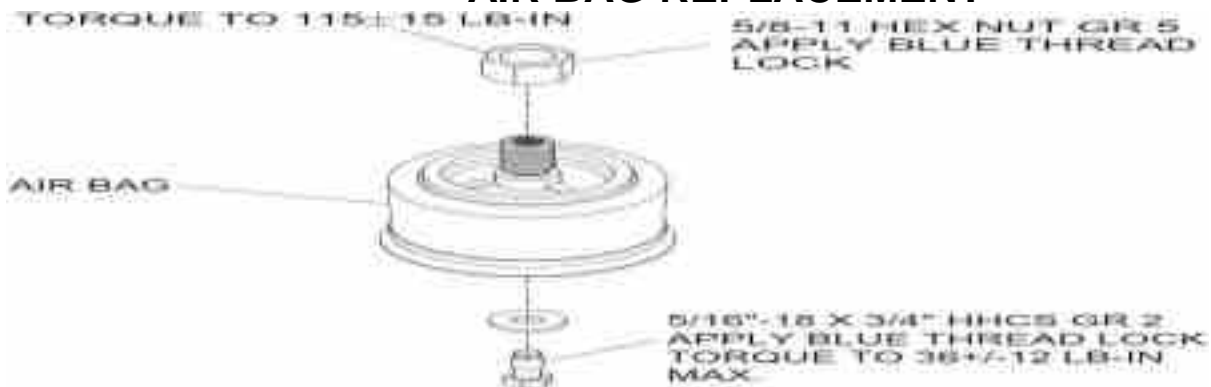

2940-386

6" AIR BAG

2940-388

8" AIR BAG

# 2940-049A PARTS IDENTIFICATION

## MANUFACTURED 06/2017 – PRESENT

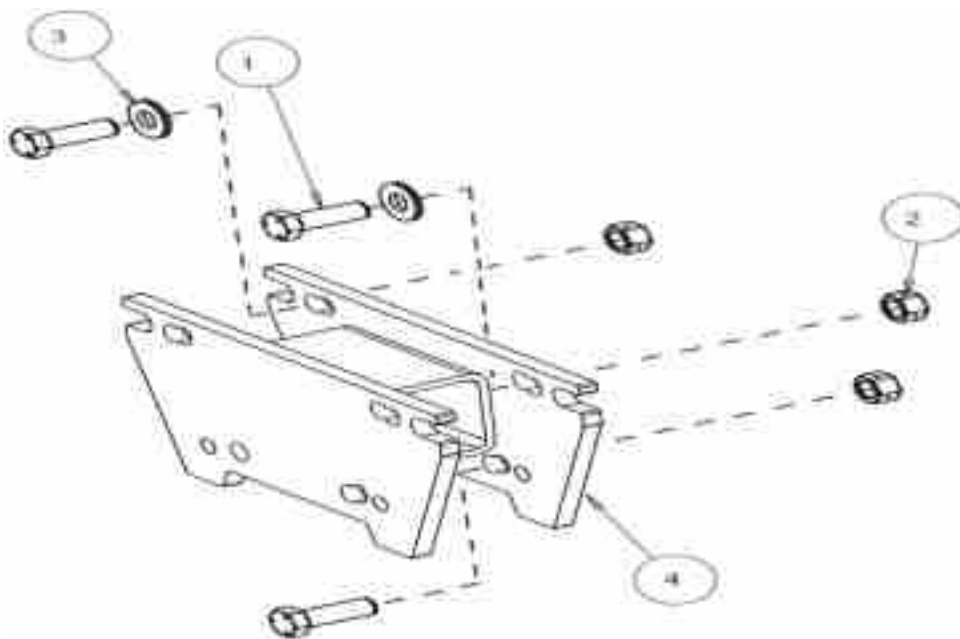

Item	Part Number	Description	Qty
1	2502-294	1/2-13 x 1-1/2 HHCS GR 5 ZP	3
2	2520-357	1/2-13 HEX LOCK NUT ZP	3
3	2526-355	1/2 FLAT WASHER HARDENED ZP	2
4	2940-220	MOUNT EXTENSION W.A.	1
5	5000-339	WASHER, MOUNT PLATE	2

# 2940-190A PARTS IDENTIFICATION

MANUFACTURED 07/2017 – PRESENT

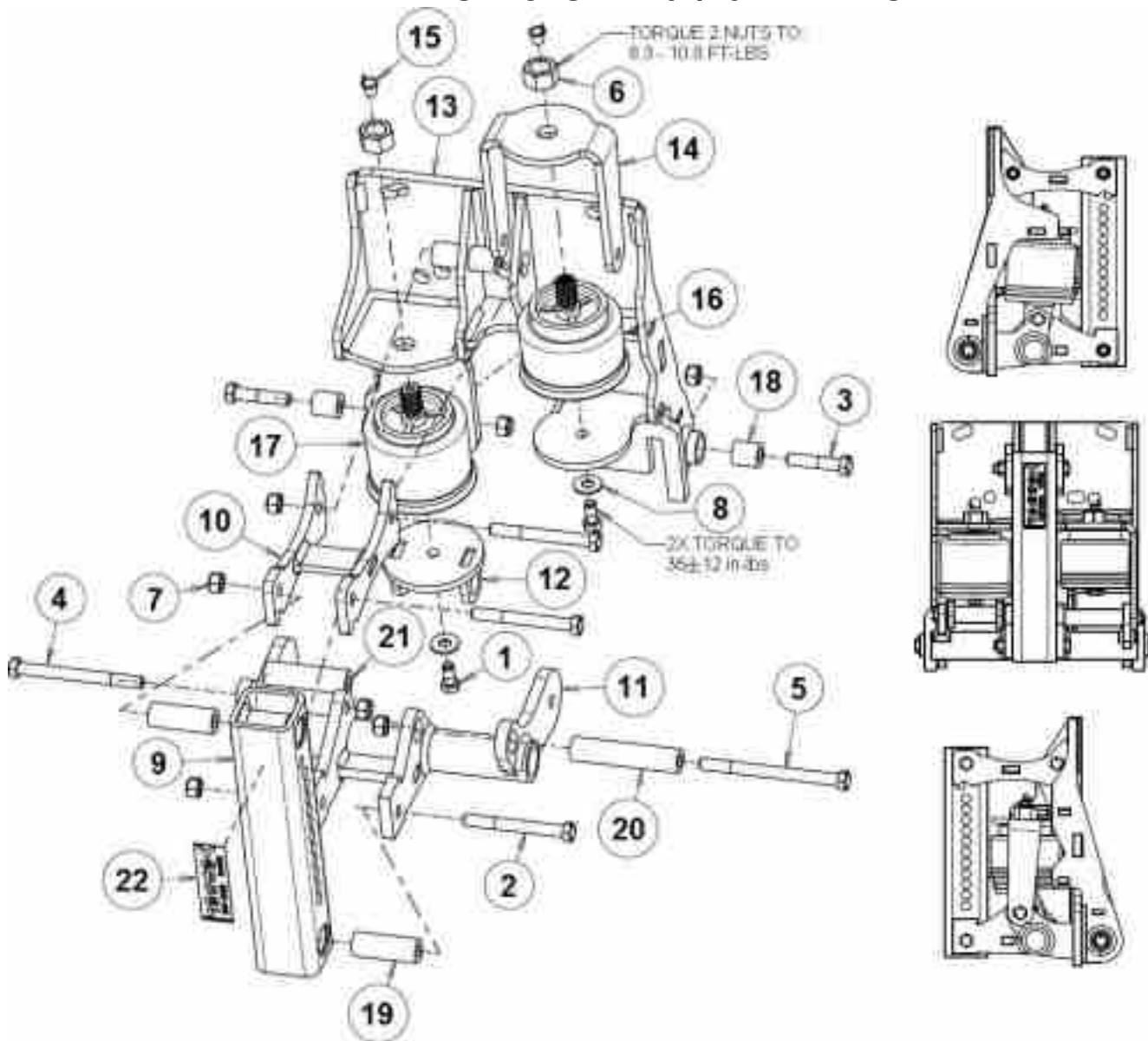

Item	Part Number	Description	Qty
1	2502-200	5/16 – 18 X 3/4 HHCS W/ THREAD LOCK GR 2 ZP	2
2	2502-233	3/8 – 16 X 3 1/4 HHCS GR 5 ZP	3
3	2502-245	3/8 – 16 X 1 1/4 HHCS GR 5 ZP	2
4	2502-254	3/8 – 16 X 4 HHCS GR 5 ZP	1
5	2502-260	3/8 – 16 X 4 1/2 HHCS GR 5 ZP	1
6	2520-455	5/8 – 11 HEX NUT ZP PATCH LOC GR 5	2
7	2520-601	3/8 – 16 HEX TOP LOCK GR C ZP	7
8	2526-201	5/16 STANDARD FLAT WASHER	2
9	2940-210	ADJUSTMENT TUBE	1
10	2940-211A	UPPER LINK W.A.	1
11	2940-213	LOWER PARALLEL	1
12	2940-214	AIR BAG BRACKET W.A.	1
13	2940-222A	R.M. MOUNT PLATE W.A.	1
14	2940-309	UPFORCE TOP MOUNT	1
15	2940-340	AIR BAG CAP PLUG	2
16	2940-386	SHORTER AIR BAG	1
17	2940-388	LARGER AIR BAG	1
18	2940-472	BUSHING	2
19	2940-473	BUSHING	3
20	2940-474	BUSHING	1
21	2940-478	.750" OD X .406" ID X 2.630" BUSHING	1
22	2940-590	YETTER VERTICAL DECAL	1



# 2940-192A PARTS IDENTIFICATION

MANUFACTURED 07/2017 – PRESENT

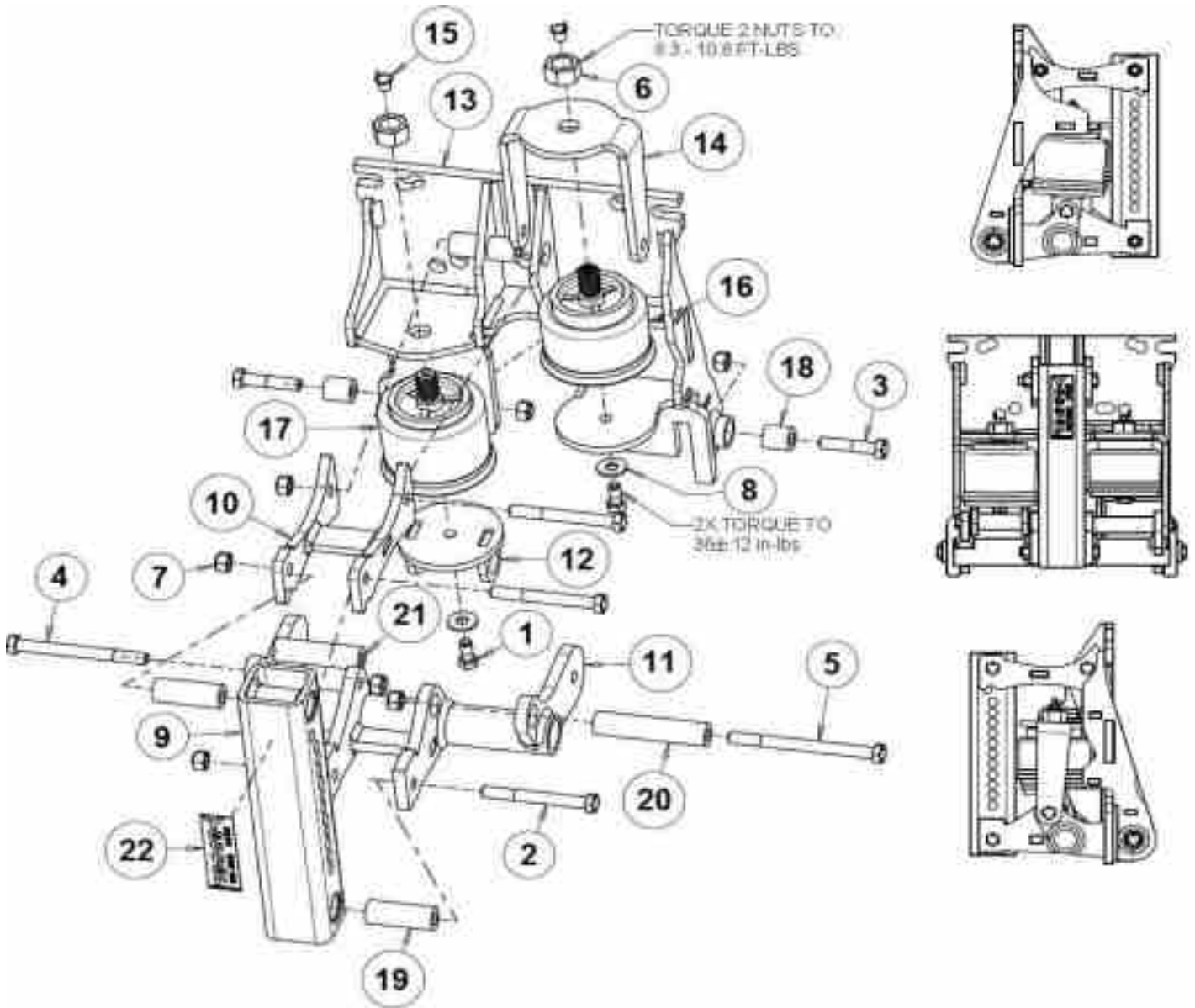

Item	Part Number	Description	Qty
1	2502-200	5/16 – 18 X 3/4 HHCS W/ THREAD LOCK GR 2 ZP	2
2	2502-233	3/8 – 16 X 3 1/4 HHCS GR 5 ZP	3
3	2502-245	3/8 – 16 X 1 1/4 HHCS GR 5 ZP	2
4	2502-254	3/8 – 16 X 4 HHCS GR 5 ZP	1
5	2502-260	3/8 – 16 X 4 1/2 HHCS GR 5 ZP	1
6	2520-455	5/8 – 11 HEX NUT ZP PATCH LOC GR 5	2
7	2520-601	3/8 – 16 HEX TOP LOCK GR C ZP	7
8	2526-201	5/16 STANDARD FLAT WASHER	2
9	2940-210	ADJUSTMENT TUBE	1
10	2940-211A	UPPER LINK W.A.	1
11	2940-213	LOWER PARALLEL	1
12	2940-214	AIR BAG BRACKET W.A.	1
13	2940-223A	R.M. MOUNT PLATE W.A.	1
14	2940-309	UPFORCE TOP MOUNT	1
15	2940-340	AIR BAG CAP PLUG	2
16	2940-386	SHORTER AIR BAG	1
17	2940-388	LARGER AIR BAG	1
18	2940-472	BUSHING	2
19	2940-473	BUSHING	3
20	2940-474	BUSHING	1
21	2940-478	.750" OD X .406" ID X 2.630" BUSHING	1
22	2940-590	YETTER VERTICAL DECAL	1

# 2940-001B & 2940-002B PARTS IDENTIFICATION

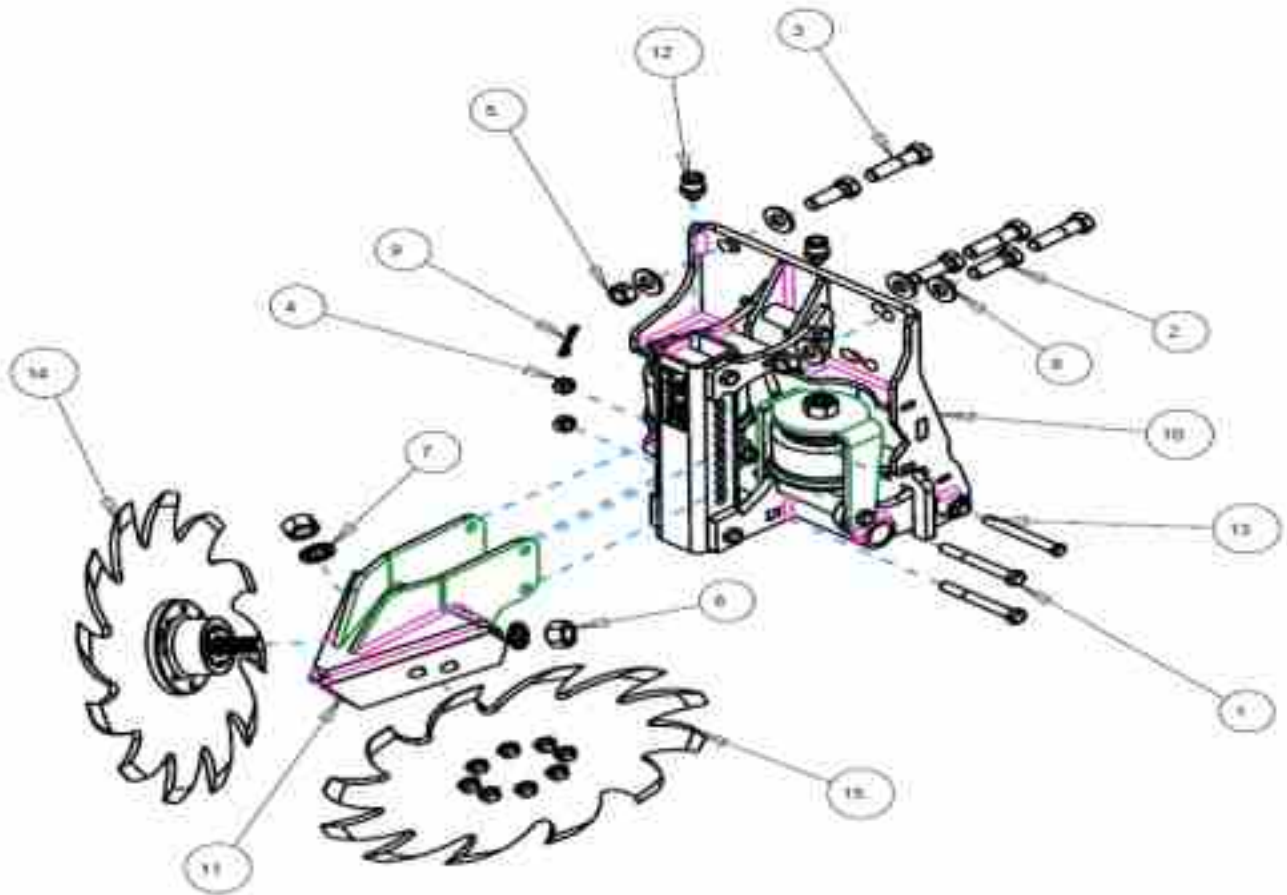

Item	Part Number	Description	Qty
1	2502-246	3/8-16 X 3 HHCS GR5 ZP	2
2	2502-294	1/2-13 X 1 1/2 HHCS GR5 ZP	3
3	2502-351	1/2-13 X 2 HHCS GR 5 ZP (MOUNTING TO AGCO 9000)	3
4	2520-255	3/8-16 LOCK HEX NUT, GR A, ZP	2
5	2520-357	1/2-13 LOCK HEX NUT, GR A, ZP	3
6	2520-452	5/8-11 HEX NUT ZP	2
7	2525-451	5/8 MEDIUM LOCKWASHER ZP	2
8	2526-355	1/2 FLAT WASHER HARDENED ZP	6
9	2570-445	HAIRPIN COTTER	1
10	2940-190A	PNEUMATIC R.M. MOUNT ASSEMBLY	1
11	2940-215	AIR ADJUST WIDE STEM W.A. (2940-001B)	1
	2940-216	AIR ADJUST NARROW STEM W.A. (2940-002B)	1
12	2940-380	3/8 PC X 1/8 BSPP O-RING STRAIGHT FITTING	2
13	2940-399	PIN	1
14	2966-140	SPOKE WHEEL ASSEMBLY, RH, 3" D-BOLT	1
	2966-140-BW	BEVEL WHEEL ASSEMBLY, RH, 3" D-BOLT	1
	2966-140-BW-FW	BEVEL WHEEL ASSEMBLY, RH, 3" D-BOLT WITH FLOATER WHEEL	1
	2966-140-FW	SPOKE WHEEL ASSEMBLY, RH, 3" D-BOLT WITH FLOATER WHEEL	1
	2966-140-HD	HD SPOKE WHEEL ASSEMBLY, RH, 3" D-BOLT	1
	2966-140-HD-FW	HD SPOKE WHEEL ASSEMBLY, RH, 3" D-BOLT WITH FLOATER WHEEL	1
	2966-140-ST	SHARKTOOTH ASSEMBLY, RH, 3" D-BOLT	1
	2966-140-ST-FW	SHARKTOOTH ASSEMBLY, RH, 3" D-BOLT WITH FLOATER WHEEL	1
15	2966-141	SPOKE WHEEL ASSEMBLY, LH, 3" D-BOLT	1
	2966-141-BW	BEVEL WHEEL ASSEMBLY, LH, 3" D-BOLT	1
	2966-141-BW-FW	BEVEL WHEEL ASSEMBLY, LH, 3" D-BOLT WITH FLOATER WHEEL	1
	2966-141-FW	SPOKE WHEEL ASSEMBLY, LH, 3" D-BOLT WITH FLOATER WHEEL	1
	2966-141-HD	HD SPOKE WHEEL ASSEMBLY, LH, 3" D-BOLT	1
	2966-141-HD-FW	HD SPOKE WHEEL ASSEMBLY, LH, 3" D-BOLT WITH FLOATER WHEEL	1
	2966-141-ST	SHARKTOOTH ASSEMBLY, LH, 3" D-BOLT	1
	2966-141-ST-FW	SHARKTOOTH ASSEMBLY, LH, 3" D-BOLT WITH FLOATER WHEEL	1
16	2967-392	SHIELD, RM-PAINTED (BEVEL & TAPER TOOTH WHEELS ONLY)	2

# 2940-003B & 2940-004B PARTS IDENTIFICATION

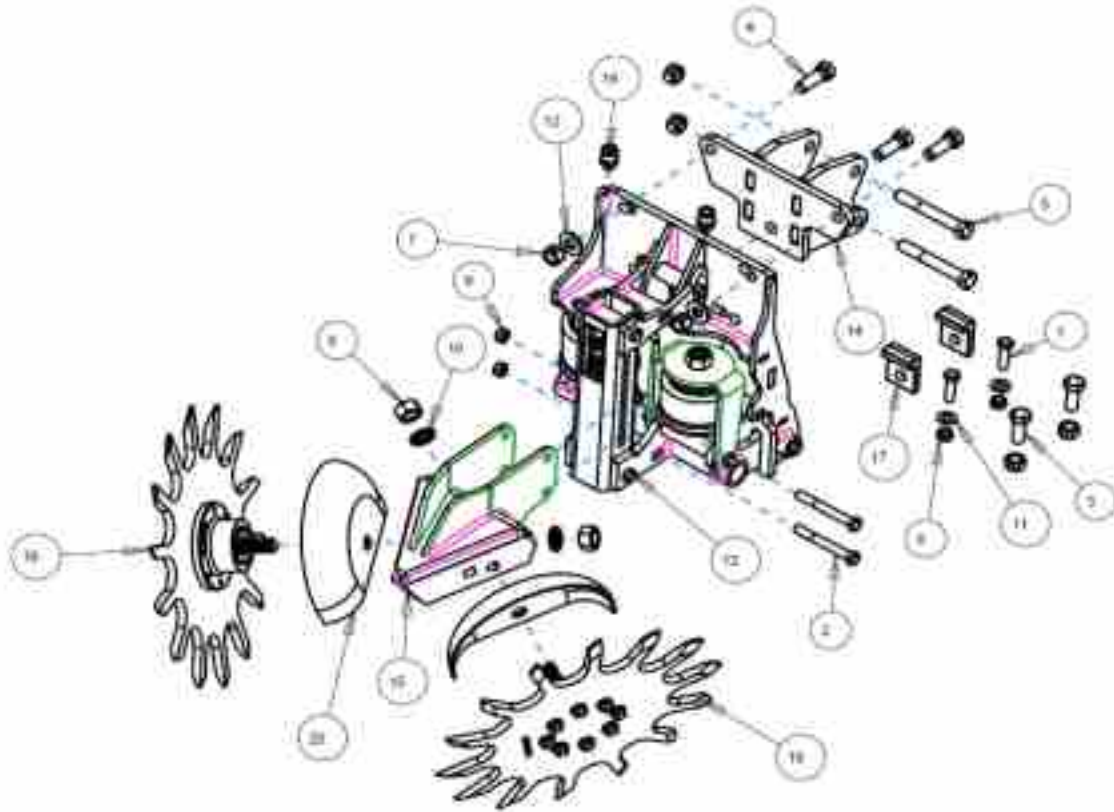

Item	Part Number	Description	Qty
1	2502-244	3/8 – 16 X 1 – ¼ HHCS GR 5 ZP (FOR CYCLO STOP CASTING)	2
	2502-293	1/2-13 X 1-1/4 HHCS GR5 ZP (FOR CYCLO STOP CASTING)	2
2	2502-246	3/8-16 X 3 HHCS GR5 ZP	2
3	2502-293	½-13 X 1 1/4 HHCS GR5	2
4	2502-294	½-13 X 1 ½ HHCS GR5 ZP	3
5	2502-316	1/2-13 X 3-1/2 HHCS GR5 ZP	2
6	2520-255	3/8-16 LOCK HEX NUT. GR A, ZP (FOR CYCLO STOP CASTING)	2
7	2520-357	½-13 LOCK HEX NUT, GR A, ZP	7
8	2520-452	5/8-11 HEX NUT ZP	2
9	2520-601	3/8 – 16 HEX TOP LOCK NUT, GR C, ZP	2
10	2525-451	5/8 MEDIUM LOCKWASHER ZP	2
11	2526-253	3/8 SAE FLAT WASHER ZP (FOR CYCLO STOP CASTING)	2
12	2526-355	½ FLAT WASHER HARDENED ZP	3
13	2940-190A	PNEUMATIC R.M. MOUNT ASSEMBLY	1
14	2940-209	CNH ADAPTOR BRACKET	1
	2966-293	CNH ADAPTOR BRACKET	1
15	2940-215	AIR ADJUST WIDE STEM W.A. (2940-003B)	1
	2940-216	AIR ADJUST NARROW STEM W.A. (2940-004B)	1
16	2940-380	3/8 PC X 1/8 BSPP O-RING STRAIGHT FITTING	2
17	2960-411	CYCLO STOP CASTING, LARGE HOLE	2
18	2966-140	SPOKE WHEEL ASSEMBLY, RH, 3" D-BOLT	1
	2966-140-BW	BEVEL WHEEL ASSEMBLY, RH, 3" D-BOLT	1
	2966-140-BW-FW	BEVEL WHEEL ASSEMBLY, RH, 3" D-BOLT WITH FLOATER WHEEL	1
	2966-140-FW	SPOKE WHEEL ASSEMBLY, RH, 3" D -BOLT WITH FLOATER WHEEL	1
	2966-140-HD	HD SPOKE WHEEL ASSEMBLY, RH, 3" D-BOLT	1
	2966-140-HD-FW	HD SPOKE WHEEL ASSEMBLY, RH, 3" D-BOLT WITH FLOATER WHEEL	1
	2966-140-ST	SHARKTOOTH ASSEMBLY, RH, 3" D-BOLT	1
	2966-140-ST-FW	SHARKTOOTH ASSEMBLY, RH, 3" D-BOLT WITH FLOATER WHEEL	1
19	2966-141	SPOKE WHEEL ASSEMBLY, LH, 3" D-BOLT	1
	2966-141-BW	BEVEL WHEEL ASSEMBLY, LH, 3" D-BOLT	1
	2966-141-BW-FW	BEVEL WHEEL ASSEMBLY, LH, 3" D-BOLT WITH FLOATER WHEEL	1
	2966-141-FW	SPOKE WHEEL ASSEMBLY, LH, 3" D-BOLT WITH FLOATER WHEEL	1
	2966-141-HD	HD SPOKE WHEEL ASSEMBLY, LH, 3" D-BOLT	1
	2966-141-HD-FW	HD SPOKE WHEEL ASSEMBLY, LH, 3" D-BOLT WITH FLOATER WHEEL	1
	2966-141-ST	SHARKTOOTH ASSEMBLY, LH, 3" D-BOLT	1
	2966-141-ST-FW	SHARKTOOTH ASSEMBLY, LH, 3" D-BOLT WITH FLOATER WHEEL	1
20	2967-392	SHIELD (BEVEL& TAPER TOOTH WHEELS ONLY)	2

# 2940-005B & 006B PARTS IDENTIFICATION

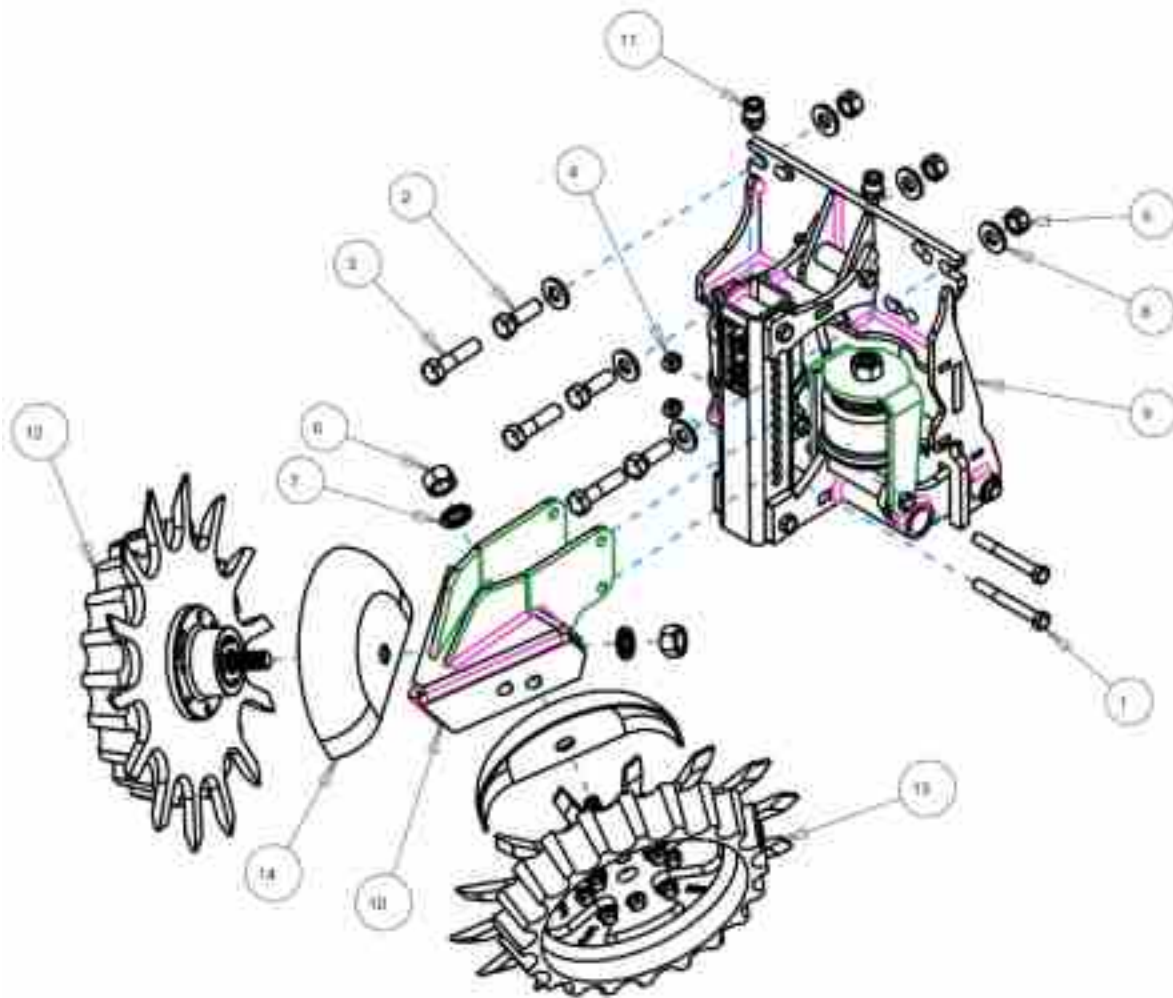

Item	Part Number	Description	Qty
1	2502-246	3/8-16 X 3 HHCS GR5 ZP	2
2	2502-294	1/2-13 X 1 1/2 HHCS GR5 ZP	3
3	2502-351	1/2-13 X 2 HHCS GR5 ZP	3
4	2520-255	3/8-16 LOCK NUT, GR A, ZP	2
5	2520-357	1/2-13 LOCK HEX NUT, GR A, ZP	3
6	2520-452	5/8-11 HEX NUT ZP	2
7	2525-451	5/8 MEDIUM LOCKWASHER ZP	2
8	2526-355	1/2 FLAT WASHER HARDENED ZP	6
9	2940-192A	PNEUMATIC R.M. MOUNT ASSEMBLY	1
10	2940-215	AIR ADJUST WIDE STEM W.A. (2940-005B)	1
	2940-216	AIR ADJUST NARROW STEM W.A. (2940-006B)	1
11	2940-380	3/8 PC X 1/8 BSPP O-RING STRAIGHT FITTING	2
12	2966-140	SPOKE WHEEL ASSEMBLY, RH, 3" D-BOLT	1
	2966-140-BW	BEVEL WHEEL ASSEMBLY, RH, 3" D-BOLT	1
	2966-140-BW-FW	BEVEL WHEEL ASSEMBLY, RH, 3" D-BOLT WITH FLOATER WHEEL	1
	2966-140-FW	SPOKE WHEEL ASSEMBLY, RH, 3" D-BOLT WITH FLOATER WHEEL	1
	2966-140-HD	HD SPOKE WHEEL ASSEMBLY, RH, 3" D-BOLT	1
	2966-140-HD-FW	HD SPOKE WHEEL ASSEMBLY, RH, 3" D-BOLT WITH FLOATER WHEEL	1
	2966-140-ST	SHARKTOOTH ASSEMBLY, RH, 3" D-BOLT	1
	2966-140-ST-FW	SHARKTOOTH ASSEMBLY, RH, 3" D-BOLT WITH FLOATER WHEEL	1
13	2966-141	SPOKE WHEEL ASSEMBLY, LH, 3" D-BOLT	1
	2966-141-BW	BEVEL WHEEL ASSEMBLY, LH, 3" D-BOLT	1
	2966-141-BW-FW	BEVEL WHEEL ASSEMBLY, LH, 3" D-BOLT WITH FLOATER WHEEL	1
	2966-141-FW	SPOKE WHEEL ASSEMBLY, LH, 3" D-BOLT WITH FLOATER WHEEL	1
	2966-141-HD	HD SPOKE WHEEL ASSEMBLY, LH, 3" D-BOLT	1
	2966-141-HD-FW	HD SPOKE WHEEL ASSEMBLY, LH, 3" D-BOLT WITH FLOATER WHEEL	1
	2966-141-ST	SHARKTOOTH ASSEMBLY, LH, 3" D-BOLT	1
	2966-141-ST-FW	SHARKTOOTH ASSEMBLY, LH, 3" D-BOLT WITH FLOATER WHEEL	1
14	2967-392	SHIELD (BEVEL & TAPER TOOTH WHEEL ONLY)	2

# 2940-126A PARTS IDENTIFICATION

MANUFACTURED 07/17 – PRESENT

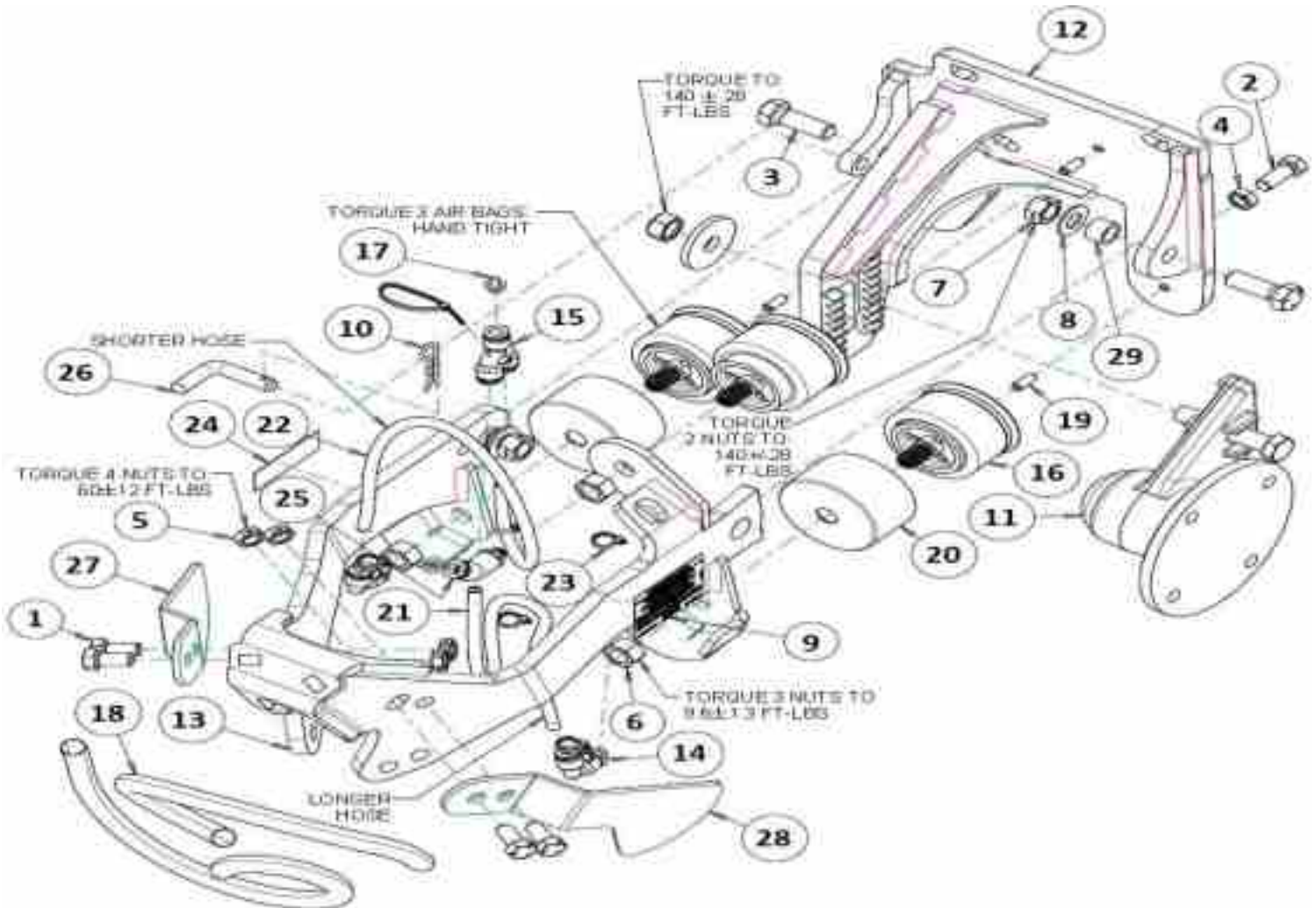

Part Number	Description	Qty	
1	2502-292	1/2-13 X 1 HHCS GR 5 ZP	4
2	2502-293	1/2-13 X 1 1/4 HHCS GR 5 ZP	1
3	2502-331	5/8-11 X 1 3/4 HHCS GR 5 ZP	2
4	2520-356	1/2-13 JAM HEX NUT ZP	1
5	2520-364	1/2-13 JAM HEX LOCK NUT	4
6	2520-455	5/8-11 HEX NUT WITH PATCH LOC, GR 5 ZP	3
7	2520-459	5/8-11 HEX LOCK NUT ZP	2
8	2526-453	5/8 SAE FLAT WASHER ZP	2
9	2565-505	FRAME HEIGHT DECAL	1
10	2570-446	.125 HAIRPIN COTTER ZP	1
11	2940-121	ASSEMBLY, COULTER HUB	1
12	2940-230	FACEPLATE W.A. JD 1700,7200, AGCO 9000	1
13	2940-231	COMBO ARM W.A.	1
14	2940-381	3/8 PC X 1/8 BSPP O-RING 90 DEGREE	2
15	2940-383	3/8 PC WYE FITTING	1
16	2940-386	SHORTER AIR BAG	3
17	2940-389	RUBBER AIR BAG PLUG	2
18	2940-508	HOSE SLEEVE	2
19	2940-560	SET SCREW, .313-18 X .750 W/ THREAD LOCK	3
20	2940-569	AIR BAG SHIELD	2
21	2940-571	HOSE, LH COMBO 2940 AIR SYSTEMS	1
22	2940-572	HOSE, RH COMBO 2940 AIR SYSTEMS	1
23	2940-577	ZIP TIE	5
24	2940-589	YETTER HORIZONTAL DECAL 1" X 3"	1
25	2940-609	3/8 PC X 1/8 BSPP O-RING	1
26	2967-613	TITAN PIN, JD ZP	1
27	2967-630	SCRAPER, RH	1
28	2967-631	SCRAPER, LH	1
29	6000-335	9/16" BUSHING	2

# 2940-130A PARTS IDENTIFICATION

MANUFACTURED 07/17 – PRESENT

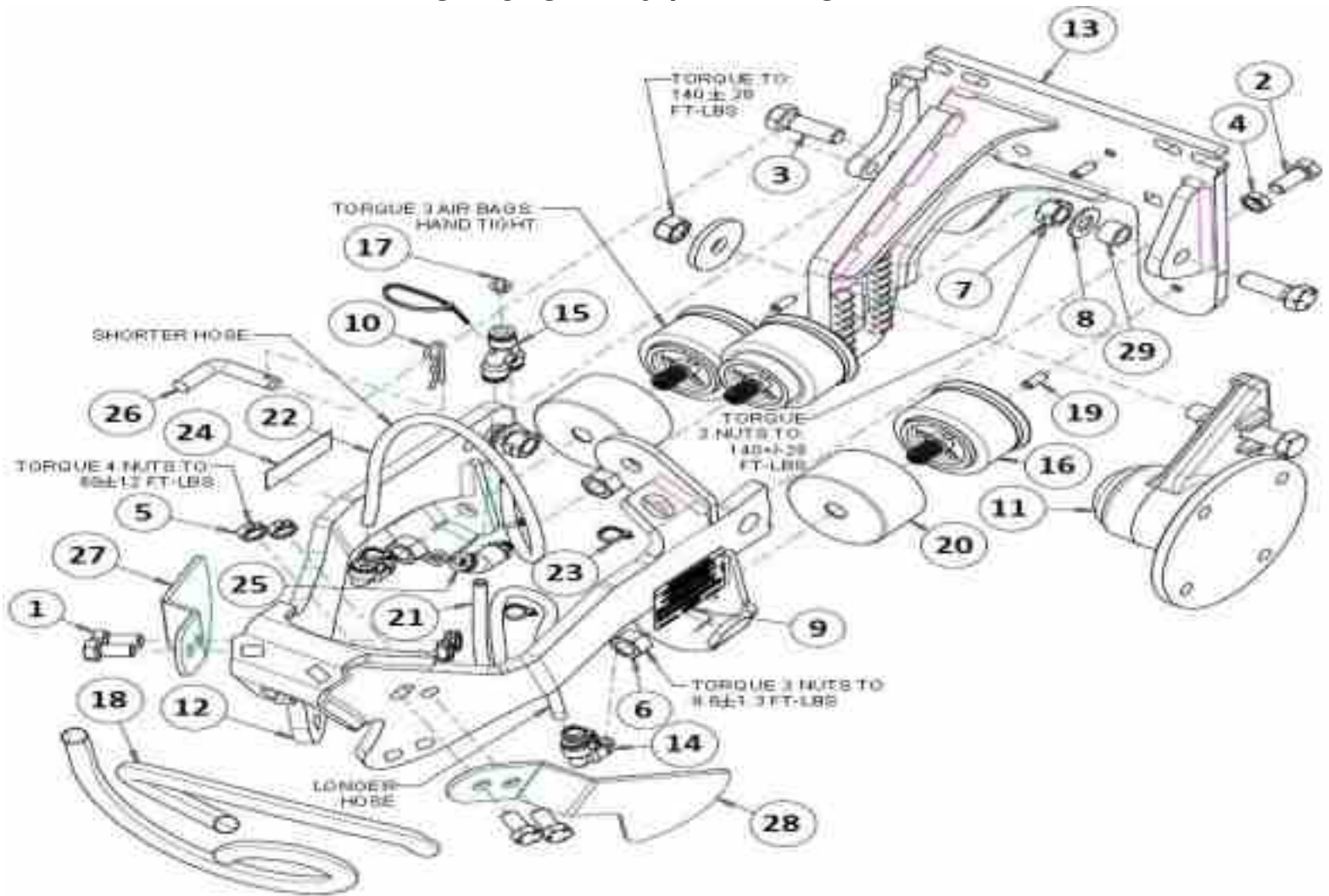

	Part Number	Description	Qty
1	2502-292	1/2-13 X 1 HHCS GR 5 ZP	4
2	2502-293	1/2-13 X 1 1/4 HHCS GR 5 ZP	1
3	2502-331	5/8-11 X 1 3/4 HHCS GR 5 ZP	2
4	2520-356	1/2-13 JAM HEX NUT ZP	1
5	2520-364	1/2-13 JAM HEX LOCK NUT	4
6	2520-455	5/8-11 HEX NUT WITH PATCH LOC, GR 5 ZP	3
7	2520-459	5/8-11 HEX LOCK NUT ZP	2
8	2526-454	5/8 SAE FLAT WASHER HARDENED ZP	2
9	2565-505	FRAME HEIGHT DECAL	1
10	2570-446	.125 HAIRPIN COTTER ZP	1
11	2940-121	ASSEMBLY, COULTER HUB	1
12	2940-230	FACEPLATE W.A. JD 1700,7200, AGCO 9000	1
13	2940-231	COMBO ARM W.A.	1
14	2940-381	3/8 PC X 1/8 BSPP O-RING 90 DEGREE	2
15	2940-383	3/8 PC WYE FITTING	1
16	2940-386	SHORTER AIR BAG	3
17	2940-389	RUBBER AIR BAG PLUG	2
18	2940-508	HOSE SLEEVE	2
19	2940-560	SET SCREW, .313-18 X .750 W/ THREAD LOCK	3
20	2940-569	AIR BAG SHIELD	2
21	2940-571	HOSE, LH COMBO 2940 AIR SYSTEMS	1
22	2940-572	HOSE, RH COMBO 2940 AIR SYSTEMS	1
23	2940-577	ZIP TIE	5
24	2940-589	YETTER HORIZONTAL DECAL 1" X 3"	1
25	2940-609	3/8 PC X 1/8 BSPP O-RING	1
26	2967-613	TITAN PIN, JD ZP	1
27	2967-630	SCRAPER, RH	1
28	2967-631	SCRAPER, LH	1
29	6000-335	9/16" BUSHING	2

# 2940-007B PARTS IDENTIFICATION

JD 7000, AGCO 6000 & 8000  
KINZE 2000, 3000, 4900

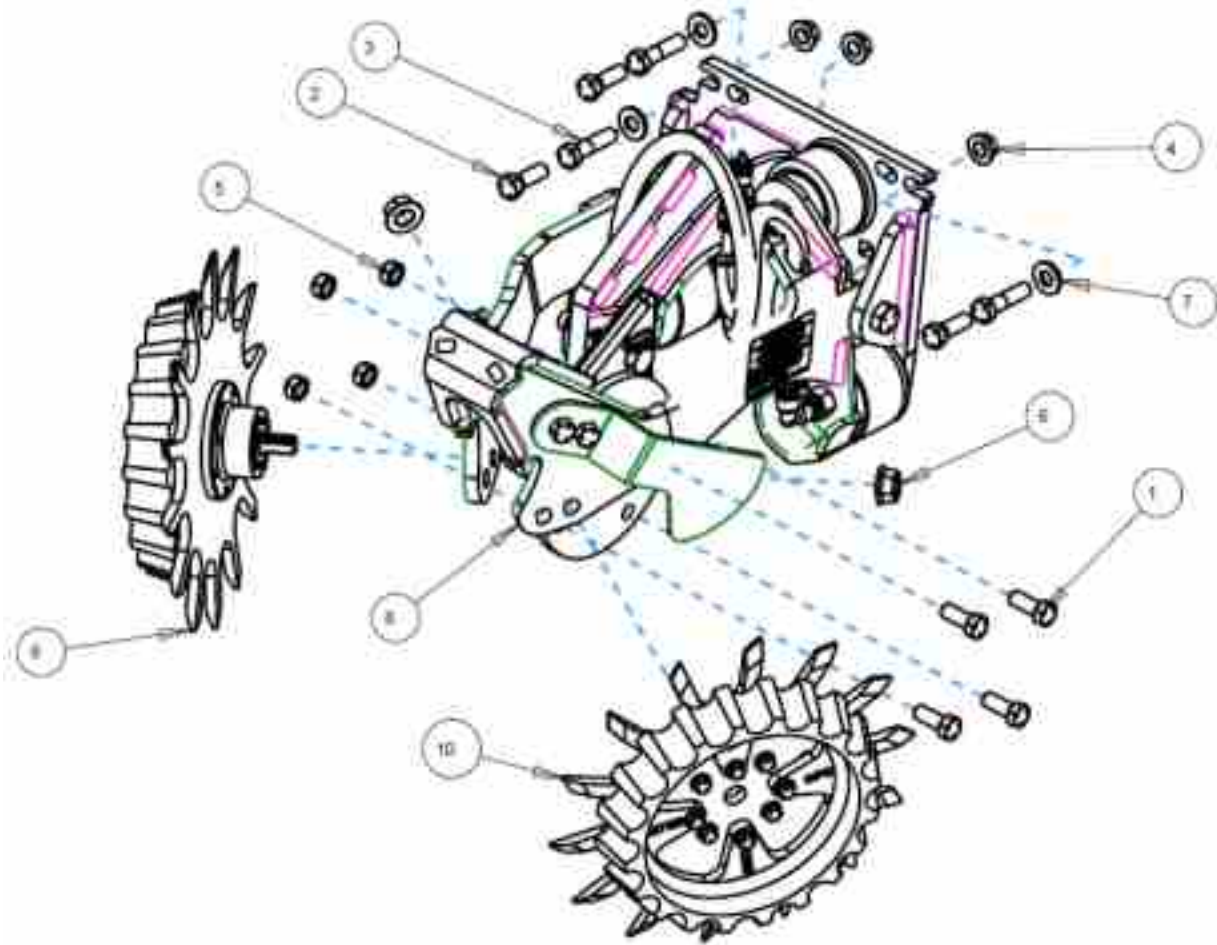

Item	Part Number	Description	Qty
1	2502-293	½-13 X 1 ¼ HHCS GR 5 ZP	4
2	2502-294	½-13 X 1 ½ HHCS GR 5 ZP	3
3	2502-351	½-13 X 2 HHCS GR 5 ZP (FOR MOUNTING TO AGCO 9000)	3
4	2520-361	½-13 FLANGE WHIZLOCK HEX NUT GR 5 ZP	3
5	2520-362	½-13 HEX LOCK NUT GR C ZP	4
6	2520-464	5/8-11 WHIZLOCK HEX NUT GR 2 ZP	2
7	2526-355	½ FLAT WASHER HARDENED ZP	3
8	2940-130A	PNEUMATIC COMBO SUBASSEMBLY FOR JD 1700 & 7200, AGCO 9000	1
9	2966-116-FW	SPOKE WHEEL ASSEMBLY, RH, 2 3-4" D-BOLT WITH FLOATER WHEEL	1
	2966-116-ST-FW	SHARK TOOTH WHEEL ASSEMBLY, RH, 2 3/4" D-BOLT WITH FLOATER WHEEL	1
	2966-116-BW-FW	BEVEL WHEEL ASSEMBLY, RH, 2 3/4" D-BOLT WITH FLOATER WHEEL	1
10	2966-117-FW	SPOKE WHEEL ASSEMBLY, LH, 2 3-4" D-BOLT WITH FLOATER WHEEL	1
	2966-117-ST-FW	SHARK TOOTH WHEEL ASSEMBLY, LH, 2 3/4" D-BOLT WITH FLOATER WHEEL	1
	2966-117-BW-FW	BEVEL WHEEL ASSEMBLY, LH, 2 3/4" D-BOLT WITH FLOATER WHEEL	1

# 2940-010B PARTS IDENTIFICATION

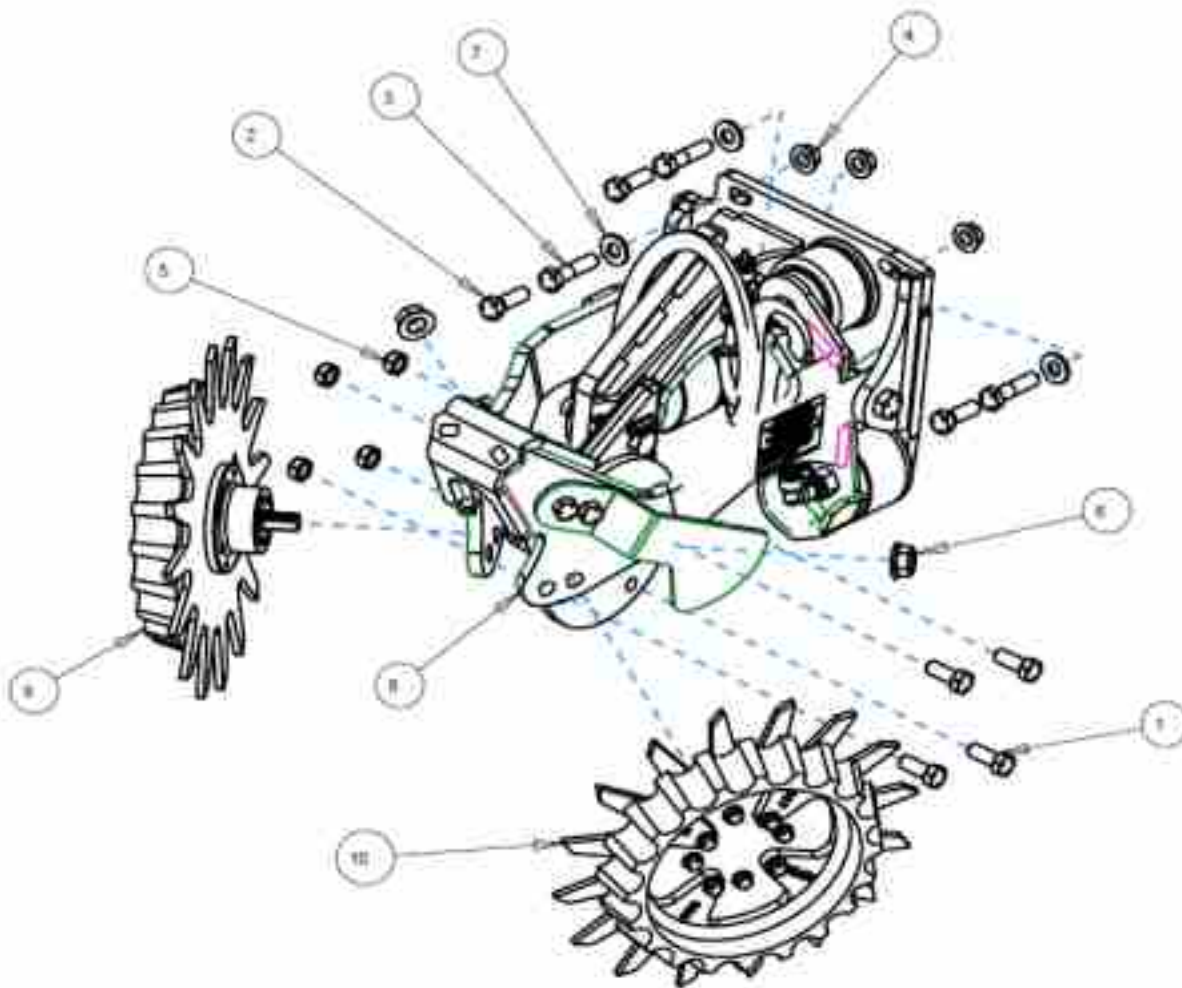

JD 1700-7200 AGCO 9000

Item	Part Number	Description	Qty
1	2502-293	1/2-13 X 1 1/4 HHCS GR 5 ZP	4
2	2502-294	1/2-13 X 1 1/2 HHCS GR 5 ZP	3
3	2502-351	1/2-13 X 2 HHCS GR 5 ZP (FOR MOUNTING TO AGCO 9000)	3
4	2520-361	1/2-13 FLANGE WHIZLOCK HEX NUT GR 5 ZP	3
5	2520-362	1/2-13 HEX LOCK NUT GR C ZP	4
6	2520-464	5/8-11 WHIZLOCK HEX NUT GR 2 ZP	2
7	2526-355	1/2 FLAT WASHER HARDENED ZP	3
8	2940-126A	PNEUMATIC COMBO SUBASSEMBLY	1
9	2966-116-FW	SPOKE WHEEL ASSEMBLY, RH, 2 3-4" D-BOLT WITH FLOATER WHEEL	1
	2966-116-ST-FW	SHARK TOOTH WHEEL ASSEMBLY, RH, 2 3/4" D-BOLT WITH FLOATER WHEEL	1
	2966-116-BW-FW	BEVEL WHEEL ASSEMBLY, RH, 2 3/4" D-BOLT WITH FLOATER WHEEL	1
10	2966-117-FW	SPOKE WHEEL ASSEMBLY, LH, 2 3-4" D-BOLT WITH FLOATER WHEEL	1
	2966-117-ST-FW	SHARK TOOTH WHEEL ASSEMBLY, LH, 2 3/4" D-BOLT WITH FLOATER WHEEL	1
	2966-117-BW-FW	BEVEL WHEEL ASSEMBLY, LH, 2 3/4" D-BOLT WITH FLOATER WHEEL	1



# PARTS IDENTIFICATION

## 2966-140-ST-FW RIGHT HAND SHARK TOOTH WHEEL ASSEMBLY

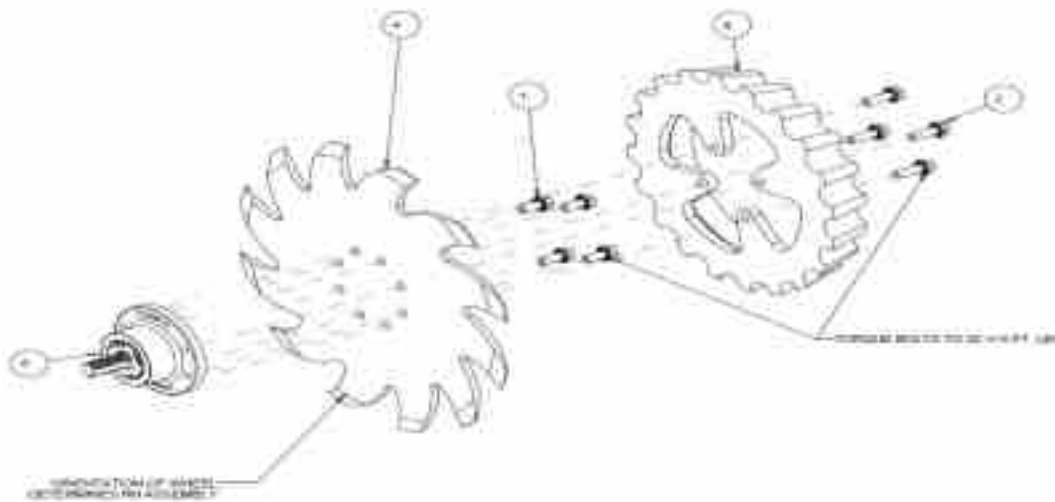

ITEM	PART NO.	DESCRIPTION	QTY
1	2502-220	5/16-18 X 3/4 HHFS GR5 ZP	4
2	2502-221	5/16-18 X 1 HHFS GR5 ZP	4
3	2515-562	13" WHEEL COVER, BLACK	2
4	2571-286	SHARKTOOTH WHEEL, 6 BOLT	1
5	2568-500	HUB ASSEMBLY, 1.406 SPINDLE	1
6	2567-560	FLOATER WHEEL	1

## 2966-140-ST-FW LEFT HAND SHARK TOOTH WHEEL ASSEMBLY

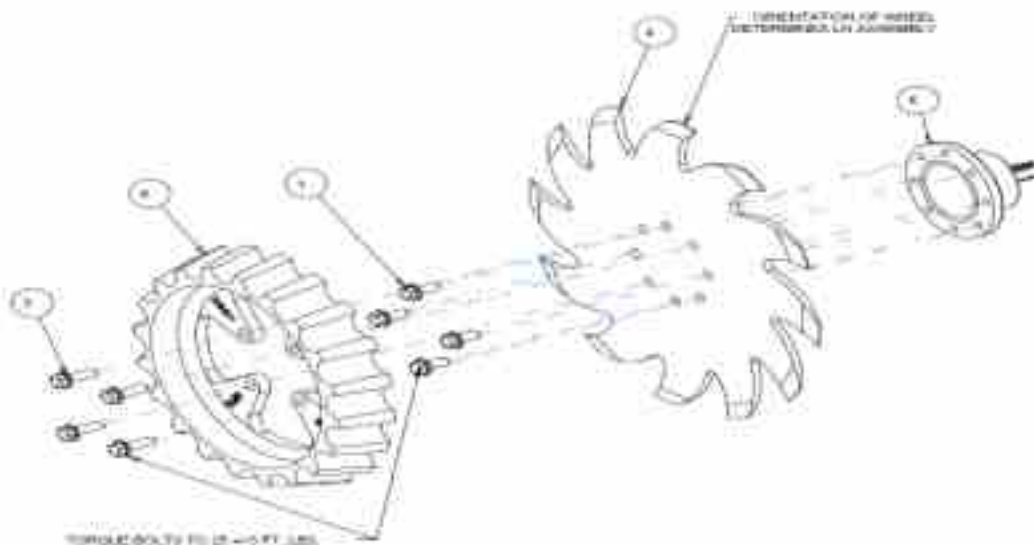

ITEM	PART NO.	DESCRIPTION	QTY
1	2502-220	5/16-18 X 3/4 HHFS GR5 ZP	4
2	2502-221	5/16-18 X 1 HHFS GR5 ZP	4
3	2515-562	13" WHEEL COVER, BLACK	2
4	2571-286	SHARKTOOTH WHEEL, 6 BOLT	1
5	2568-500	HUB ASSEMBLY, 1.406 SPINDLE	1
6	2567-560	FLOATER WHEEL	1

# PARTS IDENTIFICATION

2966-140-FW

## RIGHT HAND TAPER TOOTH WHEEL ASSEMBLY

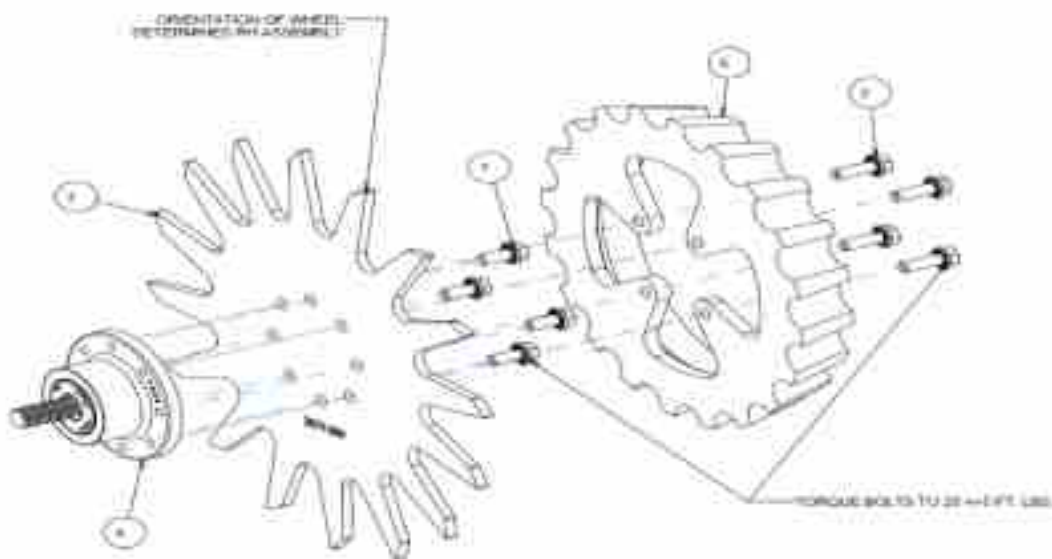

ITEM	PART NO.	DESCRIPTION	QTY
1	2502-220	5/16-18 X 3/4 HHFS GR5 ZP	4
2	2503-221	5/16-18 X 1 HHFS GR5 ZP	4
3	2571-289	13" TAPER TOOTH SPOKE WHEEL. 8 BOLT	1
4	2965-500	HUB ASSEMBLY. 1.406 SPINDLE	1
5	2967-560	FLOATER WHEEL	1

2966-141-FW

## LEFT HAND TAPER TOOTH WHEEL ASSEMBLY

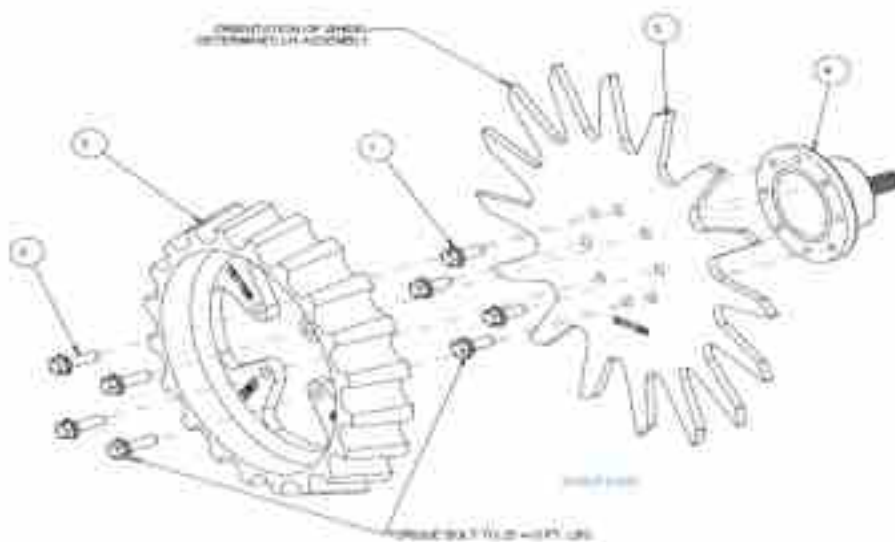

ITEM	PART NO.	DESCRIPTION	QTY
1	2502-220	5/16-18 X 3/4 HHFS GR5 ZP	4
2	2502-221	5/16-18 X 1 HHFS GR5 ZP	4
3	2571-289	13" TAPER TOOTH SPOKE WHEEL. 8 BOLT	1
4	2965-500	HUB ASSEMBLY. 1.406 SPINDLE	1
5	2967-560	FLOATER WHEEL	1

# PARTS IDENTIFICATION

2966-140-BW-FW

## RIGHT HAND BEVEL WHEEL ASSEMBLY

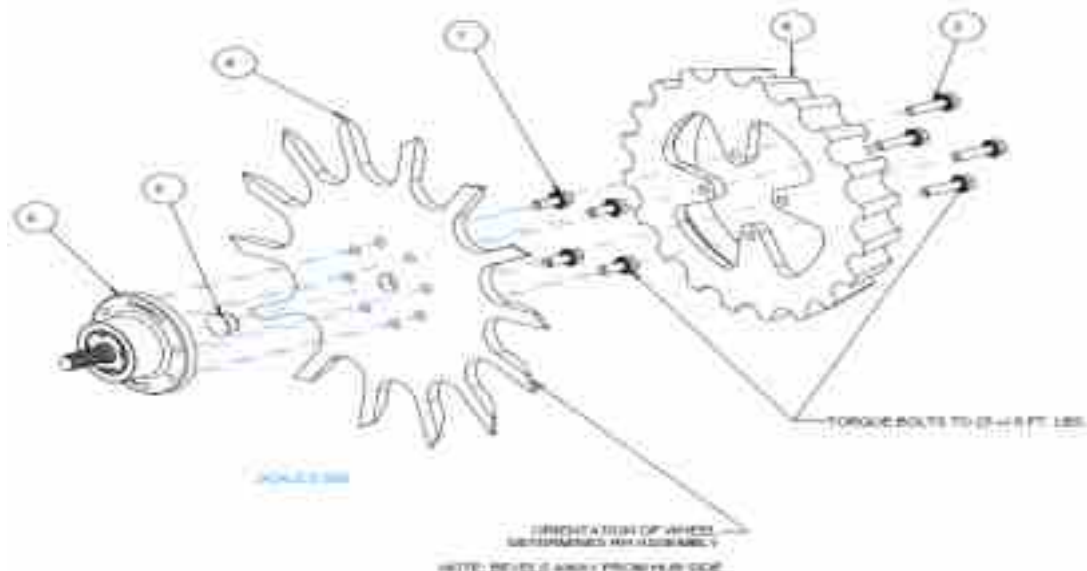

ITEM	PART NO.	DESCRIPTION	QTY
1	2502-220	5/16-18 X 3/4 HHFS GR5 ZP	4
2	2502-222	5/16-18 X 1-1/4 HHFS GR6 ZP	4
3	2570-994	BEVEL WHEEL CENTER HOLE PLUG	1
4	2571-287-R	13" BEVEL WHEEL, 8 BOLT, RH	1
5	2965-500	HUB ASSEMBLY, 1.406 SPINDLE	1
6	2967-560	FLOATER WHEEL	1

2966-141-BW-FW

## LEFT HAND BEVEL WHEEL ASSEMBLY

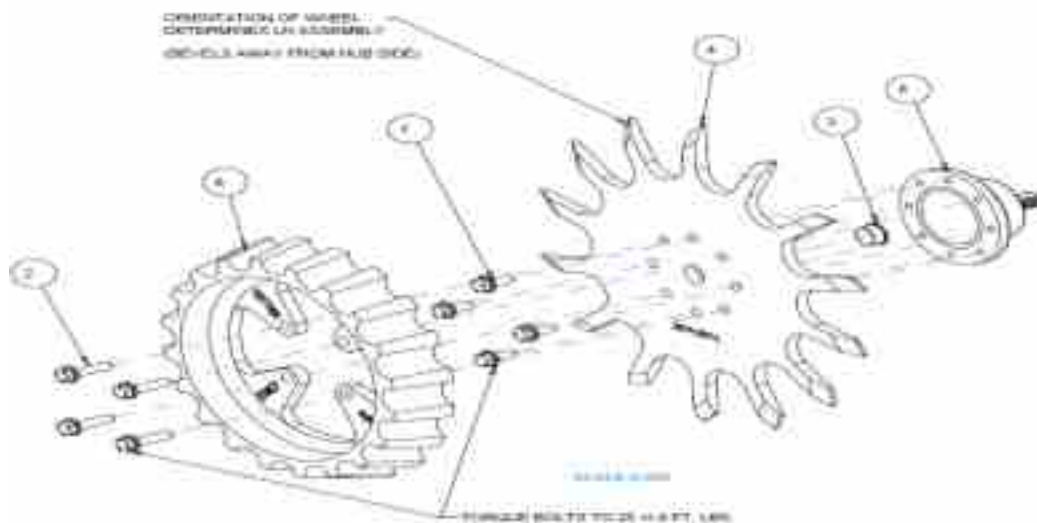

ITEM	PART NO.	DESCRIPTION	QTY
1	2502-220	5/16-18 X 3/4 HHFS GR5 ZP	4
2	2502-222	5/16-18 X 1-1/4 HHFS GR5 ZP	4
3	2570-994	BEVEL WHEEL CENTER HOLE PLUG	1
4	2571-287-L	13" BEVEL WHEEL, 8 BOLT, LH	1
5	2965-500	HUB ASSEMBLY, 1.406 SPINDLE	1
6	2967-560	FLOATER WHEEL	1

# PARTS IDENTIFICATION

2966-117-BW-FW BEVEL WHEEL LEFT HAND (SHOWN)

2966-117-ST-FW SHARK TOOTH WHEEL

2966-117-FW TAPER TOOTH WHEEL

2966-116-BW-FW BEVEL WHEEL RIGHT HAND

2966-116-ST-FW SHARK TOOTH

2966-116-FW TAPER TOOTH WHEEL

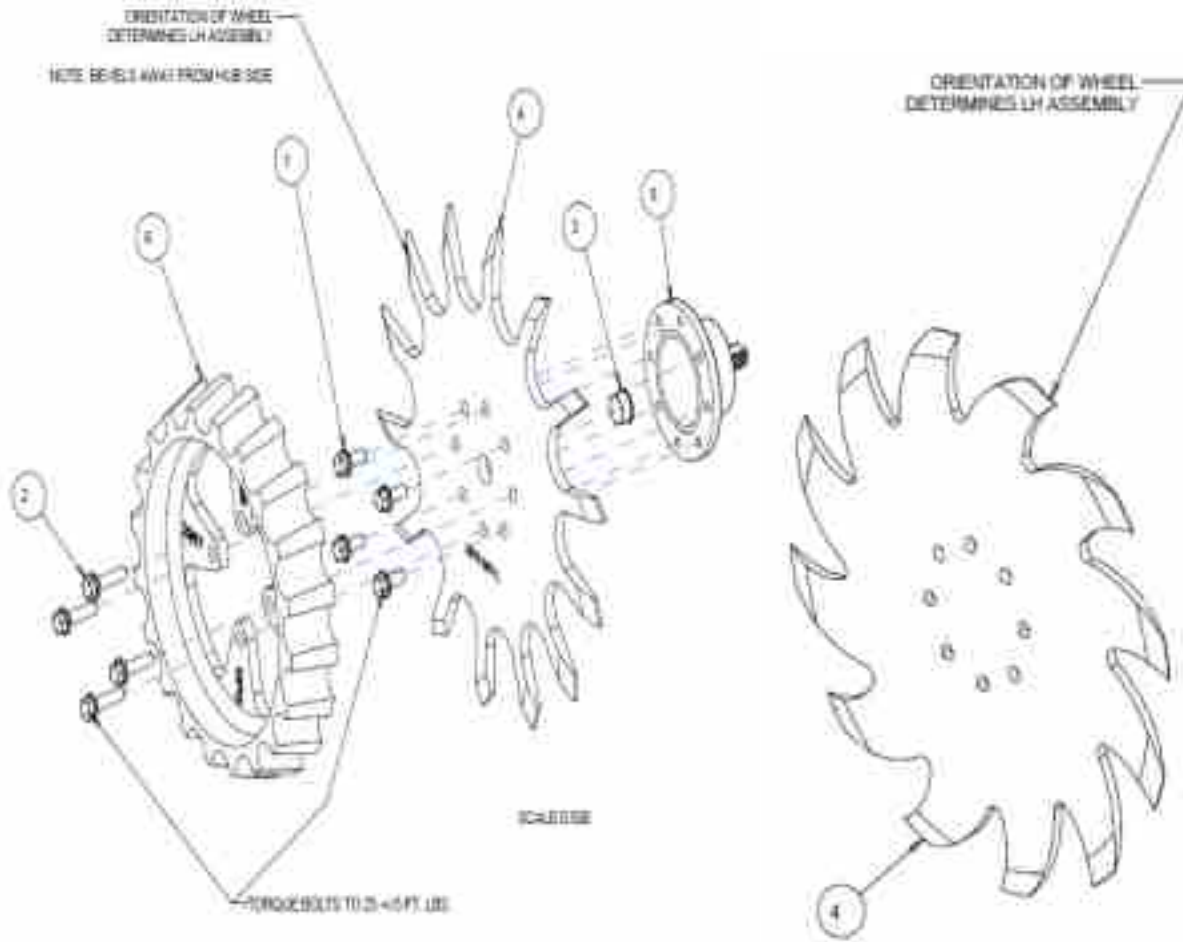

Item	Part Number	Description	Qty
1	2502-220	5/16-18 X ¾ HHFS	4
2	2502-222	5/16-18 X 1-1/4 HHFS	4
3	2570-994	PLUG (BEVEL WHEEL ONLY)	1
4	2571-287-L	13" BEVEL WHEEL 8 BOLT LH (SHOWN)	1
	2571-287-R	13" BEVEL WHEEL 8 BOLT RH	1
	2571-286	13" SHARKTOOTH WHEEL 8 BOLT	1
	2571-289	13" TAPER TOOTH WHEEL 8 BOLT	1
5	2965-502	HUB ASSEMBLY 1.157 SPINDLE	1
6	2967-560	FLOATER WHEEL	1

# PARTS IDENTIFICATION

25665-162  
YETTER DECAL, 1 1/2 X 4 1/2  
JD 7000, AGCO 6000, 8000, KINZE 5000, 4000

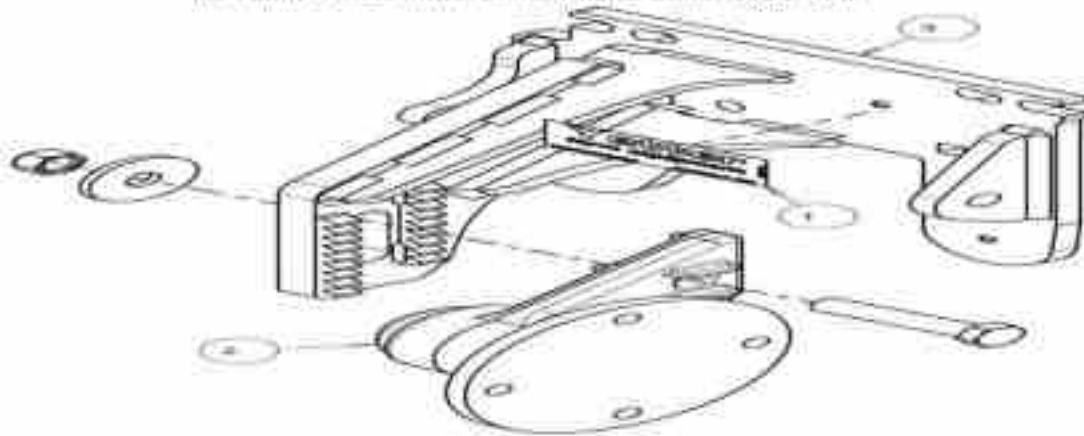

Item	Part Number	Description	Qty
1	2565-162	YETTER DECAL, 1 1/2 X 4 1/2	1
2	2940-121	ASSEMBLY, COULTER HUB	1
3	2940-232	FACEPLATE W.A., JD 7000, AGCO 6000 & 8000, KINZE	1

25665-162  
YETTER DECAL, 1 1/2 X 4 1/2  
JD 1700, 7200, AGCO 9000

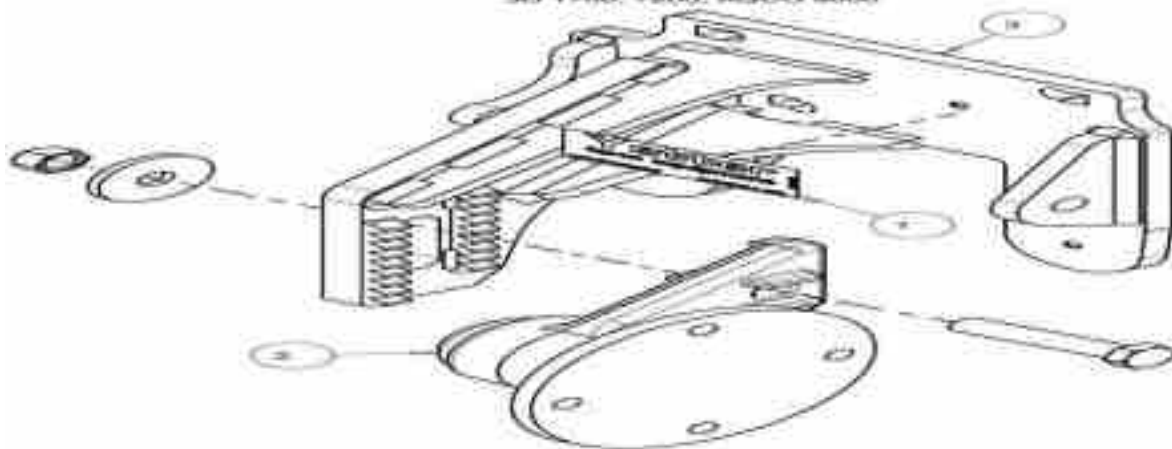

Item	Part Number	Description	Qty
1	2565-162	YETTER DECAL, 1 1/2 X 4 1/2	1
2	2940-121	ASSEMBLY, COULTER HUB	1
3	2940-230	FACEPLATE W.A., JD 1700 & 7200, AGCO 9000	1

## 2940-121 Coultter Hub

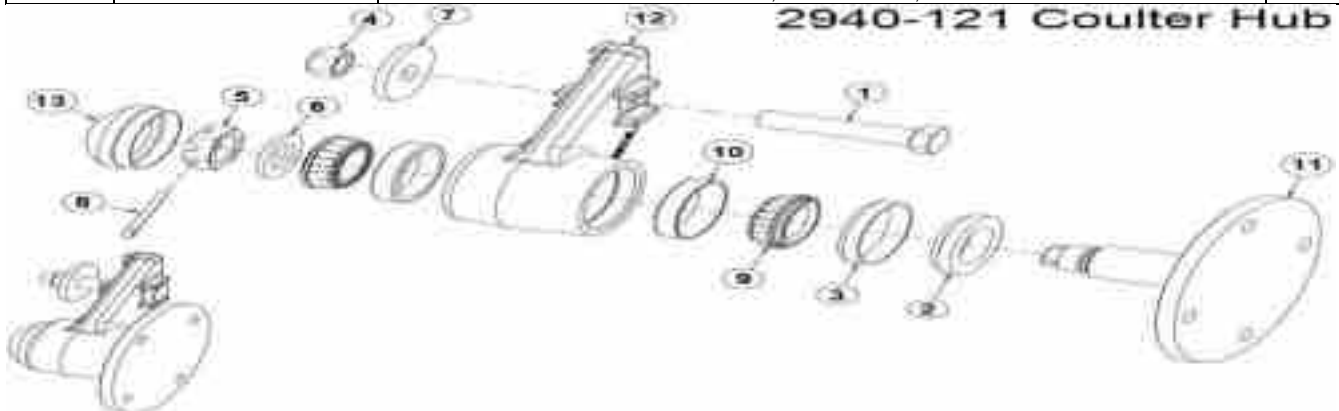

Item	Part Number	Description	Qty
1	2502-383	M16 X 2 X 80 HEX HEAD BOLT	1
2	2515-839	SEAL, COULTER	1
3	2515-840	SEAL, WHELL BEARING CUP	1
4	2520-475	M16 X 2 - 6H LOCK NUT CLASS 10.9 ZP	1
5	2520-569	1" - 14 CASTLE NUT	1
6	2526-581	M26 X 44 X 4 ROUND WASHER ZN	1
7	2526-583	SPECIAL FLAT WASHER	1
8	2531-177	M5 X 40 COTTER PIN ZP	1
9	2550-027-D	CONE, LM67010, KOYO	2
10	2550-029-D	CUP, LM67010, KOYO	2
11	2940-578	COULTER SPINDLE	1
12	2940-579	MACHINED HUB CASTING	1
13	D10025-BLK	HUB CAP BLACK	1

# PARTS IDENTIFICATION

2940-082  
5X7 & 7X7 BAR MOUNT KIT

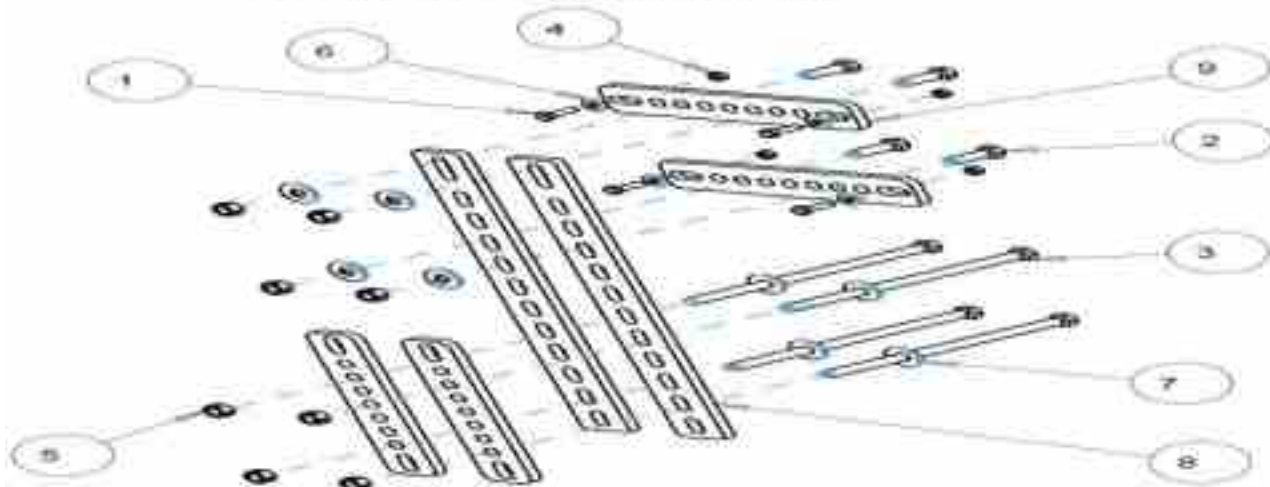

Item	Part Number	Description	Qty
1	2502-198	5/16-18 X 1 HHCS GR 5 ZP	4
2	2502-294	½-13 X 1-1/2 HHCS GR 5 ZP	4
3	2502-372	½-13 X 6 ½ HHCS GR5 ZP	4
	2502-374	½-13 X 9 HHCS GR 5 ZP	4
4	2520-205	5/16-18 LOCK HEX NUT ZP	4
5	2520-357	½-13 LOCK HEX NUT ZP	8
6	2526-201	5/16 STANDARD FLAT WASHER ZP	4
7	2526-351	½ STANDARD FLAT WASHER ZP	8
8	2940-344	MOUNT STRAP (LONG)	2
9	2940-355	MOUNT STRAP (SHORT)	4

2940-083  
8X16 & 8X12 BAR MOUNT KIT

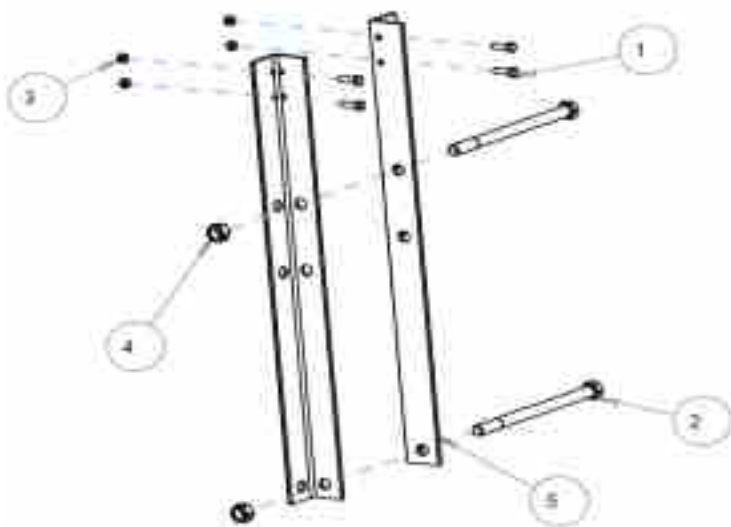

Item	Part Number	Description	Qty
1	2502-198	5/16-18 X 1 HHCS GR 5 ZP	4
2	2502-398	X 9 ½ HHCS GR 5 ZP	2
3	2520-205	5/16-18 LOCK HEX NUT ZP	4
4	2520-459	5/8-11 LOCK HEX NUT ZP	2
5	2940-479	ANGLE MOUNT BRACKET	2

2940-084  
UNIVERSAL HAND RAIL MOUNT KIT

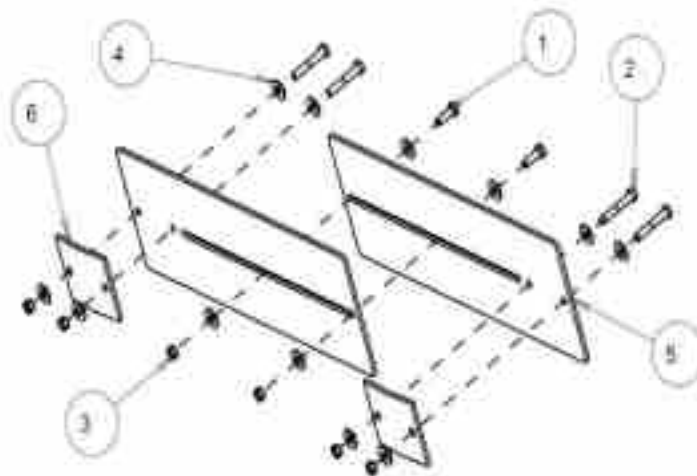

Item	Part Number	Description	Qty
1	2502-198	5/16-18 X 1 HHCS GR 5 ZP	7
2	2502-207	5/16-18 X 2 HHCS GR 5 ZP	4
	2502-212	5/16-18 X 2 ½ HHCS GR5 ZP	4
3	2520-205	5/16-18 LOCK HEX NUT ZP	11
4	2526-201	5/16 STANDARD FLAT WASHER ZP	18
5	2940-480	HAND RAIL TELESCOPING PLATE	2
6	2940-481	HAND RAIL CLAMP	2

# PARTS IDENTIFICATION

**2940-085 2 PT/UNIVERSAL  
COMPRESSOR MOUNT KIT**

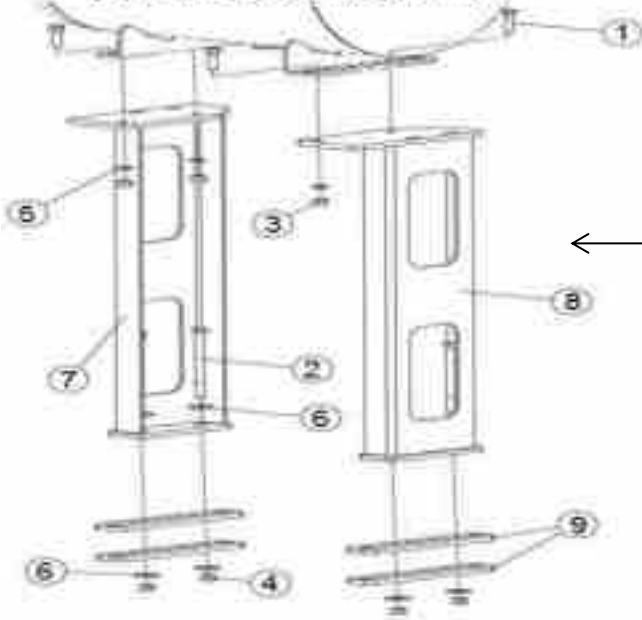

Item	Part Number	Description	Qty
1	2502-294	½-13 X 1 ½ HHCS GR 5 ZP	4
2	2502-373	½-13 X 6 HHCS GR 5 ZP	4
3	2520-352	½-13 HEX NUT ZP	4
4	2520-357	½-13 LOCK HEX NUT ZP	4
5	2525-352	½ MED LOCK WASHER ZP	4
6	2526-352	½ SAE FLAT WASHER ZP	8
7	2940-207	COMPRESSOR MOUNT W.A., LH	1
8	2940-208	COMPRESSOR MOUNT W.A., RH	1
9	2940-355	MOUNT STRAP	4

Item	Part Number	Description	Qty
1	2502-294	11½-13 X 1 ½ HHCS GR 5 ZP	8
2	2502-349	11½-13 X 5 FLTHD HHCS GR 5 ZP	4
3	2520-352	½½-13 HEX NUT ZP	12
4	2525-352	½ MED LOCK WASHER ZP	12
5	2526-351	½ STANDARD FLAT WASHER ZP	24
6	2940-344	COMPRESSOR STRAP	2
7	2940-351	COMPRESSOR MOUNT BRACKET	4

**2940-086 DRAFT TUBE/UNIVERSAL  
COMPRESSOR MOUNT KIT**

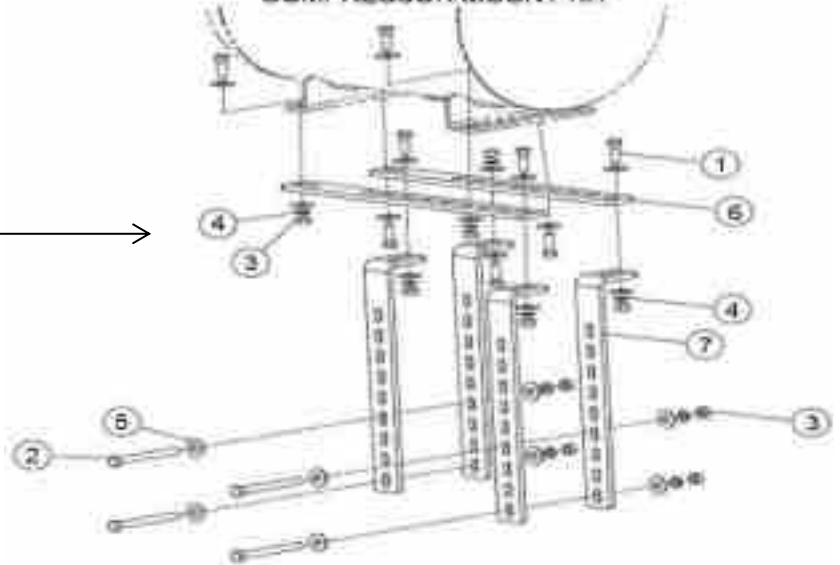

**2940-090 8x12 & 2940-091 8x16 HYD COMP MOUNT KIT**

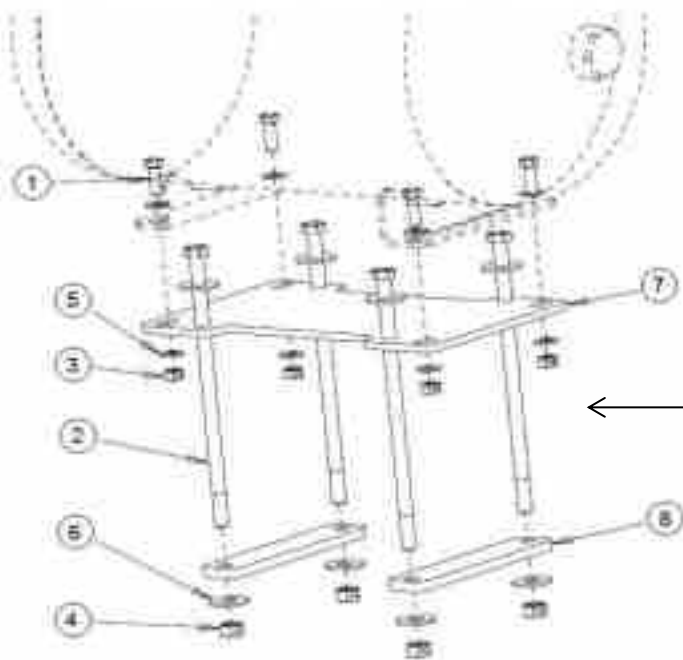

Item	Part Number	Description	Qty
1	2502-294	½-13 X 1 ½ HHCS GR 5 ZP	4
2	2502-388	5/8-11 X 14 HHCS GR 5 ZP (IN THE 2940-090 KIT)	4
	2502-389	5/8-11 X 18 HHCS GR 5 ZP (IN THE 2940-091 KIT)	4
3	2520-357	½-13 HEX LOCK NUT ZP	4
4	2520-459	5/8-11 HEX LOCK NUT ZP	4
5	2526-352	½ STANDARD FLAT WASHER ZP	8
6	2526-451	5/8 STANDARD FLAT WASHER ZP	8
7	2940-372	HYDRAULIC COMPRESSOR MOUNT PLATE	1
8	2940-373	MOUNT STRAP	2

## 2940-103 PARTS IDENTIFICATION

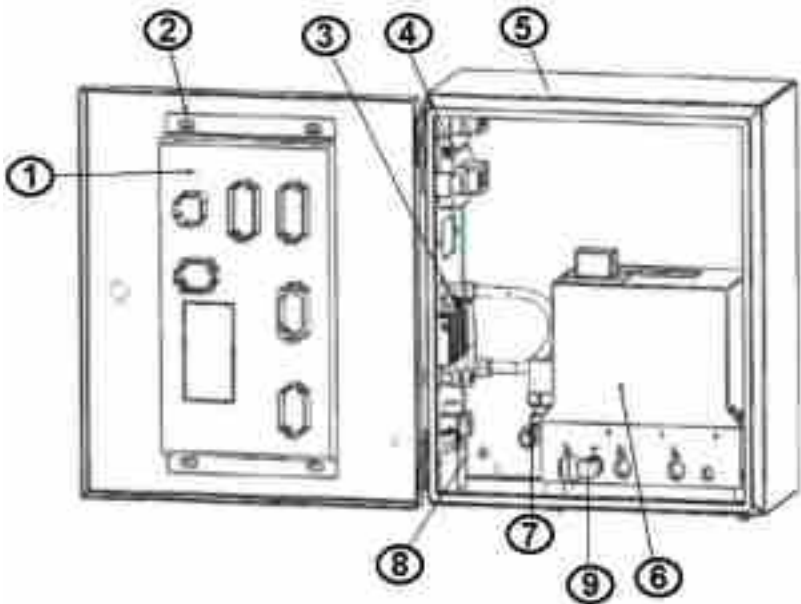

Item	Part Number	Description	Qty
1	2940-112	VDM	1
2	2940-442	SPACERS	4
3	2940-135	PRESSURE ON VALVE (DISCONTINUED AS OF 10/17/17)	1
4	N/A	HARNESING	2
5	N/A	ENCLOSURE	1
6	2940-402	PQE	1
7	2940-441	PRESSURE TRANSDUCER	1
8	2940-376	WATER SEPARATOR DUMP VALVE (1200-323 FITTINGS PART #)	1

## 2940-136 Dump Valve Kit

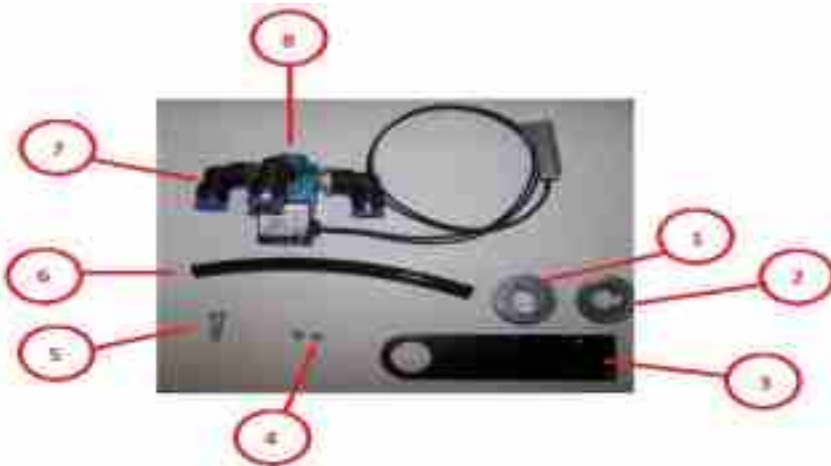

Item	Part Number	Description	Qty
1	14m7291	METRIC FLANGE HEX NUT	1
2	2520-464	5/8-11 SERRATED FLANGE NUT	1
3	2940-335	DUMP VALVE MOUNT TAB	1
4	2520-110	M5 HEX LOCK NUT	2
5	N/A	PHILIPS HEAD BOLT	2
6	2940-138	6" 3/8 DRAIN AIRLINE	1
7	2940-337	3/8 PTC ELBOW 1/8NPT	3
8	2940-336	VALVE	1

## 2940-415 PARTS IDENTIFICATION

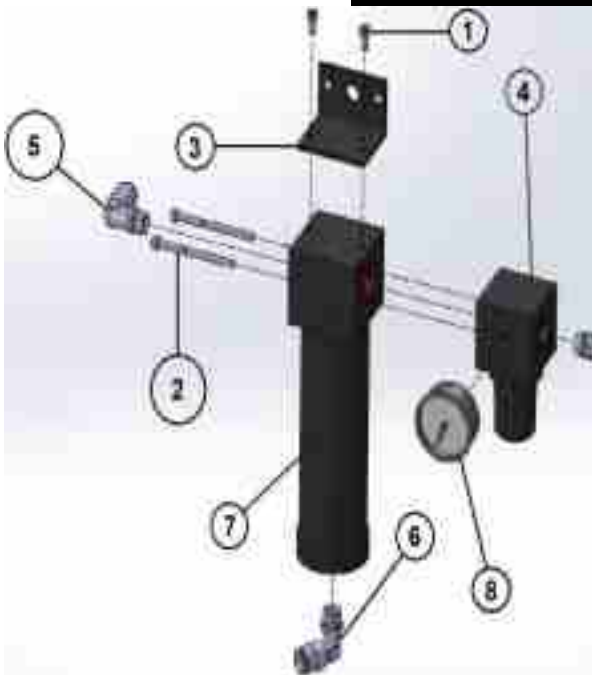

Item	Part Number	Description	Qty
1	N/A	SCREW, SEPARATOR TO MOUNTING BRACKET	2
2	N/A	SCREW, WATER SEPARATOR TO REGULATOR	2
3	N/A	MOUNTING BRACKET	1
4	2940-404	REGULATOR	1
5	2940-408	3/8PTC X 1/4NPT ELBOW AIR FITTING	2
6	2940-423	1/4PTC X 1/8NPT ELBOW AIR FITTING	1
7	2940-438	WATER SEPARATOR	1
8	2940-439	PRESSURE GAUGE	1



# Troubleshooting Guide

## Problem

## Cause

## Corrective Action

Problem	Cause	Corrective Action
Tank pressure drops when compressor shuts off	<ol style="list-style-type: none"> <li>1. check valve is leaking</li> <li>2. loose pneumatic connections</li> <li>3. water separator drain valve or head pressure relief valve leak</li> </ol>	<ol style="list-style-type: none"> <li>1. replace check valve</li> <li>2. perform leak test &amp; fix as needed (Page 44)</li> <li>3. replace water separator drain valve or head pressure relief valve</li> </ol>
Compressor runs continuously & air flow lower than normal	<ol style="list-style-type: none"> <li>1. excessive air usage</li> <li>2. loose pneumatic connections</li> <li>3. worn piston or inlet valve</li> <li>4. clogged air filter element</li> <li>5. pressure switch failure</li> <li>6. defective safety valve</li> <li>7. pressure On Valve leaking</li> </ol>	<ol style="list-style-type: none"> <li>1. decrease air usage</li> <li>2. perform leak test &amp; fix as needed (Page 44)</li> <li>3. replace/rebuild compressor</li> <li>4. replace/clean air filter element</li> <li>5. replace pressure switch</li> <li>6. replace safety valve</li> <li>7. deactivate the system, turn all pressures to 0psi, reactivate the system</li> </ol>
Excessive moisture in discharge	<ol style="list-style-type: none"> <li>1. excessive water in the air tank</li> <li>2. high humidity</li> </ol>	<ol style="list-style-type: none"> <li>1. manually drain tank holding down the down arrow on the cab controller</li> <li>2. move compressor to low humidity area</li> </ol>
Compressor will not run	<ol style="list-style-type: none"> <li>1. no power/breaker tripped</li> <li>2. system deactivated</li> <li>3. motor overheats</li> <li>4. pressure switch failure</li> <li>5. on/off solenoid failure</li> <li>6. VDM failure</li> <li>7. compressor failure</li> </ol>	<ol style="list-style-type: none"> <li>1. check power connections/breaker</li> <li>2. press ENTER – AIR ON displayed</li> <li>3. let compressor cool, replace if needed</li> <li>4. replace pressure switch</li> <li>5. replace solenoid</li> <li>6. replace VDM</li> <li>7. replace compressor</li> </ol>
Excessive knocking or rattling	<ol style="list-style-type: none"> <li>1. loose mounting bolts</li> <li>2. worn bearing</li> <li>3. cylinder or piston is worn</li> </ol>	<ol style="list-style-type: none"> <li>1. tighten bolts</li> <li>2. replace compressor</li> <li>3. rebuild compressor</li> </ol>
No air output from the RU, RD, and WT ports even though pressure is commanded and tank pressure reads 60psi or greater	<ol style="list-style-type: none"> <li>1. no power/40A breaker tripped</li> <li>2. system deactivated</li> <li>3. J3 connector on VDM plugged in upside down</li> <li>4. improperly functioning PQE</li> <li>5. communication harness connection issue</li> </ol>	<ol style="list-style-type: none"> <li>1. check power connections/breaker</li> <li>2. press ENTER – AIR ON displayed</li> <li>3. unplug J3 connector, check tab/slot sizes, reinstall J3 connector properly</li> <li>4. replace PQE</li> <li>5. check all communication harness connections, be sure all internal pins seated</li> </ol>
No ECU/VDM present displays on Cab Controller	<ol style="list-style-type: none"> <li>1. improper communication harness connection between Cab Controller and VDM</li> <li>2. VDM failure</li> </ol>	<ol style="list-style-type: none"> <li>1. start at the 6 pin connector on the back of the Cab Controller and inspect all connectors and connections to the VDM</li> <li>2. Replace VDM</li> </ol>
The 2940-162 Dump Valve Harness is not labeled on the 4) 2 pin pigtales	labels missing on the 2 pin cables on the harness	label as follows: RM UP DUMP → Yellow/Black RM DOWN DUMP → Orange/Black AUX 3 → White/Black AUX 4 → Purple/Black
No tank pressure reading on cab controller	pressure transducer failure	<ol style="list-style-type: none"> <li>1. replace pressure transducer</li> <li>2. check pressure transducer connections</li> </ol>
Low or sporadic tank pressure reading Air leaking out regulator knob	water separator/regulator assembly plumbed incorrectly	plumb water separator/regulator correctly (air compressor→water separator→exit regulator side→enter control box inlet port)

## **NOTES:**

## **NOTES:**



A Tradition of Solutions since 1930

Yetter Farm Equipment Co

PO BOX 358 109 S. McDonough

Colchester, IL 62326-0358

Phone: 309-776-4111

Toll Free: 800-447-5777

Email: [info@yetterco.com](mailto:info@yetterco.com)

For updated models and manuals visit the Yetter website:

[www.yetterco.com](http://www.yetterco.com)

© Yetter Farm Equipment Co. All Rights Reserved

2565-773\_REV\_G • 07/2021