

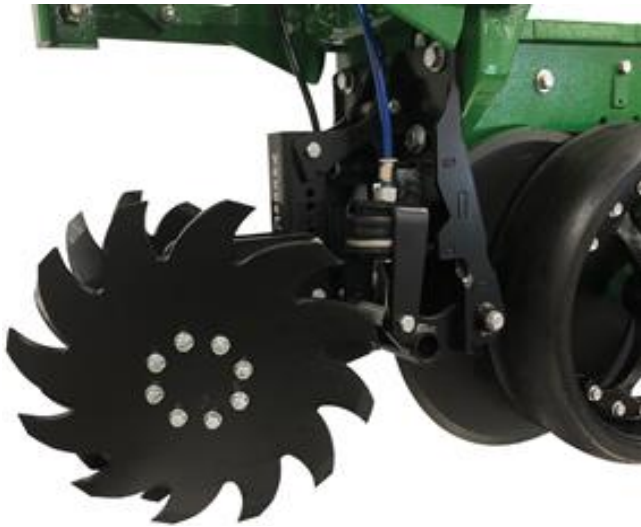

2940 AIR ADJUST RESIDUE MANAGER

OPERATOR'S MANUAL
PART IDENTIFICATION
2565-983_REV_C • 02/2023



*Patented

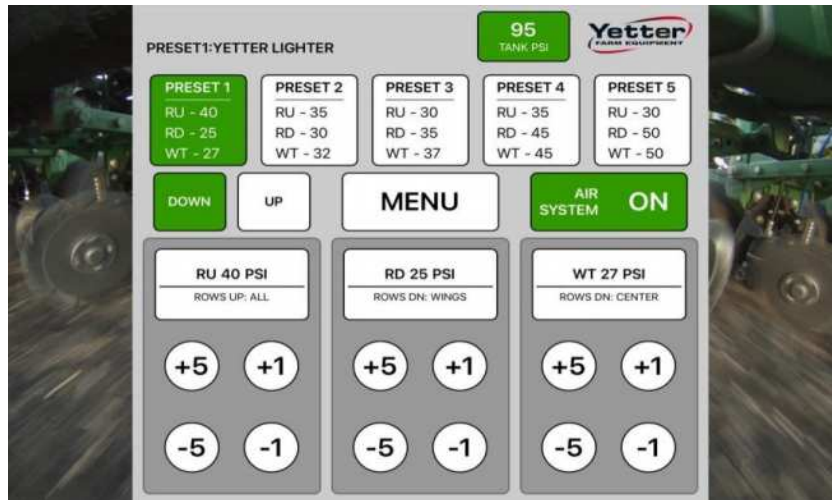

YETTER MANUFACTURING CO.
FOUNDED 1930

Colchester, IL 62326-0358
Toll free: 800/447-5777
309/776-3222 (Fax)
Website: www.yetterco.com
E-mail: info@yetterco.com
serviceteam@yetterco.com

GERMINATE UNIFORMITY™



TABLE OF CONTENTS

Bolt Torque.....	2
Safety.....	4
Hydraulic Fittings Chart.....	5
Components, Kits, and Part Numbers.....	6 – 9
Introduction & System Requirements.....	10
System Information.....	11 – 15
Installation Guide.....	16 – 19
Residue Manager Installation.....	20 – 22
Residue Manager/Coulter Combo Installation.....	23
Tablet Mount / Power Harness	24
2940-103A Control Box Installation.....	25
2940-415 Water Separator/Regulator Assembly Installation.....	25
ISOBUS Installation.....	26
Yetter Compressor Installation.....	27 – 30
Compressor to Control Box Airline Installation.....	31 – 32
Airline Installation.....	32 – 47
Operation.....	48 – 54
Maintenance.....	55 – 56
Parts Identification.....	57 – 77
Troubleshooting.....	78

BOLT TORQUE

Regularly inspect each residue manager for loose or worn bolts & hardware. Repair or replace as needed.



All hardware used on the 2940 Air Adjust is Grade 5 unless otherwise noted. Grade 5 cap screws are marked with three radial lines on the head. If hardware must be replaced, be sure to replace it with hardware of equal size, strength and thread type. Refer to the torque values chart when tightening hardware.



Important: Over tightening hardware can cause as much damage as when under tightening. Tightening hardware beyond the recommended range can reduce its shock load capacity.

The chart below is a guide for proper torque. Use it unless a specified torque is called out elsewhere in the manual. Torque is the force you apply to the wrench handle or the cheater bar, times the length of the handle or bar. Use a torque wrench whenever possible.

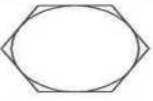
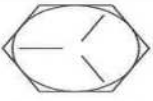
The following table shows torque in ft. lbs. for coarse thread hardware.

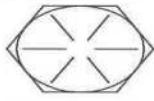
BOLT DIA. AND THREADS PER INCH		 OR 	
	GRADE 2	GRADE 5 A-325	GRADE 8
3/8-16	25	35	50
7/16-14	35	55	80
1/2-13	55	85	125
9/16-12	75	125	175
5/8-11	105	170	235
3/4-10	185	305	425
7/8-9	170	445	690
1-8	260	670	1030
1 1/8-7	365	900	1460
1 1/4-7	515	1275	2060
1 3/8-6	675	1675	2700
1 1/2-6	900	2150	3500
1 3/4-5	1410	3500	5600

FOREWORD

You've just joined an exclusive but rapidly growing club.

For our part, we want to welcome you to the group and thank you for buying a Yetter product.

We hope your new Yetter products will help you achieve both goals-increase your productivity and increase your efficiency so that you may generate more profit.

This operator's manual has been designed into four major sections: Foreword, Safety Precautions, Installation Instructions and Parts Breakdown.



This **SAFETY ALERT SYMBOL** indicates important safety messages in the manual. When you see this symbol, be alert to the possibility of **PERSONAL INJURY** and carefully read the message that follows.

The word **NOTE** is used to convey information that is out of context with the manual text. It contains special information such as specifications, techniques and reference information of a supplementary nature.

The word **IMPORTANT** is used in the text when immediate damage will occur to the machine due

to improper technique or operation. Important will apply to the same information as specified by note only of an immediate and urgent nature.

It is the responsibility of the user to read the operator's manual and comply with the safe and correct operating procedure and to lubricate and maintain the product according to the maintenance schedule in the operator's manual.

The user is responsible for inspecting his machine and for having parts repaired or replaced when continued use of the product would cause damage or excessive wear to the other parts.

It is the user's responsibility to deliver his machine to the Yetter dealer who sold him the product for service or replacement of defective parts, which are covered by the warranty policy.

If you are unable to understand or follow the instructions provided in this publication, consult your local Yetter dealer or contact:

YETTER MANUFACTURING CO.

309/776-4111

800/447-5777

309/776-3222 (FAX)

Website: www.yetterco.com

E-mail: info@yetterco.co

WARRANTY

Yetter Manufacturing warrants all products manufactured and sold by it against defects in material. This warranty being expressly limited to replacement at the factory of such parts or products as shall appear to be defective after inspection. This warranty does not obligate the Company to bear cost of labor in replacement of parts. It is the policy of the Company to make improvements without incurring obligations to add them to any unit already sold. No warranty is made or authorized to be made, other than herein set forth. This warranty is in effect for one year after purchase.

DEALER: _____

Yetter Manufacturing warrants its own products only and cannot be responsible for damages to equipment on which mounted.

SAFETY

A brief description of signal words that may be used in this manual:

CAUTION: Used as a general reminder of good safety practices or to direct attention to unsafe practices.

WARNING: Denotes a specific potential hazard.

DANGER: Denotes the most serious specific potential hazard.

SAFETY PRECAUTIONS

You can make your farm a safer place to live and work if you observe the safety precautions given. Study these precautions carefully and insist that those working with you and for you follow them.

Finally, remember this: an accident is usually caused by someone's carelessness, neglect or oversight.



WARNING

Never clean, lubricate or adjust a machine that is in motion. Always lower or block the implement using the hydraulic cylinder stops before performing service.

If the machine must be serviced in the raised position, jack or block it up to prevent it from accidentally falling and injuring someone.

Do not allow riders on the tractor or implement.

Use speeds and caution dictated by the terrain being traversed. Do not operate on any slope steep enough to cause tipping or loss of control.

Be sure all personnel are clear of the immediate area before operating.

Read and understand the operator's manual and require all other persons who will operate the equipment to do the same.

Be familiar with all tractor and implement controls and be prepared to stop engine and implements quickly in an emergency.



CAUTION

Consult your implement and tractor operator's manual for correct and safe operating practices.

Beware of towed implement width and allow safe clearance.



FAILURE TO HEED MAY RESULT IN PERSONAL INJURY OR DEATH.

Hydraulic Fittings Identification Chart

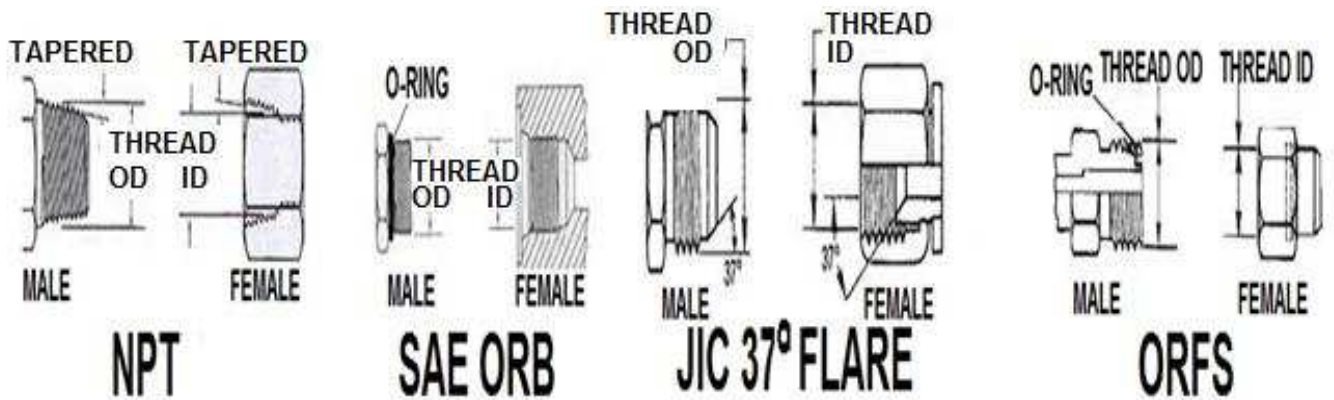

Nominal Size	Dash Size	Nominal Thread	Male Thd OD	Female Thd ID	Nominal Thread	Male Thd OD	Female Thd ID	Nominal Thread	Male Thd OD	Female Thd ID	Nominal Thread	Male Thd OD	Female Thd ID
1/8	02	1/8-27	0.41	0.38	5/16-24	0.31	0.27	5/16-24	0.31	0.27	NOT AVAILABLE		
3/16	03	NOT AVAILABLE			3/8-24	0.38	0.34	3/8-24	0.38	0.34	NOT AVAILABLE		
1/4	04	1/4-18	0.54	0.49	7/16-20	0.44	0.39	7/16-20	0.44	0.39	9/16-18	0.56	0.51
5/16	05	NOT AVAILABLE			1/2-20	0.50	0.45	1/2-20	0.50	0.45	NOT AVAILABLE		
3/8	06	3/8-18	0.68	0.63	9/16-18	0.56	0.51	9/16-18	0.56	0.51	11/16-16	0.69	0.63
1/2	08	1/2-14	0.84	0.77	3/4-16	0.75	0.69	3/4-16	0.75	0.69	13/16-16	0.82	0.75
5/8	10	NOT AVAILABLE			7/8-14	0.88	0.81	7/8-14	0.88	0.81	1-14	1.00	0.93
3/4	12	3/4-14	1.05	0.98	1 1/16-12	1.06	0.98	1 1/16-12	1.06	0.98	1 3/16-12	1.19	1.11
7/8	14	NOT AVAILABLE			1 13/16-12	1.19	1.10	1 13/16-12	1.19	1.10	NOT AVAILABLE		
1	16	1-11 1/2	1.32	1.24	1 5/8-12	1.31	1.23	1 5/8-12	1.31	1.23	1 7/16-12	1.44	1.36
1 1/4	20	1 1/4-11 1/2	1.66	1.58	1 5/8-12	1.63	1.54	1 5/8-12	1.63	1.54	1 11/16-12	1.69	1.61
1 1/2	24	1 1/2-11 1/2	1.90	1.82	1 7/8-12	1.88	1.79	1 7/8-12	1.88	1.79	2-12	2.00	1.92
2	36	2-11 1/2	2.38	2.30	2 1/2-12	2.50	2.42	2 1/2-12	2.50	2.42	NOT AVAILABLE		

- Due to common threads, mismatching can happen and could result in leaks and pressure loss
- Be sure to verify which style and use dash sizes when ordering replacement parts

Thread Styles

-NPT is easily recognizable as tapered National Pipe Thread. It is not recommended for hydraulic systems but does exist on some agriculture equipment. Teflon tape is required.

-SAE ORB is recommended by the NFPA for optimal leakage control in medium and high pressure hydraulic systems. The male fitting has a straight thread and O-ring. The female port has a straight thread, a machined surface (minimum spot face) and a chamfer to accept the O-ring. The seal takes place by compressing the O-ring in the chamfer. The threads hold the connection mechanically.

-JIC 37 Degree Flare fittings have a 37° cone seat on the female adapter and a 37° flare on the male adapter. This cone seat and flare allows for a complete mechanical seal between the male and female fitting. Teflon tape on threads is not required.

-ORFS (O-Ring Face Seal) adapter fittings use a straight thread and have a machined groove in the face of the male fitting to accept the O-ring. This O-ring is compressed against the flat face of the female fitting for a leak proof connection. ORFS are one of the newest types of hydraulic fittings.

Components, Kits, Accessories, & Ordering Numbers

Residue Manager Kits

2940-001B	Pneumatic Residue Manager (RM) Assembly: choice of ST, STF, or BW wheel kit (JD 1700 & 7200, White 9000)
2940-002B	Pneumatic Narrow RM Assembly: choice of ST, STF, or BW wheel kit (JD 1700 & 7200, White 9000)
2940-003B	Pneumatic RM Assembly: choice of ST, STF, or BW wheel kit (CNH 800 – 1200)
2940-004B	Pneumatic Narrow RM Assembly: choice of ST, STF, or BW wheel kit (CNH 800 – 1200)
2940-005B	Pneumatic RM Assembly: choice of ST, STF, or BW wheel kit (JD 7000, White 6000 & 8000, Kinze 2000, 3000, & 4900)
2940-006B	Pneumatic Narrow RM Assembly: choice of ST, STF, or BW wheel kit (JD 7000, White 6000 & 8000, Kinze 2000/3000/4900)
2940-007B	Pneumatic RM/Coulter Combo: choice of ST, STF, or BW wheel kit & coulter blade (JD 7000, White 6000 & 8000, Kinze)
2940-010B	Pneumatic RM/Coulter Combo: choice of ST, STF, or BW wheel kit & coulter blade (JD 1700 & 7200, White 9000)
2940-018	Coulter Less RM Less Blade for JD 7000, Agco 6000 & 8000, Kinze 2000, 3000, & 4900
2940-019	Coulter Less RM Less Blade for JD 1700, 7200, Agco 9000

Control Box, Compressors, Air Lines, & Wiring Kits

2940-050A	Pneumatic Compressor Kit Electric
2940-053A	Pneumatic Control Box (3 Pneumatic Output Controls)
2940-055	Pneumatic Compressor Kit Hydraulic
2940-072A	Split Row Kit
2940-075A	6, 8, & 12 Row Non ISOBUS Hydraulic Wiring and Tubing Kit
2940-076A	16 Row Non ISOBUS Hydraulic Wiring and Tubing Kit
2940-077A	24 Row Non ISOBUS Hydraulic Wiring and Tubing Kit
2940-078A	32, 36, 48, & 54 Row Non ISOBUS Hydraulic Wiring and Tubing Kit

Mounting Kits

2940-082	5X7 and 7X7 Bar Mount Kit (for 2940-103 Control Box)
2940-083	8X16 and 8X12 Bar Mount Kit (for 2940-103 Control Box)
2940-084	Universal Hand Rail Mount Kit (for 2940-103 Control Box)
2940-085	Two Point or Universal Hydraulic Compressor Mount Kit
2940-086	Draft Tube or Universal Hydraulic Compressor Mount Kit
2940-090	8X12 Bar Hydraulic Compressor Mount Kit
2940-091	8X16 Bar Hydraulic Compressor Mount Kit
2940-111	RAM Tablet Mount, 9"-10" Tablet size

Part Numbers & Descriptions

2940-049A	Air Adjust Mount Extension Kit (For JD Planters with HD scrapers)
2940-059	CNH Adaptor Kit for 1260/1265 Planters (20" – 22" spacing) for locking up lift wheels
2940-060	CNH Adaptor Kit for 1260/1265 Planters (30" spacing) for locking up lift wheels
2940-087A	ISOBUS Kit (Tractor Hitch, Ag Leader RCM 2)
2940-087A-JD	Rear ISOBUS Kit, John Deere
2940-087A-AL	ISOBUS Kit, Ag Leader (2019 & before) RCM 1
2940-088	Hydraulic Hose and Fitting Kit (Planter)
2940-089	Hydraulic Hose and Fitting Kit (Stand Alone)
2940-092	Drop Down Kit (for 2940-007B/010B)
2940-093	2940 Snakehead Extension Kit



2940-101A Electric Compressor Unit-----→
 ←-----2940-103A Control Box for Hydraulic Compressors



2940-106 Hydraulic Compressor Unit-----→
 ←-----2940-112A VDM 12 Volt Controller, MIDAC



2940-653 JCA Thrasher Module-----→



←-----2940-111 RAM Tablet Mount Kit

2940-114 Stand Alone Comp Control Kit-----→
 2940-123A Hydraulic Manual Kit (Yetter Monitor)
 2940-126A Pneumatic Combo Sub-Assembly (2940-010A)
 2940-128 Mounting Bolt Bag – 2940-007A & 2940-010A
 2940-130A Pneumatic Combo Sub-Assembly (2940-007A)
 2940-142 Mounting Bolt Bag-2940-001A, 002A, 005A, & 006A
 2940-145 Mounting Bolt Bag-2940-003A & 2940-004A
 2940-147 Package of 10 Tees-----→



←-----2940-148 Package of Zip Ties (100)

2940-150 Main Power Cable with 80A Breaker-----→













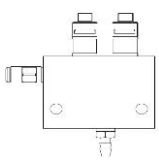

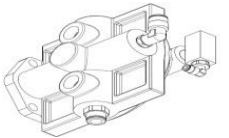
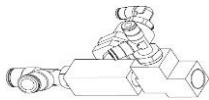





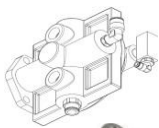





Components, Kits, Accessories, & Ordering Numbers

	←-----2940-151	10 ft. Main Power Cable Extension	
	2940-153A	IGN/GRD Supply Harness, 15ft-----→	
	←-----2940-154	30 ft. Dump Valve Harness Black(Used on Stand Alone Compressor Only)	
	2940-163	20 ft Main Power Extension-----→	
	←-----2940-164A	5 ft. AUX to Air Harness	
	2940-165A	10 ft. AUX to Air Harness	
	2940-166	VDM Power Cable with 40 Amp Breaker-----→	
	←-----2940-167	10 ft. VDM Power Cable Extension	
	2940-168	20 ft. VDM Power Cable Extension	
	2940-170A	10 ft. AUX to Air Harness Extension -----→	
	2940-171A	30 ft. AUX to Air Harness Extension	
	2940-174	Spare Fitting Bag	
	←-----2940-181	Hyd. Compressor Solenoid/Switch Harness	
	2940-182	20Ft Hyd. Compressor Control Harness-----→	
	2940-183	Hardware Bolt Bag for 2940-083 kit	
	2940-184	Hardware Bolt Bag for 2940-084 kit	
	2940-185	Hardware Bolt Bag for 2940-085 kit	
	2940-186	Hardware Bolt Bag for 2940-086 kit	
	2940-189	10Ft Hyd. Compressor Control Harness	
	←-----2940-190A	Pneumatic RM Assembly (2940-001A – 004A)	
	2940-192A	Pneumatic RM Assembly (2940-005 A – 006A)	
	2940-209	CNH Adaptor Bracket (1260/1265 models) --→	
	←-----2940-215	Air Adjust Wide Stem W.A.	
	2940-216	Air Adjust Narrow Stem W.A. -----→	
	←-----2940-337	3/8 Push to Connect (PTC) elbow 1/8 NPT	
	2940-338	3/8 Push Connect Tee-----→	
	←-----2940-341	Air Tubing Cutter	
	2940-342	Ball Valve -----→	
	←-----2940-345	Black 3/8 Air Tubing 100ft rolls	
	2940-346	Blue 3/8 Air Tubing 100ft rolls-----→	
	←-----2940-352	3/8 PTC Plug (package of 5)	
	2940-357	Extreme Air Magnum Rebuild Kit-----→	
	←-----2940-358	3/8 PTC Union, Straight	
	2940-367	25ft Roll 250psi Working Pressure Tubing--→	
	←-----2940-374	Tee-1)1/4"NPT male, 2)1/4"NPT female	
	2940-376	Updated Water Separator Drain Valve Kit--→	
	←-----2940-377	Hydraulic Compressor Pressure Switch (125psi-145psi)	

Components, Kits, Accessories, & Ordering Numbers

	2940-379	PQE Inlet Elbow ¼ NPT to 3/8PTC----->	
	←-----2940-380	3/8PTC X 1/8BSPP O-ring Straight Fitting	
	2940-381	3/8PTC X 1/8BSPP O-ring Elbow Fitting--->	
	←-----2940-382	Shop Air Adapter	
	2940-383	3/8 PC WYE Fitting----->	
	←-----2940-386	Shorter Air Bag	
	2940-388	Larger Air Bag----->	
	←-----2940-390	Extreme Air Magnum Compressor & Filter	
	2940-391	100 AMP Compressor Relay, Continuous-->	
	←-----2940-392	1-Way Check Valve	
	2940-395	Replacement Filter Element (Electric)----->	
	←-----2940-404	Pressure Regulator (part of the 2940-415)	
	2940-408	3/8PTC Elbow Fitting 1/4NPT----->	
	←-----2940-414	3/8PTC X 1/4NPT Straight Fitting	
	2940-415	Water Separator/Regulator Assembly----->	
	←-----2940-416	175PSI Tank Safety Relief Valve	
	2940-430A	20 ft. Aux to Air Harness Extension----->	
	←-----2940-439	0 – 160psi Hydraulic Compressor Gauge, 1/4NPT	
	2940-441A	Pressure Transducer----->	
	←-----2940-506	Hyd. Comp. Solenoid Coil Only	
	2940-519A	Hydraulic Compressor Fan, CAST----->	
	←-----2940-531	Rubber Spider Insert for Love Joy Coupler	
	2940-543	Hyd. Comp. Cartridge Valve (no solenoid)----->	
	←-----2940-544	Hyd. Pressure Gauge (0 – 5000psi)	
	2940-545	Rol-Air Compressor Pump Unit----->	
	←-----2940-546	Hydraulic Control Block	
	2940-547	Hyd. Compressor Gasket Kit----->	
	←-----2940-636	Hydraulic Motor Seal Kit (GRH)	
	2940-549	Hydraulic Compressor Air Filter----->	
	←-----2940-550	Rol-Air Synthetic Compressor Oil 1Liter	

Components, Kits, Accessories, & Ordering Numbers

	2940-554	Hyd. Comp. Motor----->	
	←-----2940-609	45 Degree Air Fitting 3/8PC X 1/8NPT	
	2940-635	3/8 PTC X 3/8 NPT 90 Degree Swivel ----->	
	←-----2940-637	Valve Assembly	
	2940-638	Inlet Assembly ----->	
	←-----2940-639	Quick Exhaust Assembly (fittings included)	
	2940-640	Mac BV Valve 2-Way----->	
	←-----2940-641	10-32 to 1/4 Tube Barb Fitting	
	2940-642	10-32 to 5/32 Tube PTC Fitting----->	
	←-----2940-643	1/4 Tube Orifice	
	2940-644	1/4 NPT Tee ----->	
	←-----2940-645	Pilot Operated Regulator (fittings not included)	
	2940-646	1/4"NPT Street Elbow----->	
	←-----2940-647	1/4"NTP to 5/32 Run Tee	
	2940-648	1/4"NPT Bulkhead ----->	
	←-----2940-649	1/4"NPT to 3/8 Run Tee	
	2940-650	1/4"NPT to 1/4 Tube PTC Elbow Fitting----->	
	←-----2940-651	5/32 Tubing	
	2940-652	12" X 14" X 8" Enclosure ----->	
	←-----2966-293	CNH Adaptor Bracket	
	1200-337	1/4 Airline, 100ft roll ----->	
	←-----2940-654	Thrasher to Midac Harness	
	2940-655	Control Box ISOBUS Harness----->	
	←-----2940-656	ISOBUS Hitch Harness	
	2940-657	ISOBUS Extension Harness, 15ft----->	
	2940-658	ISOBUS Extension Harness, 30ft	
	←-----2940-659	JD ISOBUS Adapter Harness	
	2940-660	Terminator Harness----->	
	←-----2940-661	Ag Leader Harness, Yetter Control Box	
	2940-662	Ag Leader Harness, Planter Control Module----->	
	2940-670	Midac Control Harness (Harness inside 2940-103A	
	2940-676	15ft Thrasher to Midac Extension Harness	

Introduction

The Yetter Air Compressor converts hydraulic or electric power into compressed air. Yetter Compressor units are durably constructed and designed for easy integration to operate the Yetter 2940 Air Adjust System. The Yetter Air Compressors build 145psi, the 2940-415 Water Separator/Regulator assembly allows 100-120psi of clean, dry air to enter the 2940-103A Control Box & as the operator commands pressure on the cab controller, the row cleaners adjust on the go with no planting delay or downtime leading to more planting hours per day. The precise adjustments give the row units & planter a more even ride leading to more accurate seed placement & seed depth resulting in even emergence. **IF USING THE YETTER COMPRESSOR TO SUPPLY AIR TO OPERATE ANOTHER PNEUMATIC SYSTEM, INSTALL A REGULATOR PRIOR TO AIR ENTERING THAT SYSTEM WITH THE PROPER REGULATED AIR SETTINGS RECOMMENDED BY THE OEM PRODUCT.**

System Requirements

Hydraulic Compressor

- Requires 4 gallons per minute maximum hydraulic flow to operate. 12CFM @ startup, 8.1CFM @ 90psi. 12 gallon storage tank.

- Lubrication of the pump requires a FULL synthetic or PAO synthetic compressor oil. **THE PUMP IS SHIPPED EMPTY & NEEDS OIL BEFORE OPERATING! SEE PAGE 27 FOR FILLING DETAILS!**

- Hydraulic oil flow is required to operate the hydraulic compressor's hydraulic motor. Different variables will determine the best way to connect into a hydraulic circuit to power the hydraulic motor. Connecting directly to a tractor's open SCV port, teeing into the planter frame lift/lowering circuit, or teeing into the bulk tank blower circuit are examples of supplying hydraulic flow to the compressor. Check OEM tractor and planter manual for hydraulic GPM output to make sure an adequate source is selected. If plumbing into a planter circuit, plumb between the tractor SCV and the hydraulic block usually located under the bulk fill tanks. The planter circuit that is plumbed into must have constant hydraulic flow. **PTO DRIVEN AND POWER BEYOND HYDRAULIC CIRCUITS ARE NOT AN ADEQUATE SOURCE TO OPERATE THE YETTER HYDRAULIC COMPRESSOR!**

- Case Drain connection is required to carry the motor case internal leakage directly to the tractor hydraulic reservoir (sump) with zero pressure. This oil serves to lubricate and cool motor components not directly exposed to the working oil. It is normal to have seepage from this fitting when disconnected from the tractor to protect the motor seals from thermal expansion. Plumb the case drain so that hydraulic oil returns to the same reservoir used for the pressure and return. If the tractor is not equipped with a female flat face case drain coupler, then a Case Drain Kit must be sourced through a dealer or hydraulic supplier. **DO NOT PLUMB THE CASE DRAIN OF THE HYDRAULIC COMPRESSOR INTO A RETURN CIRCUIT!**

Electric Compressor

- Uses 12V from tractor battery that has an implemented 80A breaker & 4 gauge power cables. **NO MORE THAN 50FT OF POWER CABLES SHOULD BE USED UNLESS LARGER GAUGE CABLES ARE MADE.** Low voltage detection is integrated in the Yetter system.

- 6CFM @ 0psi, 2.6CFM @ 100psi. 12 gallon storage tank.

- OEM ELECTRIC COMPRESSORS ON PLANTERS ARE NOT AN ADEQUATE SOURCE OF AIR TO OPERATE THE YETTER 2940 AIR ADJUST SYSTEM!

Power Supply

The 2940-103A Control Box uses the tractor's switched power source & battery power. Battery power cables are 8 gauge & a 40A breaker is implemented. The 2940-153A will need connected to a switched power source. **THE CIGARETTE LIGHTER POWER SOURCE IS NOT A SWITCHED POWER SOURCE AND SHOULD NOT BE USED!**

SWITCHED POWER SOURCE CONNECTOR PART #'S: (Connector to the tractor not included)

JOHN DEERE P/N: RE67013

CNH P/N: 187103A1

CAT P/N: AG233356

The 2940-112A VDM (Valve Drive Module) inside the 2940-103A Control Box uses 12V from the tractor battery.

Fuse Protection

To protect the VDM inside of the 2940-103A Control Box from damage always ensure the integrity of the integrated 40 amp breaker on the 2940-166 where connected to the tractor battery in case of short or over-circuit. Electric Compressors also use an additional 80 amp breaker. When connected correctly, the tractor has a fuse to protect switched power supply, located in the tractor's fuse panel.

Compressor Maintenance

To prolong the life expectancy of Yetter compressors or OEM hydraulic compressors, clean filter **DAILY** during use by removing the element from the filter housing, & tapping it, exposed side down. This will empty the pleats of filter of collected dust. If dust has been wet or will not clean out, call Yetter to order a new element, part # 2940-549 for hyd. compressors & 2940-395 for electric compressors, or if using an OEM hydraulic compressor, call your local dealer. You may lightly blow out the compressor housing using a blow gun, however, **DO NOT** blow out filter element. The housing and filter should be cleaned **DAILY** during field operation, or more if conditions are very dusty. Hydraulic compressors create a good amount of moisture & should be drained on a daily basis when in use. **See pages 55 – 56 for further maintenance.**

2940 Air Adjust System Information

The 2940 Air Adjust Residue Manager control system consists of five primary components and kits; Residue Manager(RM) or RM/Coulter Combo Kit, Tablet or ISOBUS controller, Yetter Air Compressor Assembly (unless plumbing into an OEM hydraulic compressor), Control Box Kit, & the Harnessing, Air Lines, & Fittings Kit.

Residue Manager

RM/Coulter Combo

Each of these kits will include the required brackets, wheel assemblies, & mounting hardware for installation to the row unit.

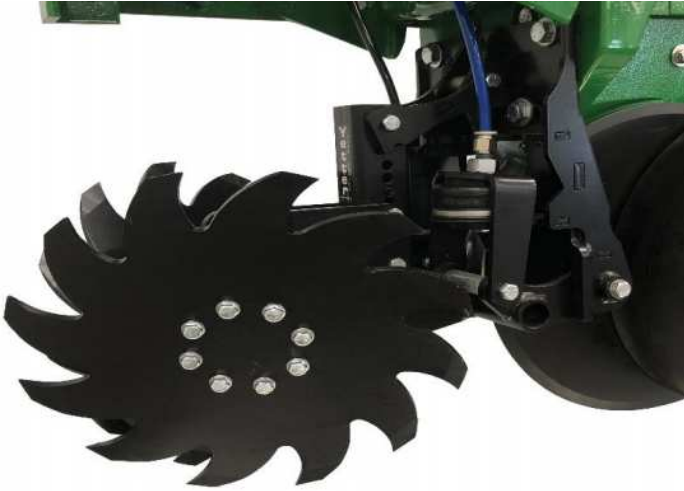

Tablet (NOT SUPPLIED)

The Tablet of choice, not supplied, will use the 2940-111 RAM mount for 9 – 10” tablets provided for installation in cab. If a larger Tablet size is used, sourcing a larger RAM Tablet Mount will be necessary. RAM-HOL-UN11U can be purchased online for tablets 11 – 12”. Go into the tablets App Store, search for Yetter Air Adjust, & download the App. Once the system is installed, turn the key to make sure the 2940-653 Thrasher module’s indicator lights come on. Once the indicator lights are on, go into the tablets WiFi settings & connect to AIR ADJUST. Open the Yetter App & you should be taken to the Activation Screen. Press the ACTIVATE SYSTEM icon & you will be taken to the operating screen. Until the compressor has built a minimum of 75psi, no pressure will be sent to the air bags. Let the compressor go thru 1 complete cycle & shut off before applying air to the air bags. Using shop air with the 2940-382 adapter is an alternative method way to supply air to the system to help prolong the service life on Yetter compressors.

RAM Mount



Tablet Operating Screen

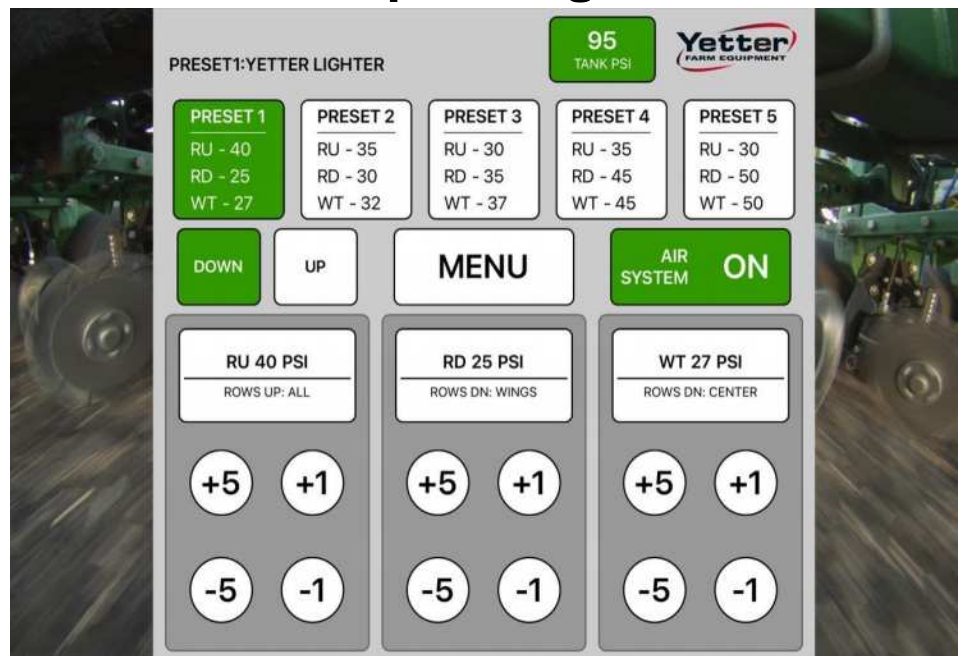

2940 Air Adjust System Information

Air Compressor Assembly



2940 Air Adjust requires a stable air supply source that can provide a minimum of 75psi of clean, dry air. The 'clean, dry air' is a key component of the air supply, moisture within the air supply can shorten the life cycle of the system. Yetter compressors should build to 145psi on the tank gauge before shutting off. When pressure in the tank drops below 120psi, the compressor will engage to build back up to 145psi. Other pneumatic systems, for example pneumatic down force or air clutches, can be plumbed using the Yetter compressor as its air source. Be sure to regulate the air entering any other systems to OEM specifications.



Electric Compresso External Diagram

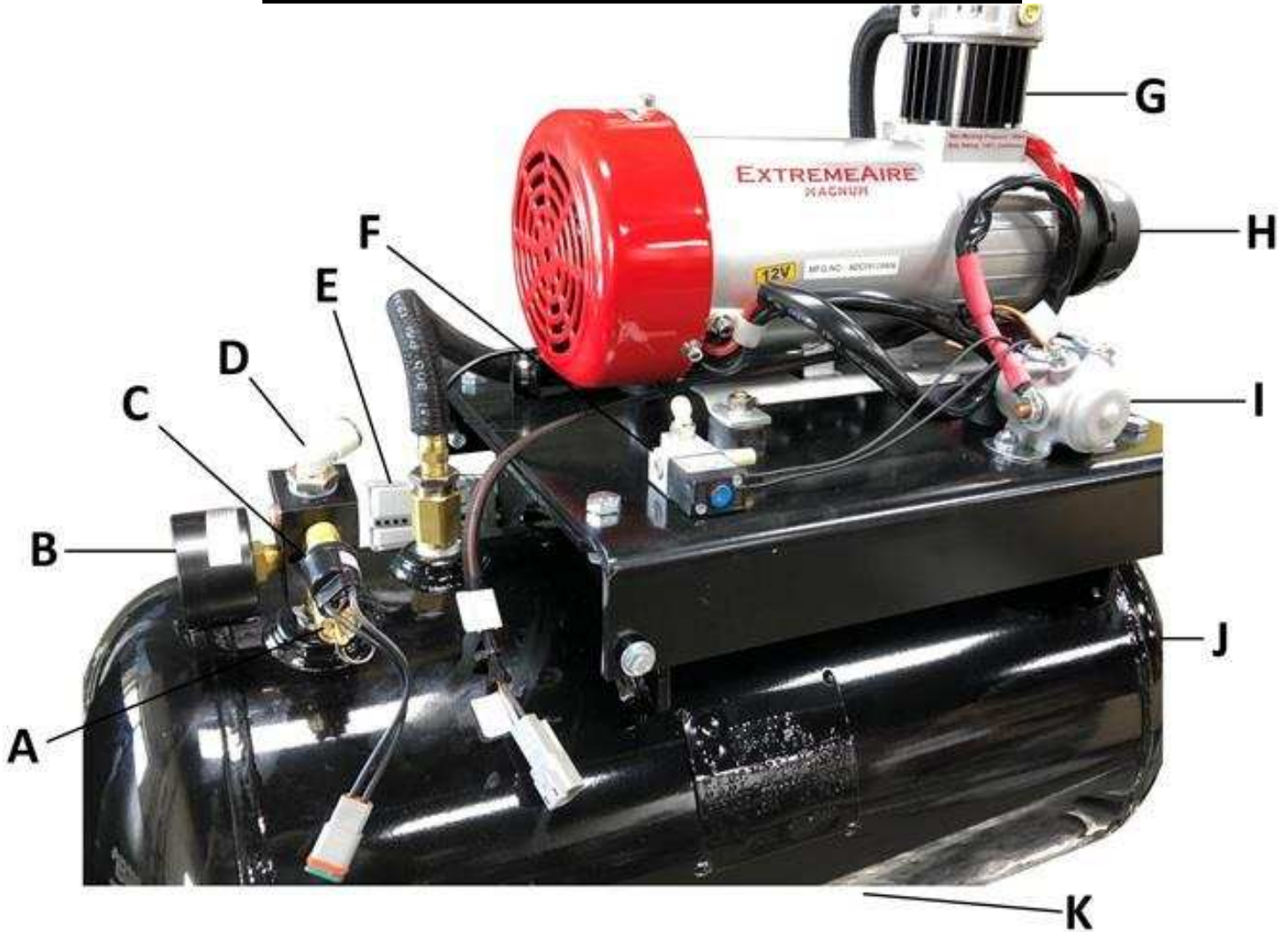

- A – 2940-416 175psi Safety Relief Valve
- B – 2940-439 0 – 160psi Compressor Gauge, 1/4NPT
- C - 2940-377 Pressure Switch 125psi – 145psi
- D – 2940-635 3/8"PTC X 3/8NPT 90° Fitting
- E – No Part # Main Power Connector
- F – 2940-336 Head Pressure Relief Valve

- G – 2940-390 Electric Air Compressor
- H – 2940-395 Replacement Filter Element
- I – 2940-391 100 Amp Compressor Relay
- J – 2940-440 12G Tank Assembly
- K – No Part # Tank Drain Valve
- Not shown** – No part # Enclosure Cage

Hydraulic Compressor External Diagram

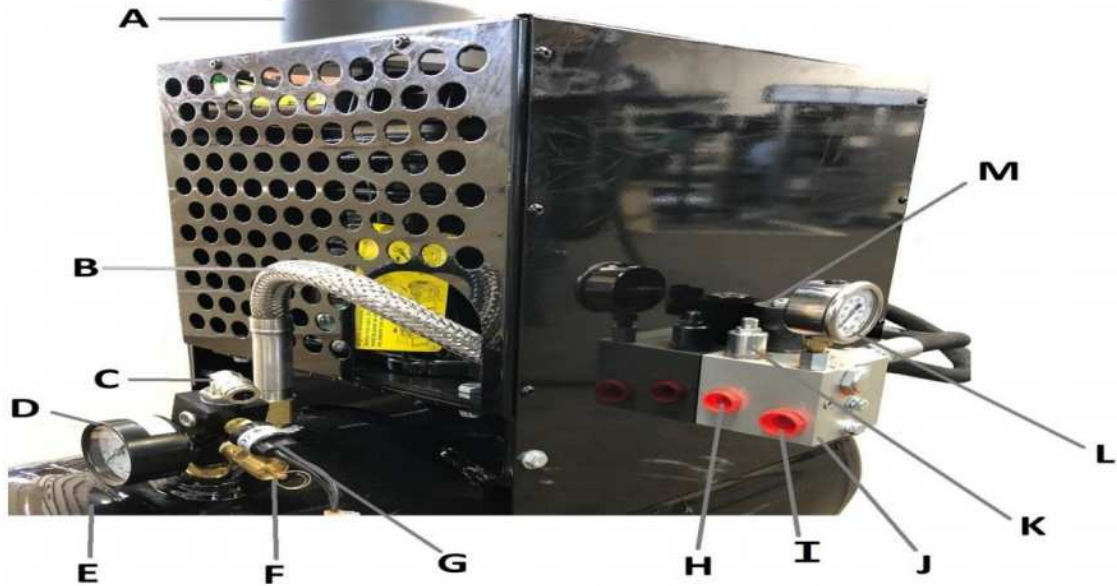

Item	Part Number	Description	Quantity
A	2940-549	Air Filter	1
B	N/A	Compressor Pressure Line	1
C	2940-635	Output Elbow Fitting 3/8PTC 90 Degree 3/8NPT	1
D	2940-439	0-160PSI Tank Pressure Gauge, 1/4NPT	1
E	2940-440	Tank, 12 Gallon	1
F	2940-416	175PSI Safety Relief Valve	1
G	2940-377	Pressure Switch, 125PSI – 145PSI	1
H	N/A	Hydraulic Pressure Port -6 ORFS	1
I	N/A	Hydraulic Return to Tank Inlet Port -6 ORFS	1
J	2940-546	Hydraulic Compressor Control Block	1
K	N/A	Flow Control Valve	1
L	2940-544	0-5000PSI Hydraulic Pressure Gauge	1
M	2940-506	Hydraulic On/Off Valve (COIL ONLY)	1
	2940-543	Hydraulic On/Off Cartridge Valve	1

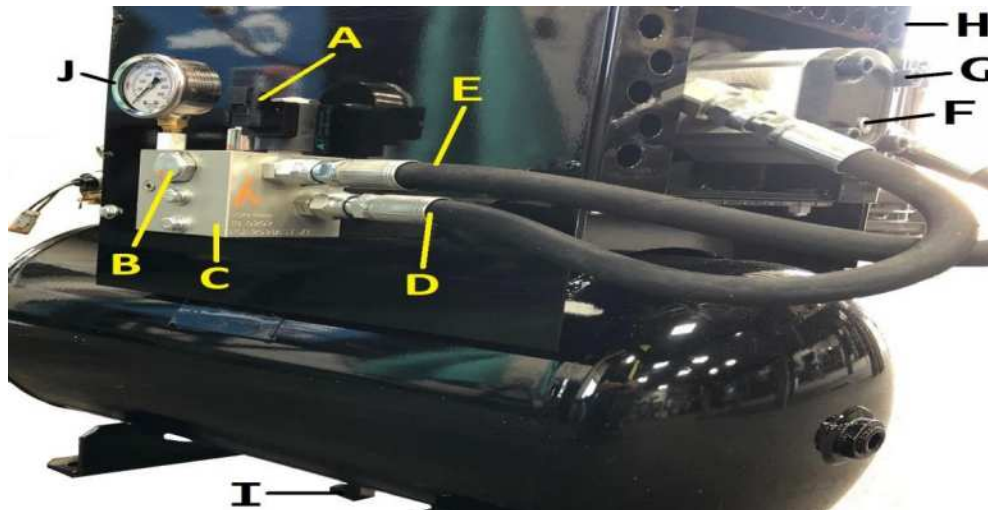

Item	Part #	Description	Quantity
A	2940-506	Hydraulic Compressor Solenoid Coil	1
	2940-543	Hydraulic On/Off Valve (Solenoid)	
B	N/A	Check Valve	1
C	2940-546	Hydraulic Compressor Control Block	1
D	N/A	Pressure Inlet Hose	1
E	N/A	Return to Tank Hose	1
F	N/A	Case Drain Port -4 ORFS	1
G	2940-554	Hydraulic Motor	1
H	N/A	Housing Assembly	1
I	N/A	Tank Drain Valve	1
J	2940-544	0-5000PSI Hydraulic Pressure Gauge	1

Control Box

The 2940-103A control box communicates between the 2940-112A VDM & 2940-653 Thrasher, dispenses air out of quick exhaust regs that are fed by little fill/dump valves as the operator sends commands. The VDM is the valve drive module that is programmed to carry out each function of the system. The Thrasher uses a WiFi signal or ISOBUS to communicate commands by the operator to execute thru the VDM.

2940-103A Control Box External Lay Out

2940-654 – MIDAC TO THRASHER
COMMUNICATION HARNESS

2940-653 – JCA THRASHER MODULE
(MOUNTED ON TOP OF THE BOX)

POWER
HARNESS
CONNECTOR

ISOBUS
CONNECTION

COMPRESSOR
COMMUNICATION

THRASHER TO
VDM
CONNECTOR

2940-408
AIR SUPPLY
INLET ELBOW



WATER
SEPARATOR
OUTLET

WATER
SEPARATOR
INLET

RU – ALL ROWS
UPPRESSURE

RD – WING ROWS
DOWN PRESSURE

WT – CENTER ROWS
DOWN PRESSURE

WHEEL TRACK (WT) DOWN PRESSURE PORT - Safely route black airline from the WT port to the tee in the center section of the planter's down pressure trunk airline. The down pressure on the center section residue managers (RM) or RM/Coulter Combo can be adjusted separately than the wing/outer sections down pressure to make up for tractor/planter tire compaction. WT should be set 2-5 psi heavier than RD. If the WT port is not used, install a plug (2940-352) to prevent air loss.

RESIDUE MANAGER DOWN (RD) PRESSURE PORT - Safely route black airline from the RD port to the open port on each tee installed in the trunk airline on each wing/outer sections of the planter. This port dispenses down pressure to the RM or RM/Coulter Combos on the left & right wing row cleaners on the planter.

RESIDUE MANAGER UP (RU) PRESSURE PORT - Safely route blue airline from the RU port to each tee on each section of the planter's up pressure trunk airline. This port dispenses up pressure to each RM or RM/Coulter Combo on the planter.

WATER SEPARATOR INLET- Install the 1/4" airline from the bottom of the water separator into this port.

WATER SEPARATOR OUTLET- Install 1/4" airline in this port, route toward the ground. (drain's condensation from water separator)

MAIN AIR SUPPLY INLET- Plumb the 2940-367 250psi rated 3/8" airline from the hydraulic compressor to the inlet (water trap side) of the water separator/regulator assembly. Plumb 2940-345 3/8" black airline from outlet (regulator side) of the water separator/regulator assembly to this port. Ensure the regulator is set to 100-120psi by reading the gauge.

COMPRESSOR COMMUNICATION – Install the 2940-181 Compressor Solenoid/Switch Harness at the compressor. Use 2940-182 (20FT) &/or 2940-189 (10FT) extension harnesses to reach the control box & install into this port. Used only if application uses a Yetter Hydraulic Compressor. **(see page 29)**

POWER HARNESS CONNECTION - Depending on application, route 2940-164A or 2940-165A AUX PWR cable from rear of the tractor to this female connector. If the control box is mounted at the rear of the planter, 2940-170A, 2940-171A, or 2940-430A AUX PWR extensions will route to this female connector.

2940-654 MIDAC TO THRASHER HARNESS – Connects the communication/power supply from the Midac to the Thrasher

2940-103A Control Box Internal Lay Out

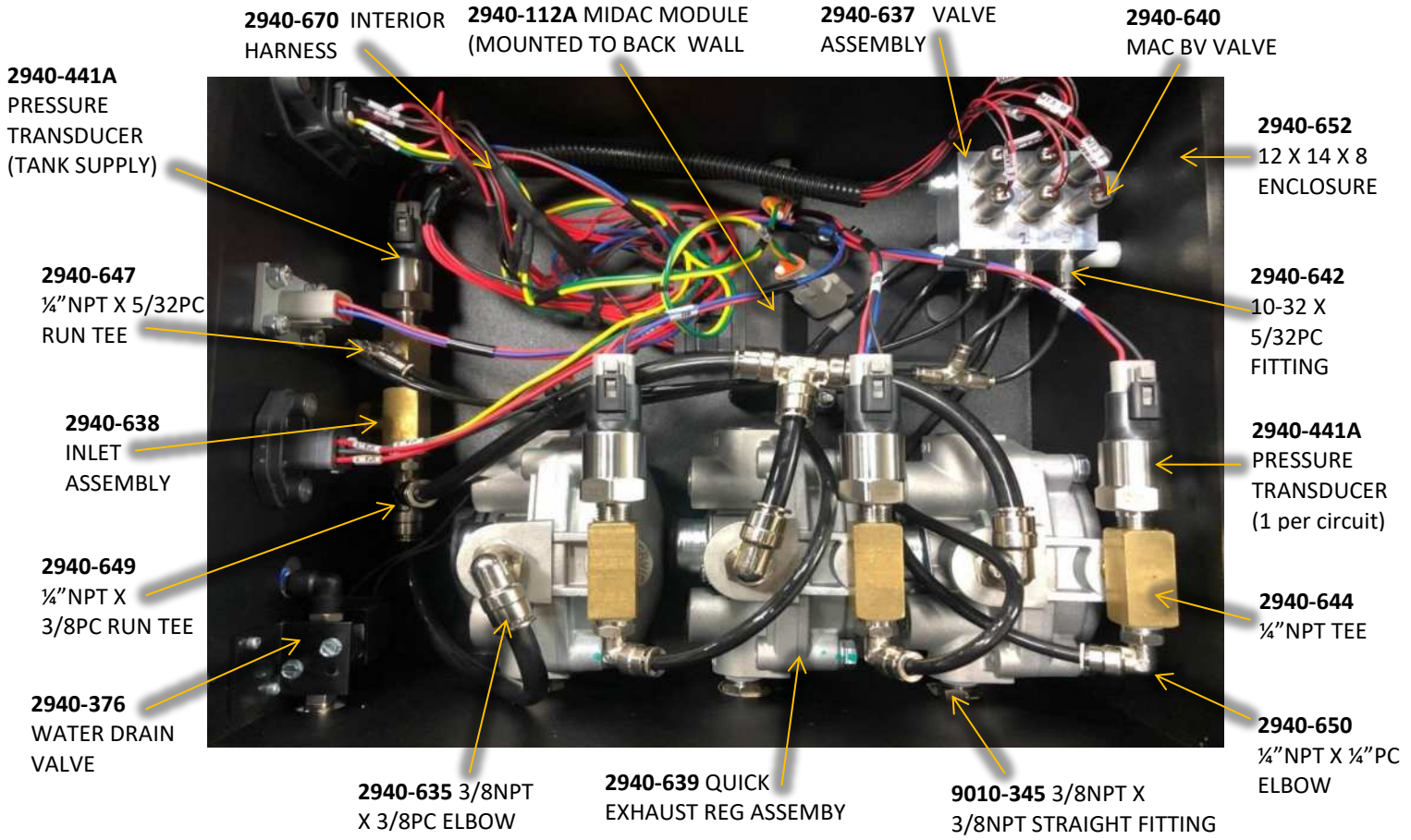

AIR TUBING: 2940-345 3/8 AIRLINE, 100FT ROLL, 1200-337 1/4 AIRLINE, 100FT ROLL, 2940-651 5/32 AIRLINE, 100FT ROLL

Harness, Airlines, and Fittings Kit



12V-DC cables will be used to power the VDM & Thrasher. Flexible tubing will be used to move air from the tank to each air bag. Each kit will include pneumatic lines for both circuits, down and lift, as well as the fittings to make connections and cable ties to securely fasten the lines to the planter. Note: All 2940 Air Adjust kits include a tubing cutter within the kit. **The 2940-341 airline cutter should be used for every cut to ensure a clean, square cut is made.**

Installation Guide Using a Yetter Compressor

***For installation using a John Deere Hydraulic Compressor installation, see page 17, a Precision Planting Hydraulic Compressor, see page 18, or a Case IH Hydraulic Compressor, see page 19.**

STEP 1: RESIDUE MANAGER (RM) OR RM/COULTER COMBO INSTALLATION

Residue Manager Only: Install RM Assemblies securing with mounting hardware. Install wheel mount assembly on the adjustment tube so the top hole of the wheel mount aligns to the 4th or 5th hole down from the top of the adjustment tube for conventional tillage/mellow soils, 5th or 6th hole from the top for no till/minimum till conditions. Install wheels on wheel mounts using hardware from the 2966-119 bolt bag. Install the RM wheels so that the left wheel leads, right wheel trails on the left side of planter; the right wheel leads, left wheel trails on right side of planter.

RM/Coulter Combo: Install the RM/Coulter Combo assembly using hardware from the 2940-128 bolt bag. Mount the coulter blade on the coulter arm hub & mount the RM wheels using the 5/8 Whiz Lock Nuts. RM wheels on combo units will install in the rear holes on both sides on all rows. It is recommended to set the coulter blade at seed depth or above. **Refer to diagram on pages 20 – 23**

STEP 2: TABLET/ISOBUS IN-CAB INSTALLATION

If using a tablet, mount Tablet & 2940-111 RAM Mount in tractor cab. Position Tablet within reach during operation without compromising safety/visibility from cab. The right rear corner post area is recommended so that operator can see performance of residue managers while making adjustments. In both applications, install 2940-153A harness by feeding the bare ends thru the harness access hole into the cab. Bare ends get spliced to plug (not provided) that fits tractor's switched power source, splice red wire on 2940-153A to orange wire & splice black wires together on each harness. Leave the 2 pin connector at the tractor hitch. **Refer to diagram on page 24**

STEP 3: COMPRESSOR & CONTROL BOX INSTALLATION

Control Box Installation: Mount the control box in a safe location with mounts/hardware supplied where the control box can be viewed from the tractor cab. Install the 2940-415 water separator/regulator assembly near the control box. Measure & cut the 2940-367 250psi rated 3/8" airline & install from outlet elbow on the compressor into the 2940-415 inlet (water trap side). Adjust the regulator to allow 100-120psi of air into inlet of control box. Install 3/8" airline from 2940-415 outlet fitting (regulator side) to control box 3/8 inlet fitting. Route provided 1/4" airline from elbow on bottom of 2940-415 to 1/4" PTC fitting on bottom of control box. Route 1/4" airline from 1/4" PTC fitting on the side of control box toward the ground, as airline will dispense moisture. **Refer to diagram on pages 25, 31 – 32**

Compressor Installation: Remove compressor from shipping crate. On Hyd. Compressors, remove the control block & housing to add provided oil to fill line on sight glass of the Rol-Air pump. Reinstall housing & control block after filling with oil. Locate a suitable mounting location for the compressor assembly. Placement of the compressor assembly will vary on the make & model of the planter. Use mounts & hardware supplied or depending on application, **different mounts may need to be built**. Be sure to check clearance of the compressor in the mounting location, noting tractor tires while making turns, markers, & folding/unfolding the planter. **Refer to diagram on pages 27 – 30**

STEP 4: COMPRESSOR & CONTROL BOX HARNESS INSTALLATION

Only on Yetter electric compressor installation, install 2940-150 main power cable/breaker (4 gauge cable, 80A breaker) on tractor battery on the correct terminals, red = positive +, black = negative -. Install 2940-151(10ft) & 2940-163(20ft) power cable extensions as needed between the main power cable/breaker & main power connector on the electric compressor. On all installations, install the 2940-166 VDM power cable with 40A breaker on the tractor battery on the correct terminals, red = positive +, black = negative -. Connect the VDM power extension (2940-167 or 2940-168) & route to the tractor hitch. Install the AUX PWR Harness, 2940-164A or 2940-165A. The 2 pin connects to the 2940-153A from the tractor cab, the Anderson power connector connects to the 8 gauge cable that routes to the battery, & the black male 12 pin Deutsch connector connects to power harness connector on the side of the control box. If the 2940-103A control box is mounted at the back of the planter, 2940-170A (10ft), 2940-171A (30ft), & 2940-430A (20ft) AUX PWR extensions will be needed. Install the 2940-181 Y harness on the Yetter compressor. Install the 2940-182 (20ft, not included) or 2940-189 (10ft, included) control harness from the 4 pin end of the 2940-181 Y harness to the 4 pin connector on the side of the control box. **Refer to diagram on page 24, 28 – 29**

ISOBUS HARNESS (IF APPLICABLE) Install 2940-655 harness to 2940-654 on Yetter control box. Use 2940-657(15ft) & 2940-658(30ft) extensions to reach where ISOBUS is being tied in. On JD planters, use 2940-659 to plug in at back of planter where terminating resistor harness was located. On RCM I Ag Leader systems, plug into ISOBUS connections near center of planter at Planter Control Module using 2940-662 harness. On RCM II Ag Leader systems, route to tractor hitch & plug into back of tractor using 2940-656. **Refer to diagram on page 26**

STEP 5: PLUMBING AIRLINES

A group of airlines that route to residue manager air bags are referred to as trunk airlines. Airline routing from RU, RD, & WT to trunk airline is referred to as a supply airline. Start by routing trunk airlines: route black (down pressure) & blue (up pressure) airline on each wing/side of planter. Start at end row of each wing, route airline to last row on wing & install in air bag, black airline = down pressure air bag, blue airline = up pressure air bag. Follow airline back to end row cutting a tee in each airline at each row. When return back to end row, cut airline to length & install into air bag. Install airline from each tee at each row & install in air bag for that row. If installing on a split row planter, keep trunk airline on front rank residue managers on each wing plumbed separate from back rank. When plumbing in WT (wheel track) rows, use center 4 or 6 rows that plant over the tractor & planter wheel tracks. If equipping on a narrow transport planter with 4 center rows & 6 rows are desired on the WT circuit, tie in the 1 row on each wing/side of the planter closest to the first & last center row. Install a tee in the center of each up pressure trunk airline. Use tees to route/install blue airline from the RU port on control box to each tee in center of each up pressure trunk airline. Install a tee into the down pressure trunk airline on the left wing & right wing. Route/install black airline from the RD port on control box to each tee in center of left & right wing down pressure trunk airline. Install tee in center of center section down pressure trunk airline. Route/install airline from WT port on control box to tee in the center of down pressure trunk airline on center of planter. If planter is dual rank, connect the trunk airline on the corn rows to the trunk airline of the bean rows. Use 2940-342 ball valves between corn row trunk airlines & bean row trunk airlines to be able to shut air supply off to bean rows when planting corn. **Refer to pages 32 – 47**

STEP 6: PERFORM A PRE-OPERATION TEST OF THE SYSTEM

Now that the system is installed, perform a pre-operation test. Start by folding/unfolding & lowering/raising the planter checking for slack in airline & in harnesses at hinge points. Check all electrical connections, cables, & airline making sure nothing was damaged. Next, with the tractor on, connect to the WiFi with your tablet or pull the Yetter screen up on the ISOBUS VT, & press the ACTIVE SYSTEM icon. The compressor will turn on, build to 145psi (100-120psi on the cab controller) & shut off. Check the interior of the control box housing (valve, fittings, & airline) for leaks. Apply 40psi to the RU port & watch your RMs as they should all raise to maximum up travel. Check for leaks on all up pressure circuits & fittings. When that leak check is finished, turn RU to 0psi & turn RD & WT to 40psi. Check all down pressure airline & fittings in these circuits for leaks & repair as needed. **Refer to pages 53 – 54**

***Installation Guide – John Deere Hydraulic Compressor**

STEP 1: RESIDUE MANAGER (RM) OR RM/COULTER COMBO INSTALLATION

Residue Manager Only: Install RM Assemblies securing with mounting hardware. Install the wheel mount assembly on the adjustment tube so the top hole of the wheel mount aligns to the 4th or 5th hole down from the top of the adjustment tube for conventional tillage/mellow soils, 5th or 6th hole from the top for no till/minimum till conditions. Install wheels on wheel mounts using hardware from the 2966-119 bolt bag. Install the RM wheels so that the left wheel leads, right wheel trails on the left side of planter; the right wheel leads, left wheel trails on right side of planter. **RM/Coulter Combo:** Install the RM/Coulter Combo assembly using hardware from the 2940-128 bolt bag. Mount the coulter blade on the coulter arm hub & mount the RM wheels using the 5/8 Whiz Lock Nuts. RM wheels on combo units will install in the rear holes on both sides on all rows. It is recommended to set the coulter blade at seed depth or above. [Refer to diagram on pages 20 – 23](#)

STEP 2: TABLET/ISOBUS IN-CAB INSTALLATION

If using a tablet, mount Tablet & 2940-111 RAM Mount in tractor cab. Position Tablet within reach during operation without compromising safety/visibility from cab. The right rear corner post area is recommended so that operator can see performance of residue managers while making adjustments. In both applications, install 2940-153A harness by feeding the bare ends thru the harness access hole into the cab. Bare ends get spliced to plug (not provided) that fits tractor's switched power source, splice red wire on 2940-153A to orange wire & splice black wires together on each harness. Leave the 2 pin connector at the tractor hitch. [Refer to diagram on page 24](#)

STEP 3: 2940-103A CONTROL BOX INSTALLATION

Mount the control box in a safe location (usually on handrail) with mounts & hardware supplied. Locate the John Deere hydraulic compressor & its pneumatic valve block assembly. Drain all air pressure from the compressor tank & valve block. Locate the plug (next to the yellow valve handle or pressure gauge facing rearward on the valve manifold). Remove the pipe plug if equipped & install a 2940-408 ¼" NPT X 3/8" PC elbow in that port. If equipped with a gauge, remove gauge & install 2940-374 adaptor with 2 female ¼" NPT ends & 1 male ¼" NPT end. Male thread side of Tee installs into valve block, gauge installs onto rearward facing female threads, & 2940-408 elbow installs into remaining female threads (facing upward). Apply Teflon tape to all male threads. Mount the 2940-415 water separator/regulator assembly near control box. Measure & cut 2940-367 250psi rated line from the 2940-408 elbow attached to valve block into the inlet (water trap side) of water separator regulator assembly. Adjust the regulator to only allow 100-120psi of clean, dry air beyond it. Measure & cut black airline from the outlet fitting (regulator side) of water separator/regulator assembly to 3/8" inlet fitting of control box. Route provided ¼" airline from elbow on the bottom of water separator/regulator assembly to ¼" PC fitting on the bottom of control box. Route ¼" airline from ¼" PTC fitting on the side of control box toward the ground, this airline will dispense moisture. [Refer to diagram on pages 25 & 31](#)

STEP 4: CONTROL BOX HARNESS INSTALLATION

Install 2940-166 VDM power cable with 40A breaker on tractor battery on the correct terminals, red = positive +, black = negative -. Connect VDM power extension (2940-167 or 2940-168) & route to tractor hitch. Install the AUX PWR Harness, 2940-164A or 2940-165A. The 2 pin connects to the 2940-153A from tractor cab, Anderson power connector connects to 8 gauge cable that routes to battery, & the black male 12 pin Deutsch connector connects to power harness connector on the side of the control box. If the 2940-103A control box is mounted at the back of the planter, 2940-170A (10ft), 2940-171A (30ft), & 2940-430A (20ft) AUX PWR extensions will be needed. [Refer to diagram on page 24](#)

ISOBUS HARNESS (IF APPLICABLE) Install the 2940-655 harness to 2940-654 on Yetter control box. Use 2940-657 (15ft) & 2940-658 (30ft) extensions to reach where the ISOBUS is being tied in. On JD planters, use the 2940-659 to plug in at the back of planter where terminating resistor harness was located. [Refer to diagram on page 26](#)

STEP 5: PLUMBING AIRLINES

A group of airlines that route to residue manager air bags are referred to as trunk airlines. Airline routing from RU, RD, & WT to trunk airline is referred to as a supply airline. Start by routing trunk airlines: route black (down pressure) & blue (up pressure) airline on each wing/side of planter. Start at end row of each wing, route airline to last row on wing & install in air bag, black airline = down pressure air bag, blue airline = up pressure air bag. Follow airline back to end row cutting a tee in each airline at each row. When return back to end row, cut airline to length & install into air bag. Install airline from each tee at each row & install in air bag for that row. If installing on a split row planter, keep trunk airline on front rank residue managers on each wing plumbed separate from back rank. When plumbing in WT (wheel track) rows, use center 4 or 6 rows that plant over the tractor & planter wheel tracks. If equipping on a narrow transport planter with 4 center rows & 6 rows are desired on the WT circuit, tie in the 1 row on each wing/side of the planter closest to the first & last center row. Install a tee in the center of each up pressure trunk airline. Use tees to route/install blue airline from the RU port on control box to each tee in center of each up pressure trunk airline. Install a tee into the down pressure trunk airline on the left wing & right wing. Route/install black airline from the RD port on control box to each tee in center of left & right wing down pressure trunk airline. Install tee in center of center section down pressure trunk airline. Route/install airline from WT port on control box to tee in the center of down pressure trunk airline on center of planter. If planter is dual rank, connect the trunk airline on the corn rows to the trunk airline of the bean rows. Use 2940-342 ball valves between corn row trunk airlines & bean row trunk airlines to be able to shut air supply off to bean rows when planting corn. [Refer to pages 32 – 47](#)

STEP 6: PERFORM A PRE-OPERATION TEST OF THE SYSTEM

Now that the system is installed, perform a pre-operation test. Start by folding/unfolding & lowering/raising the planter checking for slack in airline & in harnesses at hinge points. Check all electrical connections, cables, & airline making sure nothing was damaged. Next, with the tractor on, connect to the WiFi with your tablet or pull the Yetter screen up on the ISOBUS VT, & press the ACTIVE SYSTEM icon. The compressor will turn on, build to 145psi (100-120psi on the cab controller) & shut off. Check the interior of the control box housing (valve, fittings, & airline) for leaks. Apply 40psi to the RU port & watch your RMs as they should all raise to maximum up travel. Check for leaks on all up pressure circuits & fittings. When that leak check is finished, turn RU to 0psi & turn RD & WT to 40psi. Check all down pressure airline & fittings in these circuits for leaks & repair as needed. [Refer to pages 53 – 54](#)

****Installation Guide – Precision Planting Hydraulic Compressor**

STEP 1: RESIDUE MANAGER (RM) OR RM/COULTER COMBO INSTALLATION

Residue Manager Only: Install RM Assemblies securing with mounting hardware. Install the wheel mount assembly on the adjustment tube so the top hole of the wheel mount aligns to the 4th or 5th hole down from the top of the adjustment tube for conventional tillage/mellow soils, 5th or 6th hole from the top for no till/minimum till conditions. Install wheels on wheel mounts using hardware from the 2966-119 bolt bag. Install the RM wheels so that the left wheel leads, right wheel trails on the left side of planter; the right wheel leads, left wheel trails on right side of planter.

RM/Coulter Combo: Install the RM/Coulter Combo assembly using hardware from the 2940-128 bolt bag. Mount the coulter blade on the coulter arm hub & mount the RM wheels using the 5/8 Whiz Lock Nuts. RM wheels on combo units will install in the rear holes on both sides on all rows. It is recommended to set the coulter blade at seed depth or above. [Refer to diagram on pages 20 – 23](#)

STEP 2: TABLET/ISOBUS IN-CAB INSTALLATION

If using a tablet, mount Tablet & 2940-111 RAM Mount in tractor cab. Position Tablet within reach during operation without compromising safety/visibility from cab. The right rear corner post area is recommended so that the operator can see performance of residue managers while making adjustments. In both applications, install 2940-153A harness by feeding the bare ends thru the harness access hole into the cab. Bare ends get spliced to plug (not provided) that fits tractor's switched power source, splice red wire on 2940-153A to orange wire & splice black wires together on each harness. Leave the 2 pin connector at the tractor hitch. [Refer to diagram on page 24](#)

STEP 3: 2940-103A CONTROL BOX INSTALLATION

Mount control box in a safe location with mounts & hardware supplied. Mount the 2940-415 water separator/regulator assembly near control box. Locate Precision Planting hydraulic compressor, drain all tank pressure, & find the 3/8 tubing inside housing that routes between tank & the water separator. Cut & install a Tee into that airline. Measure & cut 2940-367 250psi rated airline & route from remaining port on Tee to inlet fitting (water trap side) of Yetter water separator/regulator assembly. Adjust regulator to only allow 100-120psi of clean, dry air beyond it. Measure & cut black airline from outlet fitting (regulator side) of water separator/regulator assembly to 3/8 inlet fitting on control box. Route provided 1/4" airline from the elbow on the bottom of the water separator/regulator assembly to the 1/4" PTC fitting on bottom of control box. Route 1/4" airline from 1/4" PTC fitting on the side of control box toward ground, as this airline will dispense moisture. [Refer to diagram on pages 25 & 32](#)

STEP 4: CONTROL BOX HARNESS INSTALLATION

Install 2940-166 VDM power cable with 40A breaker on tractor battery on the correct terminals, red = positive +, black = negative -. Connect VDM power extension (2940-167 or 2940-168) & route to tractor hitch. Install the AUX PWR Harness, 2940-164A or 2940-165A. The 2 pin connects to the 2940-153A from tractor cab, Anderson power connector connects to 8 gauge cable that routes to battery, & the black male 12 pin Deutsch connector connects to power harness connector on the side of the control box. If the 2940-103A control box is mounted at the back of the planter, 2940-170A (10ft), 2940-171A (30ft), & 2940-430A (20ft) AUX PWR extensions will be needed. [Refer to diagram on page 24](#)

ISOBUS HARNESS (IF APPLICABLE) Install the 2940-655 harness to 2940-654 on Yetter control box. Use 2940-657 (15ft) & 2940-658 (30ft) extensions to reach where the ISOBUS is being tied in. On JD planters, use the 2940-659 to plug in at the back of planter where terminating resistor harness was located. On RCM I Ag Leader systems, plug into the ISOBUS connections near the center of the planter at the Planter Control Module using the 2940-662 harness. On RCM II Ag Leader systems, route to tractor hitch & plug into back of tractor using 2940-656. [Refer to diagram on page 26](#)

STEP 5: PLUMBING AIRLINES

A group of airlines that route to residue manager air bags are referred to as trunk airlines. Airline routing from RU, RD, & WT to trunk airline is preferred to as a supply airline. Start by routing trunk airlines: route black (down pressure) & blue (up pressure) airline on each wing/side of planter. Start at end row of each wing, route airline to last row on wing & install in air bag, black airline = down pressure air bag, blue airline = up pressure air bag. Follow airline back to end row cutting a tee in each airline at each row. When return back to end row, cut airline to length & install into air bag. Install airline from each tee at each row & install in air bag for that row. If installing on a split row planter, keep trunk airline on front rank residue managers on each wing plumbed separate from back rank. When plumbing in WT (wheel track) rows, use center 4 or 6 rows that plant over the tractor & planter wheel tracks. If equipping on a narrow transport planter with 4 center rows & 6 rows are desired on the WT circuit, tie in the 1 row on each wing/side of the planter closest to the first & last center row. Install a tee in the center of each up pressure trunk airline. Use tees to route/install blue airline from the RU port on control box to each tee in center of each up pressure trunk airline. Install a tee into the down pressure trunk airline on the left wing & right wing. Route/install black airline from the RD port on control box to each tee in center of left & right wing down pressure trunk airline. Install tee in center of center section down pressure trunk airline. Route/install airline from WT port on control box to tee in the center of down pressure trunk airline on center of planter. If planter is dual rank, connect the trunk airline on the corn rows to the trunk airline of the bean rows. Use 2940-342 ball valves between corn row trunk airlines & bean row trunk airlines to be able to shut air supply off to bean rows when planting corn. [Refer to pages 32 – 47](#)

STEP 6: PERFORM A PRE-OPERATION TEST OF THE SYSTEM

Now that the system is installed, perform a pre-operation test. Start by folding/unfolding & lowering/raising the planter checking for slack in airline & in harnesses at hinge points. Check all electrical connections, cables, & airline making sure nothing was damaged. Next, with the tractor on, connect to the WiFi with your tablet or pull the Yetter screen up on the ISOBUS VT, & press the ACTIVE SYSTEM icon. The compressor will turn on, build to 145psi (100-120psi on the cab controller) & shut off. Check the interior of the control box housing (valve, fittings, & airline) for leaks. Apply 40psi to the RU port & watch your RMs as they should all raise to maximum up travel. Check for leaks on all up pressure circuits & fittings. When that leak check is finished, turn RU to 0psi & turn RD & WT to 40psi. Check all down pressure airline & fittings in these circuits for leaks & repair as needed. [Refer to pages 53 – 54](#)

*****Installation Guide – Case IH Series Hydraulic Compressor**

STEP 1: RESIDUE MANAGER (RM) OR RM/COULTER COMBO INSTALLATION

Residue Manager Only: Install RM Assemblies securing with mounting hardware. Install the wheel mount assembly on the adjustment tube so the top hole of the wheel mount aligns to the 4th or 5th hole down from the top of the adjustment tube for conventional tillage/mellow soils, 5th or 6th hole from the top for no till/minimum till conditions. Install wheels on wheel mounts using hardware from the 2966-119 bolt bag. Install the RM wheels so that the left wheel leads, right wheel trails on the left side of planter; the right wheel leads, left wheel trails on right side of planter.

RM/Coulter Combo: Install the RM/Coulter Combo assembly using hardware from the 2940-128 bolt bag. Mount the coulter blade on the coulter arm hub & mount the RM wheels using the 5/8 Whiz Lock Nuts. RM wheels on combo units will install in the rear holes on both sides on all rows. It is recommended to set the coulter blade at seed depth or above. [Refer to diagram on pages 20 – 23](#)

STEP 2: TABLET/ISOBUS IN-CAB INSTALLATION

If using a tablet, mount Tablet & 2940-111 RAM Mount in tractor cab. Position Tablet within reach during operation without compromising safety/visibility from cab. The right rear corner post area is recommended so that the operator can see performance of residue managers while making adjustments. In both applications, install 2940-153A harness by feeding the bare ends thru the harness access hole into the cab. Bare ends get spliced to plug (not provided) that fits tractor's switched power source, splice red wire on 2940-153A to orange wire & splice black wires together on each harness. Leave the 2 pin connector at the tractor hitch. [Refer to diagram on page 24](#)

STEP 3: 2940-103A CONTROL BOX INSTALLATION

Mount control box in a safe location with mounts & hardware supplied. Mount the 2940-415 water separator/regulator assembly near control box. Locate hydraulic compressor & drain all tank pressure. Plumbing in to the compressor can happen by A) installing a 2940-408 3/8PTC elbow fitting in the bung on the side of tank, or B) find the 3/8 tubing that routes between the top of tank & valve manifold. Cut & install a Tee into that airline. Measure & cut 2940-367 250psi rated airline & route from remaining port on the Tee to inlet fitting (water trap side) of Yetter water separator/regulator assembly. Adjust regulator to only allow 100-120psi of clean, dry air beyond it. Measure & cut 2940-345 black airline from outlet fitting (regulator side) of water separator/regulator assembly to inlet fitting of control box. Route provided 1/4" airline from the elbow on the bottom of the water separator/regulator assembly to the 1/4"PTC fitting on the bottom of control box. Route 1/4" airline from remaining 1/4"PTC fitting on control box toward the ground, as this airline will dispense moisture. [Refer to diagram on pages 25 & 32](#)

STEP 4: CONTROL BOX HARNESS INSTALLATION

Install 2940-166 VDM power cable with 40A breaker on tractor battery on the correct terminals, red = positive +, black = negative -. Connect VDM power extension (2940-167 or 2940-168) & route to tractor hitch. Install the AUX PWR Harness, 2940-164A or 2940-165A. The 2 pin connects to the 2940-153A from tractor cab, Anderson power connector connects to 8 gauge cable that routes to battery, & the black male 12 pin Deutsch connector connects to power harness connector on the side of the control box. If the 2940-103A control box is mounted at the back of the planter, 2940-170A (10ft), 2940-171A (30ft), & 2940-430A (20ft) AUX PWR extensions will be needed. [Refer to diagram on page 24](#)

ISOBUS HARNESS (IF APPLICABLE) Install the 2940-655 harness to 2940-654 on Yetter control box. Use 2940-657 (15ft) & 2940-658 (30ft) extensions to reach where the ISOBUS is being tied in. On JD planters, use the 2940-659 to plug in at the back of planter where terminating resistor harness was located. On RCM I Ag Leader systems, plug into the ISOBUS connections near the center of the planter at the Planter Control Module using the 2940-662 harness. On RCM II Ag Leader systems, route to tractor hitch & plug into back of tractor using 2940-656. [Refer to diagram on page 26](#)

STEP 5: PLUMBING AIRLINES

A group of airlines that route to residue manager air bags are referred to as trunk airlines. Airline routing from RU, RD, & WT to trunk airline is referred to as a supply airline. Start by routing trunk airlines: route black (down pressure) & blue (up pressure) airline on each wing/side of planter. Start at end row of each wing, route airline to last row on wing & install in air bag, black airline = down pressure air bag, blue airline = up pressure air bag. Follow airline back to end row cutting a tee in each airline at each row. When return back to end row, cut airline to length & install into air bag. Install airline from each tee at each row & install in air bag for that row. If installing on a split row planter, keep trunk airline on front rank residue managers on each wing plumbed separate from back rank. When plumbing in WT (wheel track) rows, use center 4 or 6 rows that plant over the tractor & planter wheel tracks. If equipping on a narrow transport planter with 4 center rows & 6 rows are desired on the WT circuit, tie in the 1 row on each wing/side of the planter closest to the first & last center row. Install a tee in the center of each up pressure trunk airline. Use tees to route/install blue airline from the RU port on control box to each tee in center of each up pressure trunk airline. Install a tee into the down pressure trunk airline on the left wing & right wing. Route/install black airline from the RD port on control box to each tee in center of left & right wing down pressure trunk airline. Install tee in center of center section down pressure trunk airline. Route/install airline from WT port on control box to tee in the center of down pressure trunk airline on center of planter. If planter is dual rank, connect the trunk airline on the corn rows to the trunk airline of the bean rows. Use 2940-342 ball valves between corn row trunk airlines & bean row trunk airlines to be able to shut air supply off to bean rows when planting corn. [Refer to pages 32 – 47](#)

STEP 6: PERFORM A PRE-OPERATION TEST OF THE SYSTEM

Now that the system is installed, perform a pre-operation test. Start by folding/unfolding & lowering/raising the planter checking for slack in airline & in harnesses at hinge points. Check all electrical connections, cables, & airline making sure nothing was damaged. Next, with the tractor on, connect to the WiFi with your tablet or pull the Yetter screen up on the ISOBUS VT, & press the ACTIVE SYSTEM icon. The compressor will turn on, build to 145psi (100-120psi on the cab controller) & shut off. Check the interior of the control box housing (valve, fittings, & airline) for leaks. Apply 40psi to the RU port & watch your RMs as they should all raise to maximum up travel. Check for leaks on all up pressure circuits & fittings. When that leak check is finished, turn RU to 0psi & turn RD & WT to 40psi. Check all down pressure airline & fittings in these circuits for leaks & repair as needed. [Refer to pages 53 – 54](#)

Residue Manager (RM) Installation



ENGAGE THE CYLINDER STOPS ON THE PLANTER LIFT WHEELS TO "LOCK" THE PLANTER IN THE UP POSITION

Installation overview:

- Prior to installation of each RM mounting bracket assembly, check the freedom of motion of the parallel linkage or pivot arm.
- The installation process should be done with the planter raised, half folded for transport, & the row units fully extended down.
- Install the 2940 RM or RM/Coulter Combo mounting bracket assembly centered & level side to side on each planter row unit.
- If planter manufacturer is John Deere & equipped with HD scrapers on the True V opener blades, a 2940-049A kit will need installed to space the RM or RM/Coulter Combo mounting bracket assembly out to avoid interference. **(See page 57)**
- To manually lock up RM, push RM all the way up & slide pin thru upper most hole on tube & ½ hole on upper linkage
- To manually lock up RM/Coulter Combo, loosen jam nut on down stop bolt on backside of faceplate, adjust bolt inward until pivot arm is all the way up, & then tighten jam nut

For Harvest International, Horsch, John Deere, Kinze, & White Models Installing RM Only

Step 1: Place 1) Pneumatic RM Assembly (2940-190A OR 2940-192A), 1) Mounting Hardware Bolt Bag (2940-142), 1) Wheel Mount Weld Assembly (2940-215/2940-216), 1) RH Wheel Assembly (2966-140), 1) LH Wheel Assembly (2966-141), & 1) Wheel Mount Bolt Bag (2966-119), & 2) Bearing Shields (2967-392) at each planter row unit. Install Pneumatic RM assembly using 3) ½" X 1-1/2" GR5 bolts, 6) ½" flat washers, & 3) ½" lock nuts. Use the diagram below for hole alignment, as well as direction of mounting bolts. Tighten the hardware. **Tools needed are ¾ socket, ¾ wrench, impact wrench, & 10" extension.**

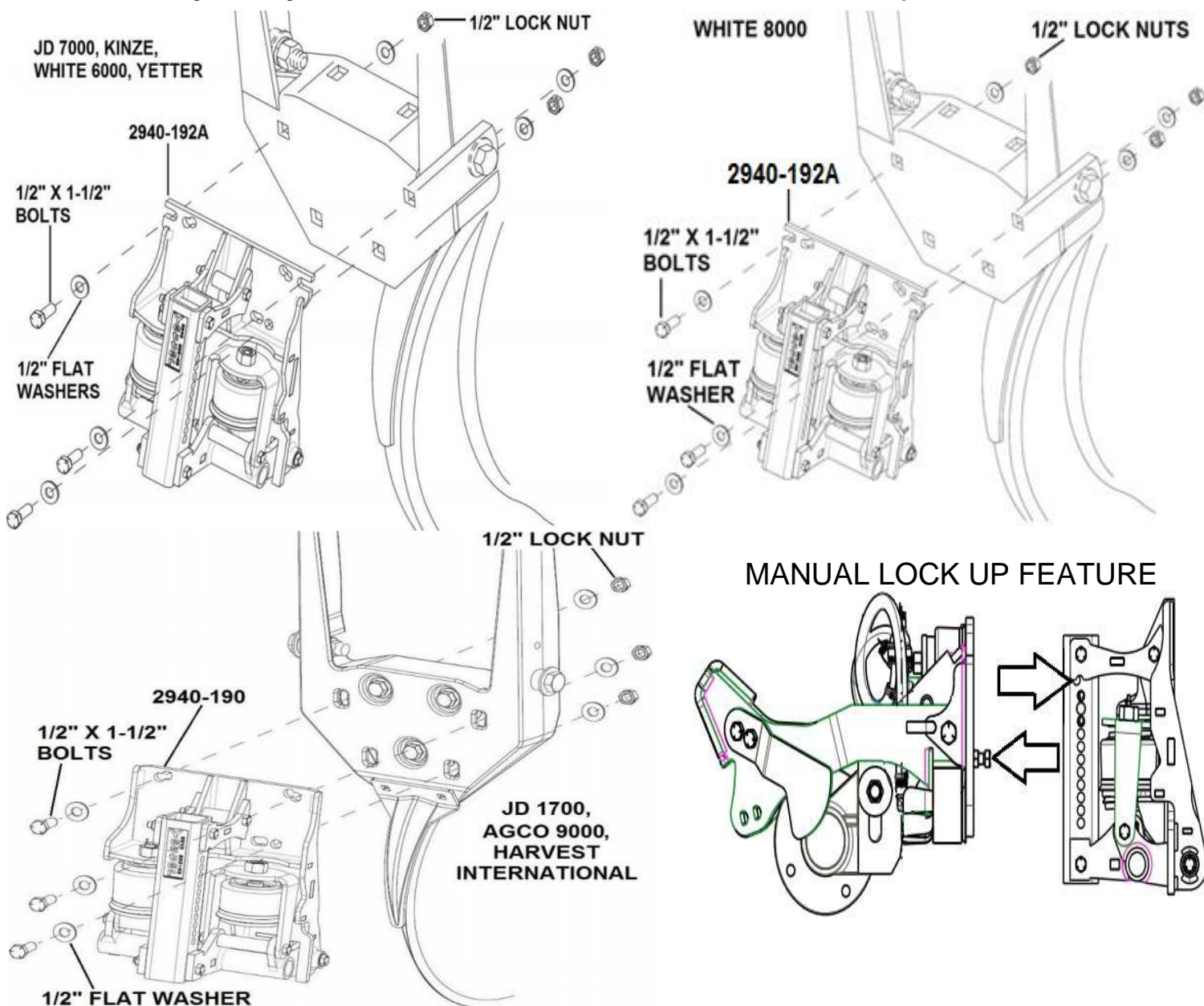

NOTE: AGCO 9000 units will use ½" x 2" mounting bolts!

Residue Manager(RM) Installation Con't

For Case Models Installing RM Only

Step 1: 800 – 1200 SERIES: Place 1) Pneumatic RM Assembly (2940-190A), 1) CNH Adaptor Bracket (2940-209), 1) CNH Mounting Bolt Bag (2940-145), 1) Wheel Mount (2940-215/2940-216), 1) Cyclo Stop Casting Bolt Bag (2965-135), 1) RH Wheel Assembly (2966-140), 1) LH Wheel Assembly (2966-141), & 1) Wheel Mount Bolt Bag (2966-119), & 2) Bearing Shields (2967-392) at each row unit. Mount 2940-190A to the 2940-209 using 3) 1/2" X 1-1/2" GR5 bolts (note bolt direction), 3) 1/2" flat washers, & 3) 1/2" lock nuts. Mount this assembly to row unit attachment casting using 2) 1/2" X 3-1/2" bolts & 2) 1/2" lock nuts. Install the 2) Cyclo Stop casting pieces to each upper parallel arm using either A) 3/8 X 1-1/4 bolts, 3/8 washer (not shown), & 3/8 lock nuts or B) 1/2" X 1-1/4" bolts & 1/2" lock nuts. Note direction of mounting bolt. Cyclo stop castings can also be mounted to square hole on the upstop flange under top parallel arms.

2100 SERIES: Place 1) Pneumatic RM Assembly (2940-190A), 1) Mounting Hardware Bolt Bag (2940-142), 1) Wheel Mount Weld Assembly (2940-215/2940-216), 1) RH Wheel Assembly (2966-140), 1) LH Wheel Assembly (2966-141), & 1) Wheel Mount Bolt Bag (2966-119), & 2) Bearing Shields (2967-392) at each planter row unit. Use the same bolt direction as below. The top 2 mounting bolts will be the same as diagram below. Use the bottom hole that is aligned with the OEM CNH faceplate adaptor. The cyclo stop casting kit will not be needed for these row units. Cyclo Stop Casting not needed for this model of row unit!

Tools needed are 3/4 socket, 9/16 socket, 3/4 wrench, 9/16 wrench, impact wrench, & 10" extension.

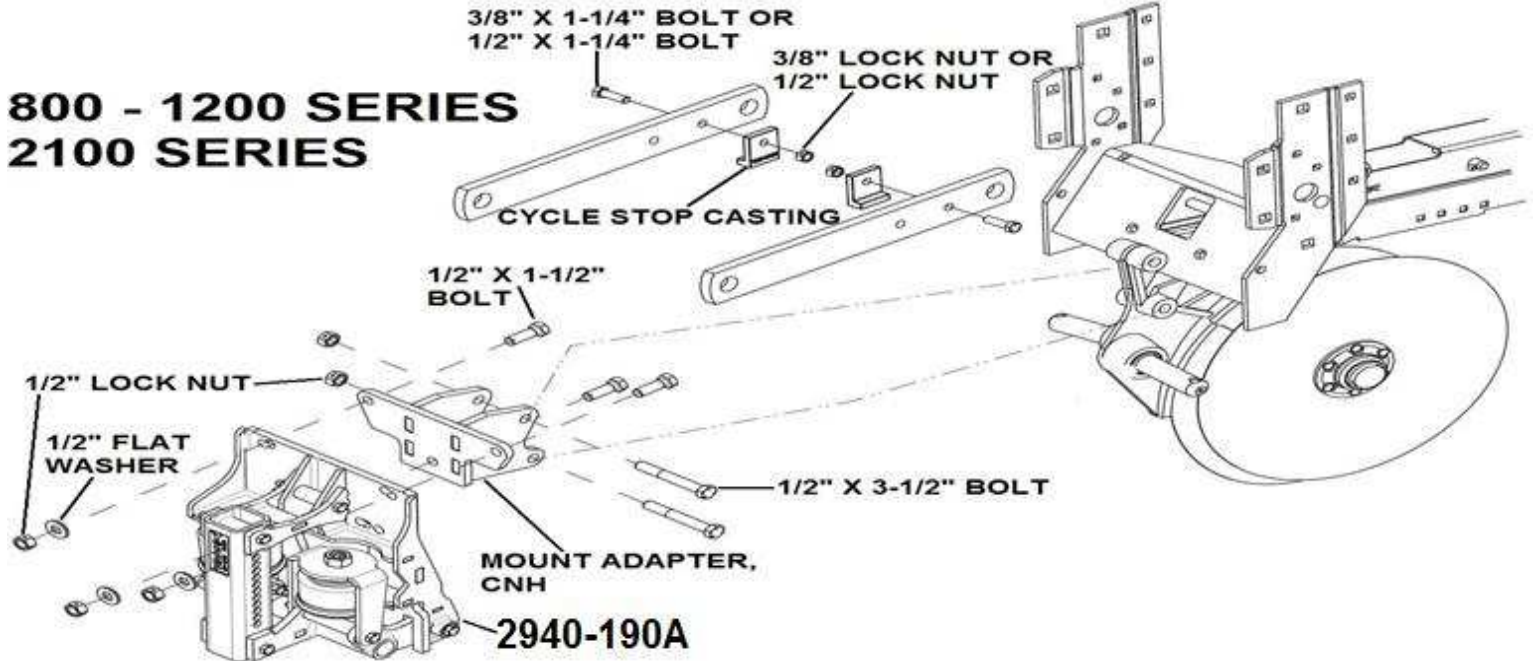

Step 2: Install 1) 2940-380 3/8" PTC X 1/8" BSPP male fitting to each air bag using an 11/16 wrench. Do not over tighten.

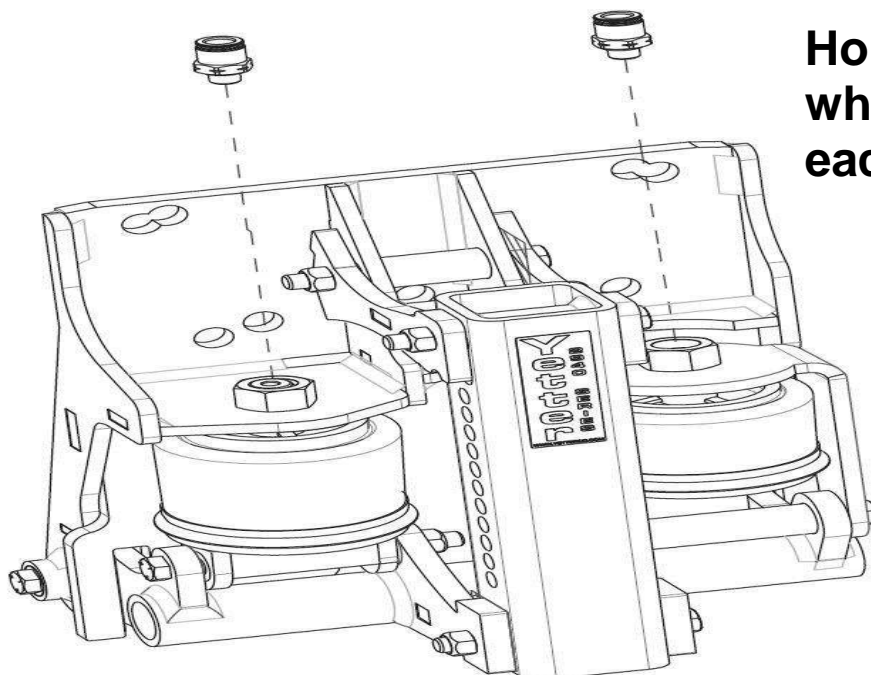

Residue Manager Installation Con't

Step 3: Install the Wheel Mount (2940-215 or 2940-216) on the adjustment tube of the mounting bracket assembly. Recommended mounting location is **5th hole** down from the top of the adjustment tube mounts to the top hole of the wheel mount. Adjustments may need to be made depending on tillage practice, soil conditions, and/or residue thickness.

Optional 2940-093 Snakehead Extension Kit: Install 2) ext. brackets using 2) 3/8 X 3 bolts & 2) 3/8 lock nuts. Install snakehead to brackets using 4) 3/8 X 1 bolts & 4) 3/8 lock nuts.

Tools needed are a 9/16 socket, 9/16 wrench, impact, and a 10" extension.

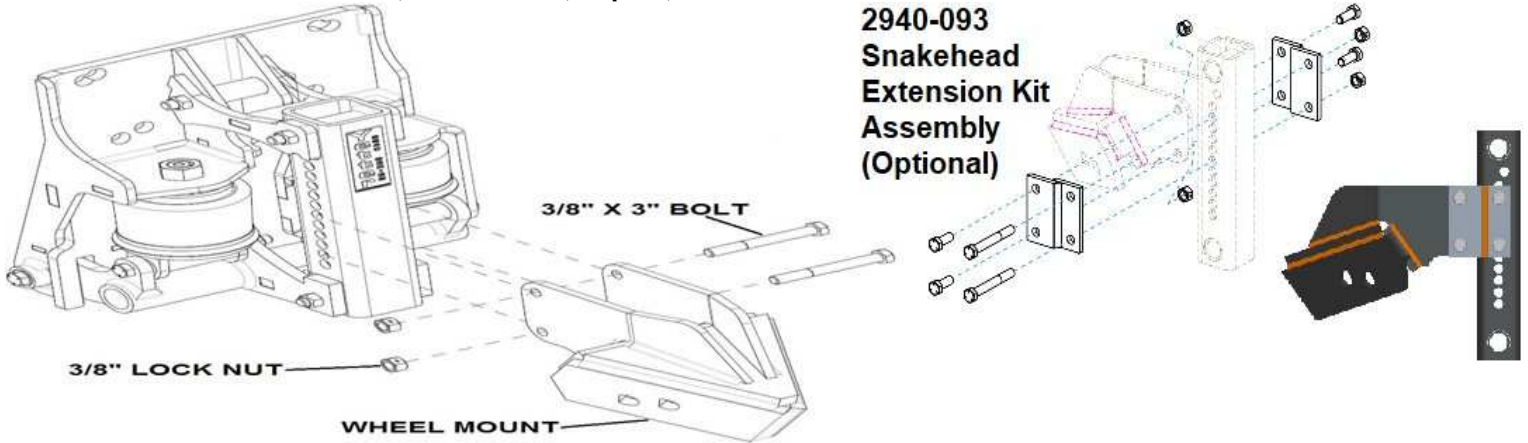

Step 4: Mount the RM wheels on the wheel mount using 2) 5/8" lock washers & 2) 5/8 hex nut. Mount the wheels so the left side of the planter has the left wheel leading, right wheel trailing. Mount the wheels so that right side of the planter has the right wheel leading, left wheel trailing. Right & left is determined by standing behind the planter looking at the tractor or sitting in the tractor facing forward. Diagram below is proper installation for the right side of the planter. **Tighten using a 15/16 wrench. (Ratcheting wrench if available)** **Note: Properly install row cleaner wheels so that wheel teeth curve back when entering field debris.**

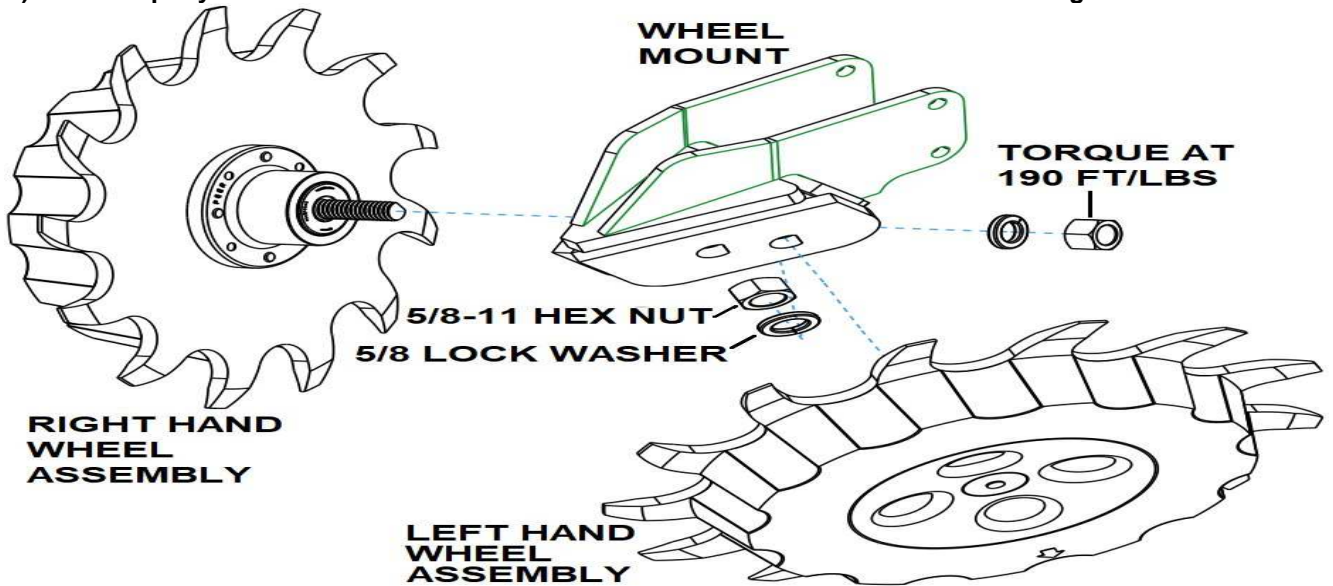

BEVEL WILL BE ON OUTSIDE OF BLADE

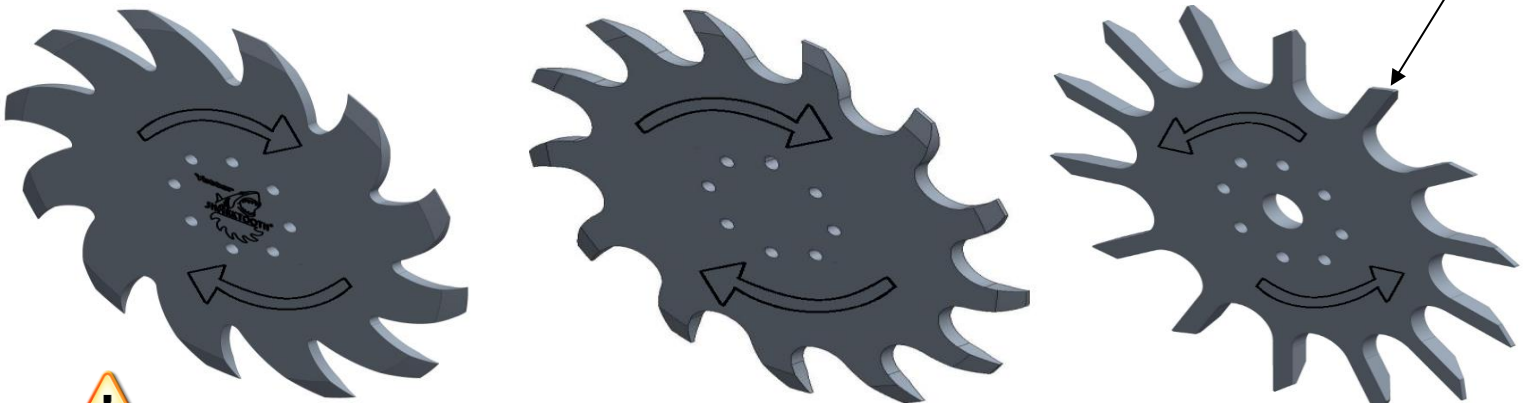

It is highly recommended to wear gloves & use caution when tightening wheels!

RM/Coulter Combo Installation

Step 1: Place 1) RM/ Coulter Combo assembly (2940-126A or 2940-130A), 1) Coulter Blade, 1) Mounting Bolt Bag (2940-128), 1) RH wheel assembly (2966-116), & 1) LH wheel assembly (2966-117) at each row unit. Mount the RM/Coulter Combo assembly to the row unit face plate using 3) 1/2" X 1 1/2" bolts and 3) 1/2" lock nuts. See the diagrams below for bolt alignment and bolt direction. Tighten hardware. **Tools needed are 3/4" socket, 3/4" wrench, impact, & 10" extension.**

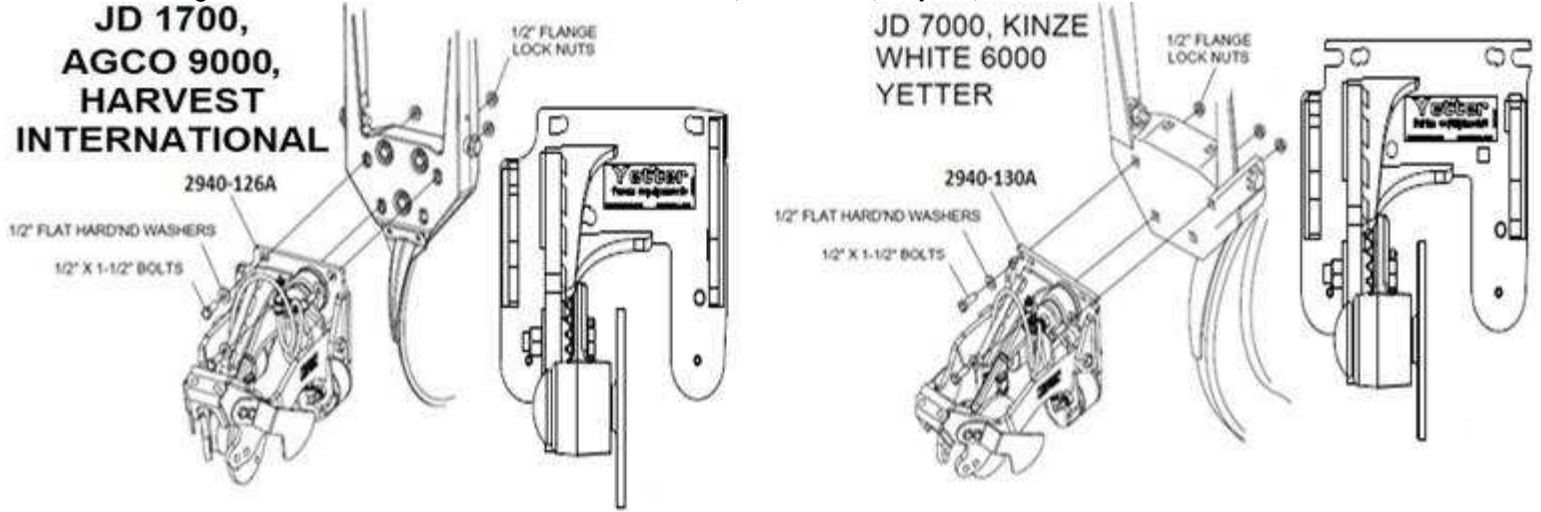

Step 2: Install coulter blade using 4) 1/2" X 1 1/4" bolts & 4) 1/2" lock nuts using a 3/4" socket, 3/4" wrench, impact, & 10" extension.

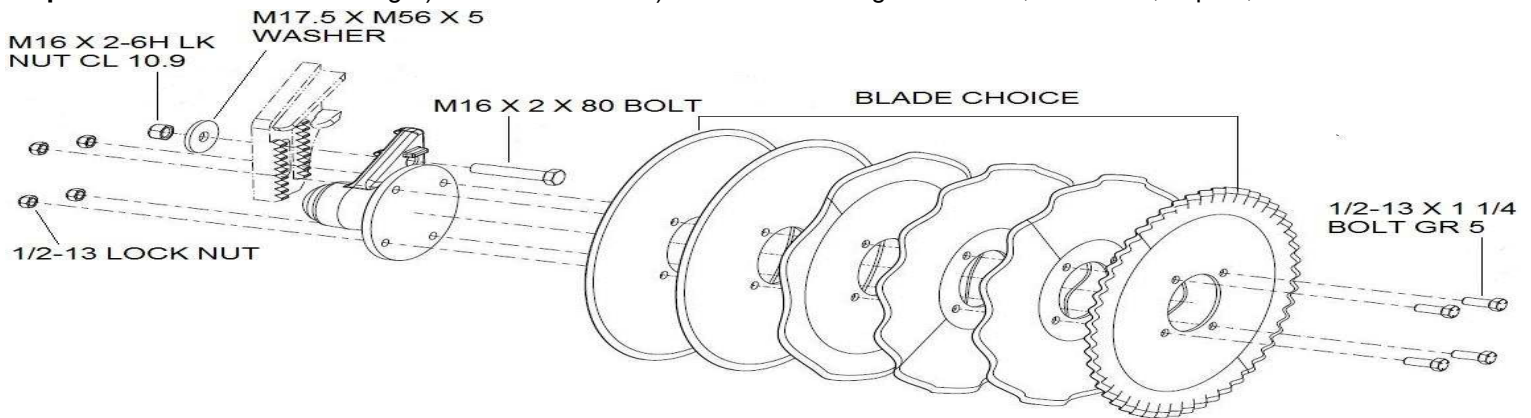

NOTE: Adjust coulter blade depth equal to or above planter DD opener blades. Adjust blade depth as blade wears. Planter DD blades that are worn to 14 1/4" or smaller in diameter should be replaced. Example: 14 1/4" blades will have 3/8" shallower planting depth than 15" blades at same gauge wheel adjustment setting.

STEP 3: Install each of the RM wheels in the rear D-bolt holes using a 5/8 serrated flange nuts & tighten using a 15/16" wrench. If assembling the drop down kit, assemble the RH & LH drop down parts using 1) flat top D-bolt & 1) 5/8 whiz lock per side.

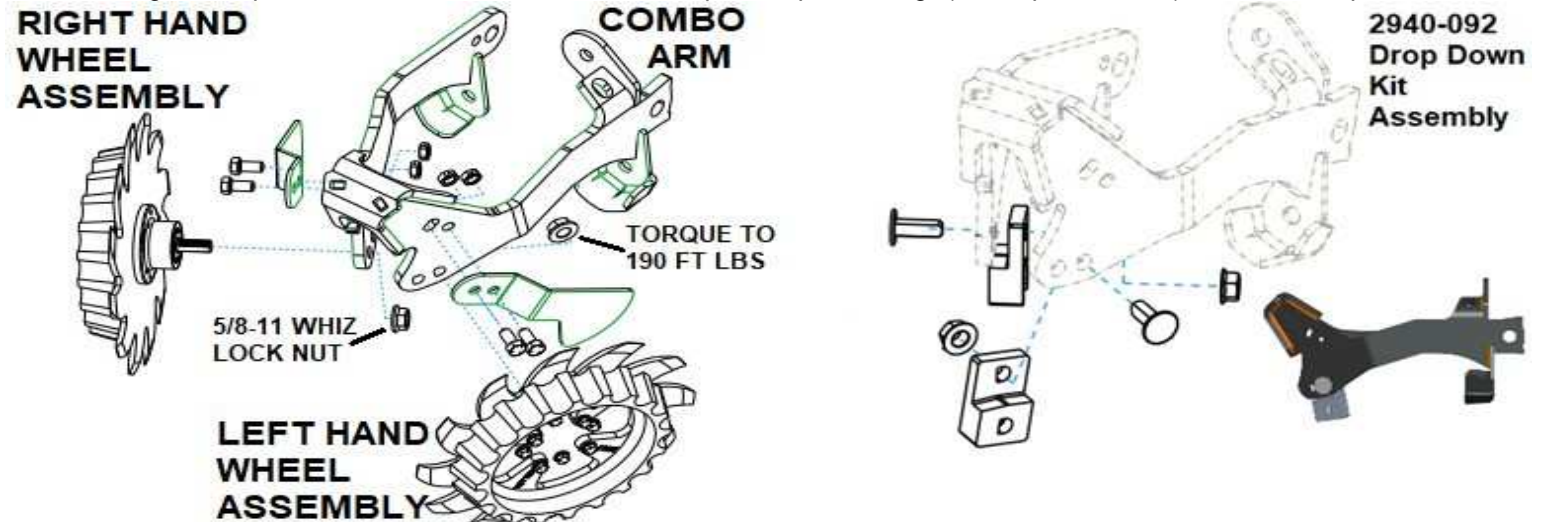

It is highly recommended to wear gloves & use caution when tightening wheels!

Tablet, Switched Power, & Main Power Installation

Skip steps 1 & 2 if using ISOBUS monitor

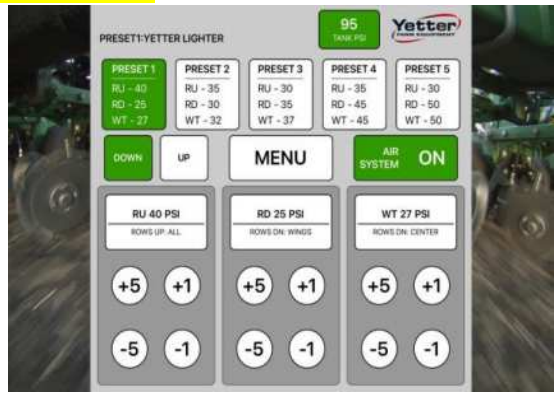
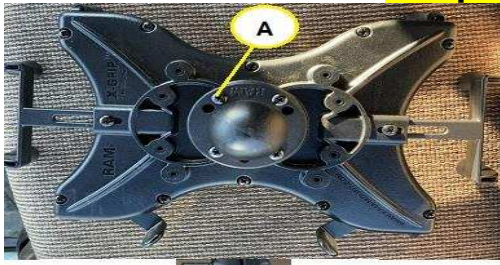

Step 1: Begin installing the 2940-111 once an adequate mounting location has been found. Fix the base component of the 2940-111 Mounting Bracket in place to the back of the Tablet Holder using 4 – screws (A). Use items labeled B if mounting to a slotted, flat mounting system & securely tighten the hardware. Use items C if using a tubular mounting system

Step 2: Attach the Double Socket Arm to Tablet Holder & Ball Base, tighten clamp by turning the handle clockwise.

Step 3: Locate the 2940-153A cable & route bare ends into tractor cab, connector end should be at the tractor hitch. Install the wire harness (not provided) for your tractor at the bare end of the 2940-153A & connect to tractors switched power source. Secure the black ground wires together & the red wire on the 2940-153A to the orange wire on the OEM harness. **Cigarette outlet is NOT a switched port on all models of tractors, and therefore should not be used.**



Switched Power Source Connector part #'s:

JOHN DEERE PART #: RE67013

CNH PART #: 187103A1

CAT P/N: AG233356

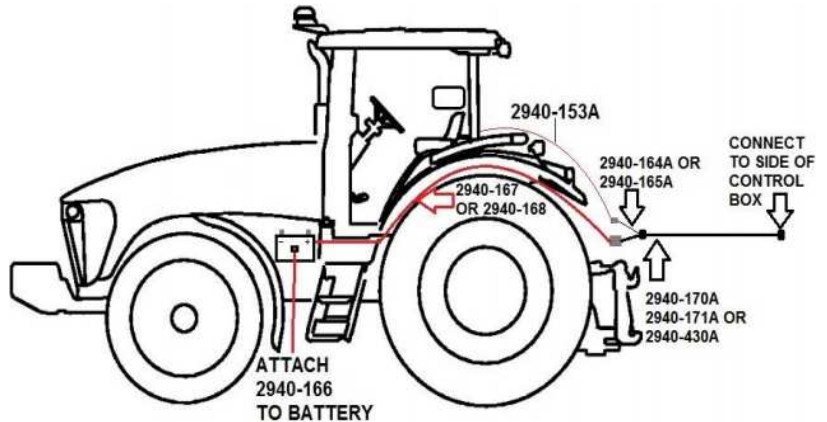
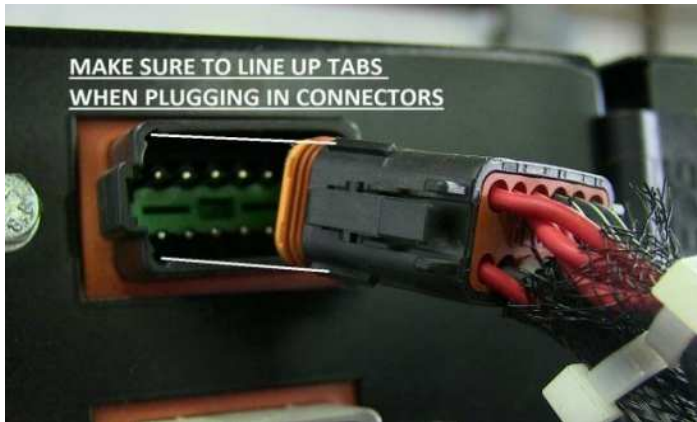

FAILURE TO LINE UP TABS WHEN PLUGGING MALE INTO FEMALE CONNECTORS CAN RESULT IN SHORT CIRCUIT. ALSO CHECK TAB & SLOT SIZES, PLUGGING CONNECTORS IN BACKWARDS WILL RESULT IN A FAULTY SYSTEM!!!

Step 4: Install 2940-166 VDM power cable/40A breaker on battery, red cable to positive (+) stud, black cable to negative (-) stud.

Step 5: Install the 2940-167 (10ft) or 2940-168 (20ft) VDM power extension cable to the 2940-166 & route to the hitch of the tractor.

Step 6: Install the 2940-164A (5ft) or 2940-165A (10ft) PWR to Air Harness. This harness has 3 ends. Install the Anderson power connector to power extension to battery from step 5, install 2 pin Duetsch to 2940-153A switched power harness from Step 3, & install the male black 12 pin Deutsch connector to female end on the side of control box. If the control box is mounted further back than the hitch of the planter, PWR to Air Extension harnesses need to be installed. Use 2940-170A (10ft), 2940-171A (30ft), & 2940-430A (20ft) Extensions to reach to control box. On planters that fold, install PWR to Air extensions through draft tube or zip tie to outside frame. If routing into the draft tube, **DO NOT** have a splice inside the draft.

Step 7: Zip tie the cables and harnesses as needed keeping the install as neat as possible & harnesses out of harm's way.

2940-103A Control Box Installation

2940-103A Control Box is an assembled unit that utilizes compressed air supplied by the OEM hydraulic compressor to operate the 2940 Air Adjust System. In some situations, a mount may need to be built to install the 2940-103A in an adequate location.

OEM ELECTRIC COMPRESSORS ALREADY ONBOARD PLANTERS WILL NOT OPERATE YETTER 2940 AIR ADJUST SYSTEMS!

NOTE: THE IMAGES BELOW CONTAIN THE 2940-103 CONTROL BOX MANUFACTURED FROM 2013 -2020.

2940-082 (See page 71 for diagram)



2940-083 (See page 72 for diagram)



2940-084 (handrail by compressor)



2940-084 (handrail between bulk fill tanks)



(See page 72 for diagram of the 2940-084)

! Once the 2940-103A Control Box is mounted, install the Aux Extension (black 12 pin Deutsch) that routes from the tractor hitch into the side of the Control Box from [page 24](#).

Water Separator/Regulator Installation

Install the 2940-415 water separator/regulator assembly near the control box in a suitable location out of harm's way. The water separator removes moisture from entering the system's control box. Install the assembly with the water trap vertical & elbow fitting towards the ground. Adjust the regulator (2940-404) to only allow 100 – 120psi into the control box. Below are some examples of mounting locations for the water separator/regulator assembly.



ISOBUS Installation – To Tractor Hitch Connector

- Step 1:** Install 2940-655 Yetter ISOBUS Y Harness at Yetter Control Box. Install triangular 3 pin connector on the 2940-655 to triangular 3 pin connector on the 2940-654 Yetter Control Harness.
- Step 2:** Install 2940-657 (15ft) or 2940-658 (30ft) extension harnesses to 2940-655 & route to ISOBUS connector on hitch of the tractor.
- Step 3:** Install 2940-656 ISOBUS Hitch Harness to 2940-657 or 2940-658 at tractor hitch. Plug other end of 2940-656 into tractors ISOBUS port on hitch.

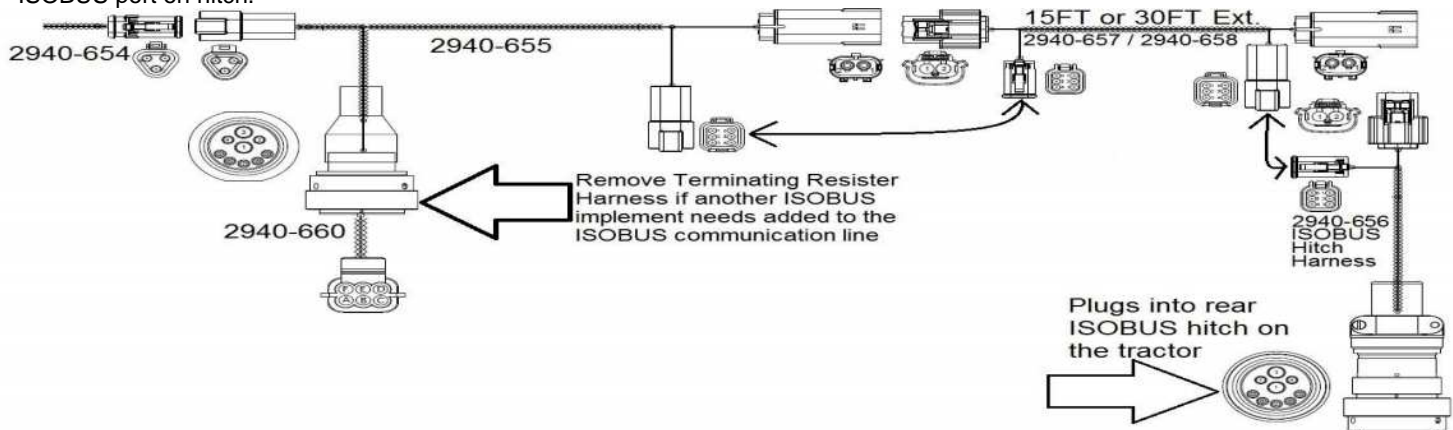

ISOBUS Installation – John Deere

- Step 1:** Install the 2940-655 Yetter ISOBUS Y Harness at the Yetter Control Box. Install the triangular 3 pin connector on the 2940-655 to the triangular 3 pin connector on the 2940-654 Yetter Control Harness.
- Step 2:** Remove the JD rear terminating resistor harness from the planter. Install the 2940-659 JD ISOBUS Adapter Harness.
- Step 3:** Install the 2940-657 (15ft) or 2940-658 (30ft) extension harnesses between the 2940-655 & 2940-659.

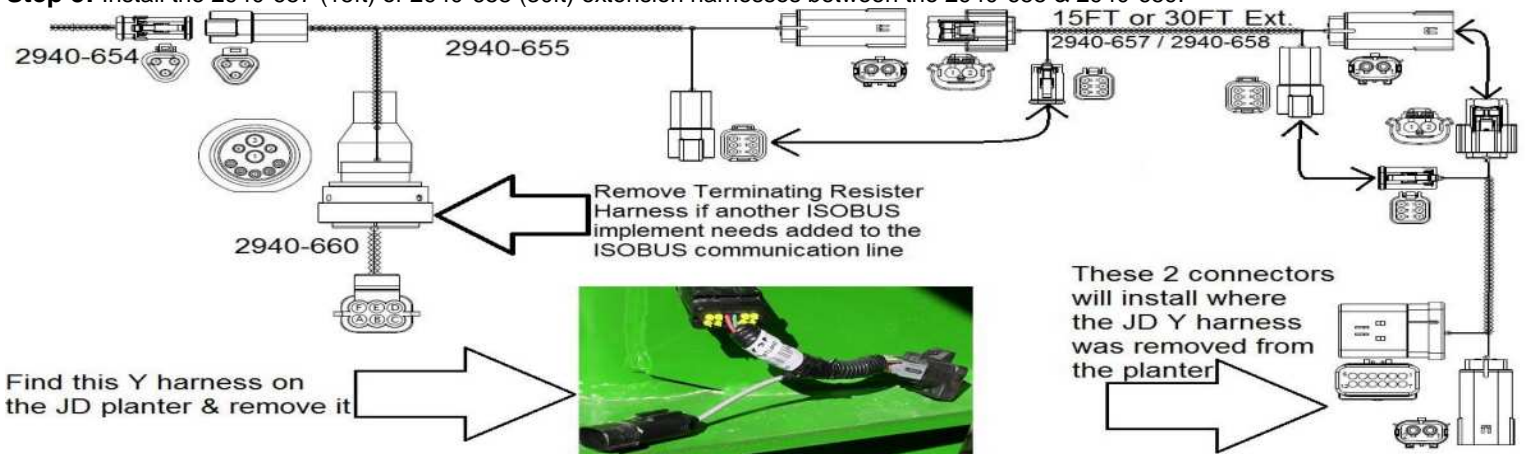

ISOBUS Installation – Ag Leader (RCM I)

- Step 1:** Remove terminating resistor at Planter Control Module of Ag Leader system, install 2940-662 Ag Leader Adaptor harness in its place.
- Step 2:** Install 2940-658 (30ft) extension harnesses between the 2940-662 & 2940-658. (2 pin connector not used, apply tape to seal off)
- Step 3:** Install 2940-661 at the Yetter Control Box. Install 3 pin triangular connectors together, 6 pin Deutsch connectors install together, & the terminating resistor removed in (Step 1) installs to remaining open connector.

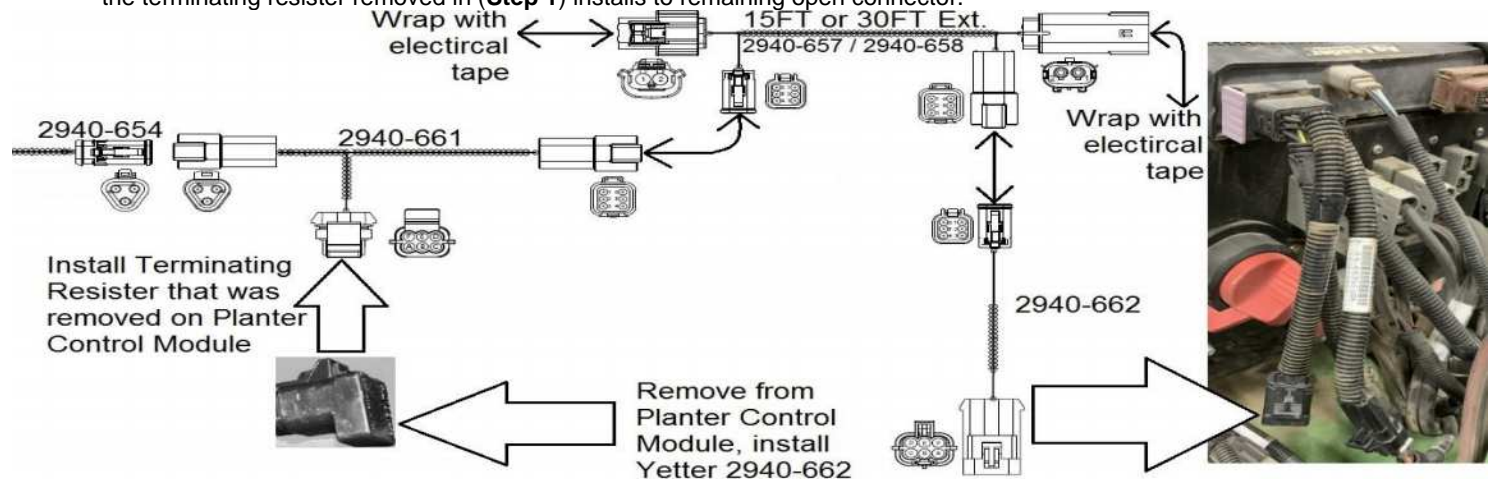

Yetter Compressor Installation

Step 1: Preparation

ELECTRIC COMPRESSOR: The crate labeled 2940-050A includes 1) Yetter electric compressor, 1) 2940-181 Y harness, 1) 2940-189 10FT Compressor Control Harness, 1) 2940-150 80A Breaker Cable, 1) 2940-151 Main Power Extension, & 2) 2940-163 20FT Main Power Extensions. Open filter assembly, inspect condition of filter, reinstall. (SEE PAGE 12 FOR FILTER LOCATION)

HYDRAULIC COMPRESSOR: The crate labeled 2940-055 includes the Yetter hydraulic compressor, 1 liter bottle of oil, 2940-181 Y harness, & 2940-189 10FT compressor control harness. Remove compressor from crate. Remove the housing by removing 6 bolts (4 are pictured in picture 1 below, the other 2 are on the opposite side of the housing) using a ratchet with 7/16 socket & 7/16 wrench. Remove the dipstick & slowly fill pump with provided oil until oil reaches fill line on the sight glass. Fill the pump slowly as there is a delay between oil entering pump & seeing oil on the sight glass. Confirm oil level is full on the dipstick as well. Reinstall dipstick, housing, & control block. Remove wing nut on the air filter housing, remove air filter cover, & inspect condition of the air filter. Reinstall filter, cover, & wing nut making sure filter is sealed between filter base plate & cover.

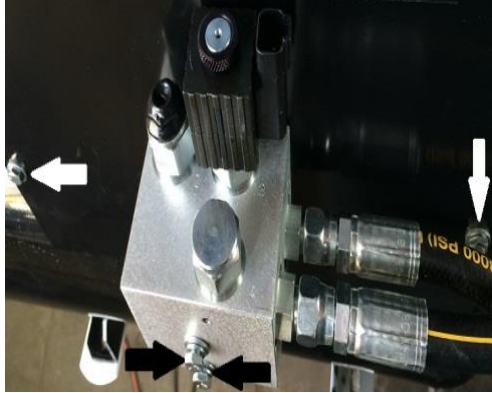

Step 2: Mounting

Every planter/tractor combination will contain its own unique situations in regard to mounting the 2940 Compressor Assembly for clearance/accessibility. **YOU SHOULD EXERCISE YOUR OWN BEST JUDGEMENT TO FIT YOUR SITUATION.** Begin by locating a suitable mounting location. Placement will vary on make & model of planter. Use mounts supplied or **depending on application different mounts may need to be built.** See examples below labeled customer built bracket. Be sure to check clearance in all locations, especially noting tractor tires, folding/unfolding the planter for transport mode, marker arms, fertilizer tanks, & 2-point top link. Yetter has 4 different mounting kits; 2940-085 to mount compressor to top link of the 2 point hitch, 2940-086 to mount to draft tube, 2940-090 to mount to an 8" X 12" bar, & 2940-091 to mount to an 8" X 16" bar. See pages 72 – 73 in the Part Identification for proper assembly of the mounting kit & compressor mounting. A process of folding & unfolding, turning in a tight circle, & raising/lowering markers & planter is recommended to ensure compressor clearance.

2940-085 – 2 Point Mount



2940-086



2940-090



2940-091



CUSTOMER BUILT BRACKETS (Call Yetter Service Department for additional photos)



Yetter Electric Compressor Installation

Step 3: On electric compressor installation, install the 2940-150 on the tractor battery. Red cable connects to positive battery post & black cable connects to negative battery post. Install the 2940-151 (10ft) & 2940-163 (20ft) main power extensions until you reach the compressor. Install the connector on extension to the large connector on electric compressor unit.



Hydraulic Hose and Fitting Kits

- All fittings & adaptors do not have to be used
- Additional fittings & adaptors may need purchased

2940-088 (PLANTER)	2940-089 kit (STAND ALONE)	Part #	Part Name	Description
Qty in kit	Qty in kit			
4	2	2515-324	ELBOW	90 DEG, 3/4 SAE TO -6 JIC
	2	2515-327	ADAPTER	3/4-16 SAE TO -6 JIC
3		2515-329	ADAPTER	REDUCER, -8 F TO -6 M JIC
2	2	2515-411	ELBOW	90 DEG 3/4 SAE TO -8JIC
3	1	2515-425	TEE	TEE 3/4 SAE
2		2515-428	ELBOW	JIC-6 90 DEGREE SWIVEL
3		2515-430	TEE	JIC-8 RUN TEE
2	2	2515-431	ADAPTER	9/16 SAE TO -6 JIC ADAPTER
1		2515-432	ELBOW	JIC-8 90 DEGREE SWIVEL
2	2	2515-831	HOSE	3/8 10FT HOSE -6 JIC F
1	1	2515-832	HOSE	1/2 10FT HOSE -8 JIC F
1	1	2515-833	ADAPTER	3/4 SAE TO -8 JIC
	2	2515-834	COUPLER	PIONEER, POPPET STYLE
1	1	2515-848	ELBOW	90 DEG, 1/4 SAE TO -6 JIC

2940-088 HYDRAULIC HOSE & FITTINGS KIT



2940-089 HYDRAULIC HOSE & FITTINGS KIT



Yetter Hydraulic Compressor Installation

Step 3: Hydraulic Hose and Fittings Installation to the Compressor

Tool required: An assortment of standard wrenches & crescent wrench.

- A) Remove the cap from the – 6 port (also labeled P on the Hydraulic Control Block) & install the 2515-431 – 6 ORB (O-Ring Boss) to – 6 JIC straight adaptor fitting so that the O-Ring end goes into the hydraulic block & the JIC end faces away from the block. Install 1) 2515-831 3/8 – 6 10ft hydraulic hose to that fitting.
- B) Remove the cap from the – 8 port (also labeled T on the Hydraulic Control Block) & install the 2515-833 – 8 ORB to – 8 JIC straight adaptor fitting so that the O-Ring end goes into the hydraulic block & the JIC end faces away from the block. Install the 2515-832 1/2 – 8 10ft hydraulic hose to that fitting.



- C) Remove cap plug from – 4 port on the motor (this is the Case Drain) using a 3/16 hex key wrench if equipped with threaded plug (may also have rubber plug) & install the 2515- 848 –4 ORB to – 6 JIC 90 degree adaptor fitting so that the O-Ring end goes into the hydraulic motor & the JIC end faces downward. Install 1) 2515-831 3/8 – 6 10ft hydraulic hose to that fitting.



Control Box to Yetter Compressor Wiring Installation

Step 1: Install the 2940-181 Solenoid/Pressure Switch Control Harness on the compressor.

Step 2: Install the 2940-189 between the 2940-181 and the 4 pin connector on the side of the 2940-103A control box.

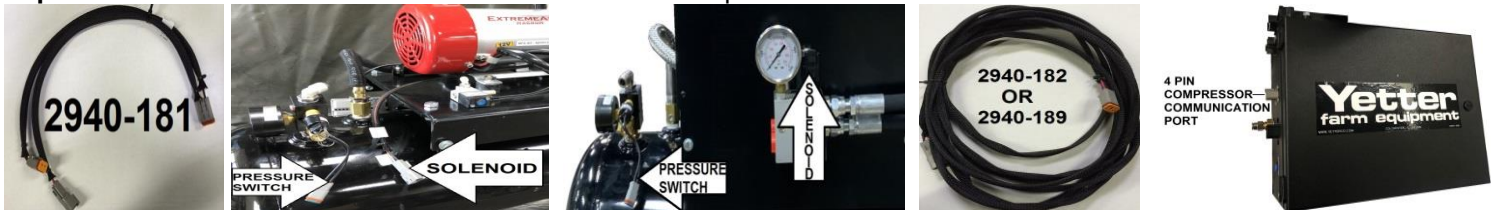

2940-114 Stand Alone Compressor Wiring Kit Installation

Step 1: Install the 2940-518 Cab Switch harness in the tractor cab. Mount the Switch in an area easily accessible. The 2 bare wires need spliced to the OEM Switched Power Connector (not supplied), & the female 2 pin Deutsch routes to tractor hitch.

Step 2: From the 2 pin female Deutsch of the 2940-518 at the hitch, install as many 2940-154 (30ft extension) harnesses as need to reach the compressor.

Step 3: Install the 2940-525 at compressor as labeled in photo below. Install the 2940-154 into the remaining open connector.



Yetter Hydraulic Compressor Installation

Step 4: Hydraulic Connection

There are 2 ways to supply hydraulic flow to the compressor: an open SCV on the tractor or plumbing into a planter circuit. If plumbing into a planter's circuit, the circuit must have constant hydraulic flow when the planter is in use. Always plumb between the tractor's SCV & the hydraulic block on the planter. Plumbing downstream of the hydraulic block may cause inconsistent flow to all functions driven by that hydraulic circuit. **PTO driven & power beyond hydraulic circuits are NOT to be used when plumbing the Yetter hydraulic compressor.** When running, the Yetter hydraulic compressor requires a maximum of 4 gallons per minute. The 2940-088 hydraulic fittings kit is used to tie into a planter circuit & 2940-089 hydraulic fittings kit is for using an open SCV remote on the tractor. In some applications, more fittings & longer hydraulic hoses may need purchased to make the hydraulic connection. It is recommended to use 1 hydraulic hose from the compressor to the location where the connection is made, splicing hoses together cause more potential leak points. If teeing into the lift/lower & bulk fill fan on a John Deere planter, plumb the Yetter hydraulic compressors pressure circuit into the planter's return circuit (usually labeled V2A on the hydraulic block) & plumb the Yetter hydraulic compressor return circuit into the planter's pressure circuit (usually labeled V1A on the hydraulic block). Additional hydraulic plumbing pictures may be acquired by calling Yetter service, 800-447-5777.

BULKHEAD ON DB PLANTERS



SCV DIRECT



HYDRAULIC BLOCK AT THE REAR OF THE PLANTER



TEERING BEHIND PIONEER COUPLER

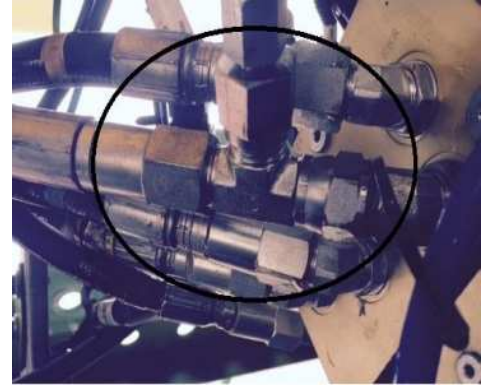

KINZE 4900



Step 6: Connect the hydraulic hose attached to case drain on the motor to case drain connector on the tractor or by teeing into a case drain circuit on the planter. Below are a few examples of hydraulic connection. The Yetter hydraulic compressor is equipped with a case drain port on the motor. Case Drain is a pressure free circuit that provides a flow path to the reservoir for hydraulic fluid used to cool & lubricate the motor. Make sure to connect the case drain to the reservoir where the hydraulic flow to the compressor is received. If tractor isn't equipped with case drain, a kit may be purchased from the OEM tractor dealer.

CASE DRAIN FLAT FACE COUPLERS CONNECTED AT TRACTOR



TEE INTO EXISTING CASE DRAIN

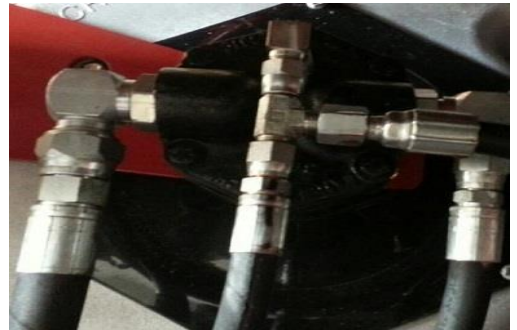

NOTE: THESE ARE EXAMPLES ONLY. USE YOUR BEST JUDGEMENT TO FIT YOUR SITUATION

Airline Routing –Compressor to Control Box

Yetter Compressor

- Step 1:** Install 2940-367 250psi rated 3/8 airline from compressor outlet to inlet (water trap side labeled A) of water separator
- Step 2:** Install 2940-345 3/8" black airline from outlet port of water separator (labeled B) to inlet port (labeled 1) on control box
- Step 3:** Route 1/4" airline from 1/4"PTC elbow (labeled C) on water separator to 1/4"PTC fitting (labeled 2) on **BOTTOM** of control box
- Step 4:** Route 1/4" airline from the 1/4"PTC fitting (labeled 3) on side of control box toward the ground making sure the end of the airline is not pointed toward anything that moisture may damage or rust

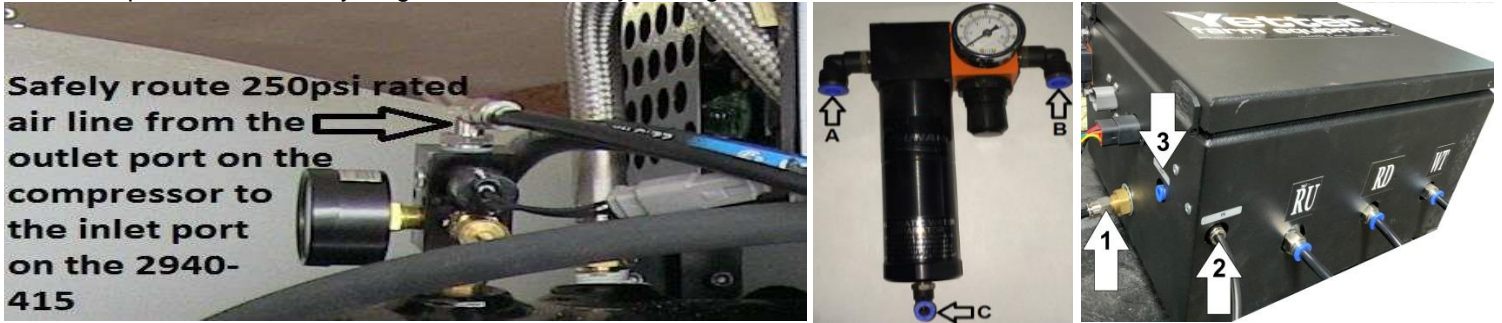

Yetter Compressor Communication Harness

- Step 1:** Install 2940-181 compressor solenoid/switch harness; male 2 pin connector installs into female connector on On/Off solenoid, female 2 pin connector installs into male 2 pin connector on pressure switch.
- Step 2:** Connect the 2940-189 (10ft) control harness to 4 pin connector of the 2940-181 & route to control box. If more length is needed, call Yetter & order more. (2940-182 is 20ft length; 2940-189 is 10ft length)
- Step 3:** Connect the 2940-182 or 2940-189 into the 4 pin female connector on side of the control box.



John Deere Hydraulic Compressor

- Step 1:** Locate the manifold block on the hyd. comp., drain air pressure from tank/manifold block, & remove gauge/pipe plug
- Step 2:** If pipe plug equipped, install 2940-408 3/8 PTC elbow where plug was removed. If gauge equipped, install 2940-374 adaptor; Male end gets Teflon tape & installs on manifold block, gauge installs in rearward facing female end, & 2940-408 3/8PTC elbow installs in remaining end
- Step 3:** Install 2940-367-250psi rated 3/8 airline from the 3/8 PTC elbow fitting to the inlet port (labeled A) of water separator
- Step 4:** Route 2940-345 black 3/8"airline from outlet port (labeled B) of water separator to inlet port (labeled 1) on control box
- Step 5:** Route 1/4" airline from 1/4"PTC elbow (labeled C) on water separator to 1/4"PTC fitting (labeled 2) on **BOTTOM** of control box
- Step 6:** Route 1/4" airline from the 1/4"PTC fitting (labeled 3) on side of control box toward the ground making sure the end of the airline is not pointed toward anything that moisture may damage or rust



PIPE PLUG ONLY

GAUGE INSTALLED

Airline Routing –Compressor to Control Box

Precision Planting Hydraulic Compressor

Step 1: Drain all tank pressure from Precision Planting hyd. comp. & install a Tee in the airline that routes from top of tank to the water separator. (as indicated by arrow below)

Step 2: Install 2940-367 250psi rated 3/8" airline from the installed Tee to the inlet (labeled A) of the Yetter water separator

Step 3: Install 2940-345 3/8" black airline from outlet port (labeled B) on water separator to inlet port (labeled 1) on control box

Step 4: Route 1/4" airline from 1/4"PTC elbow (labeled C) on water separator to 1/4"PTC fitting (labeled 2) on **BOTTOM** of control box

Step 5: Route 1/4" airline from the 1/4"PTC fitting (labeled 3) on side of control box toward ground making sure the end of the airline is not pointed toward anything that moisture may damage or rust

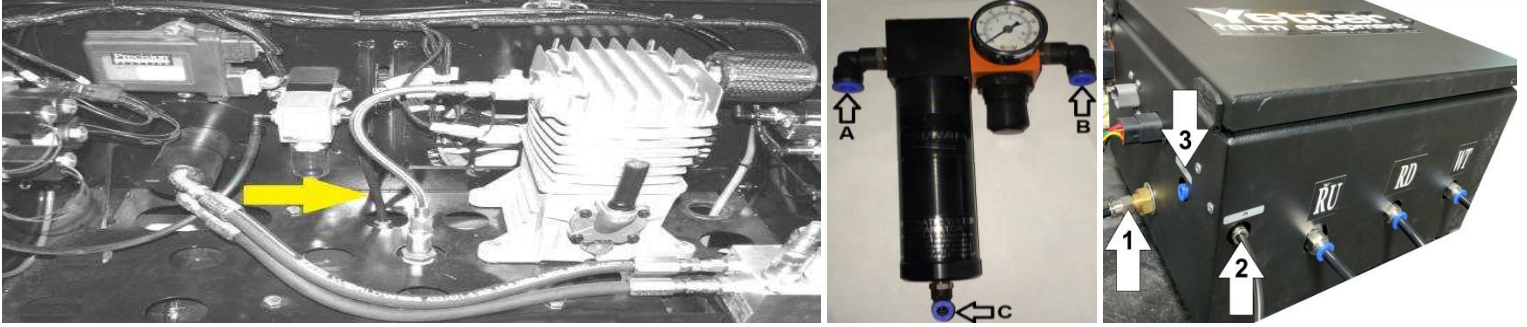

Case Hydraulic Compressor

Step 1: Drain all tank pressure from Case hyd. comp. Plumb into compressor by either installing a Tee in airline that routes from top of tank to valve manifold (as indicated by arrow) or by installing a 2940-408 in bung on side of compressor tank

Step 2: Route 2940-367 250psi rated 3/8" airline from the installed Tee to the inlet (labeled A) of the Yetter water separator

Step 3: Route 2940-345 3/8" black airline from outlet port (labeled B) on water separator to inlet port (labeled 1) on control box

Step 4: Route 1/4" airline from 1/4"PTC elbow (labeled C) on water separator to 1/4"PTC fitting (labeled 2) on **BOTTOM** of control box

Step 5: Route 1/4" airline from the 1/4"PTC fitting (labeled 3) on side of control box toward ground making sure the end of the airline is not pointed toward anything that moisture may damage or rust

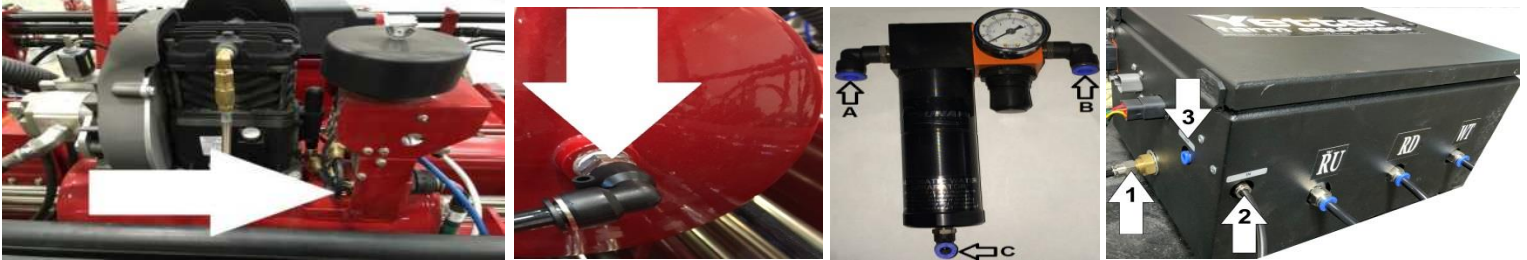

Airline Routing-Planter Frame

Below is a suggested method for safely & securely routing the airlines on the planter frame whether installing trunk airlines (airlines routing to the row cleaner air bags) or supply airlines (airlines that route from the control box to the trunk airlines). Safely route the airlines on the frame that the row units are mounted to or follow the path to which the hydraulic hoses on the planter are routed. After airline installation is complete & system is tested, use provided zip ties to keep parts away from pinch & wear points.



Airline Routing-Row Unit

Below is a suggested method for safely and securely routing the airlines from the air bag to the tees on the planter frame. These are generalizations & **YOU SHOULD USE YOUR OWN BEST JUDGEMENT** in routing airlines. DO NOT pass the airlines between the rear of the parallel arm & the row unit. DO NOT pass airlines between the frame & the head plate used to mount the row unit to the planter frame. These can act as both a pinch points & wear points. If necessary, use provided zip ties to keep airlines away from pinch & wear points & sharp or rotating objects that may damage the airline.



Specific airline routing will be dependent upon: Row unit make & model (AGCO, CNH, JD, Kinze, etc), row unit spacing (15", 20", 22", 30", 36", etc), parallel arm length, & other variables. RM units will have 1 up pressure & 1 down pressure air bag & RM/Coulter Combo models will have 2 air bags on the bottom of the bracket for up pressure & a single air bag on top is for down pressure. The 2 up pressure air bags will have airline connected together so the lift pressure trunk airlines will need plumbed to that Wye.

Airline Routing

The following pages are airline diagrams of different planter models. The wiring/tubing kit will have everything needed to complete installation. The # of rows used on center section will vary based on row spacing & style of planter. Examples, narrow transport 30" spacing planters will only have 4 center section rows. 20" spacing planters usually have 10 rows.

Direction of flow is: Supply Tank → Water Separator Assembly → Control Box → Air Bags All airlines will be 3/8". Blue airline should be used on all lift pressure air bags & black airline should be used on all down pressure air bags. Use the airline colors to differentiate the lift pressure (Blue Airline) and down pressure (Black Airline) on the planter for troubleshooting & leak detection indication. Route the airlines as efficiently and conveniently as possible.

If there is no diagram for your situation, contact a Yetter service representative (800-447-5777) and a drawing will be made.

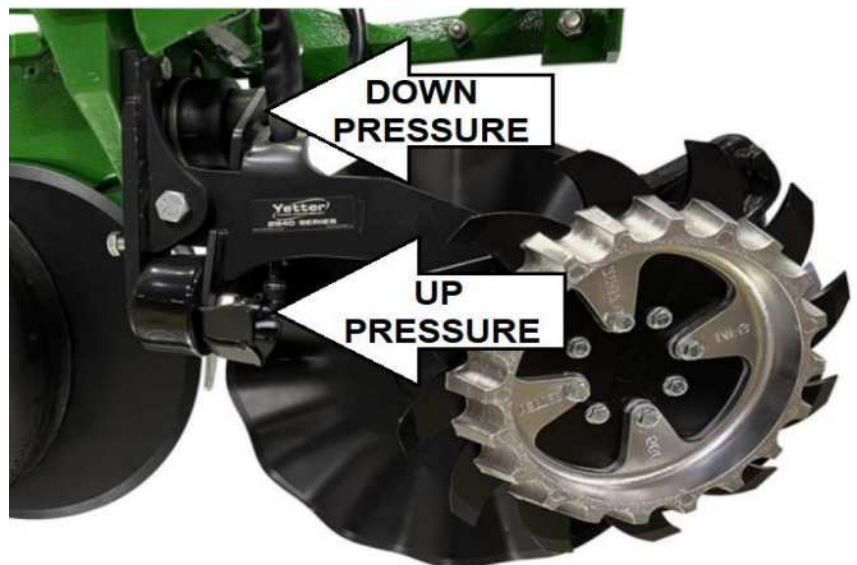
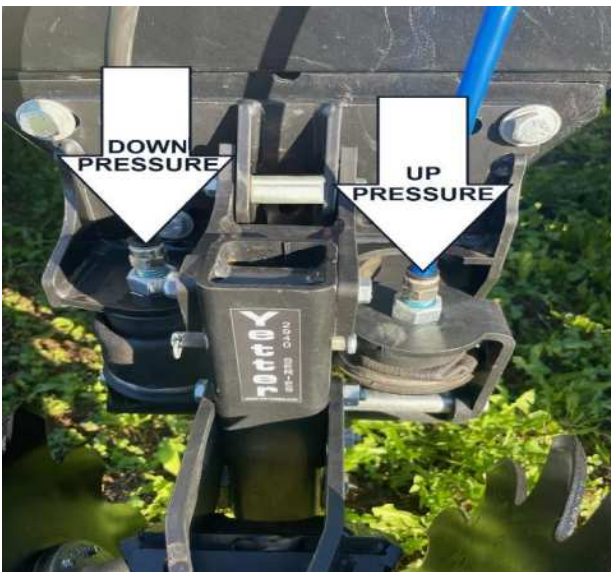

6 Row Airline Diagram

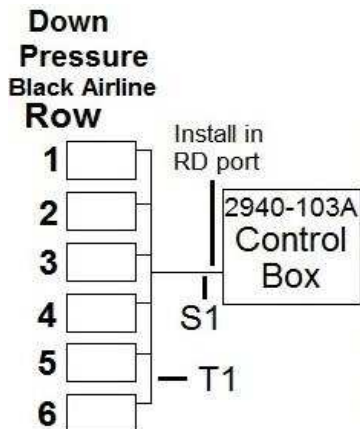

Step 1: T1 & T2 Route blue & black airline from row 1 to row 6. Install the black airline in the down pressure air bag & the blue airline in the up pressure air bag. Trace both airlines back to row 1 installing tees in each (blue & black) airline at each row unit. From each tee in the up pressure (blue airline) circuit, route blue airline to the up pressure air bag and install in the fitting. From each tee in the down pressure (black airline) circuit, route black airline to the down pressure air bag and install in the fitting. When back to row 1, cut each airline to length & install each airline into the matching air bag.

Step 2: S1 Install a tee near center of the planter in the black airline installed in step 1. Install black airline from the open port on the tee to the RD port on the bottom of the 2940-103A control box.

Step 3: S2 Install a tee in the blue airline installed in step 1 near center of the planter. Install blue airline from open port on the tee to the RU port on the bottom of the 2940-103A control box.

Step 4: Install a plug (2940-352) into the WT port on 2940-103A control box to prevent air loss. Another way to do this is to cut a 6inch piece of black airline, install one end into the WT port, fold the airline over causing a kink, & zip tie the airline to stay like this. This circuit will not be used with this size of planter.

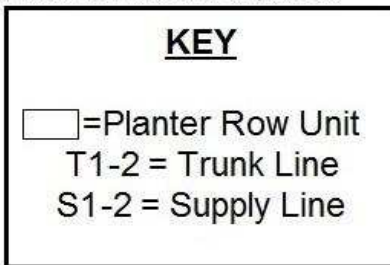
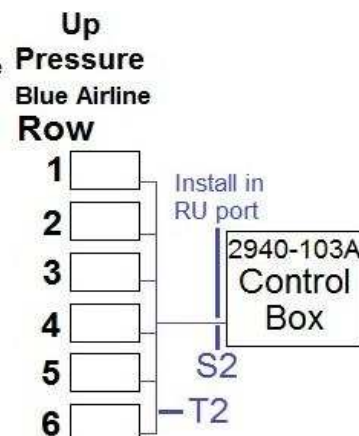

6/11 or 6/12 Split Row Airline Diagram

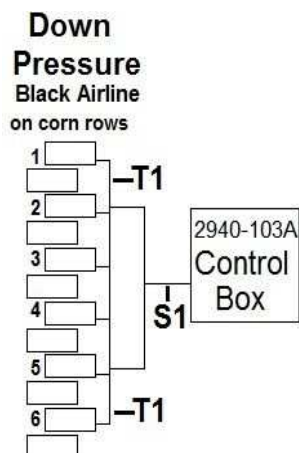

KEY

○ = Ball Valve

□ = Planter Row Unit

S1-2 = Supply Airline

T1-4 = Trunk Airline

Step 1: T1 & T2 Route black & blue airline from the first corn row to the last corn row. Install the black airline in the fitting of the down pressure air bag & the blue airline in the fitting of the up pressure air bag on the last corn row. Trace both airlines back to the first corn row installing tees in each airline at each corn row. Route & install blue airline from the up pressure air bag fitting to the tee in the up pressure (blue) circuit for that corn row. Route & install black airline from the down pressure air bag fitting to the tee in the down pressure (black) circuit for that corn row. When back to the first corn row, cut each airline to length & install each airline into the fitting of the matching air bag.

Step 2: S1 Cut & install a tee at corn rows 2 & 5 of the T1 down pressure airline installed in step 1. Install black airline from the remaining port on each tee & route to center of planter using a tee to connect the 2 black airlines together. Route & install black airline from the remaining open port in that tee to the RD port on 2940-103A control box.

Step 3: S2 Cut & install a tee at corn rows 2 & 5 of the T2 up pressure airline installed in step 1. Install blue airline from the remaining port on each tee & route to center of planter using a tee to connect the 2 blue airlines together. Route & install blue airline from the remaining open port in that tee to the RU port on 2940-103A control box.

Step 4: T3 & T4 Route black & blue airline from the first split row to the last split row. Install the black airline in the fitting of the down pressure air bag & the blue airline in the fitting of the up pressure air bag on the last split row. Trace both airlines back to the first split row installing tees in each airline at each split row. Route & install blue airline from the up pressure air bag fitting to the tee in the up pressure (blue) circuit for that split row. Route & install black airline from the down pressure air bag fitting to the tee in the down pressure (black) circuit for that split row. When back to the first split row, cut each airline to length & install each airline into the fitting of the matching air bag.

Step 5: Cut & install a tee at split rows 2 & 5 into the T3 down pressure airline installed in step 4. Cut & install a tee in the S1 airline near split rows 2 & 5. Install black airline from the remaining port in the tee next to split row 2 & the remaining port in the S1 airline near split row 5.

Step 6: Cut & install a tee at split rows 2 & 5 into the T4 up pressure airline installed in step 4. Cut & install a tee in the S2 airline near split rows 2 & 5. Install blue airline from the remaining port in the tee next to split row 2 & the remaining port in the S2 airline near split row 5.

Step 7: Ball Valve Install a ball valve (2940-342) in each of the S1 & S2 airlines that supply the split rows' trunk airline. These ball valves are used to turn air off to split rows when planting corn.

Step 8: Install a plug (2940-352) provided in spare fittings bag (2940-174) in the WT port on the 2940-103A control box.

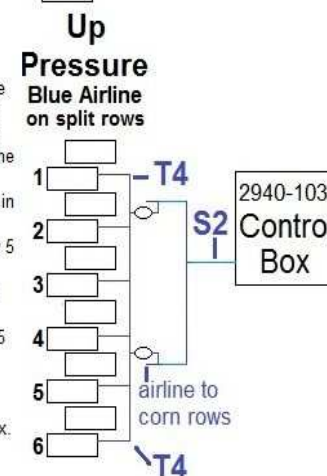
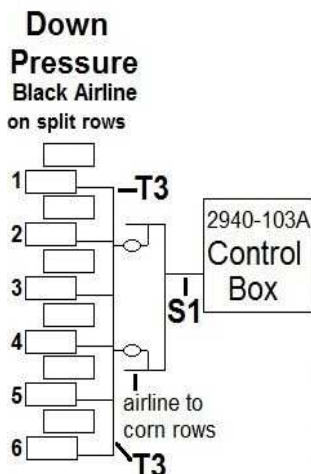
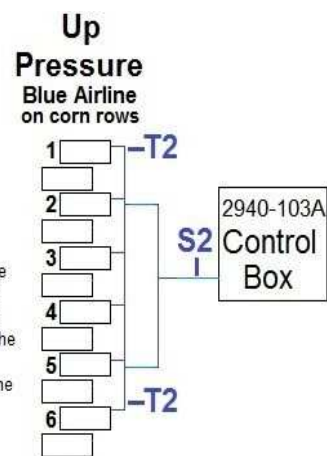

8 Row Airline Diagram

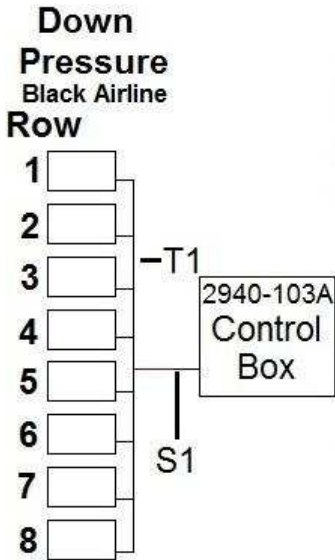

Step 1: T1 & T2 Route blue & black airline from row 1 to row 8. Install the black airline in the down pressure air bag & blue airline in the up pressure air bag. Trace both airlines back to row 1 installing tees in each (blue & black) airline at each row unit. From each tee in the up pressure (blue airline) circuit, route blue airline to the up pressure air bag & install in the fitting. From each tee in the down pressure (black airline) circuit, route black airline to the down pressure bag & install in the fitting. When back to row 1, cut each airline to length & install each airline to the matching air bag.

Step 2: S1 Install a tee near the center of the planter in the black airline installed in step 1. Install black airline from the open port on the tee to the RD port on the bottom of the 2940-103A control box.

Step 3: S2 Install a tee near the center of the planter in the blue airline installed in step 1. Install blue airline from the open port on the tee to the RU port on the bottom of the 2940-103A control box.

Step 4: Install a plug (2940-352) into the WT port on the 2940-103A control box to prevent air loss. Another way to do this is to cut a 6inch piece of black airline, install one end into the WT port, fold the airline over causing a kink, & zip tie the airline to stay like this. This circuit will not be used with this size of planter.

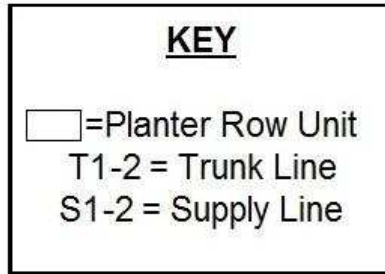
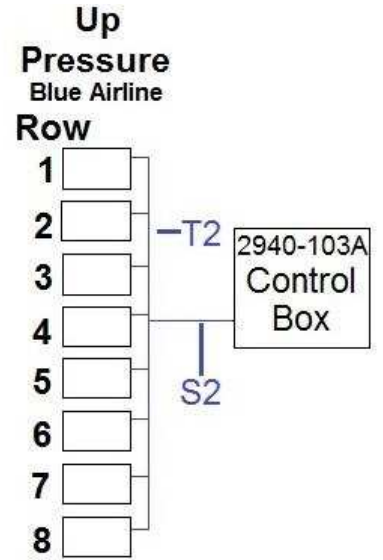

8/15 & 8/16 Split Row Airline Diagram

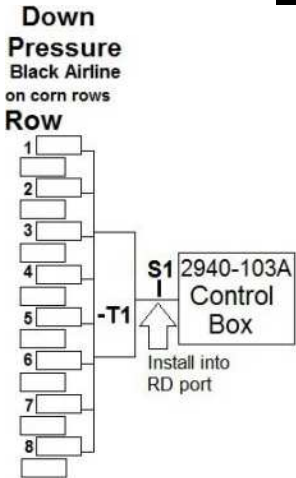

Step 1: T1 & T2 Route black & blue airline from the first corn row to the last corn row. Install the black airline in the fitting of the down pressure air bag & the blue airline in the fitting of the up pressure air bag on the last corn row. Trace both airlines back to the first corn row installing tees in each airline at each corn row. Route & install blue airline from the up pressure air bag fitting to the tee in the up pressure (blue) circuit for that corn row. Route & install black airline from the down pressure air bag fitting to the tee in the down pressure (black) circuit for that corn row. When back to the first corn row, cut each airline to length & install each airline into the fitting of the matching air bag.

Step 2: S1 Cut & install a tee at corn rows 3 & 6 of the T1 down pressure airline installed in step 1. Install black airline from the remaining port on each tee & route to center of planter using a tee to connect the 2 black airlines together. Route & install black airline from the remaining open port in that tee to the RD port on 2940-103A control box.

Step 3: S2 Cut & install a tee at corn rows 3 & 6 of the T2 up pressure airline installed in step 1. Install blue airline from the remaining port on each tee & route to center of planter using a tee to connect the 2 blue airlines together. Route & install blue airline from the remaining open port in that tee to the RU port on 2940-103A control box.

Step 4: T3 & T4 Route black & blue airline from the first split row to the last split row. Install the black airline in the fitting of the down pressure air bag & the blue airline in the fitting of the up pressure air bag on the last split row. Trace both airlines back to the first split row installing tees in each airline at each split row. Route & install blue airline from the up pressure air bag fitting to the tee in the up pressure (blue) circuit for that split row. Route & install black airline from the down pressure air bag fitting to the tee in the down pressure (black) circuit for that split row. When back to the first split row, cut each airline to length & install each airline into the fitting of the matching air bag.

Step 5: Cut & install a tee at split rows 3 & 6 into the T3 down pressure airline installed in step 4. Cut & install a tee in the S1 airline near split rows 3 & 6. Install black airline from the remaining port in the tee next to split row 3 & the remaining port in the S1 airline near split row 3. Install black airline from the remaining port in the tee next to split row 6 & the remaining port in the S1 airline near split row 6.

Step 6: Cut & install a tee at split rows 3 & 6 into the T4 up pressure airline installed in step 4. Cut & install a tee in the S2 airline near split rows 3 & 6. Install blue airline from the remaining port in the tee next to split row 3 & the remaining port in the S2 airline near split row 3. Install blue airline from the remaining port in the tee next to split row 6 & the remaining port in the S2 airline near split row 6.

Step 7: Ball Valve Install a ball valve (2940-342) in each of the S1 & S2 airlines that supply the split rows' trunk airline. These ball valves are used to turn air off to split rows when planting corn.

Step 8: Install a plug (2940-352) provided in the spare fittings bag (2940-174) in the WT port on the 2940-103A control box.

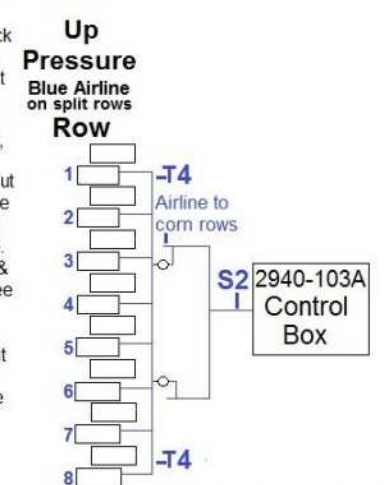
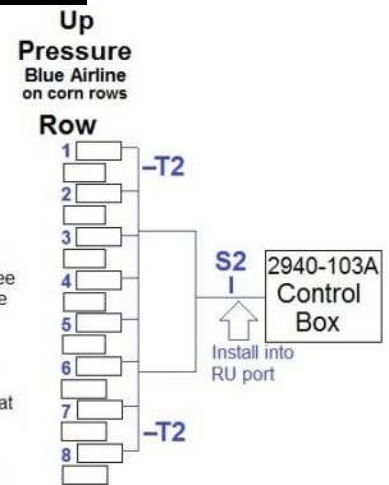
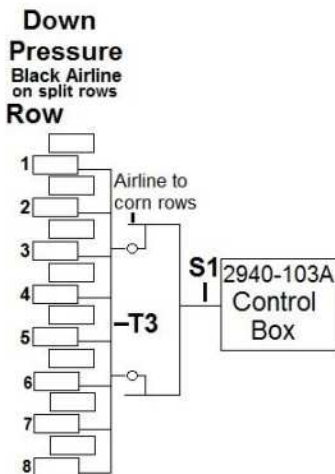

12 Row Airline Diagram

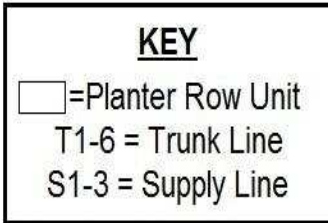

Down Pressure Black Airline

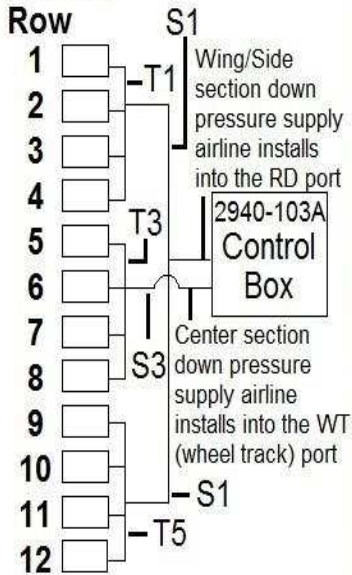

Step 1: T1 & T2 Route blue & black airline from row 1 to row 4. At row 4, install the black airline in the down pressure air bag fitting & blue airline in the up pressure air bag fitting. Install a tee in each color of airline at rows 2 & 3. At each row, install blue airline from the up pressure air bag to the tee in the blue airline & install black airline from the down pressure air bag to the tee in the black airline. At row 1, cut both airlines to length & install each airline into the matching air bag fitting.

Step 2: T3 & T4 Route blue and black airline from row 5 to row 8. Install each airline at row 8 into the matching air bag's fitting. Trace both airlines back to row 5 installing a tee in each airline at rows 6 & 7. Install blue airline from the up pressure air bag fitting to the tee in blue airline on rows 6 & 7. Install black airline from the down pressure air bag fitting to the tee in the black airline on rows 6 & 7. At row 5, cut both airlines to length and install into the matching air bag.

Step 3: T5 & T6 Route blue and black airline from row 12 to row 9. At row 9, install each airline into the matching air bag's fitting. Install a tee in each color of airline at row 10 & 11. Install blue airline from the up pressure air bag fitting to the tee in the blue airline & black airline from the down pressure air bag fitting to the tee in the black airline at each row. At row 12, cut both airlines to length and install each airline into the matching air bag fitting.

Step 4: S1 Cut & install a tee in the center of the T1 & T5 trunk airline. Route & install black airline from RD port of the 2940-103A control box to the nearest point on the main frame that the seed units are mounted to & install a tee. From each side of the tee, route black airline to the open port on the tee in the middle of the T1 & T5 trunk airline.

Step 5: S2 Cut & install a tee in the center of the T2, T4, & T6 trunk airline. Route & install blue airline from RU port of the 2940-103A control box to the nearest point on the main frame that the seed units are mounted to & install a tee. From each side of the tee, route blue airline to the open port on the tee in the middle of the T2 & T6 trunk airline. Install a second tee in the S2 near the center of the planter. Install blue airline from the open port in the tee in the middle of the T4 to the open port in the tee of the S2 airline.

Step 6: S3 Install a tee in the center of the T3 airline. Route & install black airline from the WT port of the 2940-103A control box to the open port in the tee in the T3 airline.

Up Pressure Blue Airline

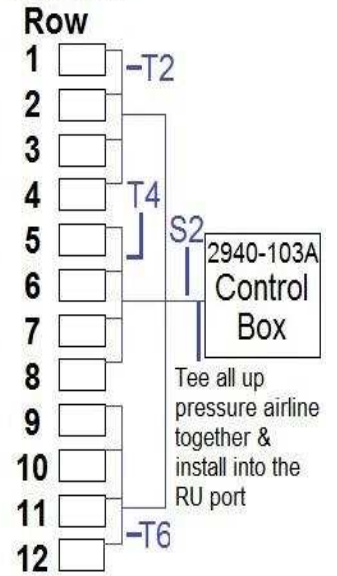

12/23 & 12/24 Split Row Airline Diagram

Down Pressure
Black Airline
on corn rows

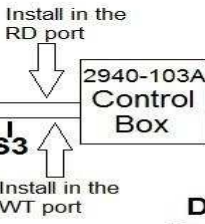
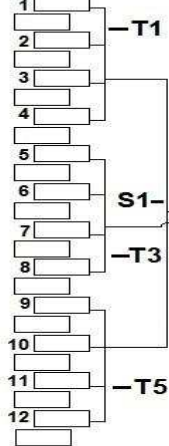

KEY
 □ = Planter Row Unit
 ○ = Ball Valve
 T1-12 = Trunk Line
 S1-3 = Supply Line

Up Pressure
Blue Airline
on corn rows

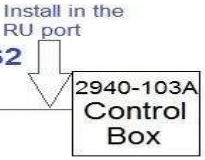
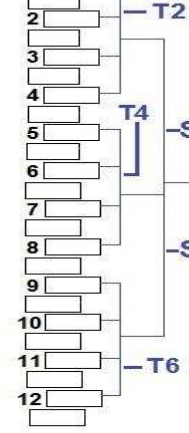

Down Pressure
Black Airline
on split rows

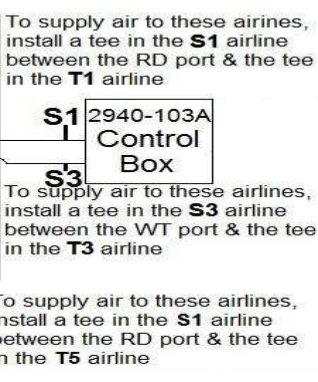
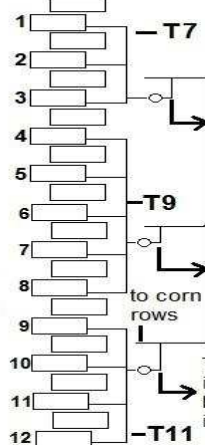

Up Pressure
Blue Airline
on split rows

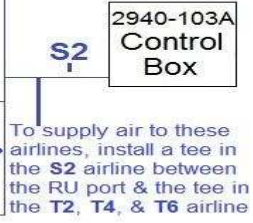
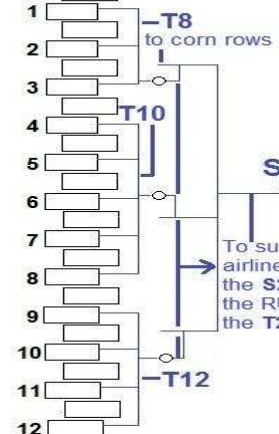

- Step 1: T1 & T2** Route black & blue airline from corn row 1 to corn row 4. At corn row 4, install the black airline into the down pressure air bag fitting & the blue airline in the up pressure air bag fitting. Trace both airlines back to corn row 1, installing a tee in each airline at corn rows 2 & 3. At corn row 1, cut both airlines to length & install the black airline in the down pressure air bag fitting & the blue airline in the up pressure air bag fitting. At corn rows 2 & 3, install blue airline from the up pressure air bag to the tee in the blue airline & install black airline from the down pressure air bag to the tee in the black airline.
- Step 2: T3 & T4** Route black & blue airline from corn row 5 to corn row 8. At corn row 8, install the black airline into the down pressure air bag fitting & the blue airline in the up pressure air bag fitting. Trace both airlines back to corn row 5, installing a tee in each airline at corn rows 6 & 7. At corn row 5, cut both airlines to length & install the black airline in the down pressure air bag fitting & the blue airline in the up pressure air bag fitting. At corn rows 6 & 7, install blue airline from the up pressure air bag to the tee in the blue airline & install black airline from the down pressure air bag to the tee in the black airline.
- Step 3: T5 & T6** Route black & blue airline from corn row 9 to corn row 12. At corn row 12, install the black airline into the down pressure air bag fitting & the blue airline in the up pressure air bag fitting. Trace both airlines back to corn row 9, installing a tee in each airline at corn rows 10 & 11. At corn row 9, cut both airlines to length & install the black airline in the down pressure air bag fitting & the blue airline in the up pressure air bag fitting. At corn rows 10 & 11, install blue airline from the up pressure air bag to the tee in the blue airline & install black airline from the down pressure air bag to the tee in the black airline.
- Step 4: T7 & T8** Route black & blue airline from split row 1 to split row 3 & install the black airline into the down pressure air bag fitting & the blue airline in the up pressure air bag fitting. Trace both airlines back to split 1, installing a tee in each airline at split row 2. At split row 1, cut both airlines to length & install the black airline in the down pressure air bag fitting & the blue airline in the up pressure air bag fitting. At split row 2, install blue airline from the up pressure air bag to the tee in the blue airline & install black airline from the down pressure air bag to the tee in the black airline.
- Step 5: T9 & T10** Route black & blue airline from split row 4 to split row 8 & install the black airline into the down pressure air bag fitting & the blue airline in the up pressure air bag fitting. Trace both airlines back to split 4, installing a tee in each airline at split rows 5-7. At split row 4, cut both airlines to length & install the black airline in the down pressure air bag fitting & the blue airline in the up pressure air bag fitting. At split rows 5-7, install blue airline from the up pressure air bag to the tee in the blue airline for that row & install black airline from the down pressure air bag to the tee in the black airline for that row.
- Step 6: T11 & T12** Route black & blue airline from split row 9 to split row 11/12 & install the black airline into the down pressure air bag fitting & the blue airline in the up pressure air bag fitting. Trace both airlines back to split 9, installing a tee in each airline at split rows 10 or 10 & 11. At split row 9, cut both airlines to length & install the black airline in the down pressure air bag fitting & the blue airline in the up pressure air bag fitting. At split rows 10 or 10 & 11, install blue airline from the up pressure air bag to the tee in the blue airline for that row & install black airline from the down pressure air bag to the tee in the black airline for that row.
- Step 7: S1** Install a tee in the middle of the T1 & T5 airline. From the open port on each tee, route & install black airline to the center of the planter & connect the two airlines using a tee. From the open port on this tee, route & install black airline to the RD port on the 2940-103A control box. Install a tee in the middle of the T7 & T11 airline. From the open port on each tee, route & install black airline to the nearest location on the planter that the S1 airline is. Install a tee in the S1 to connect T7 & T11 airline to S1 airline.
- Step 8: S2** Install a tee in the middle of the T2, T4, & T6 airline. Route & install blue airline from the open port of the tee in the T2 & T6 airline to the center of the planter & connect the two airlines using a tee. Install blue airline from the open port on the tee to the tee in the T4 airline. Cut & install another tee next to the tee that connects the T2, T4, & T6 airline. Install blue airline between the open port on this tee to the RU port on the 2940-103A control box. Install a tee in the middle of the T8, T10, & T12 airline. Route & install blue airline from the open port of each tee to the nearest location on the planter that the S2 airline is. Install a tee in the S2 to connect T8, T10, & T12 airline.
- Step 9: S3** Install a tee in the T3 & T9 airline. Install black airline from the tee in the T3 airline to the WT port on the 2940-103A control box. Install a tee in the S3 airline at the nearest location to the tee in the T9 airline & install black airline between the two tees.
- Step 10 Ball Valves** Install a ball valve in the black airline that connects each of the T7 & T11 to the S1 airline. Install a ball valve in the blue airline that connects each of the T8, T10, & T12 to the S2 airline. Install a ball valve in the black airline that connects the T9 to the S1 airline.

16 Row Airline Diagram

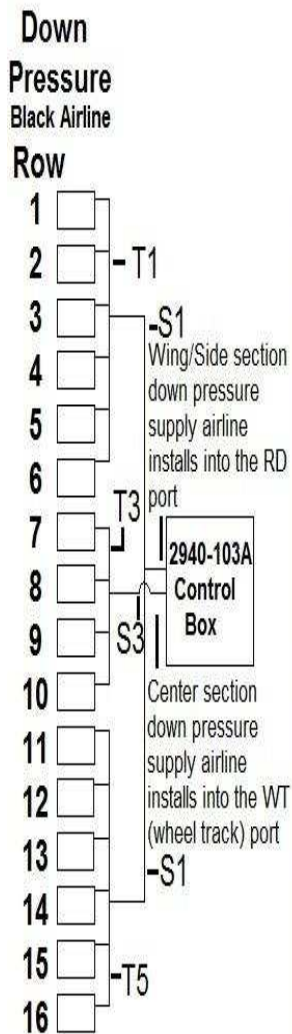
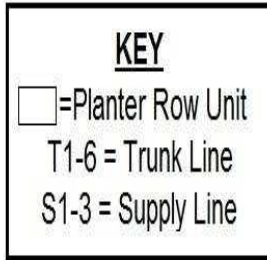

Step 1: T1 & T2 Route blue & black airline from row 1 to row 6. At row 6, install the black airline in the down pressure air bag fitting & blue airline in the up pressure air bag fitting. Install a tee in each color of airline at rows 2, 3, 4, & 5. At each of these rows, install blue airline from the up pressure air bag to the tee in the blue airline & install black airline from the down pressure air bag to the tee in the black airline. At row 1, cut both airlines to length & install each airline into the matching air bag fitting.

Step 2: T3 & T4 Route blue and black airline from row 7 to row 10. Install each airline at row 10 into the matching air bag's fitting. Trace both airlines back to row 7 installing a tee in each airline at rows 8 & 9. Install blue airline from the up pressure air bag fitting to the tee in blue airline on rows 8 & 9. Install black airline from the down pressure air bag fitting to the tee in the black airline on rows 8 & 9. At row 7, cut both airlines to length and install into the matching air bag.

Step 3: T5 & T6 Route blue and black airline from row 16 to row 11. At row 11, install each airline into the matching air bag's fitting. Install a tee in each color of airline at rows 12-15. At each of these rows, install blue airline from the up pressure air bag fitting to the tee in the blue airline & black airline from the down pressure air bag fitting to the tee in the black airline. At row 16, cut both airlines to length and install each airline into the matching air bag fitting.

Step 4: S1 Cut & install a tee in the center of the T1 & T5 trunk airline. Route & install black airline from RD port of the 2940-103A control box to the nearest point on the main frame that the seed units are mounted to & install a tee. From each side of the tee, route black airline to the open port on the tee in the middle of the T1 & T5 trunk airline.

Step 5: S2 Cut & install a tee in the center of the T2, T4, & T6 trunk airline. Route & install blue airline from RU port of the 2940-103A control box to the nearest point on the main frame that the seed units are mounted to & install a tee. From each side of the tee, route blue airline to the open port on the tee in the middle of the T2 & T6 trunk airline. Install a second tee in the S2 near the center of the planter. Install blue airline from the open port in the tee in the middle of the T4 to the open port in the tee of the S2 airline.

Step 6: S3 Install a tee in the center of the T3 airline. Route & install black airline from the WT port of the 2940-103A control box to the open port on the tee in the T3 airline.

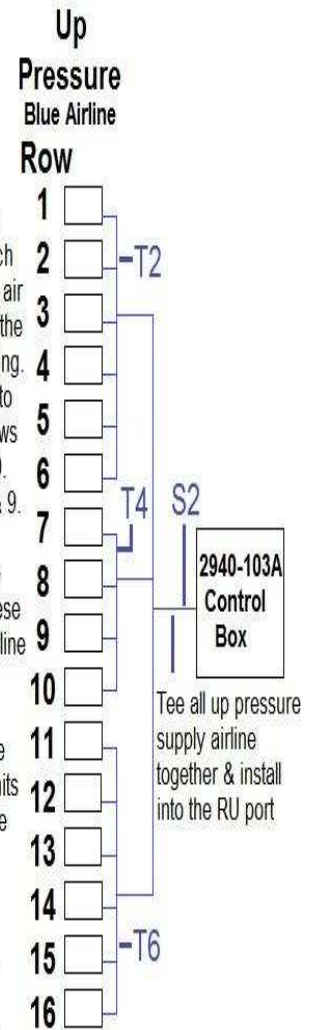

16/31 & 16/32 Split Row Airline Diagram

Down Pressure
Black Airline
on corn rows

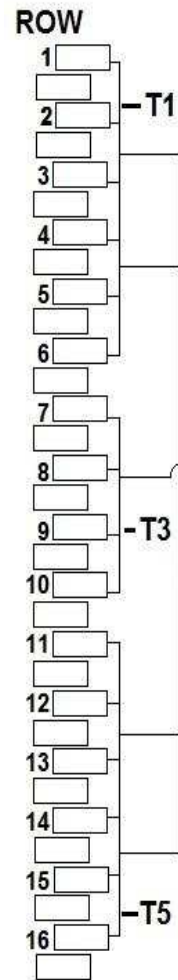

KEY

- = Planter Row Unit
- = Ball Valve
- T1-12 = Trunk Line
- S1-3 = Supply Line

Down Pressure
Black Airline
on split rows

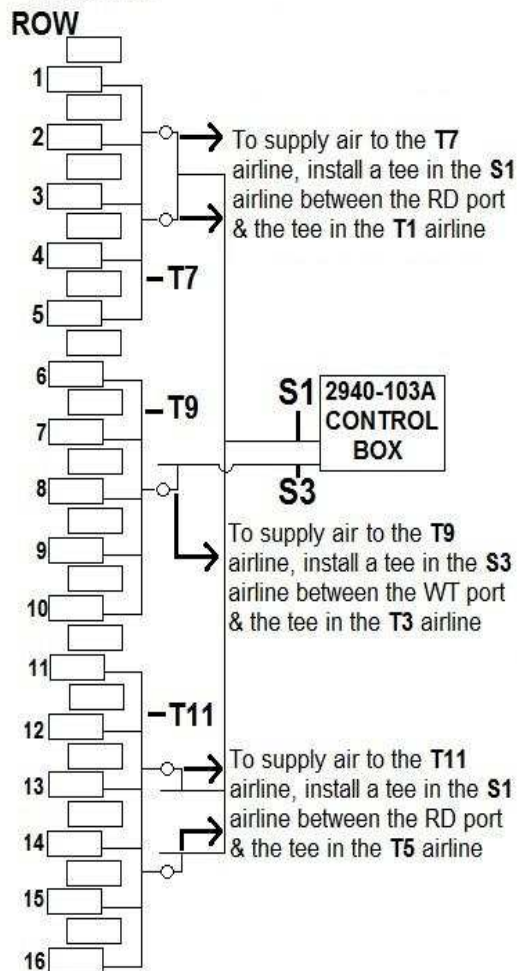

Up Pressure
Blue Airline
on corn rows

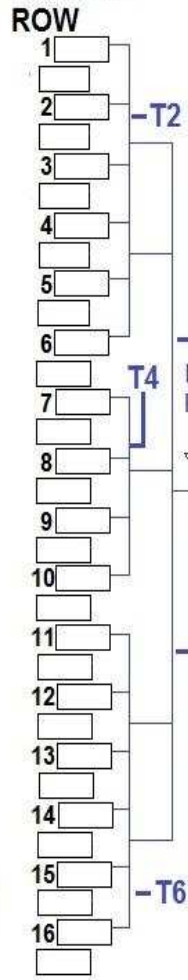

Up Pressure
Blue Airline
on split rows

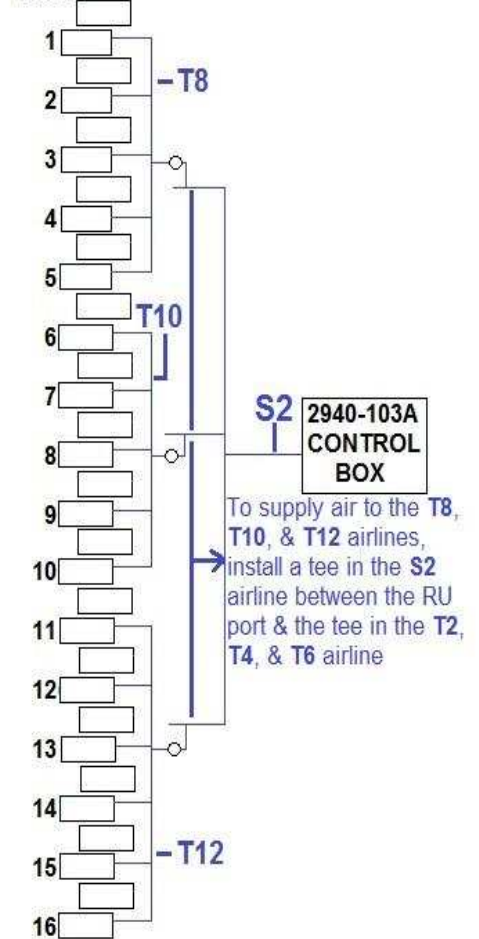

16/31 & 16/32 Split Row Airline Diagram Con't

Step 1: T1 & T2 Route black & blue airline from corn row 1 to corn row 6. At corn row 6, install the black airline into the down pressure air bag fitting & the blue airline in the up pressure air bag fitting. Trace both airlines back to corn row 1, installing a tee in each airline at corn rows 2-5. At corn row 1, cut both airlines to length & install the black airline in the down pressure air bag fitting & the blue airline in the up pressure air bag fitting. At corn rows 2-5, install blue airline from the up pressure air bag to the tee in the blue airline & install black airline from the down pressure air bag to the tee in the black airline.

Step 2: T3 & T4 Route black & blue airline from corn row 7 to corn row 10. At corn row 10, install the black airline into the down pressure air bag fitting & the blue airline in the up pressure air bag fitting. Trace both airlines back to corn row 7, installing a tee in each airline at corn rows 8 & 9. At corn row 7, cut both airlines to length & install the black airline in the down pressure air bag fitting & the blue airline in the up pressure air bag fitting. At corn rows 8 & 9, install blue airline from the up pressure air bag to the tee in the blue airline & install black airline from the down pressure air bag to the tee in the black airline.

Step 3: T5 & T6 Route black & blue airline from corn row 11 to corn row 16. At corn row 16, install the black airline into the down pressure air bag fitting & the blue airline in the up pressure air bag fitting. Trace both airlines back to corn row 11, installing a tee in each airline at corn rows 12-15. At corn row 11, cut both airlines to length & install the black airline in the down pressure air bag fitting & the blue airline in the up pressure air bag fitting. At corn rows 12-15, install blue airline from the up pressure air bag to the tee in the blue airline & install black airline from the down pressure air bag to the tee in the black airline.

Step 4: T7 & T8 Route black & blue airline from split row 1 to split row 5 & install the black airline into the down pressure air bag fitting & the blue airline in the up pressure air bag fitting. Trace both airlines back to split 1, installing a tee in each airline at split rows 2-4. At split row 1, cut both airlines to length & install the black airline in the down pressure air bag fitting & the blue airline in the up pressure air bag. At split rows 2-4, install blue airline from the up pressure air bag to the tee in the blue airline & install black airline from the down pressure air bag to the tee in the black airline.

Step 5: T9 & T10 Route black & blue airline from split row 6 to split row 10 & install the black airline into the down pressure air bag fitting & the blue airline in the up pressure air bag fitting. Trace both airlines back to split 6, installing a tee in each airline at split rows 7-9. At split row 6, cut both airlines to length & install the black airline in the down pressure air bag fitting & the blue airline in the up pressure air bag fitting. At split rows 7-9, install blue airline from the up pressure air bag to the tee in the blue airline for that row & install black airline from the down pressure air bag to the tee in the black airline for that row.

Step 6: T11 & T12 Route black & blue airline from split row 11 to split row 15/16 & install the black airline into the down pressure air bag fitting & the blue airline in the up pressure air bag fitting. Trace both airlines back to split 11, installing a tee in each airline at split rows 12-14/15. At split row 11, cut both airlines to length & install the black airline in the down pressure air bag fitting & the blue airline in the up pressure air bag fitting. At split rows 12-14/15, install blue airline from the up pressure air bag to the tee in the blue airline for that row & install black airline from the down pressure air bag to the tee in the black airline for that row.

Step 7: S1 Install 2 tees in the **T1** (at rows 3 & 5) & **T5** (at rows 12 & 14) airline. Install black airline from the RD port in the 2940-103A control box to the center of the planter & install a tee. From the open port on each side of the tee, route & install black airline to the open port on each tee that was installed in the **T1** & **T5** airline (will need to use more tees). Install a tee in the middle of the **T7** (rows 2 & 4) & **T11** (rows 12 & 14) airline. From the open port on each tee, route & install black airline to the nearest location on the planter that the **S1** airline is. Install a tee in the **S1** to connect **T7** & **T11** airline to **S1** airline.

Step 8: S2 Install 2 tees in the **T2** (at rows 3 & 5) & **T6** (at rows 12 & 14) airline & 1 tee in the **T4** (at row 8) airline. Install blue airline from the RU port on the 2940-103A control box to the center of the planter & install a tee. From each side of the tee, install blue airline to the open port on each tee that was installed in the **T2**, **T4**, & **T6** airline (will need to use more tees). Install a tee in the middle of the **T8** (row 3), **T10** (row 8), & **T12** (row 13) airline. Route & install blue airline from the open port of each tee to the nearest location on the planter that the **S2** airline is. Install a tee in the **S2** to connect **T8**, **T10**, & **T12** airline to **S2** airline.

Step 9: S3 Install a tee in the **T3** (row 8) & **T9** (row 8) airline. Install black airline from the tee in the **T3** airline to the WT port on the 2940-103A control box. Install a tee in the **S3** airline at the nearest location to the tee in the **T9** airline & install black airline between the two tees.

Step 10 Ball Valves Install a ball valve in the black airline that connects each of the **T7** & **T11** to the **S1** airline. Install a ball valve in the blue airline that connects each of the **T8**, **T10**, & **T12** to the **S2** airline. Install a ball valve in the black airline that connects the **T9** to the **S1** airline.

24 Row Airline Diagram

Down
Pressure
Black Airline
Row

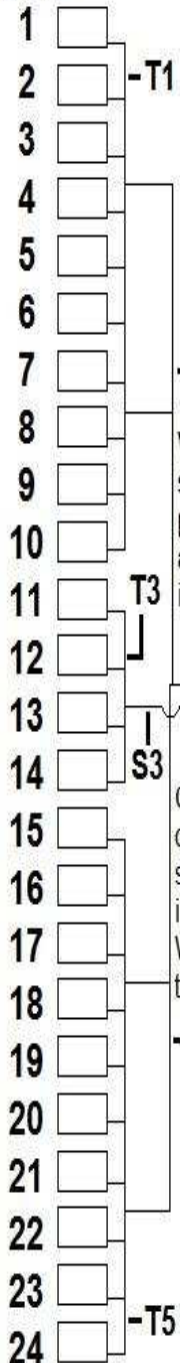

KEY

□ = Planter Row Unit

T1-6 = Trunk Line

S1-3 = Supply Line

Step 1: T1 & T2 Route blue & black airline from row 1 to row 10. At row 10, install the black airline in the down pressure air bag fitting & blue airline in the up pressure air bag fitting. Install a tee in each color of airline at rows 2-9. At each of these rows, install blue airline from the up pressure air bag to the tee in the blue airline & install black airline from the down pressure air bag to the tee in the black airline. At row 1, cut both airlines to length & install each airline into the matching air bag fitting.

Step 2: T3 & T4 Route blue and black airline from row 11 to row 14. Install each airline at row 14 into the matching air bag's fitting. Trace both airlines back to row 11 installing a tee in each airline at rows 12 & 13. Install blue airline from the up pressure air bag fitting to the tee in blue airline on rows 12 & 13. Install black airline from the down pressure air bag fitting to the tee in the black airline on rows 12 & 13. At row 11, cut both airlines to length and install into the matching air bag.

Step 3: T5 & T6 Route blue and black airline from row 24 to row 15. At row 15, install each airline into the matching air bag's fitting. Install a tee in each color of airline at rows 15-23. At each of these rows, install blue airline from the up pressure air bag fitting to the tee in the blue airline & black airline from the down pressure air bag fitting to the tee in the black airline. At row 24, cut both airlines to length and install each airline into the matching air bag fitting.

Step 4: S1 Cut & install a tee between rows 3/4 & 7/8 of the T1 airline & rows 17/18 & 21/22 of the T5 trunk airline. Route & install black airline from RD port of the 2940-103A control box to the nearest point on the main frame that the seed units are mounted to & install a tee. From each side of the tee, route black airline to the open port on each tee in the middle of the T1 & T5 trunk airline.

Step 5: S2 Cut & install a tee between rows 3/4 & 7/8 of the T2 airline, row 12/13 of the T4 airline, & rows 17/18 & 21/22 of the T6 airline. Route & install blue airline from RU port of the 2940-103A control box to the nearest point on the main frame that the seed units are mounted to & install a tee. From each side of the tee, route blue airline to the open port on each tee in the middle of the T2, T4, & T6 trunk airline.

Step 6: S3 Install a tee in the center of the T3 airline between rows 12/13. Route & install black airline from the WT port of the 2940-103A control box to the open port in the tee in the T3 airline.

Up
Pressure
Blue Airline
Row

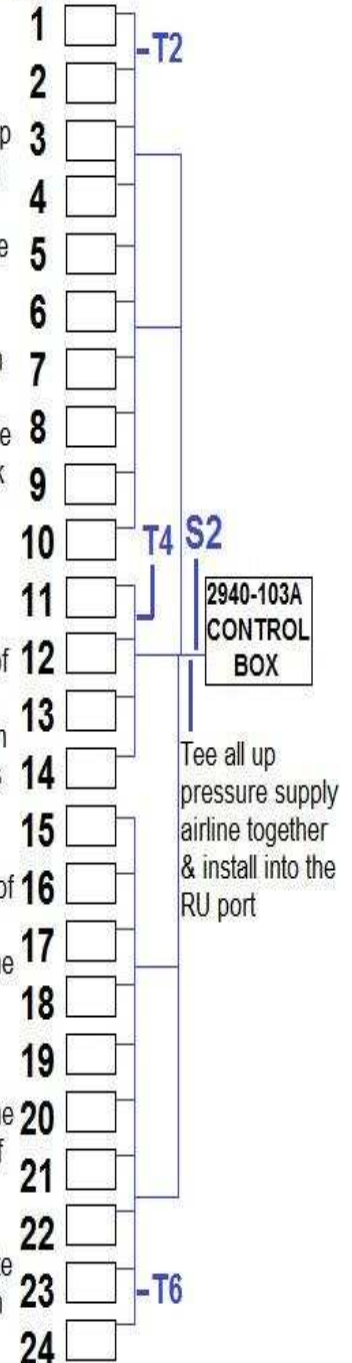

24/47 & 24/48 Row Airline Diagram

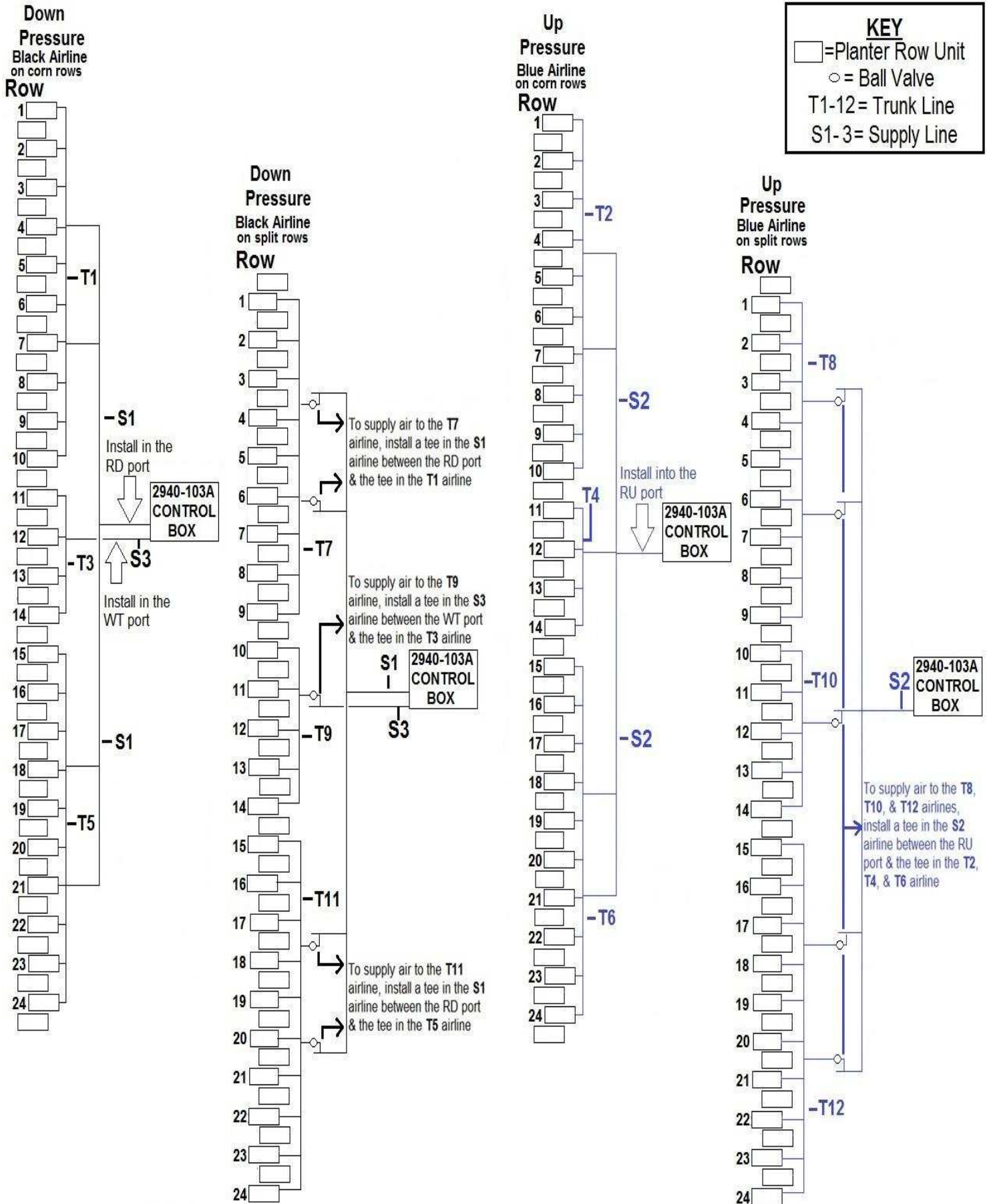

24/47 & 24/48 Row Airline Diagram Con't

Step 1: T1 & T2 Route black & blue airline from corn row 1 to corn row 10. At corn row 10, install the black airline into the down pressure air bag fitting & the blue airline in the up pressure air bag fitting. Trace both airlines back to corn row 1, installing a tee in each airline at corn rows 2-9. At corn row 1, cut both airlines to length & install the black airline in the down pressure air bag fitting & the blue airline in the up pressure air bag fitting. At corn rows 2-9, install blue airline from the up pressure air bag to the tee in the blue airline & install black airline from the down pressure air bag to the tee in the black airline.

Step 2: T3 & T4 Route black & blue airline from corn row 11 to corn row 14. At corn row 14, install the black airline into the down pressure air bag fitting & the blue airline in the up pressure air bag fitting. Trace both airlines back to corn row 11, installing a tee in each airline at corn rows 12 & 13. At corn row 11, cut both airlines to length & install the black airline in the down pressure air bag fitting & the blue airline in the up pressure air bag fitting. At corn rows 12 & 13, install blue airline from the up pressure air bag to the tee in the blue airline & install black airline from the down pressure air bag to the tee in the black airline.

Step 3: T5 & T6 Route black & blue airline from corn row 15 to corn row 24. At corn row 24, install the black airline into the down pressure air bag fitting & the blue airline in the up pressure air bag fitting. Trace both airlines back to corn row 15, installing a tee in each airline at corn rows 16-23. At corn row 15, cut both airlines to length & install the black airline in the down pressure air bag fitting & the blue airline in the up pressure air bag fitting. At corn rows 16-23, install blue airline from the up pressure air bag to the tee in the blue airline & install black airline from the down pressure air bag to the tee in the black airline.

Step 4: T7 & T8 Route black & blue airline from split row 1 to split row 9 & install the black airline into the down pressure air bag fitting & the blue airline in the up pressure air bag fitting. Trace both airlines back to split 1, installing a tee in each airline at split rows 2-8. At split row 1, cut both airlines to length & install the black airline in the down pressure air bag fitting & the blue airline in the up pressure air bag fitting. At split rows 2-8, install blue airline from the up pressure air bag to the tee in the blue airline & install black airline from the down pressure air bag to the tee in the black airline.

Step 5: T9 & T10 Route black & blue airline from split row 9 to split row 14 & install the black airline into the down pressure air bag fitting & the blue airline in the up pressure air bag fitting. Trace both airlines back to split 9, installing a tee in each airline at split rows 10-13. At split row 9, cut both airlines to length & install the black airline in the down pressure air bag fitting & the blue airline in the up pressure air bag fitting. At split rows 10-13, install blue airline from the up pressure air bag to the tee in the blue airline for that row & install black airline from the down pressure air bag to the tee in the black airline for that row.

Step 6: T11 & T12 Route black & blue airline from split row 15 to split row 23/24 & install the black airline into the down pressure air bag fitting & the blue airline in the up pressure air bag fitting. Trace both airlines back to split 15, installing a tee in each airline at split rows 16-22/23. At split row 15, cut both airlines to length & install the black airline in the down pressure air bag fitting & the blue airline in the up pressure air bag fitting. At split rows 16-22/23, install blue airline from the up pressure air bag to the tee in the blue airline for that row & install black airline from the down pressure air bag to the tee in the black airline for that row.

Step 7: S1 Install 2 tees in the **T1** (at rows 4 & 7) & **T5** (at rows 18 & 21) airline. Install black airline from the RD port in the 2940-103A control box to the center of the planter & install a tee. From the open port on each side of the tee, route & install black airline to the open port on each tee that was installed in the **T1** & **T5** airline (will need to use more tees). Install a tee in the middle of the **T7** (row 3 & 6) & **T11** (row 17 & 21) airline. From the open port on each tee, route & install black airline to the nearest location on the planter that the **S1** airline is. Install a tee in the **S1** to connect **T7** & **T11** airline to **S1** airline.

Step 8: S2 Install 2 tees in the **T2** (at rows 4 & 7) & **T6** (at rows 18 & 21) airline & 1 tee in the **T4** (at row 12) airline. Install blue airline from the RU port on the 2940-103A control box to the center of the planter & install a tee. From each side of the tee, install blue airline to the open port on each tee that was installed in the **T2**, **T4**, & **T6** airline (will need to use more tees). Install a tee in the middle of the **T8** (row 3 & 6), **T10** (row 12), & **T12** (row 17 & 21) airline. Route & install blue airline from the open port of each tee to the nearest location on the planter that the **S2** airline is. Install a tee in the **S2** to connect **T8**, **T10**, & **T12** airline to **S2** airline.

Step 9: S3 Install a tee in the **T3** (row 8) & **T9** (row 8) airline. Install black airline from the tee in the **T3** airline to the WT port on the 2940-103A control box. Install a tee in the **S3** airline at the nearest location to the tee in the **T9** airline & install black airline between the two tees.

Step 10 Ball Valves Install a ball valve in the black airline that connects each of the **T7** & **T11** to the **S1** airline. Install a ball valve in the blue airline that connects each of the **T8**, **T10**, & **T12** to the **S2** airline. Install a ball valve in the black airline that connects the **T9** to the **S1** airline.

32 Row Airline Diagram

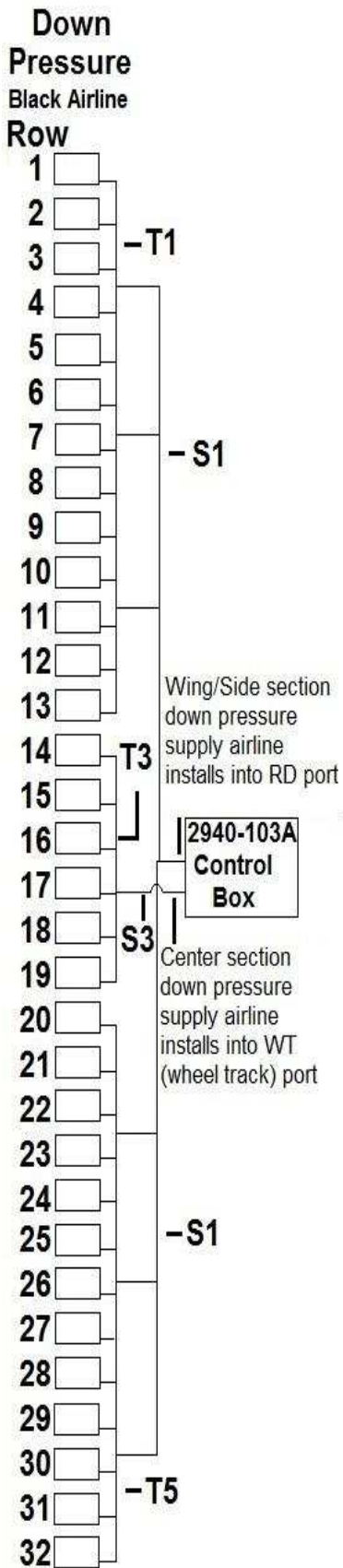

KEY

□ = Planter Row Unit

T1-6 = Trunk Line

S1-3 = Supply Line

Step 1: T1 & T2 Route blue & black airline from row 1 to row 13. At row 13, install the black airline in the down pressure air bag fitting & blue airline in the up pressure air bag fitting. Install a tee in each color of airline at rows 2-12. At each of these rows, install blue airline from the up pressure air bag to the tee in the blue airline & install black airline from the down pressure air bag to the tee in the black airline. At row 1, cut both airlines to length & install each airline into the matching air bag fitting.

Step 2: T3 & T4 Route blue and black airline from row 14 to row 19. Install each airline at row 19 into the matching air bag's fitting. Trace both airlines back to row 14 installing a tee in each airline at rows 15-18. Install blue airline from the up pressure air bag fitting to the tee in blue airline on rows 15-18. Install black airline from the down pressure air bag fitting to the tee in the black airline on rows 15-18. At row 14, cut both airlines to length and install into the matching air bag.

Step 3: T5 & T6 Route blue and black airline from row 32 to row 20. At row 20, install each airline into the matching air bag's fitting. Install a tee in each color of airline at rows 21-31. At each of these rows, install blue airline from the up pressure air bag fitting to the tee in the blue airline & black airline from the down pressure air bag fitting to the tee in the black airline. At row 32, cut both airlines to length and install each airline into the matching air bag fitting.

Step 4: S1 Cut & install a tee between rows 3/4, 6/7, & 10/11 of the T1 airline & rows 22/23, 25/26, & 29/30 of the T5 trunk airline. Route & install black airline from RD port of the 2940-103A control box to the nearest point on the main frame that the seed units are mounted to & install a tee. From each side of the tee, route black airline to the open port on each tee in the middle of the T1 & T5 trunk airline (use additional tees).

Step 5: S2 Cut & install a tee between rows 3/4, 6/7, & 10/11 of the T2 airline, row 16/17 of the T4 airline, & rows 22/23, 25/26, & 29/30 of the T6 airline. Route & install blue airline from RU port of the 2940-103A control box to the nearest point on the main frame that the seed units are mounted to & install a tee. From each side of the tee, route blue airline to the open port on each tee in the middle of the T2, T4, & T6 trunk airline (use additional tees).

Step 6: S3 Install a tee in the center of the T3 airline between rows 16/17. Route & install black airline from the WT port of the 2940-103A control box to the open port in the tee in the T3 airline.

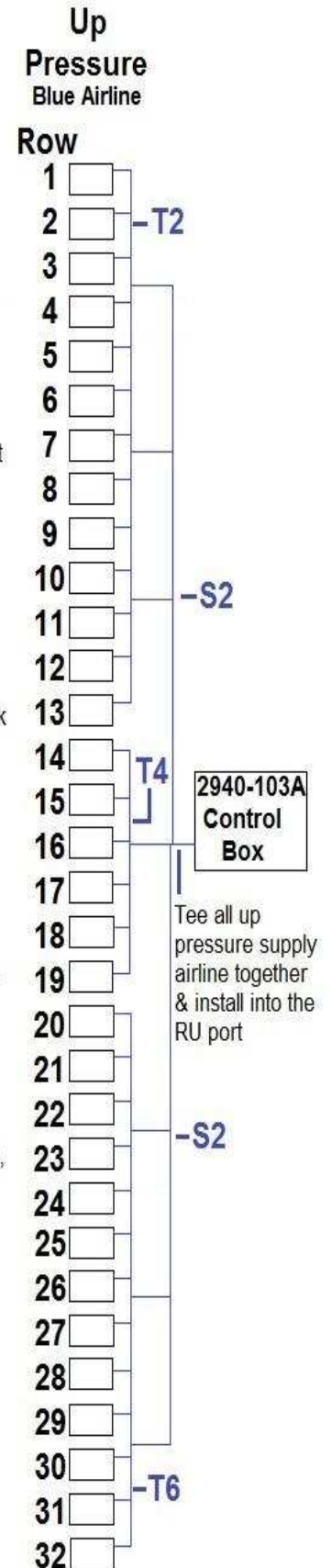

36 Row Airline Diagram

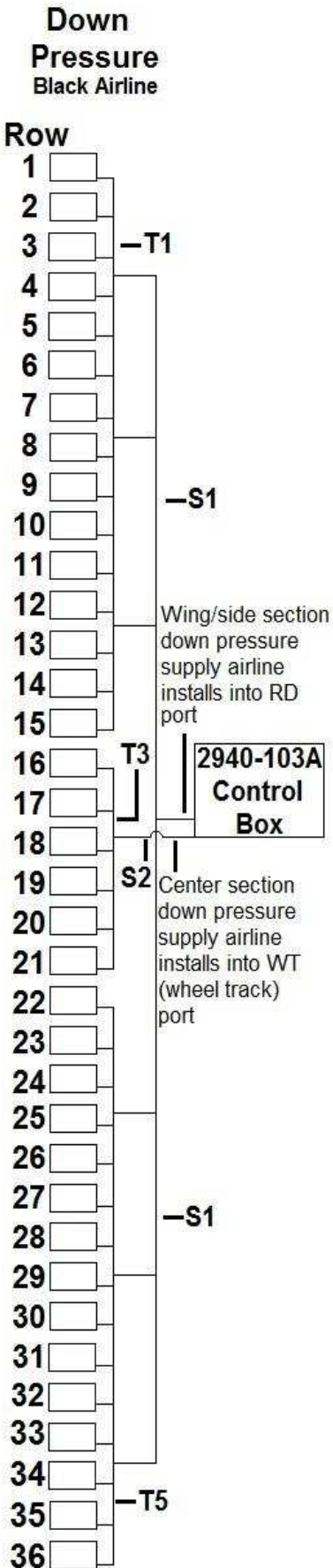

KEY

□ = Planter Row Unit

T1-6 = Trunk Line

S1-3 = Supply Line

Step 1: T1 & T2 Route blue & black airline from row 1 to row 15. At row 15, install the black airline in the down pressure air bag fitting & blue airline in the up pressure air bag fitting. Install a tee in each color of airline at rows 2-14. At each of these rows, install blue airline from the up pressure air bag to the tee in the blue airline & install black airline from the down pressure air bag to the tee in the black airline. At row 1, cut both airlines to length & install each airline into the matching air bag fitting.

Step 2: T3 & T4 Route blue and black airline from row 16 to row 21. Install each airline at row 21 into the matching air bag's fitting. Trace both airlines back to row 16 installing a tee in each airline at rows 17-20. Install blue airline from the up pressure air bag fitting to the tee in blue airline on rows 17-20. Install black airline from the down pressure air bag fitting to the tee in the black airline on rows 17-20. At row 16, cut both airlines to length and install into the matching air bag.

Step 3: T5 & T6 Route blue and black airline from row 36 to row 22. At row 22, install each airline into the matching air bag's fitting. Install a tee in each color of airline at rows 23-35. At each of these rows, install blue airline from the up pressure air bag fitting to the tee in the blue airline & black airline from the down pressure air bag fitting to the tee in the black airline. At row 36, cut both airlines to length and install each airline into the matching air bag fitting.

Step 4: S1 Cut & install a tee between rows 3/4, 7/8, & 12/13 of the T1 airline & rows 24/25, 28/29, & 33/34 of the T5 trunk airline. Route & install black airline from RD port of the 2940-103A control box to the nearest point on the main frame that the seed units are mounted to & install a tee. From each side of the tee, route black airline to the open port on each tee in the middle of the T1 & T5 trunk airline.

Step 5: S2 Cut & install a tee between rows 3/4, 7/8, & 12/13 of the T2 airline, row 18/19 of the T4 airline, & rows 24/25, 28/29, & 33/34 of the T6 airline. Route & install blue airline from RU port of the 2940-103A control box to the nearest point on the main frame that the seed units are mounted to & install a tee. From each side of the tee, route blue airline to the open port on each tee in the middle of the T2, T4, & T6 trunk airline (use additional tees).

Step 6: S3 Install a tee in the center of the T3 airline between rows 17/18. Route & install black airline from the WT port of the 2940-103A control box to the open port in the tee in the T3 airline.

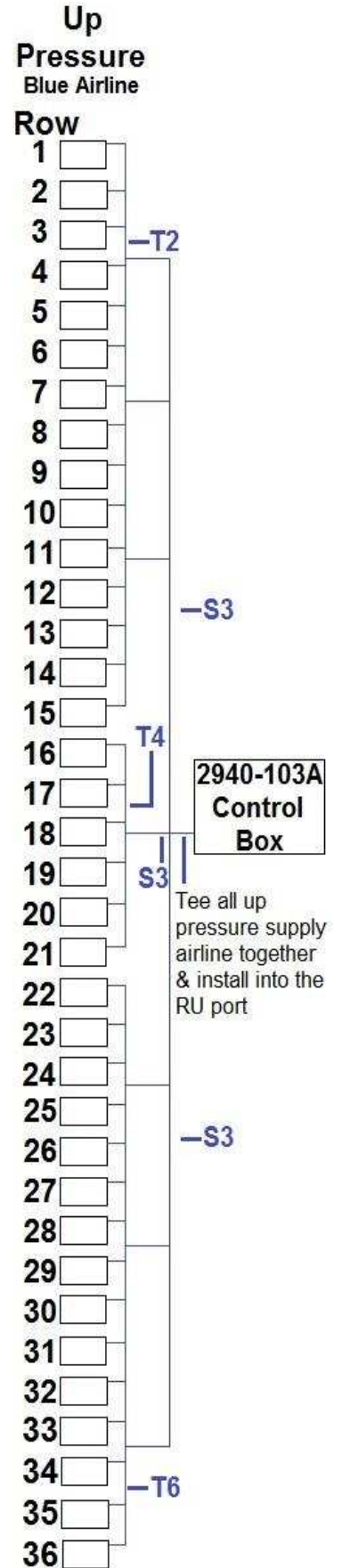

48 Row Airline Diagram

Down Pressure
Black Airline

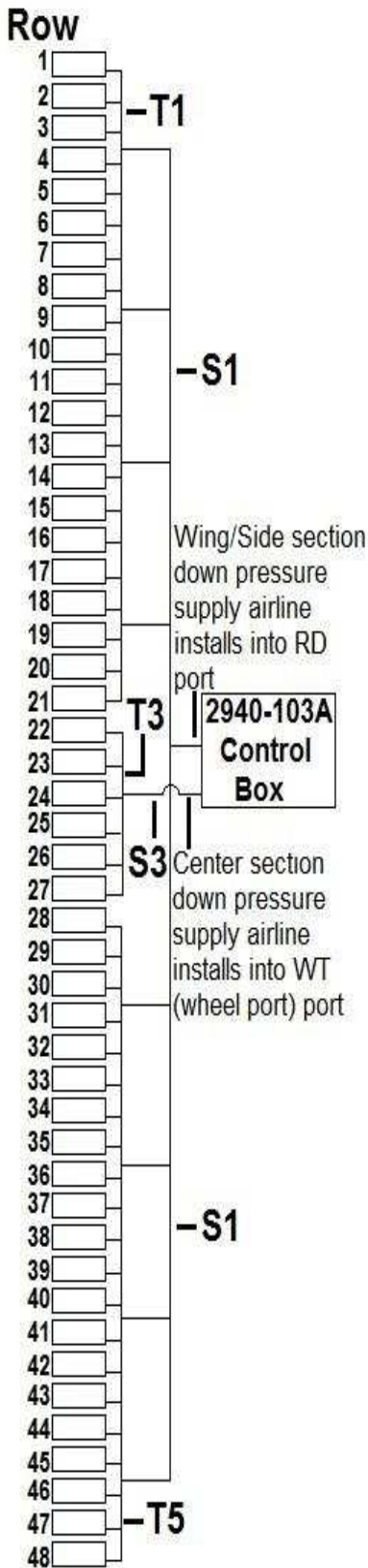

KEY

□ = Planter Row Unit

T1-6 = Trunk Line

S1-3 = Supply Line

Step 1: T1 & T2 Route blue & black airline from row 1 to row 21. At row 21, install the black airline in the down pressure air bag fitting & blue airline in the up pressure air bag fitting. Install a tee in each color of airline at rows 2-20. At each of these rows, install blue airline from the up pressure air bag to the tee in the blue airline & install black airline from the down pressure air bag to the tee in the black airline. At row 1, cut both airlines to length & install each airline into the matching air bag fitting.

Step 2: T3 & T4 Route blue and black airline from row 22 to row 27. Install each airline at row 27 into the matching air bag's fitting. Trace both airlines back to row 22 installing a tee in each airline at rows 23-26. Install blue airline from the up pressure air bag fitting to the tee in blue airline on rows 23-26. Install black airline from the down pressure air bag fitting to the tee in the black airline on rows 23-26. At row 22, cut both airlines to length and install into the matching air bag.

Step 3: T5 & T6 Route blue and black airline from row 48 to row 28. At row 28, install each airline into the matching air bag's fitting. Install a tee in each color of airline at rows 29-47. At each of these rows, install blue airline from the up pressure air bag fitting to the tee in the blue airline & black airline from the down pressure air bag fitting to the tee in the black airline. At row 48, cut both airlines to length and install each airline into the matching air bag fitting.

Step 4: S1 Cut & install a tee between rows 3/4, 8/9, 13/14, & 18/19 of the T1 airline & rows 30/31, 35/36, 40/41, & 45/46 of the T5 trunk airline. Route & install black airline from RD port of the 2940-103A control box to the nearest point on the main frame that the seed units are mounted to & install a tee. From each side of the tee, route black airline to the open port on each tee in the middle of the T1 & T5 trunk airline (use additional tees).

Step 5: S2 Cut & install a tee between rows 3/4, 8/9, 13/14, & 18/19 of the T2 airline, row 23/24 of the T4 airline, & rows 30/31, 35/36, 40/41, & 45/46 of the T6 airline. Route & install blue airline from RU port of the 2940-103A control box to the nearest point on the main frame that the seed units are mounted to & install a tee. From each side of the tee, route blue airline to the open port on each tee in the middle of the T2, T4, & T6 trunk airline (use additional tees).

Step 6: S3 Install a tee in the center of the T3 airline between rows 23/24. Route & install black airline from the WT port of the 2940-103A control box to the open port in the tee in the T3 airline.

Up Pressure
Blue Airline

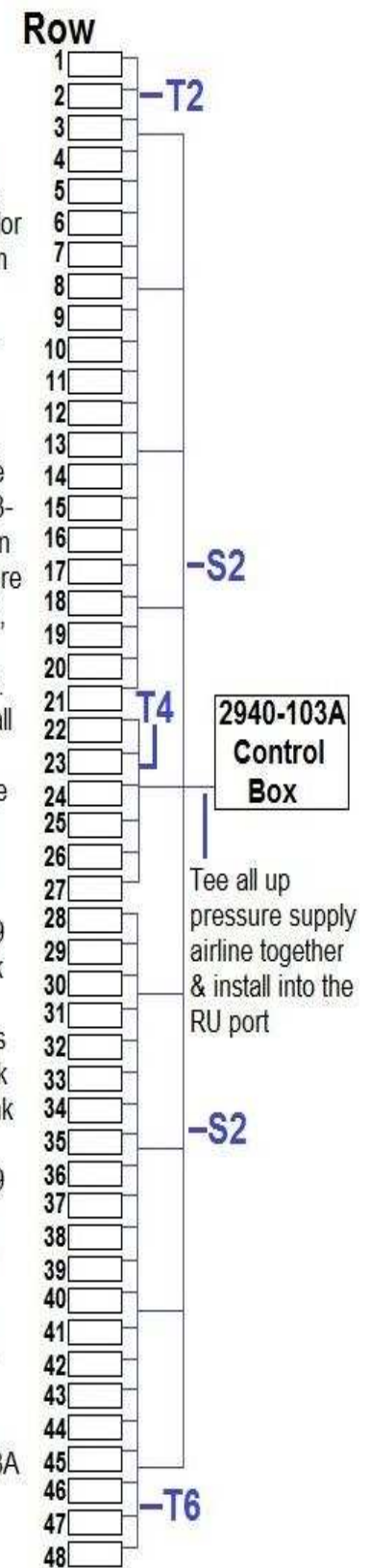

54 Row Airline Diagram

Down
Pressure
Black Airline
Row

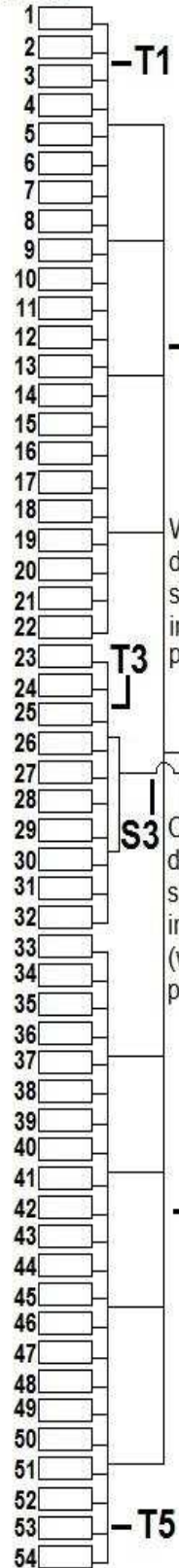

KEY

☐ = Planter Row Unit

T1-6 = Trunk Line

S1-3 = Supply Line

Step 1: T1 & T2 Route blue & black airline from row 1 to row 22. At row 22, install the black airline in the down pressure air bag fitting & blue airline in the up pressure air bag fitting. Install a tee in each color of airline at rows 2-21. At each of these rows, install blue airline from the up pressure air bag to the tee in the blue airline & install black airline from the down pressure air bag to the tee in the black airline. At row 1, cut both airlines to length & install each airline into the matching air bag fitting.

Step 2: T3 & T4 Route blue and black airline from row 23 to row 32. Install each airline at row 32 into the matching air bag's fitting. Trace both airlines back to row 23 installing a tee in each airline at rows 24-31. Install blue airline from the up pressure air bag fitting to the tee in blue airline on rows 24-31. Install black airline from the down pressure air bag fitting to the tee in the black airline on rows 24-31. At row 23, cut both airlines to length and install into the matching air bag.

Step 3: T5 & T6 Route blue and black airline from row 54 to row 33. At row 33, install each airline into the matching air bag's fitting. Install a tee in each color of airline at rows 34-53. At each of these rows, install blue airline from the up pressure air bag fitting to the tee in the blue airline & black airline from the down pressure air bag fitting to the tee in the black airline. At row 54, cut both airlines to length and install each airline into the matching air bag fitting.

Step 4: S1 Cut & install a tee between rows 4/5, 8/9, 13/14, & 18/19 of the T1 airline & rows 36/37, 40/41, 45/46, & 50/51 of the T5 trunk airline. Route & install black airline from RD port of the 2940-103A control box to the nearest point on the main frame that the seed units are mounted to & install a tee. From each side of the tee, route black airline to the open port on each tee in the middle of the T1 & T5 trunk airline (use additional tees).

Step 5: S2 Cut & install a tee between rows 4/5, 8/9, 13/14, & 18/19 of the T2 airline, row 25/26 & 29/30 of the T4 airline, & rows 36/37, 40/41, 45/46, & 50/51 of the T6 airline. Route & install blue airline from RU port of the 2940-103A control box to the nearest point on the main frame that the seed units are mounted to & install a tee. From each side of the tee, route blue airline to the open port on each tee in the middle of the T2, T4, & T6 trunk airline (use additional tees).

Step 6: S3 Install a tee in the center of the T3 airline between rows 25/26 & 29/30. Route & install black airline from the WT port of the 2940-103A control box to the open port in these tees in the T3 airline.

Up
Pressure
Blue Airline
Row

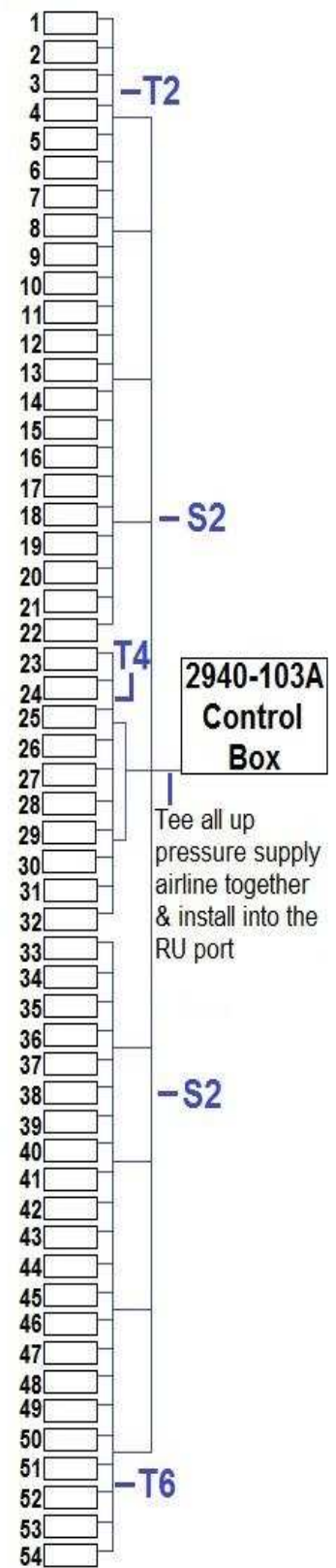

Downloading the Yetter App (Tablet Operation Only)

- STEP 1:** Go to your tablets app store, search Yetter Air Adjust & download the Yetter app.
- STEP 2:** Go to WiFi settings once Thrasher module has 2 lights flashing, connect to AirAdjust(XXXX), The last 4 #'s will be last 4 of modules serial # **PASSWORD IS: 12345678**
- STEP 3:** Put the Yetter icon on your tablet in a spot that is easy to get to, & then open Yetter app.
- *ANYTIME POWER IS RESTORED TO THE 2940-653 THRASHER MODULE, GO INTO SETTINGS TO CONNECT BACK TO "AIR ADJUST" WiFi TO CONNECT TO THE YETTER SYSTEM.***

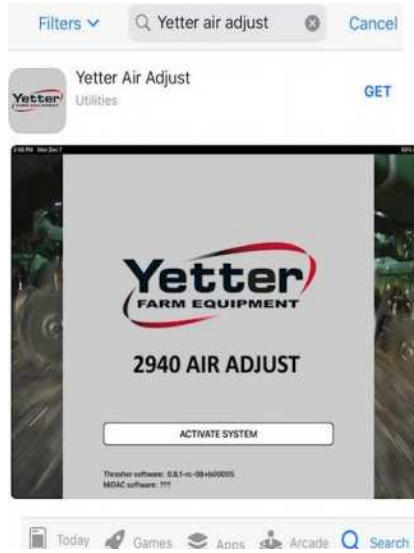

 SMART PHONES ARE NOT COMPATIBLE WITH THE YETTER SYSTEM AT THIS TIME

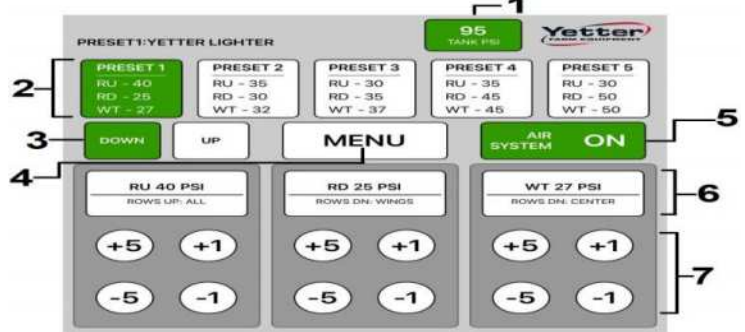
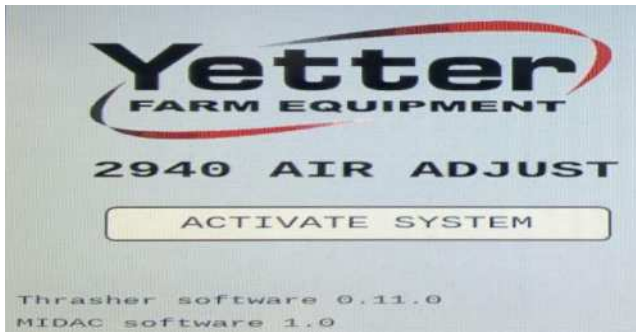

Cab Controller Operation – Tablet & ISOBUS



ACTIVATION SCREEN – Press the ACTIVATE SYSTEM icon to engage the system & get to the operation screen.

- 1. SYSTEM PRESSURE/COMPRESSOR MONITORING** Just to the left of the Yetter logo, you can monitor system pressure. If the system is below 75psi upon initial startup or below 50psi for more than 5 seconds during operation, the rectangle will turn red & system will not allow air to the row cleaner air bags. If the rectangle is green, the system pressure is good & operator is in full control of the system. The tank psi reading is taken down-stream of the water separator/regulator assembly & won't represent actual tank pressure. Actual tank pressure should be 125-145psi.
- 2. PRESETS 1 – 5:** 5 Presets allow for quick changes on the go for changing field conditions or can be used as starting points for starting a new field. Presets can be edited in the Menu section where you can change the name of the preset or the psi that the preset is currently saved as. The preset that is being used will be highlighted in **GREEN** & the name of the preset will be shown. If the operator has made a manual adjustment from the saved Preset, an asterisk (*) will display in front of the name of the preset.
- 3. DOWN** – Press this icon to raise row cleaners all the way up. The icon will change to this  when in the UP position.
Pressing the  icon will lower the row cleaner back to operating position / target pressures.
- 4. MENU**- Press to display Menu Options. If in Menu Options, pressing **BACK** will take the operator back one screen & pressing **EXIT** will take you back to the main operating page shown above. See [page 49](#) for MENU screen navigation.
- 5. AIR SYSTEM ON** – Displays the state of the system. Press this icon to deactivate the system. (THIS SHOULD BE PRESSED BEFORE SHUTTING THE TRACTOR OFF)
- 6. RU, RD, & WT** – These give you the target pressures for each circuit. The name of each circuit can be renamed. For example, if on a split row planter, you plumb the back rank down pressure separate from the front rank down pressure, you can rename the **RD** circuit FRONT ROWS DOWN & the **WT** circuit BACK ROWS DOWN. Touch the name to edit.
- 7. MANUAL PRESSURE CHANGE:** Each circuit is edited individually by +/-1psi or +/-5psi increments.

AIR SYSTEM FILLING – If the compressor supplying air to the Yetter 2940 system has less than 75psi, the Yetter 2940 system will not supply air to the air bags of the row cleaners. If the system is above 75psi & then drops below 75psi for 5 seconds, the Yetter 2940 system will return to the **AIR SYSTEM FILLING** state. A leak check needs performed.

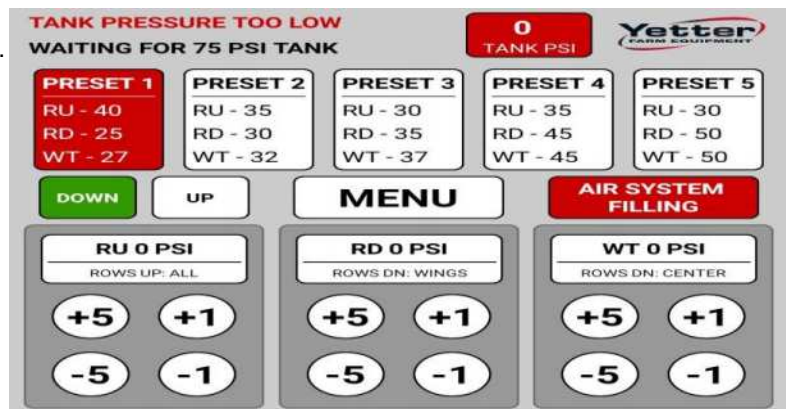

2940 Air Adjust Operation

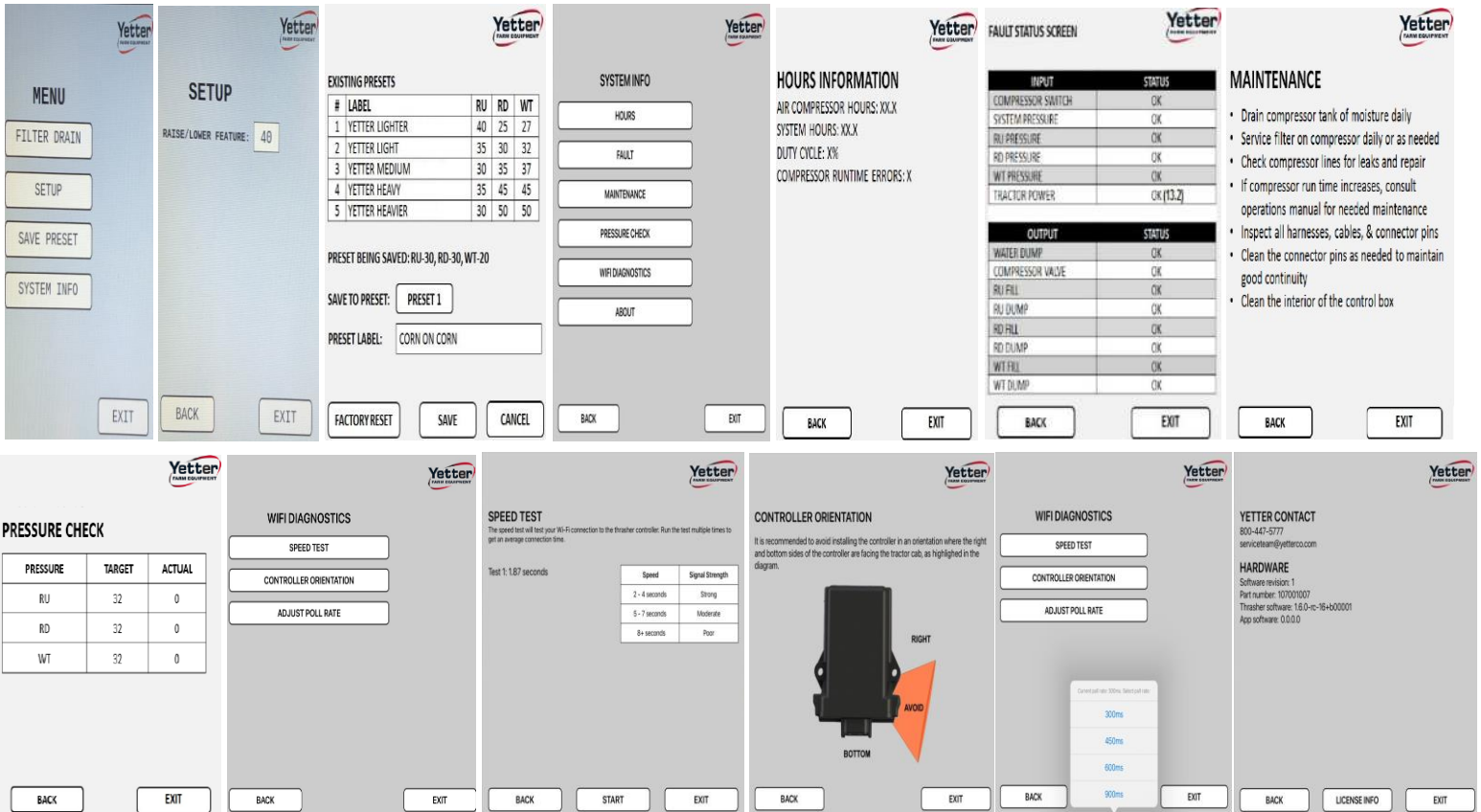

Screen Control and Navigation:

SCREEN NAVIGATION: The **MENU** icon will take you away from operation screen. Pressing **EXIT** will take you to operation screen. Pressing **BACK** will take you to the previous screen.

FILTER DRAIN: Pressing this icon will drain the water separator valve for 5 seconds. The water separate valve will cycle for 7 seconds every time the system in powered on.

SETUP: Pressing this icon will take you to a screen where you can edit the amount of up pressure to raise the row cleaner. From the factory, this is preset at 40psi. Touch 40 to edit, will save automatically on tablet application, press OK on ISOBUS application. The minimum you can set this is 25psi, the maximum is 100psi. If you have air bags, DO NOT set above 60psi.

SAVE PRESET: The system will have 5 factory presets stored & named. Preset 1 being the lightest & 5 being the heavier/more aggressive. If the operator adjusts the pressures away from a preset & wants to save these new target pressures as a preset, press MENU, then SAVE PRESET, select which preset you want to save these new target pressures on (1 – 5), rename the preset if desired, & press SAVE. Pressing FACTORY RESET will change all presets back to factory settings.

SYSTEM INFO: On the system info screen, the operator can select 5 different icons, or press BACK to go back to the MENU screen or EXIT to go back to the operation screen.

HOURS: Air compressor hours is the amount of time the compressor has ran (or was supposed to be running), System Hours is the amount of time the air adjust system has been activated, Duty Cycle is the percentage of time the compressor has been engaged in accordance with system hours, (i.e. if compressor hours 5 & system hours is 50, duty cycle is 10%), & Compressor Runtime Errors is the amount of times the compressor has ran for 15 continuous minutes.

FAULT STATUS: This screen displays the status of the system. Anytime a CHECK FAULT STATUS message pops up in the top left corner of the operation screen, navigate to this page to determine what may be the problem.

MAINTENANCE: This page will display some details that should be regularly practiced to prolong the life of the Air Adjust system.

PRESSURE CHECK: This page allows the operator to make sure his target pressures & the actual pressures are in tolerance. The tolerance specs are +/- 7psi of the target pressure. If target is 30, actual is 35, that is within tolerance.

WiFi DIAGNOSTIC:

SPEED TEST – Allows you to check the communication speed between tablet & Thrasher

CONTROLLER ORIENTATION – Shows operator what side of Thrasher provides strongest signal that should face tablet

ADJUST POLL RATE – Allows you to slow speed that messages are sent between Tablet & Thrasher if having WiFi issues

ABOUT: This is info about the system & contact info for Yetter if any questions or service issues come up.

2940 Air Adjust Operation

Error Messages



NO BATTERY POWER: If the 40A Breaker trips or a battery power cable becomes disconnected or damaged & insufficient power is delivered to the Yetter 2940-103A, this message will appear. Inspect the breaker/power cables & repair.

NO CONNECTION TO THRASHER: If the 2940-653 Thrasher module is not connected to ISOBUS or Tablet controller, this message will appear. Check the lights on the Thrasher module (mounted to exterior of the control box), if using a Tablet, the operating status & status 1 lights will illuminate. Make sure the tablet is connected to the WiFi signal named AIRADJUST####. If using ISOBUS, the status 2 light will also illuminate. Turn switched power off to the 2940-103A, & then back on to reconnect to WiFi if problem persists. Deleting & reuploading Yetter App may need done.

HIGH COMPRESSOR RUN TIME: If using a Yetter compressor, the system has a time limit that the compressor can run before timing out. If the compressor runs for 15 minutes without turning off via the pressure switch, this message will appear. Perform a leak check on the system. On hydraulic compressors, this message will appear while in transport when no hydraulic flow is being sent to the hydraulic motor on the compressor.

NO CONNECTION BETWEEN THRASHER & MIDAC: If there is no communication between the 2940-112A Midac control module inside the 2940-103A control box & 2940-653 Thrasher module on the outside of the control box, this message will appear. Check the connections/harness between the 2 modules to make sure nothing became disconnected/damaged.

Operation Settings:

“How much Down/Lift Pressure should I be running?”

The amount of Down/Lift Pressure will vary greatly across soil types, tillage practices, soil moisture, row unit weight & many other variables. Manage the pressure in the down &/or lift circuits in order to maintain 90%+ ground contact while keeping the pressure between 10-60 psi. The cab controller will display the tank pressure in psi, if the compressor is engaged, a lightning bolt will appear, & the down/lift circuits in psi. A typical starting range for residue managers (RM) would be 35psi up, 30psi down, and 32psi WT. A typical starting range for RM/ combo would be 30psi up, 35 psi down, 37psi WT. When an ideal pressure setting is found for a certain field condition & the operator wants to save it as a preset, press MENU, press SAVE PRESET, select the preset you want to save over, rename the preset if desired, & press SAVE. If the residue managers aren't removing enough residue, add more down pressure or subtract some up pressure. If the residue managers are being too aggressive, subtract down pressure or add up pressure.

Normal operating ranges:

- Down Pressure Bags: 10-60psi
- Lift Pressure Bags: 10-60psi
- Tank Pressure: The gauge at the tank will read 145psi when full. The tank pressure reading on the cab controller will be around 100-120psi, depending with the regulator on the water separator assembly is set at. The tank has a safety relief valve that will automatically exhaust excess pressure in the event that the pressure would exceed 175 psi.

2940 Operation Guide

System Start Up Procedure

Below is the 2940 system startup procedure that should be followed every time the 2940 system is turned on. This will ensure that component parts of the system are working correctly. If this is the first start up procedure after installation, make sure to familiarize yourself with cab controller operation first.

Step 1: Supply switched power to control box (start the tractor or turn the key forward if just testing the system with shop air)

Step 2: If using Tablet, connect to Air Adjust WiFi & open Yetter App. Press ACTIVATE SYSTEM. If using ISOBUS, open Yetter run page & press ACTIVATE SYSTEM.

Step 3: If using Yetter compressor, the compressor should engage (apply hydraulic flow if applicable) to build 145psi & shut off. If 145psi isn't reached, **see page 53** to make an adjustment to the flow control valve. If Yetter compressor doesn't run & is below 125psi, check the 40A breaker (& 80A breaker on Yetter electric compressor applications) on tractor battery. Trip breaker & reset breaker arm firmly back into pocket. If using other OEM compressor, engage compressor & allow compressor to run a complete cycle & shut off. If using shop air, unplug onboard compressor's solenoid & make sure system pressure is at least 100psi.

Step 4: When compressor has shut off, press a preset (1 – 5) to apply air to the air bags of the residue managers. Make sure the TANK PSI holds steady. If tank pressure drops & will not hold, turn all pressures (RU, RD, & WT) to 0psi & perform leak check (**see page 54**). Once the tank pressure holds, proceed to the next step.

Step 5: Press the UP icon on the screen while watching all the residue managers. When this button is pressed, the residue managers should all raise as up pressure is now at 40psi & both down pressure circuits exhaust to 0psi.

Step 6: Press the DOWN icon while watching all the residue managers. When this button is pressed, the residue managers should all lower back to operating position as all 3 circuits go back to commanded target pressures.

ROW CLEANER DO'S AND DON'TS

1. **DO NOT** use as a tillage tool; Residue Managers are designed to move crop residue & to break up clods & crust.
2. **DO NOT** operate planter at slow speeds. Ground speed affects how aggressive the residue manager wheels are. Operate at sufficient speed (refer to you OEM planter manufacturer manual) to maintain good residue flow.
3. **DO NOT** expect 100% of crop residue to be cleared, it is not necessary and would necessitate engaging the soil. The width of path cleared depends on ground conditions, depth setting, and ground speed.
4. **DO** expect to see wheels occasionally quit turning, indicating ideal (shallow) setting which is not moving soil.
5. **DO** adjust toolbar frame height 20"-22" and drawbar correctly. It is very important to ensure planter opener will follow ground contours properly. **See Page 52 for the planter levelness and height.**
6. **DO NOT** run air pressure below 10psi or above 60psi. Full range of travel can be achieved between these settings.
7. **DO NOT** run the coulter, if equipped, deeper than the disc opener blades. Coulter should be set to run even or slightly above disc opening blades depth.

IMPORTANT: For proper operation, the planter frame must operate level (fore, aft and side to side) and at the correct height, typically 20"-22". Regularly inspect the residue managers for loose or worn bolts & hardware. Repair or replace as needed.



Overview:

This electronic control system works with a pneumatic system that controls pressure in the air bags on an agricultural application. The air bags provide independent up **AND** down pressure to the mechanical devices that are used on an agricultural implement.

System Layout:

There are (3) main parts to the control system. First, a VDM (Valve Drive Module) is to provide Outputs to control functions of the pneumatic system. The VDM will also provide Inputs to monitor the pneumatic system as well as provide feedback to the operator. The second part is an in-cab display (Tablet or ISOBUS VT) that allows the operator to control the pneumatic system and monitor its performance. Thirdly, the pneumatic system sends air to each circuit as commanded from the operator.

OPERATION PRECAUTIONS



STOP

MACHINE OPERATION

Read this before field operation of the Yetter product.

IMPORTANT: Failure to properly set the planter frame height & levelness can result in less than successful operation of the planter & the Yetter product. This may result in **damaged equipment**. All operators should read & thoroughly understand the instructions given prior to using the Yetter product.

NOTE: DO NOT use this product if the planter is not adjusted properly!

Leveling the planter: On a level planting surface, lower the planter frame to an operation height of **20"-22"**. Make adjustments to the planter as necessary. Read the planter operator's manual for recommended setting. Check to be sure the toolbar & row unit parallel arms are level fore & aft. Re-Check when the planter is in the field & has been fully loaded with seed, fertilizer, etc. Also, a field check with a bubble level on the frame should be made of the hitch height to ensure level operation front to back. It is important for the planter to operate level laterally. Tire pressure must be maintained at pressures specified by the manufacturer. Field & actual planting conditions change & will dictate planter frame heights. You must ensure that the row unit parallel arms are approximately parallel with the ground.

IMPORTANT: For proper operation of the planter attachments & row units, it is imperative that the planter toolbars and row unit parallel arms be level side-to-side & front-to-rear. The toolbar frame should operate at a 20"-22" height from the planting surface. Check the manufacturer's operator's manual for instructions on how to adjust the frame height & levelness.

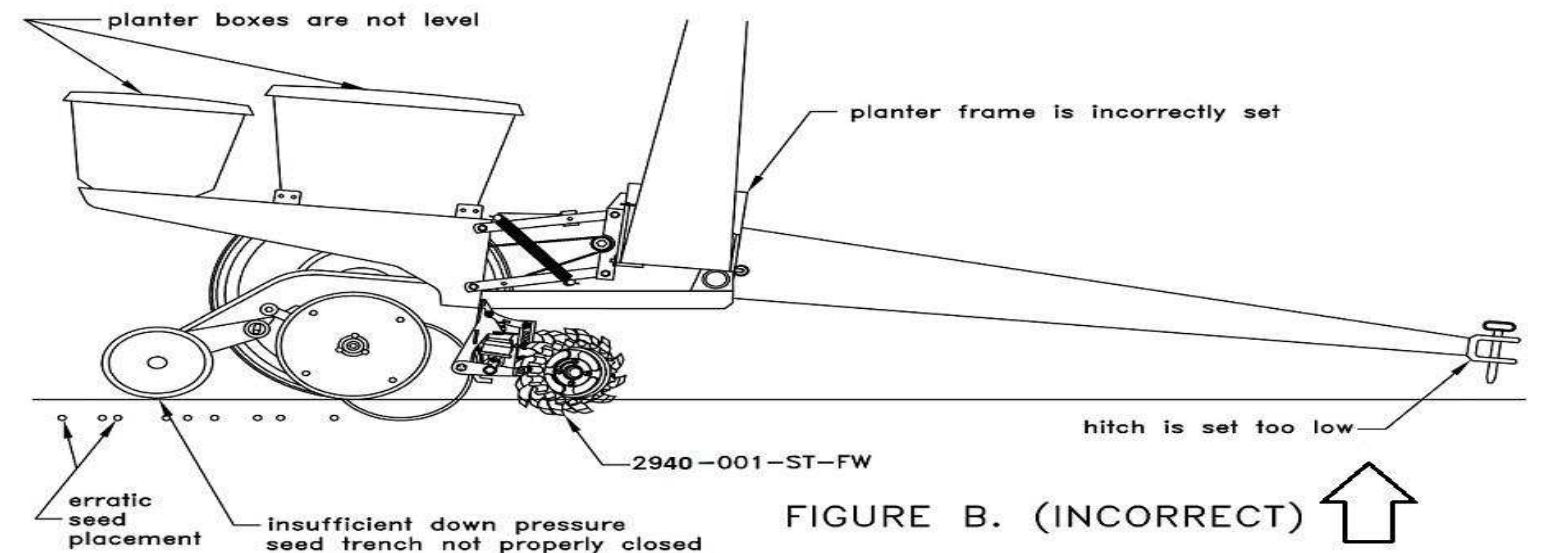
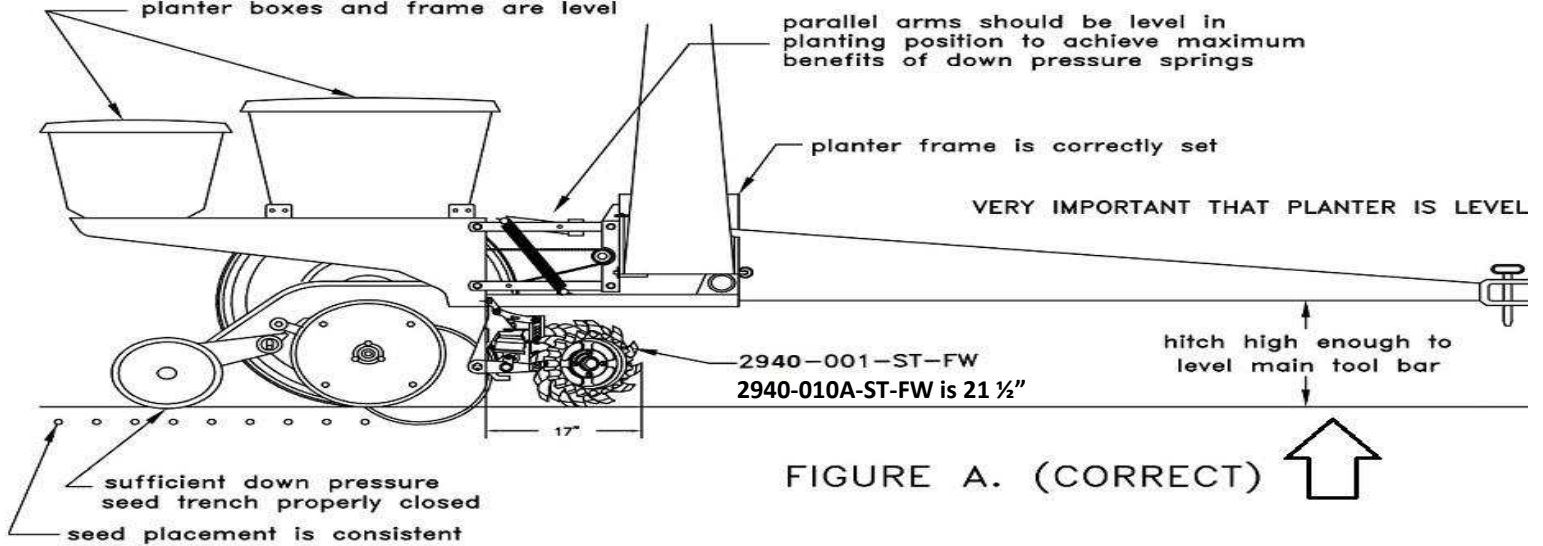

OPERATION PRECAUTIONS

To ensure the hydraulic compressor motor doesn't exceed recommended operating RPM level, the hydraulic oil flow control valve has been preset. In some instances, the compressor may run below optimum rpm, or will not reach 145psi of tank pressure read at the gauge on the compressor tank causing the VDM to think the compressor is running continuously. (High Compressor Run Time message will appear on cab controller) If this is the case, an adjustment to the flow control valve needs made. Only open the flow control valve enough to allow compressor to build to 145psi tank pressure read at the gauge on compressor tank. Opening the flow control too far could cause over speeding and reduced service life of the compressor. The liquid filled gauge on the hydraulic block will read the amount of hydraulic pressure (should be 2500-3000psi) Follow the instructions below to make the proper adjustment.

NOTE: Before making any adjustments to the flow control valve, adjust the tractor hydraulic flow fully open. Adjusting the tractor's hydraulic flow will affect the compressor's RPM. The hydraulic motor speed on the hydraulic compressor should not exceed 1350RPM. RPM's on the hydraulic compressor may be checked via the fan blades with an optical tachometer.

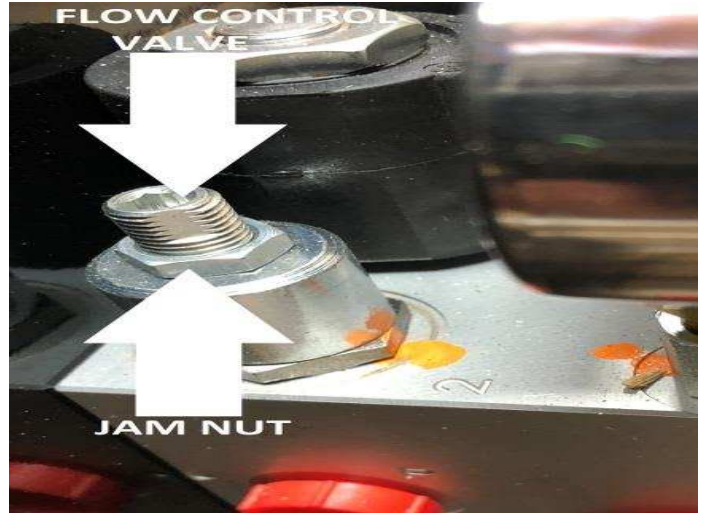
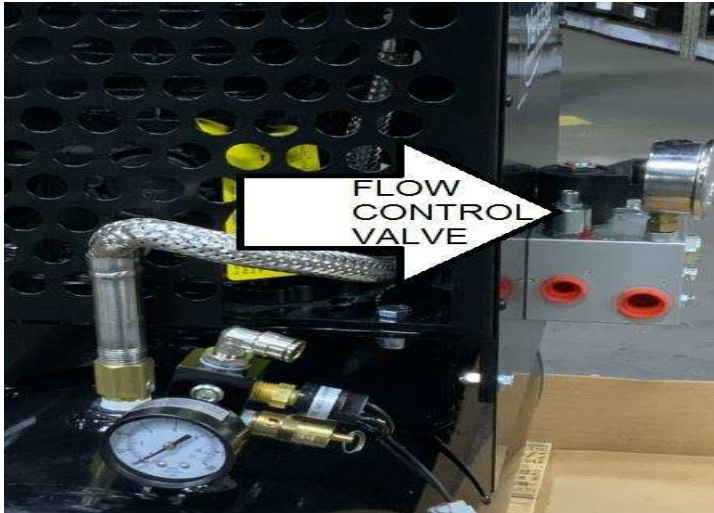

- STEP 1:** Engage the hydraulics to the compressor and press ACTIVATE SYSTEM icon.
- STEP 2:** Make adjustments while hydraulic motor is running or should be running. Open the tank drain to engage compressor if necessary.
- STEP 3:** Insert a 3/16 Allen wrench into flow control valve. Loosen jam nut by turning ½ wrench counterclockwise.
- STEP 4:** Using the Allen wrench, **SLIGHTLY** turn the flow control valve counterclockwise (the equivalent to 3 degrees or 1/32 of a turn) to increase the hydraulic motor speed.
- STEP 5:** Hold the Allen wrench in place and tighten the jam nut. Each time an adjustment is made, allow the compressor to build to its potential 145psi shut off mark. If 145psi is not achieved, drain tank pressure until compressor turns on, and make another adjustment. Repeat these steps until 145psi is achieved so that the compressor runs smoothly without struggle. **DO NOT RUN MOTOR ON COMPRESSOR MORE THAN 1350RPM!** RPMs can be checked with an optical tachometer using the fan blades. Once the flow control valve is set properly, hold the Allen wrench in place and tighten the jam nut.

Pre-Field Operation Guide

LEAK TESTING:

A leak testing procedure should be performed after set-up of the 2940 Air Adjust system is complete. This procedure shall be performed at the beginning of each planting season and every 20 hours of in season use. **In addition, it should be performed if the user notices a lack of air pressure availability or if the compressor is running an abnormally high duty cycle or run time.** It will help keep the duty cycle in check, thus extending the life of the compressor. The most efficient way to perform a leak test is to use shop air, if available, to allow for a quieter environment to detect an air leak better. A 2940-382 shop air adaptor is provided in the 2940-174 spare fittings bag. The shop air adaptor is equipped with a shut off valve. Attach your matching male coupler to the open ¼"NPT & install airline between the 3/8PTC fitting & the water separator inlet port. Wrap the male threads of the shop air fitting with Teflon tape.



Pre-Field Operation Guide Con't

SYSTEM LEAK TESTING:

- Step 1:** Power the Yetter control box, connect tablet to “AirAdjust#####” WiFi & open Yetter app or if ISOUBS application, open Yetter run page on the ISOBUS VT, & press ACTIVATE SYSTEM. If using planters onboard compressor, make sure the compressor has run 1 complete cycle, and shut off to make sure there are no leaks at compressor & control box.
- Step 2:** With 0psi commanded to the RU, RD, & WT circuits, note the pressure on the compressor tank gauge. Start a stop watch & after 5 minutes, note the tank pressure. If tank pressure drops more the 5 psi, check for leaks around/inside the compressor housing, water separator, & control box. Repair as needed.
- Step 3:** Turn the lift pressure (RU) to 40psi, exit the tractor cab, & start at the compressor housing checking all blue airline on the RU circuit for air leaks. The row cleaners should be in the raised position. Check all fittings, tees, & airline on the RU circuit. Repair leaks as needed, return to the cab, & turn the lift pressure back to 0psi.
- Step 4:** Turn the down pressure (RD) & wheel track (WT) pressure to 40psi, exit the tractor cab, & start at the compressor housing checking all black airlines on the RD & WT circuit for leaks. The row cleaners should be firmly in the down position. Check all fittings, tees, & airline on the RD & WT circuits for air leaks. Repair leaks as need, return to the tractor cab, & turn all circuit pressures to 0psi.
- Step 5:** With 40psi commanded in the RU, RD, & WT circuits, note the pressure on the compressor tank gauge. Start a stop watch & after 5 minutes, note the tank pressure on gauge at the tank. If tank pressure drops more than 10psi, check for leaks on the row cleaner fittings, tees, and dump valves. Repair as needed.

AIR COMPRESSOR PRE-OPERATING TEST PROCEDURE:

Before beginning this test, run the compressor system leak test and ensure it passes. There should be virtually no leaks in the tank circuit before performing this test. Use a stop watch to time the hydraulic compressor’s recovery time. Start time when tank gauge reaches 125psi & the compressor turns on. Stop the time when compressor shuts off at 145psi. If the time is greater than 20 seconds, there is a potential leak, the compressor is worn, or compressor’s RPMs are too slow. Repair as needed.

Proper Settings

Air Pressure Settings

Residue Managers Only

A common question is “What pressures should I start out at?” A good starting pressure setting would be PRESET 2: 35psi Up Pressure (RU), 30psi Down Pressure (RD), & 32psi Wheel Track (WT). This particular setting will give each row cleaner a nice, sturdy float. If this pressure setting doesn’t remove enough residue or trenches/digs furrows, adjust the settings accordingly until the row cleaner is doing exactly what you want it to do. If the row cleaner is trenching, move to a lighter preset, in this case, PRESET 1. If not enough residue is removed, move to a heavier preset, in this case, PRESET 3 – 5. Once a preset is found or is very close, fine tune the preset using the +/-1 icons. Each field may require a different setting even though field conditions seem the same. For example, if you use a setting for one no-till field planting corn in soybean residue, you may find that the setting used for the next field planting corn in soybean residue in no-till conditions may be different. The reason may be the amount of residue, soil types, moisture amounts, etc.

Residue managers/Coulter Combos

A common question is “What pressures should I start out at?” A good starting pressure setting would be PRESET 3: 30psi Up Pressure (RU), 35psi Down Pressure (RD), & 37psi Wheel Track (WT). This particular setting will give each row cleaner a nice sturdy float. If this pressure setting doesn’t remove enough residue or trenches/digs furrows, adjust the settings accordingly until the row cleaner is doing exactly what you want it to do. If the row cleaner is trenching, move to a lighter preset, in this case, PRESET 1. If not enough residue is removed, move to a heavier preset, in this case, PRESET 3 – 5. Once a preset is found or is very close, fine tune the preset using the +/-1 icons. Each field may require a different setting even though field conditions seem the same. For example, if you use a setting for one no-till field planting corn in soybean residue, you may find that the setting used for the next field planting corn in soybean residue in no-till conditions may be different. The reason may be the amount of residue, soil types, moisture amounts, etc.

Renaming Presets

Presets can be edited 2 ways: target pressure & preset label. To help the operator better understand which preset to start out with, renaming the preset label to the planting condition is a good idea. Preset names have a 20 character max limit. If planting corn into corn stalks, a good name for the preset might be CORN ON CORN. If planting into a variety of tillage conditions, naming your presets for each condition might be best: NO TILL, STRIP TILL, CONVENTIONAL TILL, etc. Use the renaming of the presets to allow all operators to have a better understanding of the best starting point for the row cleaner pressures when entering a new field. 1 field that is no-till with soybean stubble may use different pressures than another field of no-till soybean stubble. Use +/-1 icon in each circuit to fine-tune the row cleaners to perform exactly how the operator wants them to. Make sure to press **SAVE** after all edits if wanting to keep.

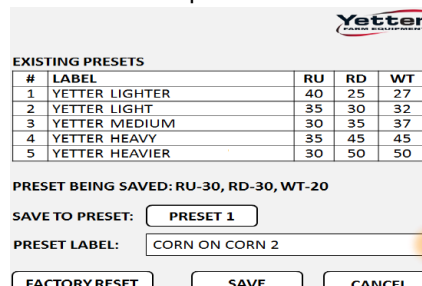
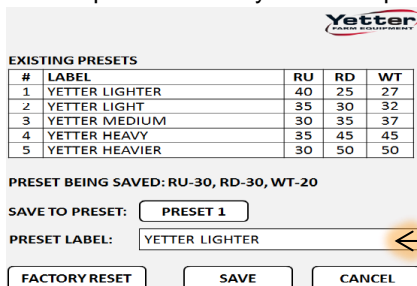

Yetter Hydraulic Compressor Maintenance

WARNING:

 Keep extremities out of the compressor housing when compressor is running, has potential to run, or recently shut off as there are rotating and high temperature parts that may cause injury. Always turn tractor off & disconnect power before performing any maintenance.

LUBRICATION:

The compressor is shipped empty of pump lubrication and needs oil added before operation. Provided is a 1 Liter bottle of grade 111 full synthetic. Add oil until oil level is seen half way up on the sight glass & then recheck oil level on the dipstick. Yetter part number for purchasing new bottle is 2940-550. Full synthetic oil in the hyd. comp. pump should always be used.

GUARDS:

Always ensure the housing and guards are in place during operation.

AIR FILTER CARTRIDGE:

Yetter part number 2940-549. Order as needed.

MAINTENANCE SCHEDULE GUIDE

DAILY

- Check oil level and fill as needed
- Check air filter cleanliness and clean/replace as needed
- Check hoses for fluid leaks and replace/fix as needed
- Check air lines for air leaks and replace/fix as needed
- Check component parts of the compressor for damage (pressure switch, cooling fan, gauge, etc)
- Open Tank Drain Valve (10 seconds) **(see illustration to the right)** to allow moisture to drain----->

SEASONALLY/200 COMPRESSOR HOURS

- Change compressor oil
- Change inlet air filter
- Check fluid hoses and air lines for weakness or weathering and replace as needed.
- Check hydraulic fittings for proper connections with no leaks, replace as needed.

Closed



Open



 **FIRST OIL CHANGE SHOULD TAKE PLACE AFTER APPROXIMATELY 50 RUNNING HOURS**

CLEANING OR REPLACING THE 2940-106 AIR FILTER



Filter cleanliness is critical to maintain the performance & service life of the compressor. Recommendations for cleaning are DAILY & replace every 200 hours OR at beginning of every planting season. Dirt sucked passed the filter will ruin the pump.

STEP 1: Remove the wing nut, filter cover & filter. (If cleaning, tap the filter on a solid surface to remove dirt from the pleats & clean the filter base. **DO NOT USE COMPRESSED AIR TO CLEAN FILTER!**)

STEP 2: Install new or cleaned filter, cover, & wing nut removed in step 1. **TIGHTEN WING NUT SECURELY.**

REPLACING THE COOLING FAN

Remove the housing & hydraulic motor, loosen the LH bolt on the end of the shaft, use a pry bar to apply pressure to the back side of the fan while tapping on the LH bolt head until fan coupler is loose on the pump shaft, replace fan, tighten LH bolt, reinstall, the hydraulic motor & put the housing back on.

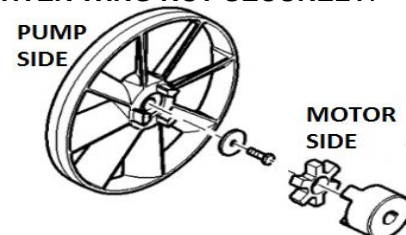

Yetter Hydraulic Compressor Maintenance

Check Hydraulic Air Compressor Oil

⚠ Deactivate SCV operating hydraulic compressor and turn tractor off before servicing

NOTE: Check hydraulic air compressor oil daily before use during planting season and beginning of each season.

Sight glass is positioned behind the housing for protection purposes but easily seen without removing the housing. Oil level should be visible in sight glass. If oil needs added, remove housing and add grade 111 synthetic or PAO synthetic compressor oil until seen in middle of sight glass



Filling or Changing Hydraulic Air Compressor Oil

⚠ Deactivate SCV operating hydraulic compressor and turn off tractor before servicing

Filling Hydraulic Air Compressor Oil

Step 1: Remove cap

Step 2: Using a proper sized funnel add grade 111 synthetic or a PAO synthetic compressor oil until oil level is in middle of the sight glass

Step 3: Install cap

Changing Hydraulic Air Compressor Oil

Step 1: Remove cap for ventilation while draining

Step 2: Place container in position to catch oil while draining

Step 3: Remove drain plug to allow oil to drain

Step 4: Install removed drain plug after oil drained in entirety

Step 5: Add grade 111 synthetic or a PAO synthetic compressor oil until oil level is in middle of the sight glass

Step 6: Install cap



Remove housing to add or fill the pump with oil. See [page 27](#) for housing removal instructions.

2940-103A Control Box Maintenance

Daily when used – clean dirt/debris from inside of box, inspect all parts for damage/leaks & replace as needed.

Maintenance

Lubrication Symbols



Lubricate with grease at hourly interval indicated on symbol.

Lubrication Intervals

Residue Manager & Residue Manager/Coulter Combo

ALL COULTER HUB AND ROW CLEANER WHEEL ASSEMBLY BEARINGS ARE SEALED. REPACK BEARINGS AS NEEDED. COULTER HUB CASTLE NUT CAN BE TIGHTENED AS NEEDED.

IMPORTANT: The recommended service intervals are based on normal conditions; severe or unusual conditions may require more frequent lubrication.

AIR FITTINGS IN AIR BAGS CAN BE CLEANED WITH COMPRESSED AIR, KEEPING DIRT OUT OF THE COLLARS WILL ALLOW AIRLINE TO BE DISCONNECTED FROM AIR FITTING BY HAND MORE EASILY.

AIR BAG REPLACEMENT

2940-386

6" AIR BAG

2940-388

8" AIR BAG

TORQUE TO 115±15 LB-IN

5/8-11 HEX NUT GR 5
APPLY BLUE THREAD
LOCK

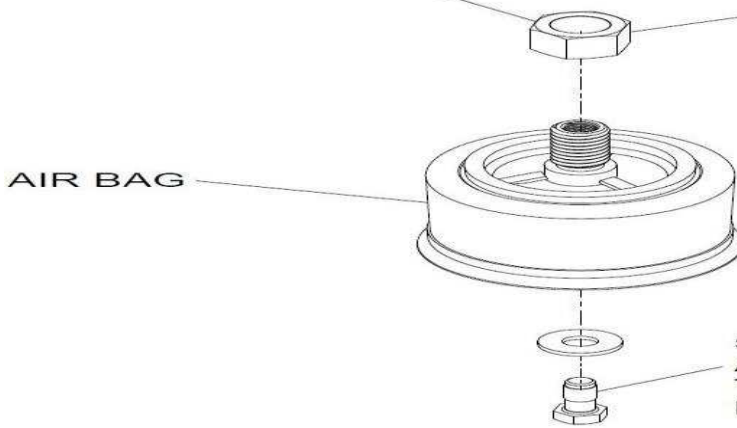

5/16"-18 X 3/4" HHCS GR 2
APPLY BLUE THREAD LOCK
TORQUE TO 36+/-12 LB-IN
MAX.

PARTS IDENTIFICATION

2940-049A

(For John Deere Planters with Heavy Duty Double Disc Scrapers)

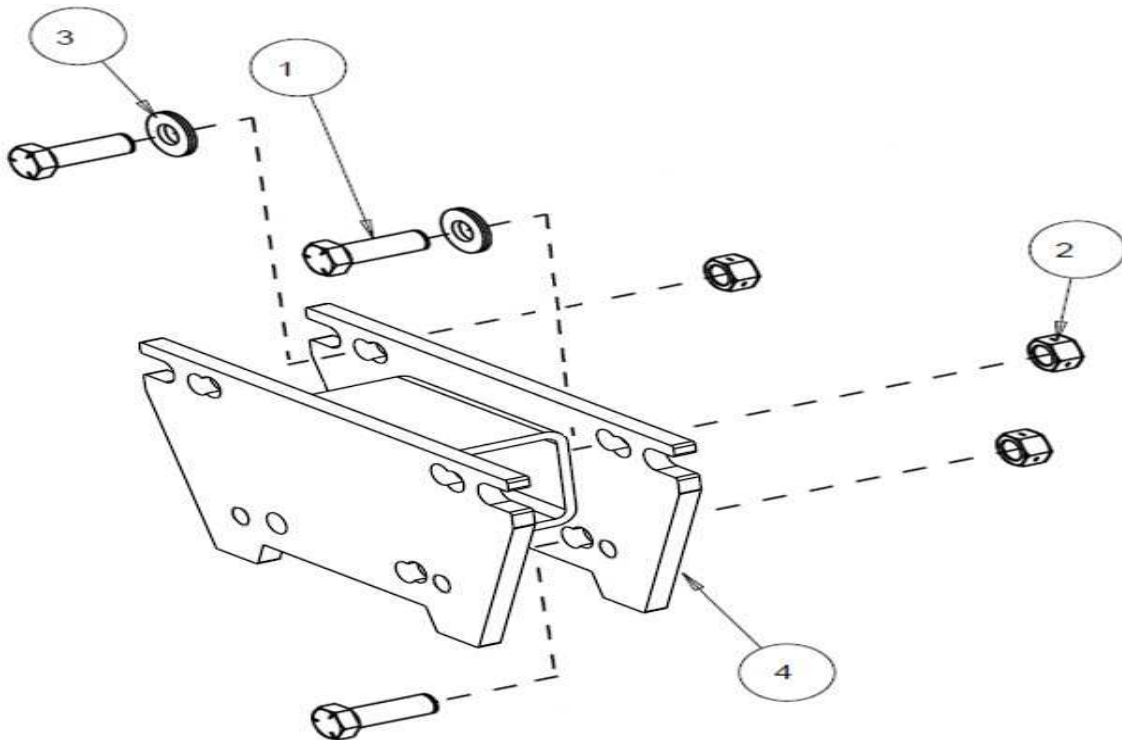

Item	Part Number	Description	Qty
1	2502-294	1/2-13 x 1-1/2 HHCS GR 5 ZP	3
2	2520-357	1/2-13 HEX LOCK NUT ZP	3
3	2526-355	1/2 FLAT WASHER HARDENED ZP	2
4	2940-220	MOUNT EXTENSION W.A.	1
5	5000-339	WASHER, MOUNT PLATE	2

2940-190A PARTS IDENTIFICATION

MANUFACTURED 07/17 – PRESENT

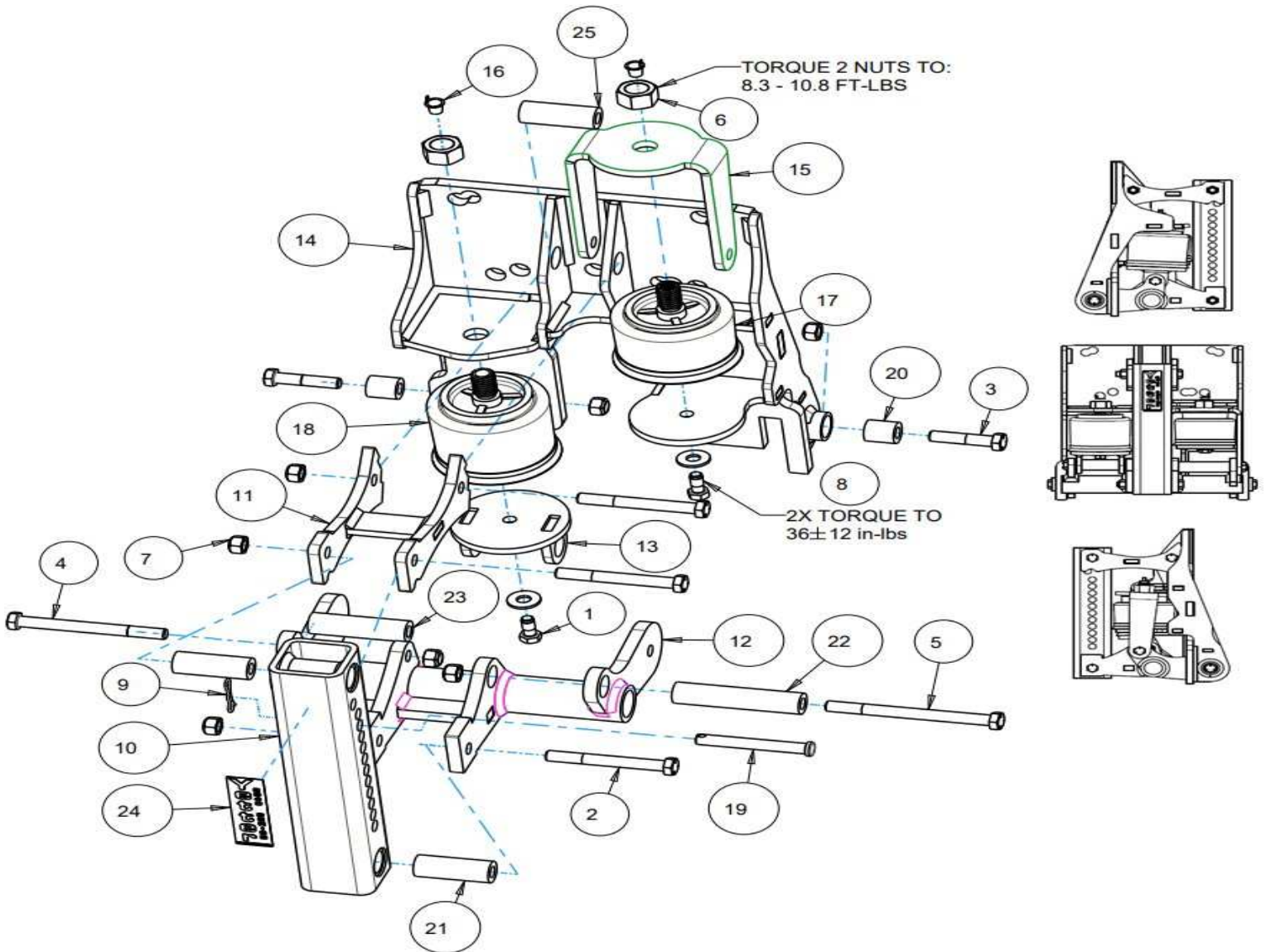

Item	Part Number	Description	Qty
1	2502-200	5/16 – 18 X ¼ HHCS W/ THREAD LOCK GR 2 ZP	2
2	2502-233	3/8 – 16 X 3 ¼ HHCS GR 5 ZP	3
3	2502-245	3/8 – 16 X 1 ¾ HHCS GR 5 ZP	2
4	2502-254	3/8 – 16 X 4 HHCS GR 5 ZP	1
5	2502-260	3/8 – 16 X 4 ½ HHCS GR 5 ZP	1
6	2520-455	5/8 – 11 HEX NUT ZP PATCH LOC GR 5	2
7	2520-601	3/8 – 16 HEX TOP LOCK GR C ZP	7
8	2526-201	5/16 STANDARD FLAT WASHER	2
9	2570-445	HAIRPIN COTTER, ZP	1
10	2940-210	ADJUSTMENT TUBE	1
11	2940-211A	UPPER LINK W.A.	1
12	2940-213	LOWER PARALLEL	1
13	2940-214	AIR BAG BRACKET W.A.	1
14	2940-222A	R.M. MOUNT PLATE W.A.	1
15	2940-309	UPFORCE TOP MOUNT	1
16	2940-340	AIR BAG CAP PLUG	2
17	2940-386	SHORTER AIR BAG	1
18	2940-388	LARGER AIR BAG	1
19	2940-399	PIN, ZP	1
20	2940-472	BUSHING	2
21	2940-473	BUSHING	2
22	2940-474	BUSHING	1
23	2940-478	.750" OD X .406" ID X 2.630" BUSHING	1
24	2940-590	YETTER VERTICAL DECAL	1
25	2940-677	PIVOT BUSHING	1

2940-192A PARTS IDENTIFICATION

MANUFACTURED 07/17 – PRESENT

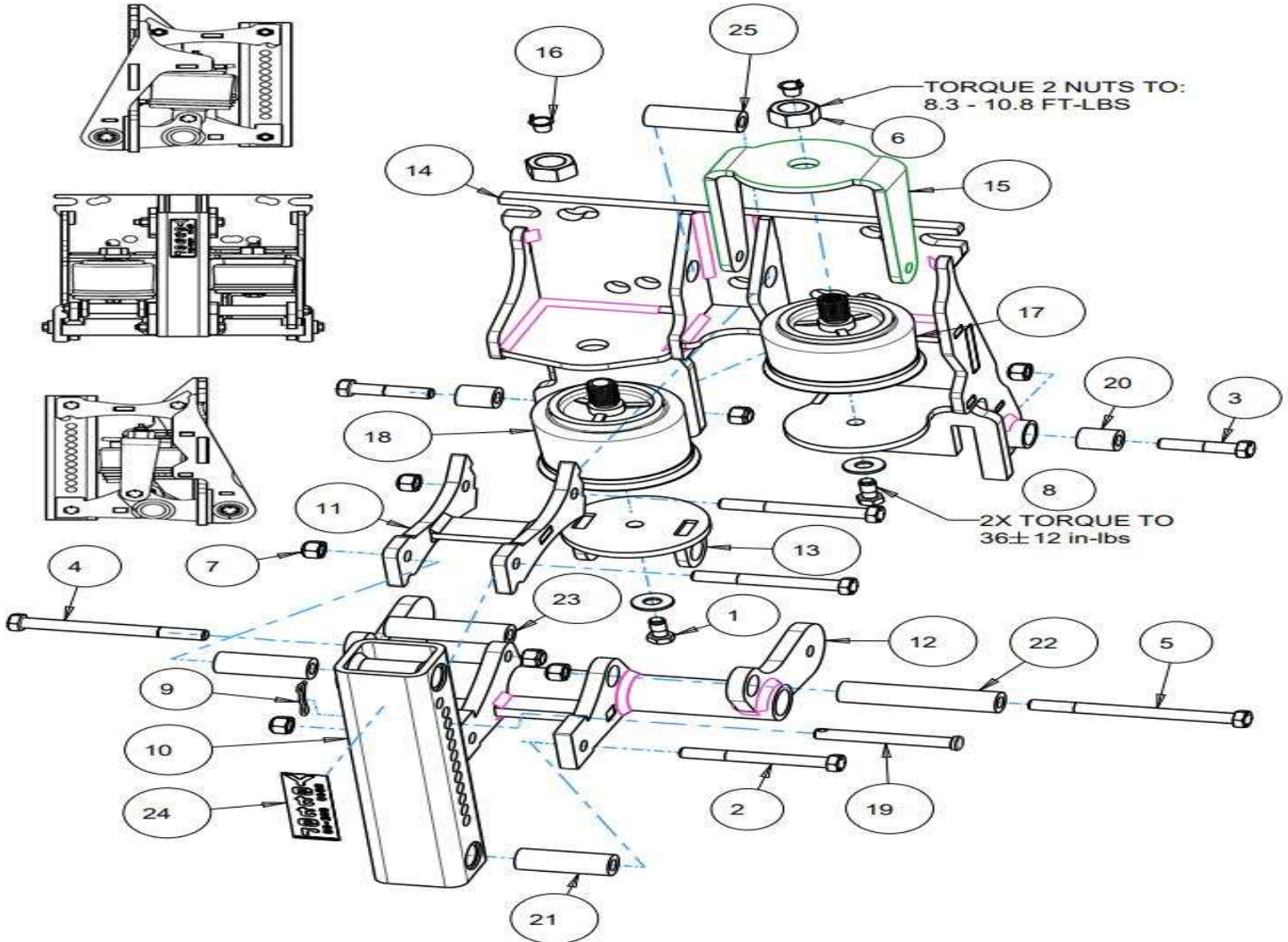

Item	Part Number	Description	Qty
1	2502-200	5/16 – 18 X 3/4 HHCS W/ THREAD LOCK GR 2 ZP	2
2	2502-233	3/8 – 16 X 3 1/4 HHCS GR 5 ZP	3
3	2502-245	3/8 – 16 X 1 3/4 HHCS GR 5 ZP	2
4	2502-254	3/8 – 16 X 4 HHCS GR 5 ZP	1
5	2502-260	3/8 – 16 X 4 1/2 HHCS GR 5 ZP	1
6	2520-455	5/8 – 11 HEX NUT ZP PATCH LOC GR 5	2
7	2520-601	3/8 – 16 HEX TOP LOCK GR C ZP	7
8	2526-201	5/16 STANDARD FLAT WASHER	2
9	2570-445	HAIRPIN COTTER, ZP	1
10	2940-210	ADJUSTMENT TUBE	1
11	2940-211A	UPPER LINK W.A.	1
12	2940-213	LOWER PARALLEL	1
13	2940-214	AIR BAG BRACKET W.A.	1
14	2940-223A	R.M. MOUNT PLATE W.A.	1
15	2940-309	UPFORCE TOP MOUNT	1
16	2940-340	AIR BAG CAP PLUG	2
17	2940-386	SHORTER AIR BAG	1
18	2940-388	LARGER AIR BAG	1
19	2940-399	PIN, ZP	1
20	2940-472	BUSHING	2
21	2940-473	BUSHING	2
22	2940-474	BUSHING	1
23	2940-478	.750" OD X .406" ID X 2.630" BUSHING	1
24	2940-590	YETTER VERTICAL DECAL	1
25	2940-677	PIVOT BUSHING	1

2940-001B & 2940-002B PARTS IDENTIFICATION

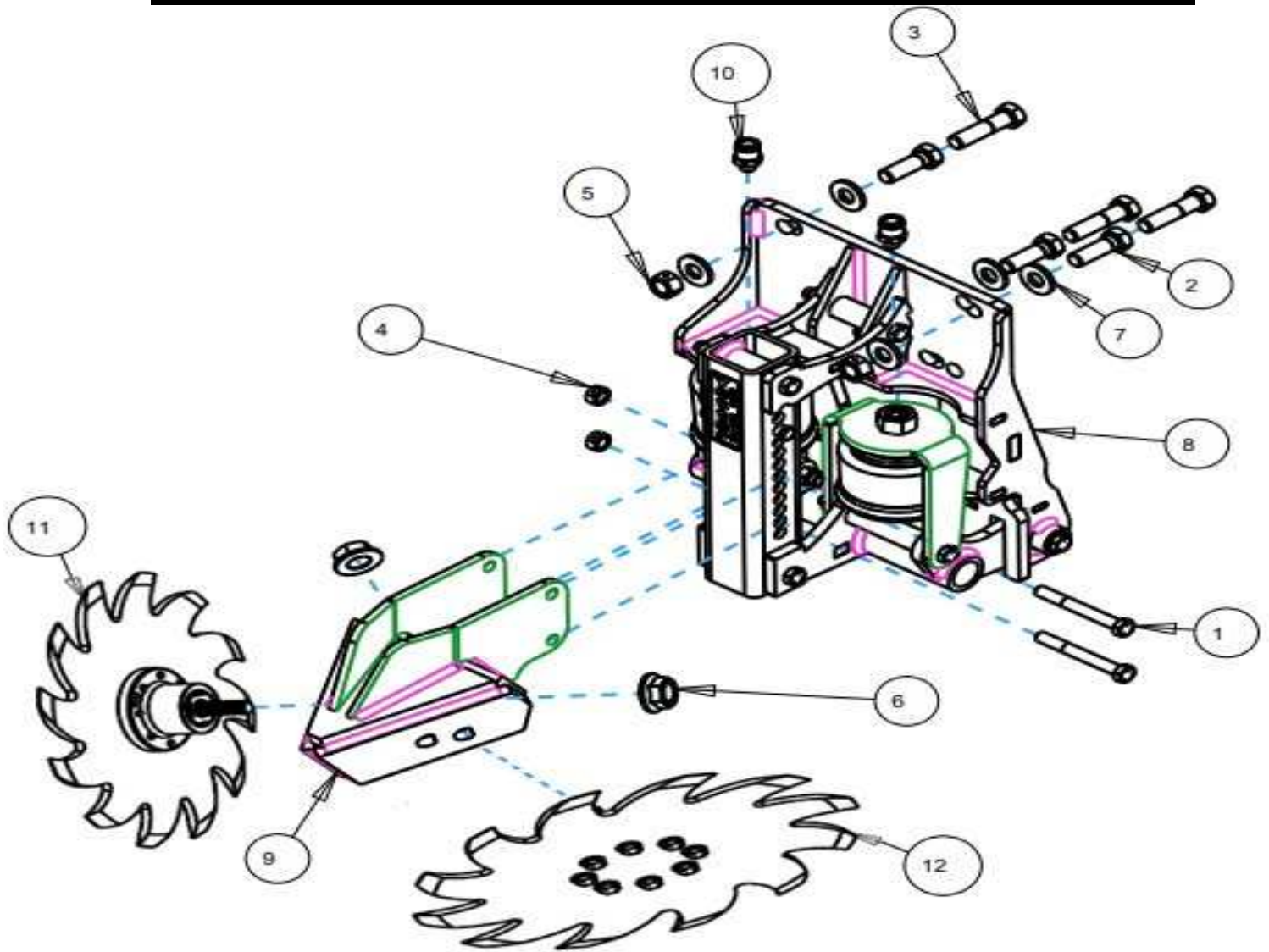

Item	Part Number	Description	Qty
1	2502-246	3/8-16 X 3 HHCS GR5 ZP	2
2	2502-294	1/2-13 X 1 1/2 HHCS GR5 ZP	3
3	2502-351	1/2-13 X 2 HHCS GR 5 ZP (MOUNTING TO AGCO 9000)	3
4	2520-255	3/8-16 LOCK HEX NUT, GR A, ZP	2
5	2520-357	1/2-13 LOCK HEX NUT, GR A, ZP	3
6	2520-465	5/8-11 SERRATED FLANGE HEX NUT, GR 8, ZP	2
7	2526-355	1/2 FLAT WASHER HARDENED ZP	6
8	2940-190A	PNEUMATIC R.M. MOUNT ASSEMBLY	1
9	2940-215	AIR ADJUST WIDE STEM W.A. (2940-001B)	1
	2940-216	AIR ADJUST NARROW STEM W.A. (2940-002B)	1
10	2940-380	3/8 PC X 1/8 BSPP O-RING STRAIGHT FITTING	2
11	2966-140	SPOKE WHEEL ASSEMBLY, RH, 3" D-BOLT	1
	2966-140-BW	BEVEL WHEEL ASSEMBLY, RH, 3" D-BOLT	1
	2966-140-BW-FW	BEVEL WHEEL ASSEMBLY, RH, 3" D-BOLT WITH FLOATER WHEEL	1
	2966-140-FW	SPOKE WHEEL ASSEMBLY, RH, 3" D-BOLT WITH FLOATER WHEEL	1
	2966-140-HD	HD SPOKE WHEEL ASSEMBLY, RH, 3" D-BOLT	1
	2966-140-HD-FW	HD SPOKE WHEEL ASSEMBLY, RH, 3" D-BOLT WITH FLOATER WHEEL	1
	2966-140-ST	SHARKTOOTH ASSEMBLY, RH, 3" D-BOLT	1
	2966-140-ST-FW	SHARKTOOTH ASSEMBLY, RH, 3" D-BOLT WITH FLOATER WHEEL	1
	2966-140-STF	SHARKTOOTH FINGER ASSEMBLY, RH, 3" D-BOLT	1
	2966-140-STF-FW	SHARKTOOTH FINGER ASSEMBLY, RH, 3" D-BOLT WITH FLOATER WHEEL	1
12	2966-141	SPOKE WHEEL ASSEMBLY, LH, 3" D-BOLT	1
	2966-141-BW	BEVEL WHEEL ASSEMBLY, LH, 3" D-BOLT	1
	2966-141-BW-FW	BEVEL WHEEL ASSEMBLY, LH, 3" D-BOLT WITH FLOATER WHEEL	1
	2966-141-FW	SPOKE WHEEL ASSEMBLY, LH, 3" D-BOLT WITH FLOATER WHEEL	1
	2966-141-HD	HD SPOKE WHEEL ASSEMBLY, LH, 3" D-BOLT	1
	2966-141-HD-FW	HD SPOKE WHEEL ASSEMBLY, LH, 3" D-BOLT WITH FLOATER WHEEL	1
	2966-141-ST	SHARKTOOTH ASSEMBLY, LH, 3" D-BOLT	1
	2966-141-ST-FW	SHARKTOOTH ASSEMBLY, LH, 3" D-BOLT WITH FLOATER WHEEL	1
	2966-141-STF	SHARKTOOTH FINGER ASSEMBLY, LH, 3" D-BOLT	1
	2966-141-STF-FW	SHARKTOOTH FINGER ASSEMBLY, LH, 3" D-BOLT WITH FLOATER WHEEL	1
NA	2967-392	SHIELD, RM-PAINTED (BEVEL & TAPER TOOTH WHEELS ONLY)	2

2940-003B & 2940-004B PARTS IDENTIFICATION

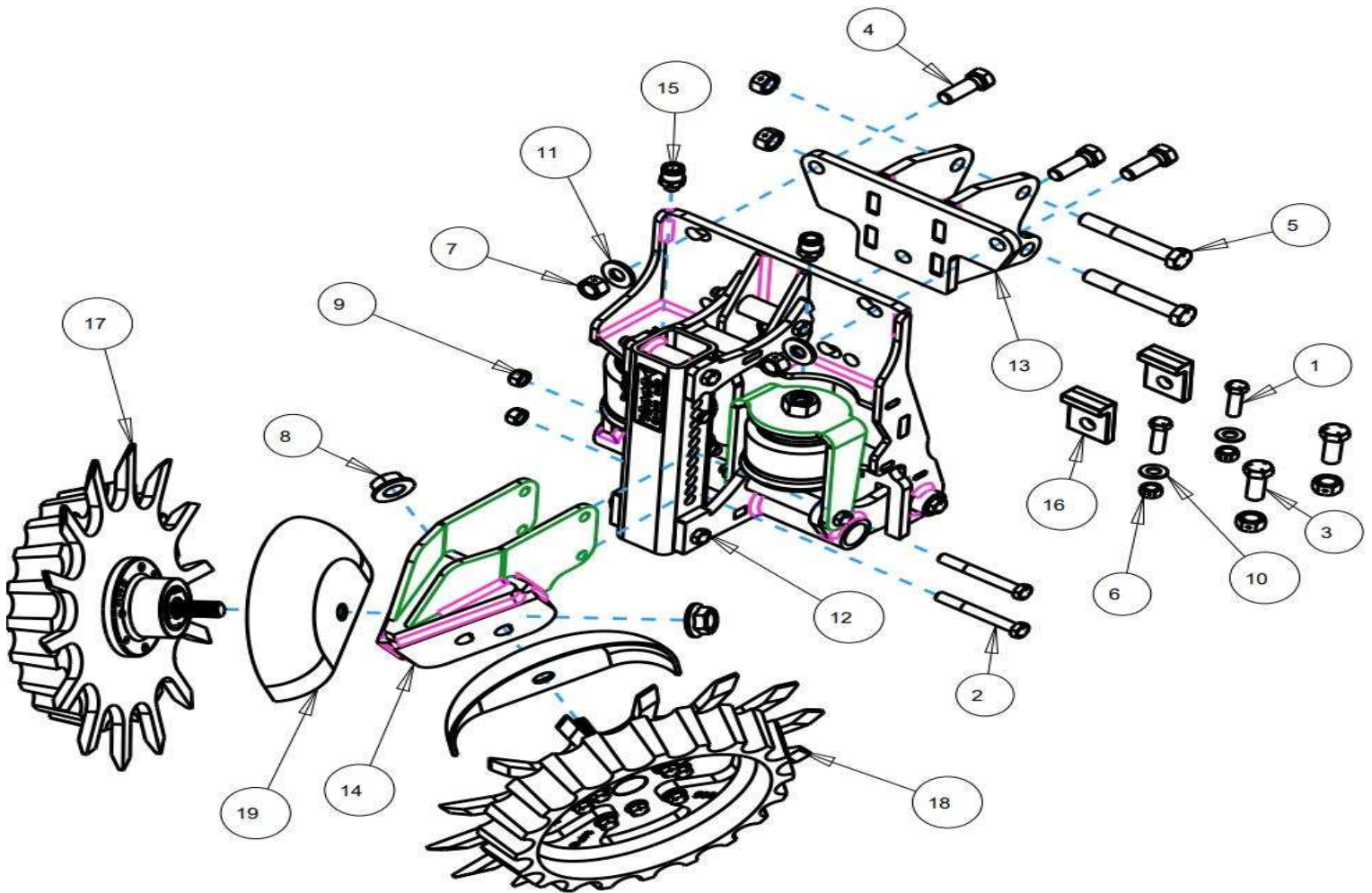

Item	Part Number	Description	Qty
1	2502-244	3/8 - 16 X 1 - 1/4 HHCS GR 5 ZP (FOR CYCLO STOP CASTING)	2
2	2502-246	3/8-16 X 3 HHCS GR5 ZP	2
3	2502-293	1/2-13 X 1 1/4 HHCS GR5	2
4	2502-294	1/2-13 X 1 1/2 HHCS GR5 ZP	3
5	2502-316	1/2-13 X 3-1/2 HHCS GR5 ZP	2
6	2520-255	3/8-16 LOCK HEX NUT, GR A, ZP (FOR CYCLO STOP CASTING)	2
7	2520-357	1/2-13 LOCK HEX NUT, GR A, ZP	7
8	2520-465	5/8-11 SERRATED FLANGE HEX NUT, GR 8, ZP	2
9	2520-601	3/8 - 16 HEX TOP LOCK NUT, GR C, ZP	2
10	2526-253	3/8 SAE FLAT WASHER ZP (FOR CYCLO STOP CASTING)	2
11	2526-355	1/2 FLAT WASHER HARDENED ZP	3
12	2940-190A	PNEUMATIC R.M. MOUNT ASSEMBLY	1
13	2940-209	CNH ADAPTOR BRACKET	1
	2966-293	CNH ADAPTOR BRACKET	1
14	2940-215	AIR ADJUST WIDE STEM W.A. (2940-003B)	1
	2940-216	AIR ADJUST NARROW STEM W.A. (2940-004B)	1
15	2940-380	3/8 PC X 1/8 BSPP O-RING STRAIGHT FITTING	2
16	2960-411	CYCLO STOP CASTING, LARGE HOLE	2
17	2966-140	SPOKE WHEEL ASSEMBLY, RH, 3" D-BOLT	1
	2966-140-BW	BEVEL WHEEL ASSEMBLY, RH, 3" D-BOLT	1
	2966-140-BW-FW	BEVEL WHEEL ASSEMBLY, RH, 3" D-BOLT WITH FLOATER WHEEL	1
	2966-140-FW	SPOKE WHEEL ASSEMBLY, RH, 3" D -BOLT WITH FLOATER WHEEL	1
	2966-140-HD	HD SPOKE WHEEL ASSEMBLY, RH, 3" D-BOLT	1
	2966-140-HD-FW	HD SPOKE WHEEL ASSEMBLY, RH, 3" D-BOLT WITH FLOATER WHEEL	1
	2966-140-ST	SHARKTOOTH ASSEMBLY, RH, 3" D-BOLT	1
	2966-140-ST-FW	SHARKTOOTH ASSEMBLY, RH, 3" D-BOLT WITH FLOATER WHEEL	1
	2966-140-STF	SHARKTOOTH FINGER ASSEMBLY, LH, 3" D-BOLT L	1
	2966-140-STF-FW	SHARKTOOTH FINGER ASSEMBLY, LH, 3" D-BOLT WITH FLOATER WHEEL	1
18	2966-141	SPOKE WHEEL ASSEMBLY, LH, 3" D-BOLT	1
	2966-141-BW	BEVEL WHEEL ASSEMBLY, LH, 3" D-BOLT	1
	2966-141-BW-FW	BEVEL WHEEL ASSEMBLY, LH, 3" D-BOLT WITH FLOATER WHEEL	1
	2966-141-FW	SPOKE WHEEL ASSEMBLY, LH, 3" D-BOLT WITH FLOATER WHEEL	1
	2966-141-HD	HD SPOKE WHEEL ASSEMBLY, LH, 3" D-BOLT	1
	2966-141-HD-FW	HD SPOKE WHEEL ASSEMBLY, LH, 3" D-BOLT WITH FLOATER WHEEL	1
	2966-141-ST	SHARKTOOTH ASSEMBLY, LH, 3" D-BOLT	1
	2966-141-ST-FW	SHARKTOOTH ASSEMBLY, LH, 3" D-BOLT WITH FLOATER WHEEL	1
	2966-141-STF	SHARKTOOTH FINGER ASSEMBLY, LH, 3" D-BOLT L	1
	2966-141-STF-FW	SHARKTOOTH FINGER ASSEMBLY, LH, 3" D-BOLT WITH FLOATER WHEEL	1
19	2967-392	SHIELD (BEVEL& TAPER TOOTH WHEELS ONLY)	2

2940-005B & 006B PARTS IDENTIFICATION

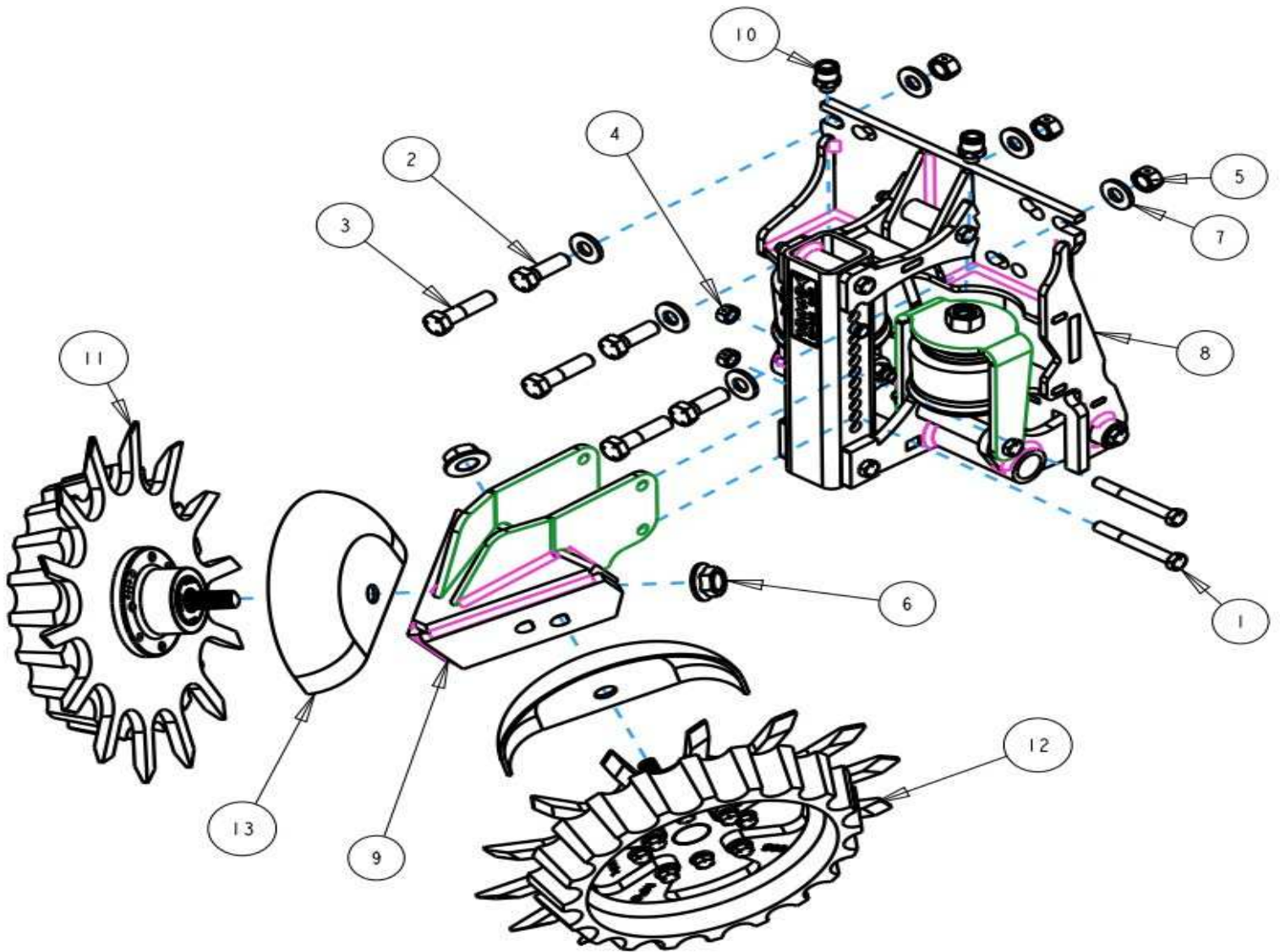

Item	Part Number	Description	Qty
1	2502-246	3/8-16 X 3 HHCS GR5 ZP	2
2	2502-294	1/2-13 X 1 1/2 HHCS GR5 ZP	3
3	2502-351	1/2-13 X 2 HHCS GR5 ZP	3
4	2520-255	3/8-16 LOCK NUT, GR A, ZP	2
5	2520-357	1/2-13 LOCK HEX NUT, GR A, ZP	3
6	2520-465	5/8-11 SERRATED FLANGE NUT, GR 8, ZP	2
7	2526-355	1/2 FLAT WASHER HARDENED ZP	6
8	2940-192A	PNEUMATIC R.M. MOUNT ASSEMBLY	1
9	2940-215	AIR ADJUST WIDE STEM W.A. (2940-005B)	1
	2940-216	AIR ADJUST NARROW STEM W.A. (2940-006B)	1
10	2940-380	3/8 PC X 1/8 BSPP O-RING STRAIGHT FITTING	2
11	2966-140	SPOKE WHEEL ASSEMBLY, RH, 3" D-BOLT	1
	2966-140-BW	BEVEL WHEEL ASSEMBLY, RH, 3" D-BOLT	1
	2966-140-BW-FW	BEVEL WHEEL ASSEMBLY, RH, 3" D-BOLT WITH FLOATER WHEEL	1
	2966-140-FW	SPOKE WHEEL ASSEMBLY, RH, 3" D-BOLT WITH FLOATER WHEEL	1
	2966-140-HD	HD SPOKE WHEEL ASSEMBLY, RH, 3" D-BOLT	1
	2966-140-HD-FW	HD SPOKE WHEEL ASSEMBLY, RH, 3" D-BOLT WITH FLOATER WHEEL	1
	2966-140-ST	SHARKTOOTH ASSEMBLY, RH, 3" D-BOLT	1
	2966-140-ST-FW	SHARKTOOTH ASSEMBLY, RH, 3" D-BOLT WITH FLOATER WHEEL	1
	2966-140-STF	SHARKTOOTH FINGER ASSEMBLY, RH, 3" D-BOLT	1
	2966-140-STF-FW	SHARKTOOTH FINGER ASSEMBLY, RH, 3" D-BOLT WITH FLOATER WHEEL	1
12	2966-141	SPOKE WHEEL ASSEMBLY, LH, 3" D-BOLT	1
	2966-141-BW	BEVEL WHEEL ASSEMBLY, LH, 3" D-BOLT	1
	2966-141-BW-FW	BEVEL WHEEL ASSEMBLY, LH, 3" D-BOLT WITH FLOATER WHEEL	1
	2966-141-FW	SPOKE WHEEL ASSEMBLY, LH, 3" D-BOLT WITH FLOATER WHEEL	1
	2966-141-HD	HD SPOKE WHEEL ASSEMBLY, LH, 3" D-BOLT	1
	2966-141-HD-FW	HD SPOKE WHEEL ASSEMBLY, LH, 3" D-BOLT WITH FLOATER WHEEL	1
	2966-141-ST	SHARKTOOTH ASSEMBLY, LH, 3" D-BOLT	1
	2966-141-ST-FW	SHARKTOOTH ASSEMBLY, LH, 3" D-BOLT WITH FLOATER WHEEL	1
	2966-141-STF	SHARKTOOTH FINGER ASSEMBLY, LH, 3" D-BOLT	1
	2966-141-STF-FW	SHARKTOOTH FINGER ASSEMBLY, LH, 3" D-BOLT WITH FLOATER WHEEL	1
13	2967-392	SHIELD (BEVEL & TAPER TOOTH WHEEL ONLY)	2

2940-126A PARTS IDENTIFICATION

MANUFACTURED 07/17 – PRESENT

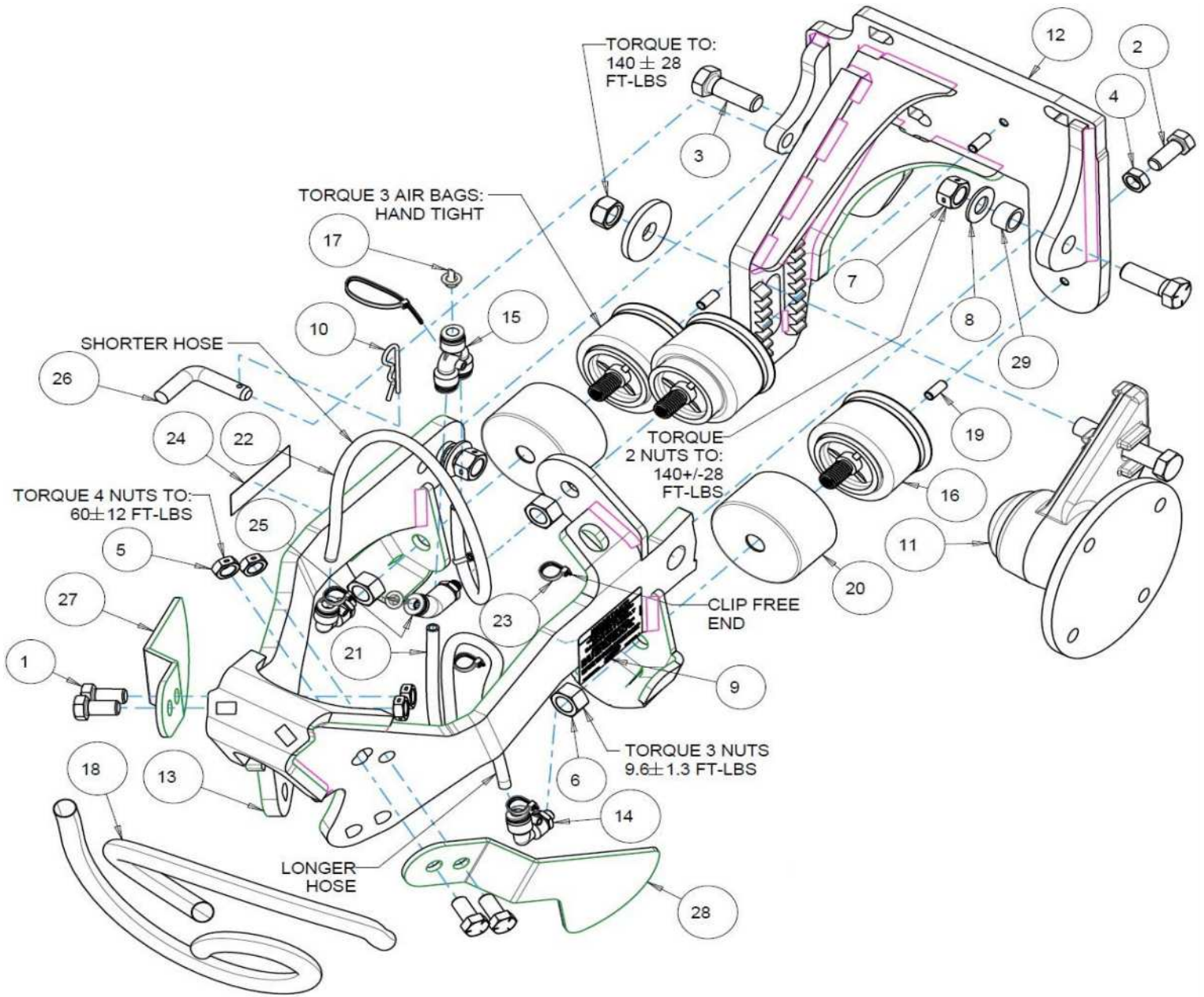

Item	Part #	Description	Qty
1	2502-292	½-13 X 1 HHCS GR 5 ZP	4
2	2502-293	½-13 X 1 ¼ HHCS GR 5 ZP	1
3	2502-331	5/8-11 X 1 ¼ HHCS GR 5 ZP	2
4	2520-356	½-13 JAM HEX NUT ZP	1
5	2520-364	½-13 JAM HEX LOCK NUT	4
6	2520-455	5/8-11 HEX NUT WITH PATCH LOC, GR 5 ZP	3
7	2520-459	5/8-11 HEX LOCK NUT ZP	2
8	2526-454	5/8 SAE FLAT WASHER HARDENED ZP	2
9	2565-505	FRAME HEIGHT DECAL	1
10	2570-446	.125 HAIRPIN COTTER ZP	1
11	2940-121	ASSEMBLY, COULTER HUB	1
12	2940-230	FACEPLATE W.A.	1
13	2940-231	COMBO ARM W.A.	1
14	2940-381	3/8 PC X 1/8 BSPP O-RING 90 DEGREE	2
15	2940-383	3/8 PC WYE FITTING	1

Item	Part #	Description	Qty
16	2940-386	SHORTER AIR BAG	3
17	2940-389	RUBBER AIR BAG PLUG	2
18	2940-508	HOSE SLEEVE	2
19	2940-560	SET SCREW, .313-18 X .750 W/ THREAD LOCK	3
20	2940-569	AIR BAG SHIELD	2
21	2940-571	HOSE, LH COMBO 2940 AIR SYSTEMS	1
22	2940-572	HOSE, RH COMBO 2940 AIR SYSTEMS	1
23	2940-577	ZIP TIE	5
24	2940-589	YETTER HORIZONTAL DECAL 1" X 3"	2
25	2940-609	3/8 PC X 1/8 BSPP O-RING	1
26	2967-613	TITAN PIN, JD ZP	1
27	2967-630	SCRAPER, RH	1
28	2967-631	SCRAPER, LH	1
29	6000-335	9/16" BUSHING	2

2940-130A PARTS IDENTIFICATION

MANUFACTURED 07/17 – PRESENT

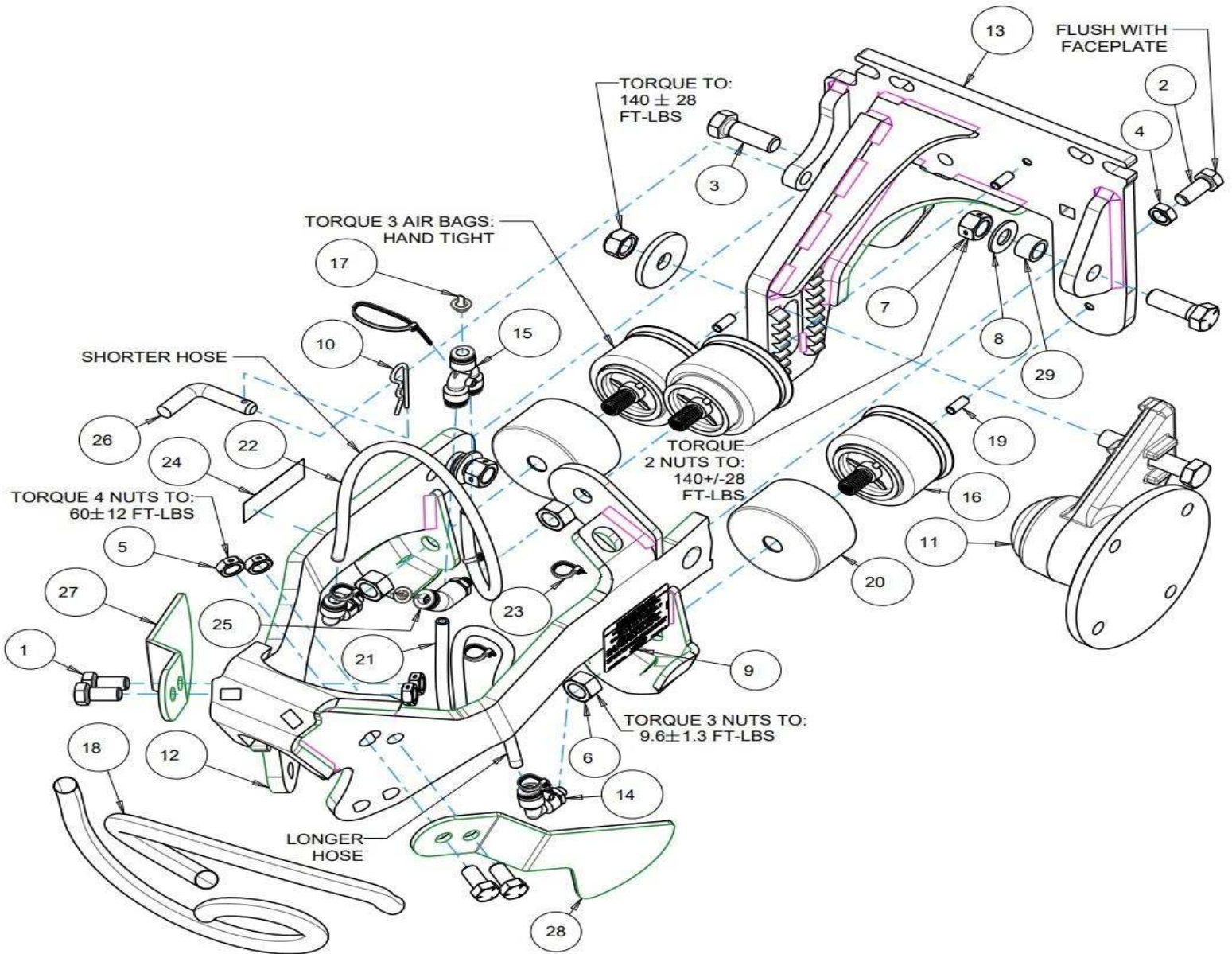

Item	Part #	Description	Qty
1	2502-292	½-13 X 1 HHCS GR 5 ZP	4
2	2502-293	½-13 X 1 ¼ HHCS GR 5 ZP	1
3	2502-331	5/8-11 X 1 ¾ HHCS GR 5 ZP	2
4	2520-356	½-13 JAM HEX NUT ZP	1
5	2520-364	½-13 JAM HEX LOCK NUT	4
6	2520-455	5/8-11 HEX NUT WITH PATCH LOC, GR 5 ZP	3
7	2520-459	5/8-11 HEX LOCK NUT ZP	2
8	2526-454	5/8 SAE FLAT WASHER HARDENED ZP	2
9	2565-505	FRAME HEIGHT DECAL	1
10	2570-446	.125 HAIRPIN COTTER ZP	1
11	2940-121	ASSEMBLY, COULTER HUB	1
12	2940-231	COMBO ARM W.A.	1
13	2940-232	FACEPLATE W.A.	1
14	2940-381	3/8 PC X 1/8 BSPP O-RING 90 DEGREE	2
15	2940-383	3/8 PC WYE FITTING	1

Item	Part #	Description	Qty
16	2940-386	SHORTER AIR BAG	3
17	2940-389	RUBBER AIR BAG PLUG	2
18	2940-508	HOSE SLEEVE	2
19	2940-560	SET SCREW, .313-18 X .750 W/ THREAD LOCK	3
20	2940-569	AIR BAG SHIELD	2
21	2940-571	HOSE, LH COMBO 2940 AIR SYSTEMS	1
22	2940-572	HOSE, RH COMBO 2940 AIR SYSTEMS	1
23	2940-577	ZIP TIE	5
24	2940-589	YETTER HORIZONTAL DECAL 1" X 3"	2
25	2940-609	3/8 PC X 1/8 BSPP O-RING	1
26	2967-613	TITAN PIN, JD ZP	1
27	2967-630	SCRAPER, RH	1
28	2967-631	SCRAPER, LH	1
29	6000-335	9/16" BUSHING	2

2940-007B PARTS IDENTIFICATION

JD 7000, AGCO 6000 & 8000
KINZE 2000, 3000, 4900

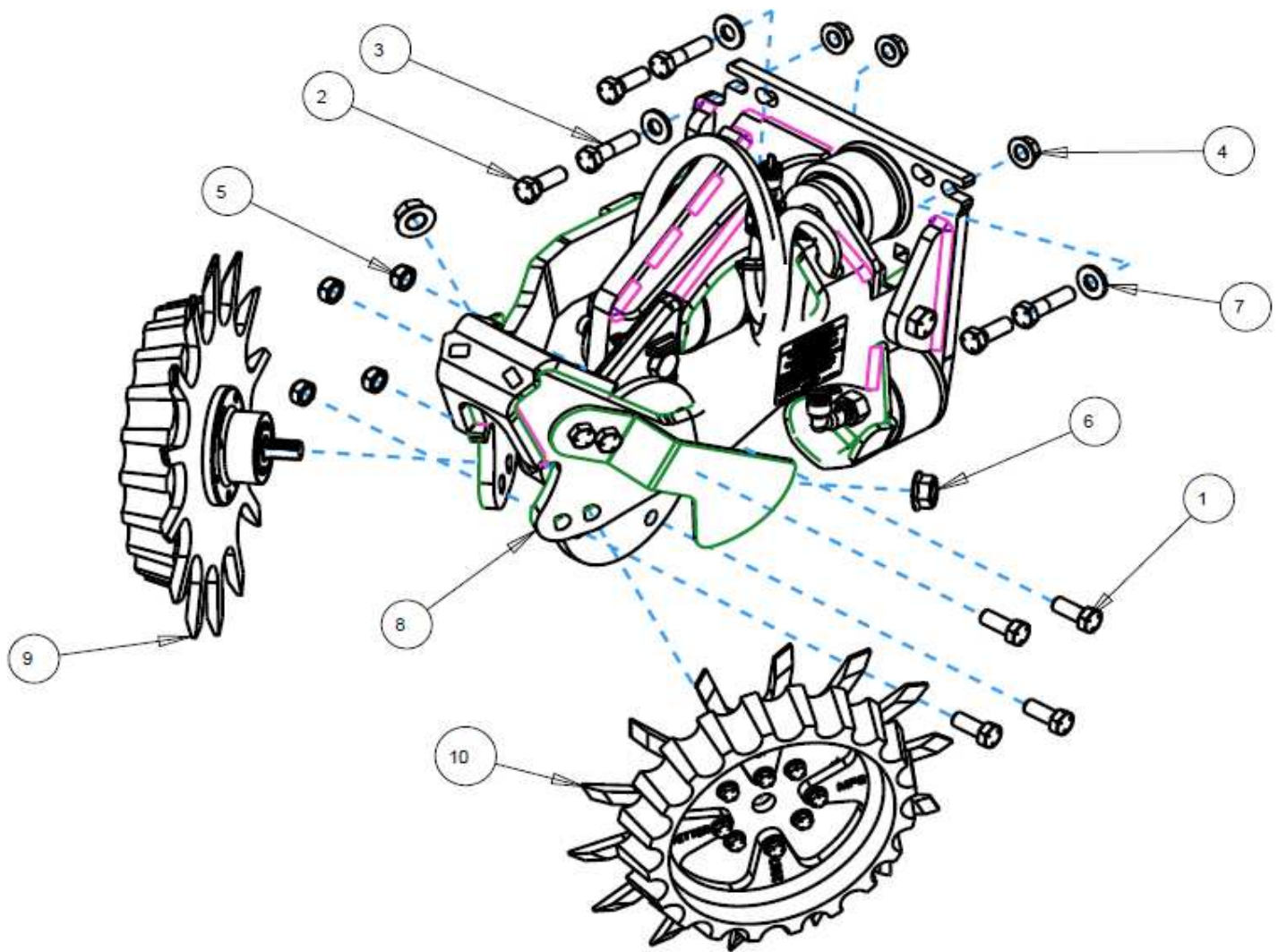

Item	Part Number	Description	Qty
1	2502-293	½-13 X 1 ¼ HHCS GR 5 ZP	4
2	2502-294	½-13 X 1 ½ HHCS GR 5 ZP	3
3	2502-351	½-13 X 2 HHCS GR 5 ZP (FOR MOUNTING TO AGCO 9000)	3
4	2520-361	½-13 FLANGE WHIZLOCK HEX NUT GR 5 ZP	3
5	2520-362	½-13 HEX LOCK NUT GR C ZP	4
6	2520-465	5/8-11 SERRATED FLANGE HEX NUT GR 8 ZP	2
7	2526-355	½ FLAT WASHER HARDENED ZP	3
8	2940-130A	PNEUMATIC COMBO SUBASSEMBLY FOR JD 1700 & 7200, AGCO 9000	1
9	2966-116-FW	SPOKE WHEEL ASSEMBLY, RH, 2 3/4" D-BOLT WITH FLOATER WHEEL	1
	2966-116-ST-FW	SHARK TOOTH WHEEL ASSEMBLY, RH, 2 3/4" D-BOLT WITH FLOATER WHEEL	1
	2966-116-BW-FW	BEVEL WHEEL ASSEMBLY, RH, 2 3/4" D-BOLT WITH FLOATER WHEEL	1
	2966-116-STF-FW	SHARK TOOTH FINGER WHEEL ASSEMBLY, RH, 2 3/4" D-BOLT WITH FLOATER WHEEL	1
10	2966-117-FW	SPOKE WHEEL ASSEMBLY, LH, 2 3/4" D-BOLT WITH FLOATER WHEEL	1
	2966-117-ST-FW	SHARK TOOTH WHEEL ASSEMBLY, LH, 2 3/4" D-BOLT WITH FLOATER WHEEL	1
	2966-117-BW-FW	BEVEL WHEEL ASSEMBLY, LH, 2 3/4" D-BOLT WITH FLOATER WHEEL	1
	2966-117-STF-FW	SHARK TOOTH FINGER WHEEL ASSEMBLY, LH, 2 3/4" D-BOLT WITH FLOATER WHEEL	1

2940-010B PARTS IDENTIFICATION

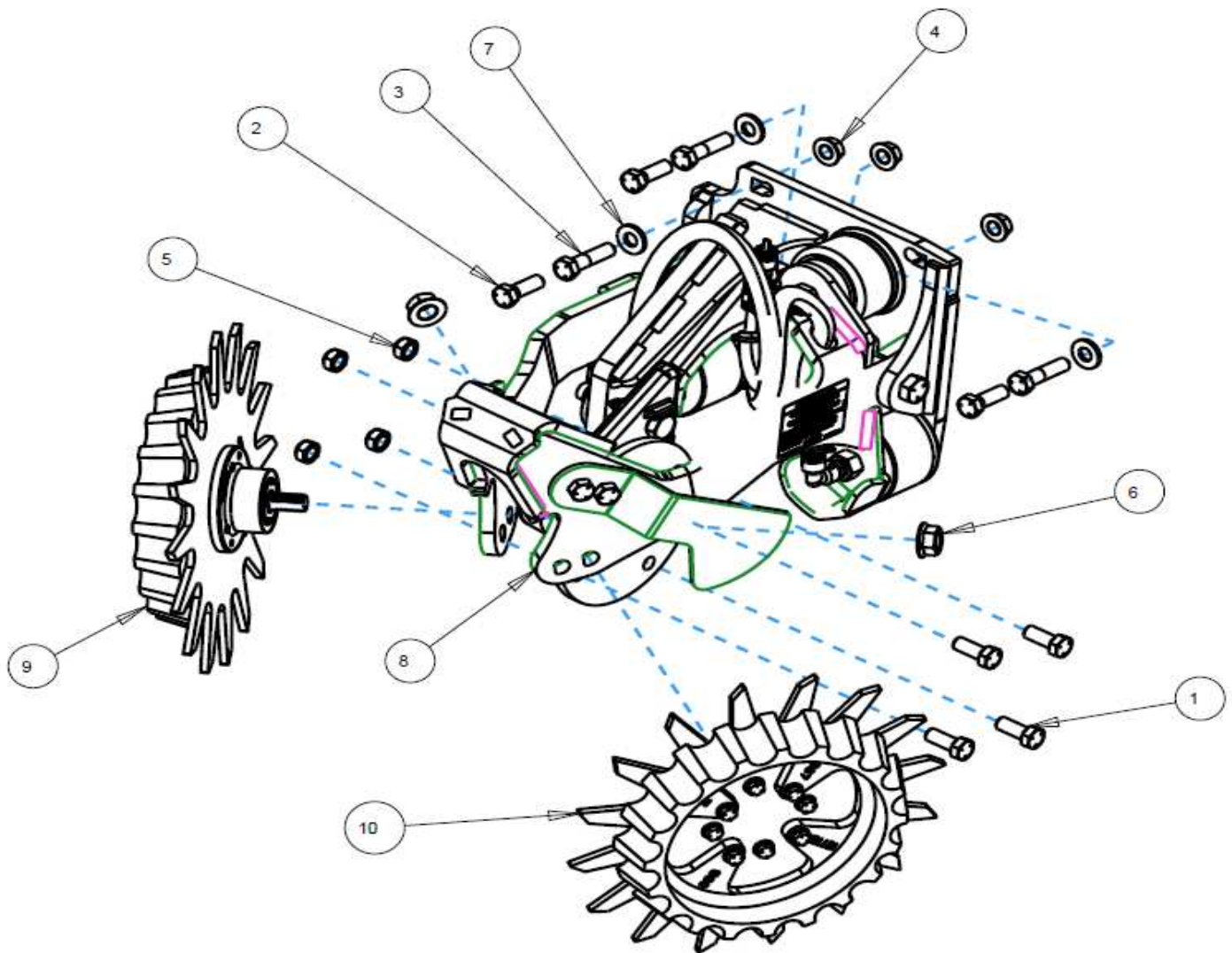

JD 1700-7200, AGCO 9000

Item	Part Number	Description	Qty
1	2502-293	½-13 X 1 ¼ HHCS GR 5 ZP	4
2	2502-294	½-13 X 1 ½ HHCS GR 5 ZP	3
3	2502-351	½-13 X 2 HHCS GR 5 ZP (FOR MOUNTING TO AGCO 9000)	3
4	2520-361	½-13 FLANGE WHIZLOCK HEX NUT GR 5 ZP	3
5	2520-362	½-13 HEX LOCK NUT GR C ZP	4
6	2520-465	5/8-11 SERRATED FLANGE HEX NUT GR 8 ZP	2
7	2526-355	½ FLAT WASHER HARDENED ZP	3
8	2940-126A	PNEUMATIC COMBO SUBASSEMBLY	1
9	2966-116-FW	SPOKE WHEEL ASSEMBLY, RH, 2 3-4" D-BOLT WITH FLOATER WHEEL	1
	2966-116-ST-FW	SHARK TOOTH WHEEL ASSEMBLY, RH, 2 3/4" D-BOLT WITH FLOATER WHEEL	1
	2966-116-BW-FW	BEVEL WHEEL ASSEMBLY, RH, 2 3/4" D-BOLT WITH FLOATER WHEEL	1
	2966-116-STF-FW	SHARK TOOTH FINGER WHEEL ASSEMBLY, RH, 2 3/4" D-BOLT WITH FLOATER WHEEL	1
10	2966-117-FW	SPOKE WHEEL ASSEMBLY, LH, 2 3-4" D-BOLT WITH FLOATER WHEEL	1
	2966-117-ST-FW	SHARK TOOTH WHEEL ASSEMBLY, LH, 2 3/4" D-BOLT WITH FLOATER WHEEL	1
	2966-117-BW-FW	BEVEL WHEEL ASSEMBLY, LH, 2 3/4" D-BOLT WITH FLOATER WHEEL	1
	2966-117-STF-FW	SHARK TOOTH FINGER WHEEL ASSEMBLY, LH, 2 3/4" D-BOLT WITH FLOATER WHEEL	1

PARTS IDENTIFICATION

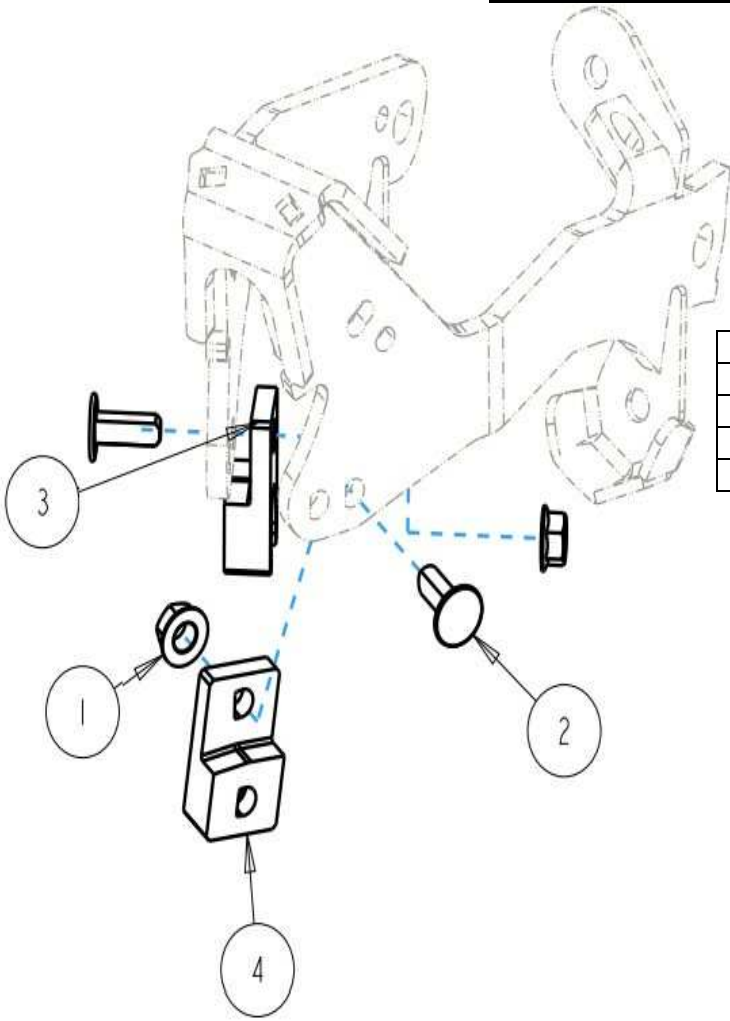

2940-092 DROP DOWN KIT

ITEM	PART #	DESCRIPTION	QTY
1	2520-464	5/8-11 WHIZLOCK HEX NU, GR 8, ZP	2
2	2940-672	FLAT TOP D-BOLT	2
3	2940-673	DROP DOWN, RH	1
4	2940-674	DROP DOWN, LH	1

2940-093 SNAKEHEAD EXT. KIT

ITEM	PART #	DESCRIPTION	QTY
1	2502-237	3/8-16 X 1 HHCS GR 5 ZP	4
2	2502-246	3/8-16 X 3 HHCS GR 5 ZP	2
3	2520-255	3/8-16 LOCK HEX NUT GR A ZP	6
4	2940-239	SNAKEHEAD EXT. BRACKET W.A.	2

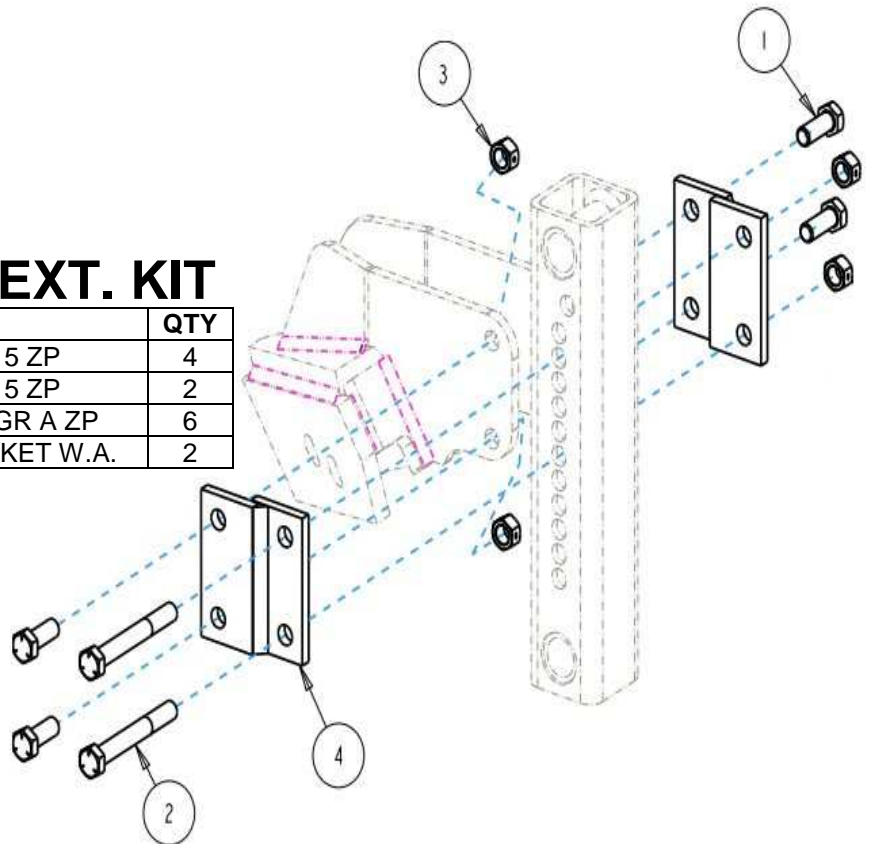

PARTS IDENTIFICATION

2966-140 RIGHT HAND WHEEL ASSEMBLY (ROW CLEANER ONLY)

2966-141 LEFT HAND WHEEL ASSEMBLY (ROW CLEANER ONLY)

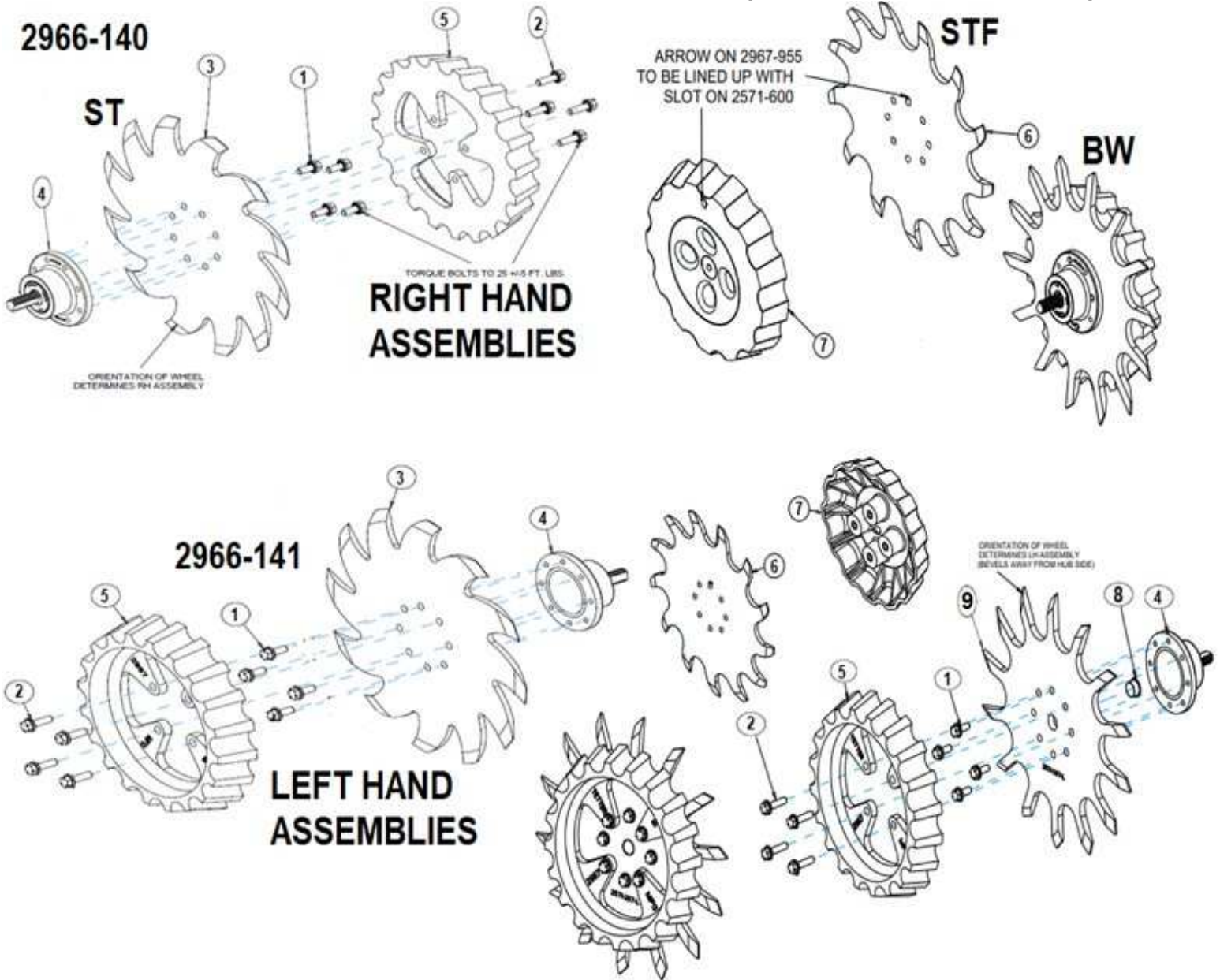

ITEM	PART #	DESCRIPTION	QTY
1	2502-220	5/16-18 X ¾ HHFS GR5 ZP	4
2	2502-221	5/16-18 X 1 GR 5 ZP	4
3	2571-286	SHARKTOOTH WHEEL, 8 BOLT	1
4	2965-500	HUB ASSEMBLY, 1.406 SPINDLE	1
5	2967-560	FLOATER WHEEL	1
6	2571-600	SHARKTOOTH FINGER WHEEL	1
7	2967-955	STF TIMED FLOATER WHEEL	1
8	2570-994	BEVEL WHEEL CENTER HOLE PLUG (ONLY USED ON BW)	1
9	2571-287-L	13" BEVEL WHEEL, 8 BOLT, LH	1
9	2571-287-R	13" BEVEL WHEEL, 8 BOLT, RH	1
	2571-289	TAPER TOOTH WHEEL (NOT SHOWN)	1

***FLOATER WHEELS AREN'T NEEDED ON ROW CLEANER ONLY WHEEL ASSEMBLIES**

PARTS IDENTIFICATION

2966-116 RIGHT HAND WHEEL ASSEMBLY (COULTER COMBO ONLY)

2966-117 LEFT HAND WHEEL ASSEMBLY (COULTER COMBO ONLY)

2966-116

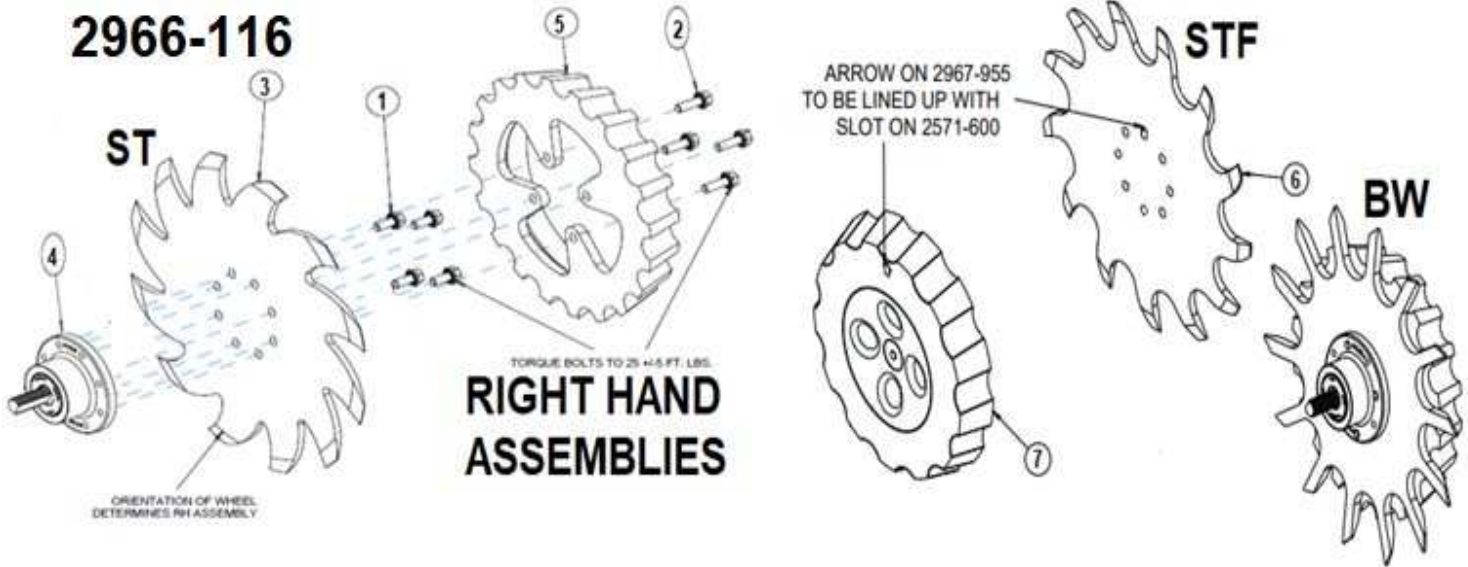

2966-117

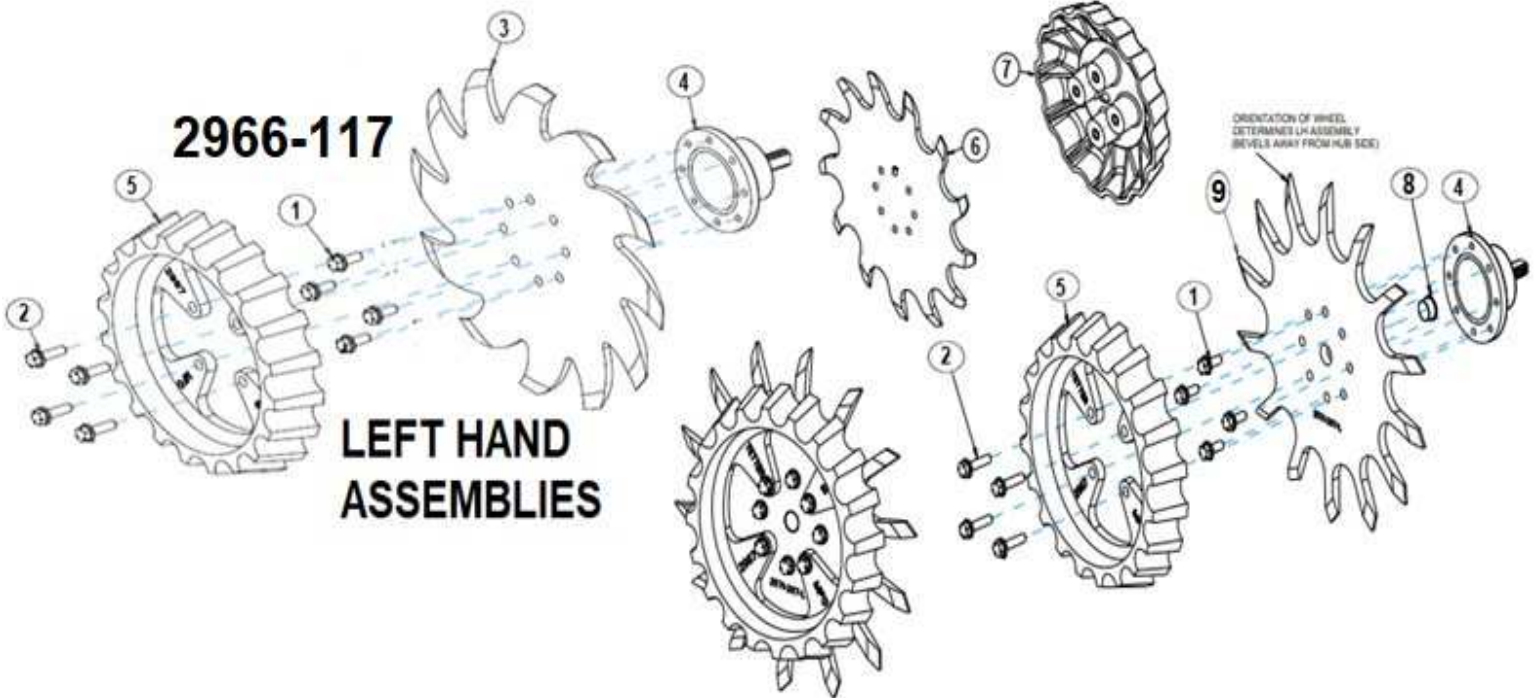

ITEM	PART #	DESCRIPTION	QTY
1	2502-220	5/16-18 X ¾ HHFS GR5 ZP	4
2	2502-221	5/16-18 X 1 GR 5 ZP	4
3	2571-286	SHARKTOOTH WHEEL, 8 BOLT	1
4	2965-502	HUB ASSEMBLY, 1.157 SPINDLE	1
5	2967-560	FLOATER WHEEL	1
6	2571-600	SHARKTOOTH FINGER WHEEL, 8 BOLT	1
7	2967-955	STF TIMED FLOATER WHEEL, 8 BOLT	1
8	2570-994	BEVEL WHEEL CENTER HOLE PLUG (ONLY USED ON BW)	1
9	2571-287-L	13" BEVEL WHEEL, 8 BOLT, LH	1
9	2571-287-R	13" BEVEL WHEEL, 8 BOLT, RH	1
	2571-289	TAPER TOOTH WHEEL, 8 BOLT (NOT SHOWN)	1

PARTS IDENTIFICATION

2940-115
COULTER SUBASSEMBLY FOR
JD 7000, AGCO 6000, 8000, KINZE 2000, 3000, 4900

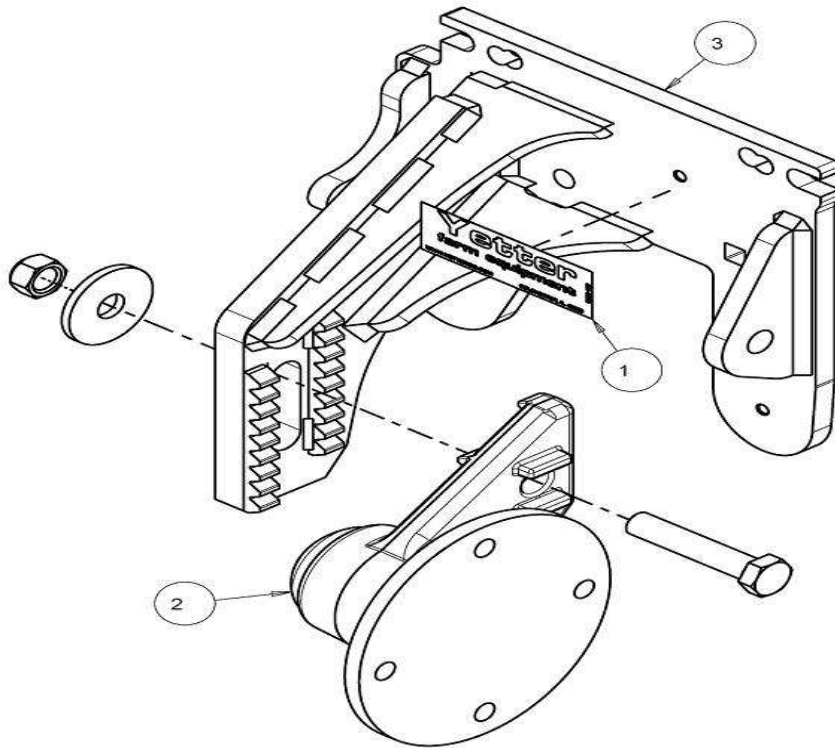

Item	Part Number	Description	Qty
1	2565-162	YETTER DECAL, 1 ½ X 4 ½	1
2	2940-121	ASSEMBLY, COULTER HUB	1
3	2940-232	FACEPLATE W.A., JD 7000, AGCO 6000 & 8000, KINZE	1

2940-116
COULTER SUBASSEMBLY FOR
JD 1700, 7200, AGCO 9000

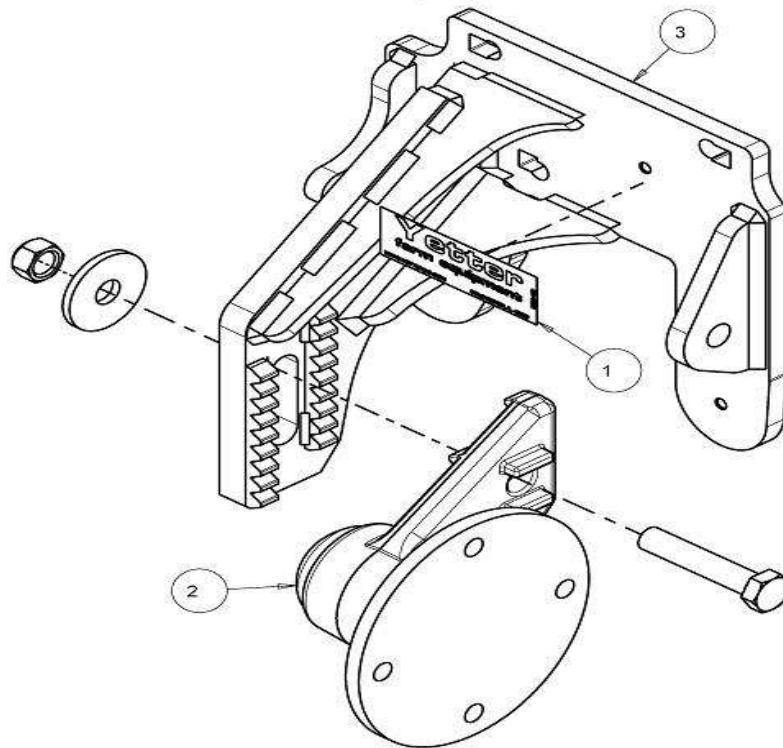

Item	Part Number	Description	Qty
1	2565-162	YETTER DECAL, 1 ½ X 4 ½	1
2	2940-121	ASSEMBLY, COULTER HUB	1
3	2940-230	FACEPLATE W.A., JD 1700 & 7200, AGCO 9000	1

PARTS IDENTIFICATION

2940-121 Coulter Hub

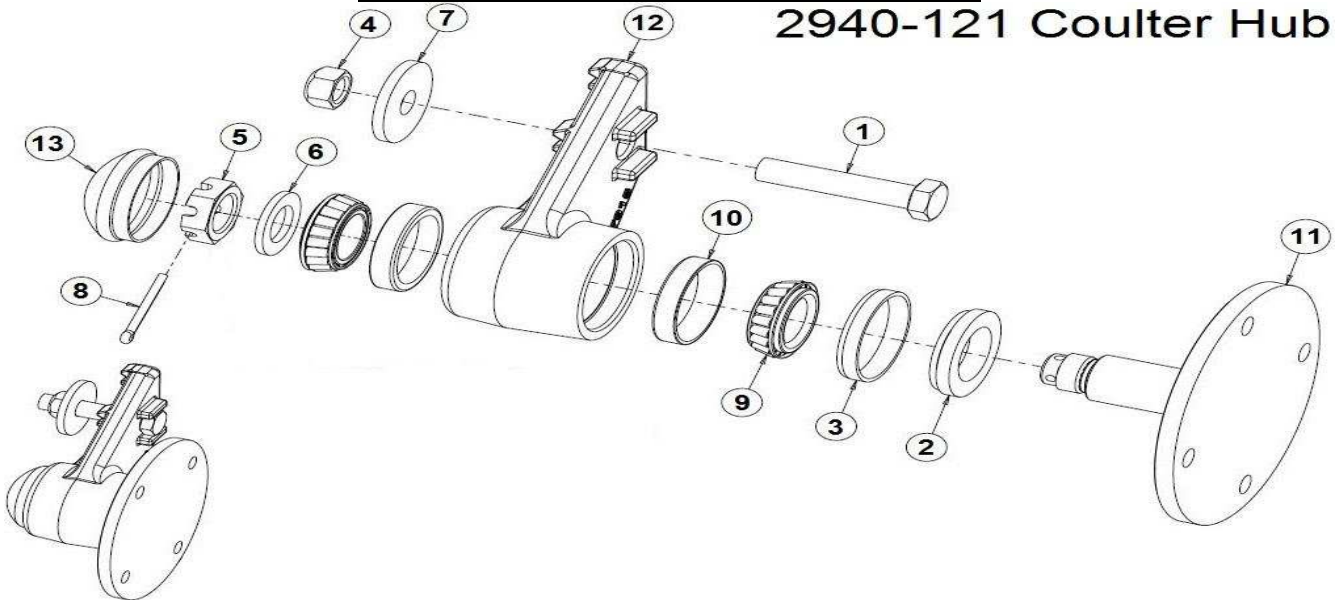

Item	Part Number	Description	Qty
1	2502-383	M16 X 2 X 80 HEX HEAD BOLT	1
2	2515-839	SEAL, COULTER	1
3	2515-840	SEAL, WHELL BEARING CUP	1
4	2520-475	M16 X 2 – 6H LOCK NUT CLASS 10.9 ZP	1
5	2520-569	1" – 14 CASTLE NUT	1
6	2526-581	M26 X 44 X 4 ROUND WASHER ZN	1
7	2526-583	SPECIAL FLAT WASHER	1
8	2531-177	M5 X 40 COTTER PIN ZP	1
9	2550-027-D	CONE, LM67010, KOYO	2
10	2550-029-D	CUP, LM67010, KOYO	2
11	2940-578	COULTER SPINDLE	1
12	2940-579	MACHINED HUB CASTING	1
13	6010-440	HUB CAP BLACK	

2940-082 5X7 & 7X7 BAR MOUNT KIT

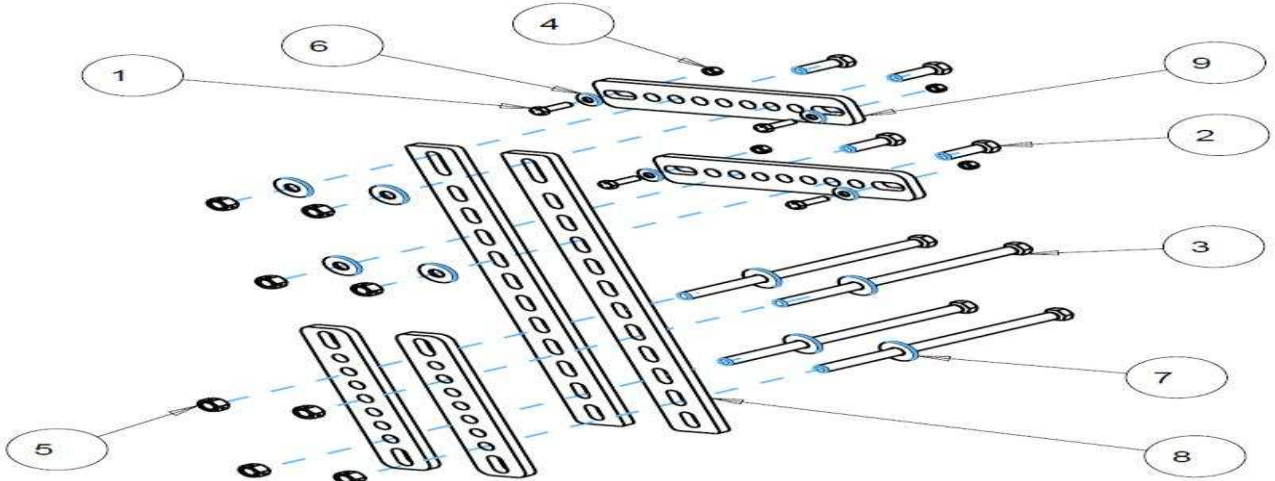

Item	Part Number	Description	Qty
1	2502-198	5/16-18 X 1 HHCS GR 5 ZP	4
2	2502-294	½-13 X 1-1/2 HHCS GR 5 ZP	4
3	2502-372	½-13 X 6 ½ HHCS GR5 ZP	4
	2502-374	½-13 X 9 HHCS GR 5 ZP	4
4	2520-205	5/16-18 LOCK HEX NUT ZP	4
5	2520-357	½-13 LOCK HEX NUT ZP	8
6	2526-201	5/16 STANDARD FLAT WASHER ZP	4
7	2526-351	½ STANDARD FLAT WASHER ZP	8
8	2940-344	MOUNT STRAP (LONG)	2
9	2940-355	MOUNT STRAP (SHORT)	4

PARTS IDENTIFICATION

2940-083
8X16 & 8X12 BAR MOUNT KIT

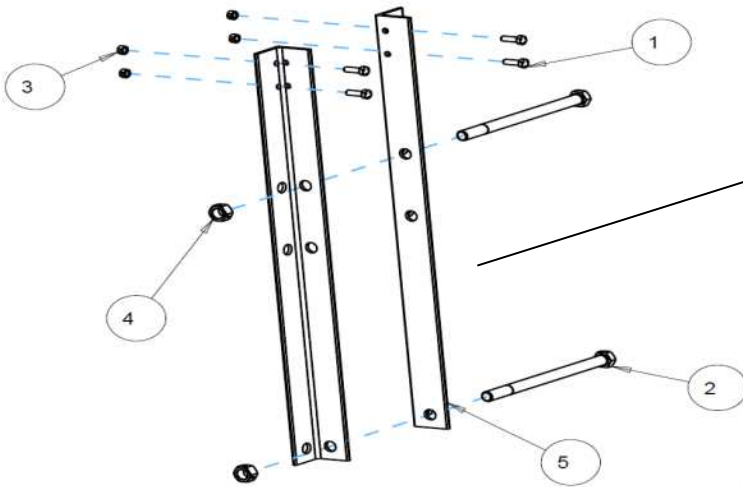

Item	Part Number	Description	Qty
1	2502-198	5/16-18 X 1 HHCS GR 5 ZP	4
2	2502-398	X 9 1/2 HHCS GR 5 ZP	2
3	2520-205	5/16-18 LOCK HEX NUT ZP	4
4	2520-459	5/8-11 LOCK HEX NUT ZP	2
5	2940-479	ANGLE MOUNT BRACKET	2

2940-084
UNIVERSAL HAND RAIL MOUNT KIT

Item	Part Number	Description	Qty
1	2502-198	5/16-18 X 1 HHCS GR 5 ZP	7
2	2502-207	5/16-18 X 2 HHCS GR 5 ZP	4
	2502-212	5/16-18 X 2 1/2 HHCS GR5 ZP	4
3	2520-205	5/16-18 LOCK HEX NUT ZP	11
4	2526-201	5/16 STANDARD FLAT WASHER ZP	18
5	2940-480	HAND RAIL TELESCOPING PLATE	2
6	2940-481	HAND RAIL CLAMP	2

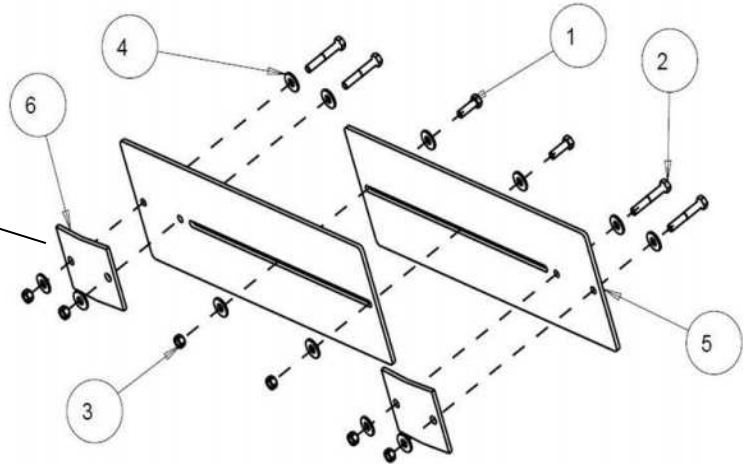

2940-085 2 PT/UNIVERSAL
COMPRESSOR MOUNT KIT

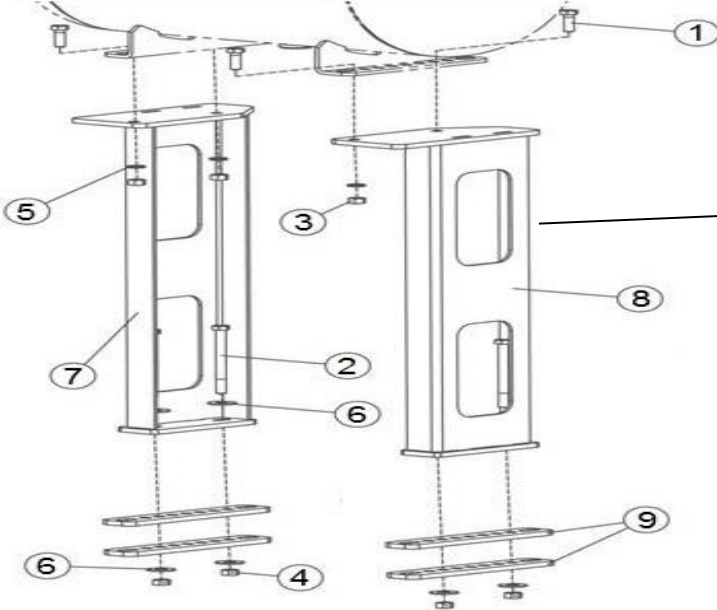

Item	Part #	Description	Qty
1	2502-294	1/2-13 X 1 1/2 HHCS GR 5 ZP	4
2	2502-373	1/2-13 X 6 HHCS GR 5 ZP	4
3	2520-352	1/2-13 HEX NUT ZP	4
4	2520-357	1/2-13 LOCK HEX NUT ZP	4
5	2525-352	1/2 MED LOCK WASHER ZP	4
6	2526-352	1/2 SAE FLAT WASHER ZP	8
7	2940-207	COMPRESSOR MOUNT W.A., LH	1
8	2940-208	COMPRESSOR MOUNT W.A., RH	1
9	2940-355	MOUNT STRAP	4

PARTS IDENTIFICATION

2940-086 DRAFT TUBE/UNIVERSAL COMPRESSOR MOUNT KIT

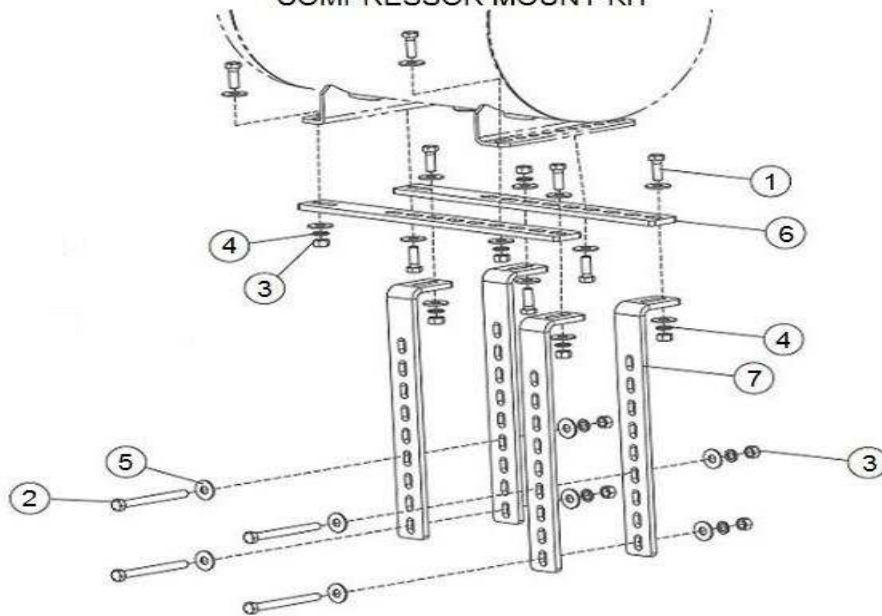

Item	Part Number	Description	Qty
1	2502-294	1/2-13 X 1 1/2 HHCS GR 5 ZP	8
2	2502-349	1/2-13 X 5 FLTHD HHCS GR 5 ZP	4
3	2520-352	1/2-13 HEX NUT ZP	12
4	2525-352	1/2 MED LOCK WASHER ZP	12
5	2526-351	1/2 STANDARD FLAT WASHER ZP	24
6	2940-344	COMPRESSOR STRAP	2
7	2940-351	COMPRESSOR MOUNT BRACKET	4

2940-090 8x12 & 2940-091 8x16 HYD COMP MOUNT KIT

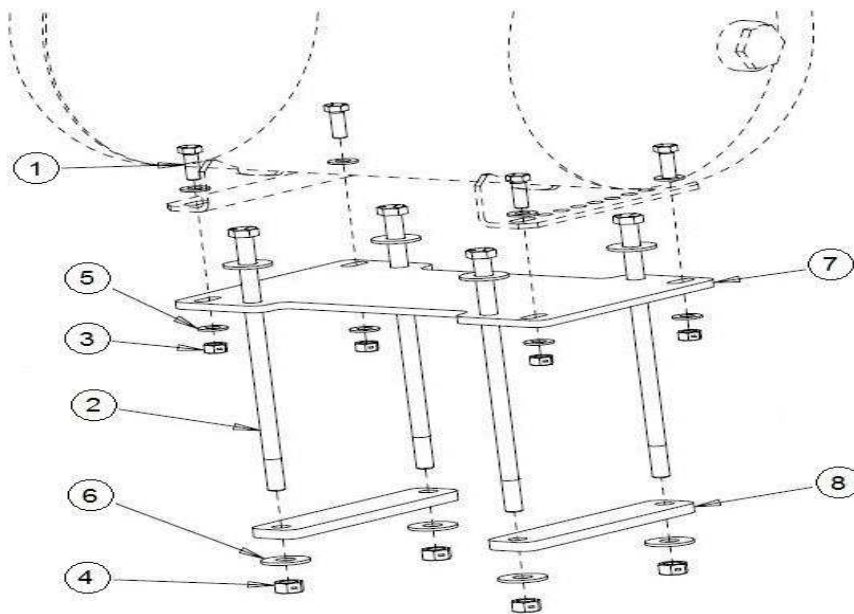

Item	Part Number	Description	Qty
1	2502-294	1/2-13 X 1 1/2 HHCS GR 5 ZP	4
2	2502-388	5/8-11 X 14 HHCS GR 5 ZP (IN THE 2940-090 KIT)	4
	2502-389	5/8-11 X 18 HHCS GR 5 ZP (IN THE 2940-091 KIT)	4
3	2520-357	1/2-13 HEX LOCK NUT ZP	4
4	2520-459	5/8-11 HEX LOCK NUT ZP	4
5	2526-352	1/2 STANDARD FLAT WASHER ZP	8
6	2526-451	5/8 STANDARD FLAT WASHER ZP	8
7	2940-372	HYDRAULIC COMPRESSOR MOUNT PLATE	1
8	2940-373	MOUNT STRAP	2

2940-106 HYD COMP PARTS IDENTIFICATION

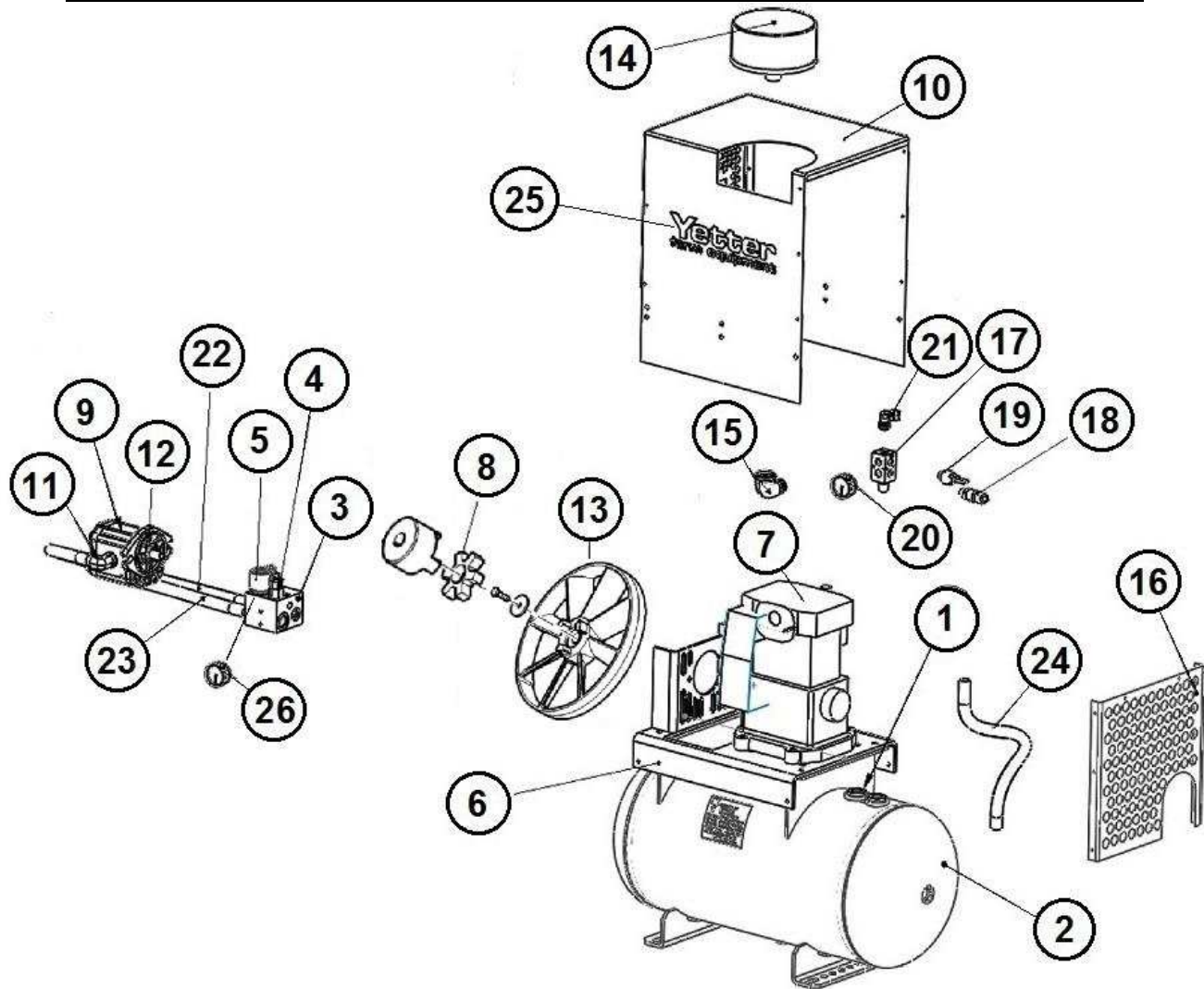

Item	Part Number	Description	Qty
1	N/A	CHECK VALVE	1
2	2940-440	12 GALLON TANK	1
3	2940-546	HYDRAULIC COMPRESSOR CONTROL BLOCK	1
4	N/A	FLOW CONTROL VALVE	1
5	2940-506	ON/OFF SOLENOID (COIL ONLY)	1
	2940-543	ON/OFF SOLENOID (CARTRIDGE VALVE)	1
6	N/A	FRAME	1
7	2940-545	ROL-AIR COMPRESSOR PUMP UNIT	1
8	2940-531	RUBBER SPIDER INSERT FOR LOVEJOY COUPLER	1
9	2940-554	HYDRAULIC MOTOR	1
10	N/A	HOUSING COVER	1
11	N/A	MOTOR ELBOW FITTING	1
12	N/A	INLET ELBOW FITTING	1
13	2940-519A	HYDRAULIC COMPRESSOR FAN, CAST (will fit on all Yetter Hyd. Compressors)	1
14	2940-549	HYDRAULIC COMPRESSOR AIR FILTER (FILTER ELEMENT ONLY)	1
15	N/A	FILTER ELBOW	1
16	N/A	BACK GUARD	1
17	N/A	AIR MANIFOLD	1
18	2940-416	175PSI TANK SAFETY RELIEF VALVE	1
19	2940-377	COMPRESSOR PRESSURE SWITCH 125-145PSI	1
20	2940-439	0-160PSI HYDRAULIC COMPRESSOR GAUGE	1
21	2940-635	3/8PTC X 3/8 NPT 90 DEGREE ELBOW FITTING, SWIVEL	1
22	N/A	TANK HOSE	1
23	N/A	INLET HOSE	1
24	N/A	PRESSURE LINE	1
25	2565-058	YETTER DECAL	1
26	2940-544	HYDRAULIC PRESSURE GAUGE WITH ADAPTER 0 – 5000PSI (LIQUID FILLED)	1

HYDRAULIC PUMP (2940-545) PARTS IDENTIFICATION

ROLAIR
SCHEMATIC FOR
PMP12MK103

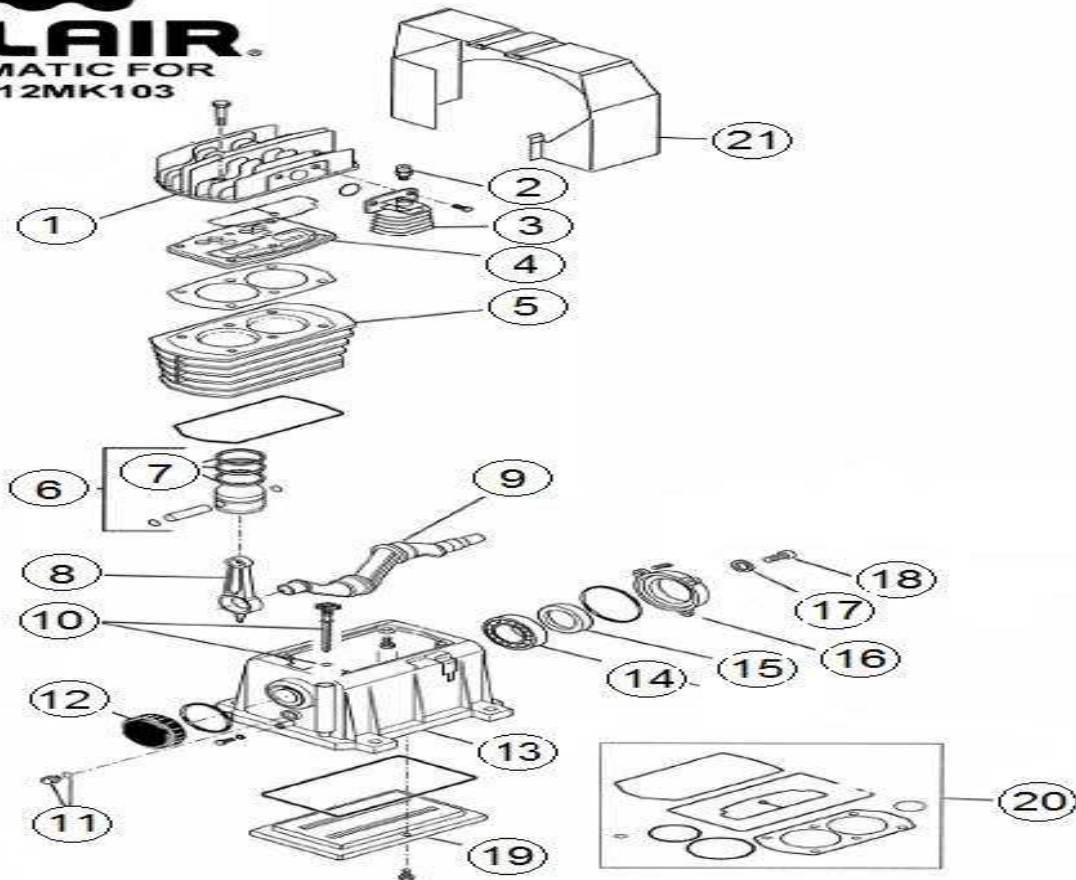

ROLAIR
S Y S T E M S

PARTS LIST FOR PMP12MK103

Schematic #	Description	Part #	Qty.
1	Head	FC113167020	1
2	Cold Start Valve	FC011158000	1
3	Aftercooler	FC116091024	1
4	Valve Plate Assembly	FC413167005	1
5	Cylinder	FC113167002	1
6	Complete Piston Assembly	FC413167006	2
7	Ring Set (2 required)	FC213167001	2
8	Connecting Rod	FC113150004	2
9	Crankshaft	FC113167003	1
10	Dipstick	FC312036000	1
11	Sight Gauge	FC012029000	1
12	End Cover	FC113149009	1
13	Crankcase	FC113167001	1
14	Ball Bearing	FC033027000	1
15	Oil Seal	FC010053000	1
16	Bearing Carrier	FC113149008	1
17	Washer	FC014005001	1
18	Bolt (Left-Hand Thread)	FC014001057	1
19	Lower Cover	FC113149015	1
20	Gasket Set	FC213167002	1
21	Shroud	FC113150002	1

PART REFERENCE ONLY

2940-103A PARTS IDENTIFICATION

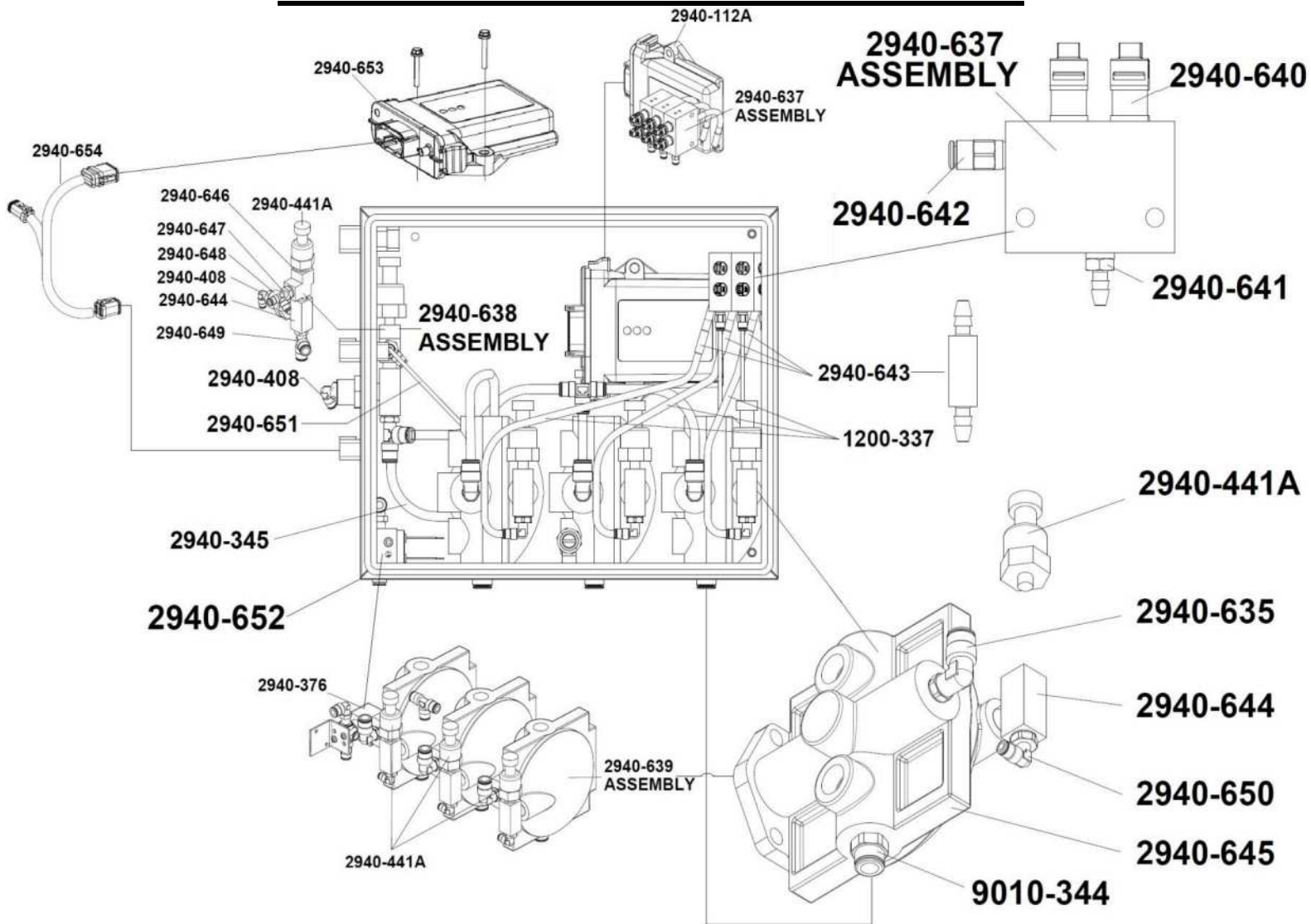

PART #	DESCRIPTION	QTY
1200-337	1/4 TUBING, 100FT ROLL, BLACK	1
2940-112A	12V MIDAC VDM	1
2940-345	3/8 TUBING, 100FT ROLL, BLACK	1
2940-376	WATER SEPARATOR DRAIN VALVE	1
2940-408	3/8PTC X 1/4NPT 90° ELBOW FITTING	1
2940-441A	0-200PSI PRESSURE TRANSDUCER W/ DEUTSCH	4
2940-635	3/8"PTC X 3/8NPT 90° ELBOW FITTING	3
2940-637	VALVE BLOCK ASSEMBLY	3
2940-638	INLET ASSEMBLY	1
2940-639	POR ASSEMBLY	3
2940-640	MAC BV VLAVE 2 WAY	6
2940-641	10-32 TO 1/4" TUBE BARB FITTING	3
2940-642	10-32 TO 1/4" TUBE PTC FITTING	3
2940-643	1/4" TUBE ORIFICE	3
2940-644	1/4" NPT TEE	4
2940-645	PILOT OPERATED REGULATOR	3
2940-646	1/4" NPT STREET ELBOW	1
2940-647	1/4"NPT TO 5/32" RUN TEE	1
2940-648	1/4" NPT BULKHEAD	1
2940-649	1/4NPT 3/8" RUN TEE	1
2940-650	1/4NPT TO 1/4" TUBE PTC ELBOW FITTING	3
2940-651	5/32 TUBING, BLACK	1
2940-652	12 X 14 X 8 ENCLOSURE	1
2940-653	THRASHER MODULE	1
2940-654	THRASHER TO MIDAC CONTROL HARNESS	1
9010-344	3/8PTC X 3/8NPTF STRAIGHT FITTING	3

2940-101A PARTS IDENTIFICATION

Item	Part #	Description	Qty
1	2940-416	175PSI TANK SAFETY RELIEF VALVE	1
2	2940-439	0-160PSI HYDRAULIC COMPRESSOR GAUGE	1
3	N/A	AIR MANIFOLD	1
4	2940-635	3/8PC X 3/8NPT 90° ELBOW FITTING, SWIVEL	1
5	2940-336	HIGH PRESSURE RELIEF VALVE (NO FITTINGS)	1
	1200-323	1/4"PC TO 1/8NPT ELBOW	
6	2940-377	COMPRESSOR PRESSURE SWITCH 125-145PSI	1
7	2940-395	FILTER ELEMENT	1
8	2940-390	ELECTRIC COMPRESSOR	1
9	2940-391	COMPRESSOR RELAY	1
10	N/A	12 GALLON TANK	1
11	N/A	1/4 TURN TANK DRAIN VALVE	1

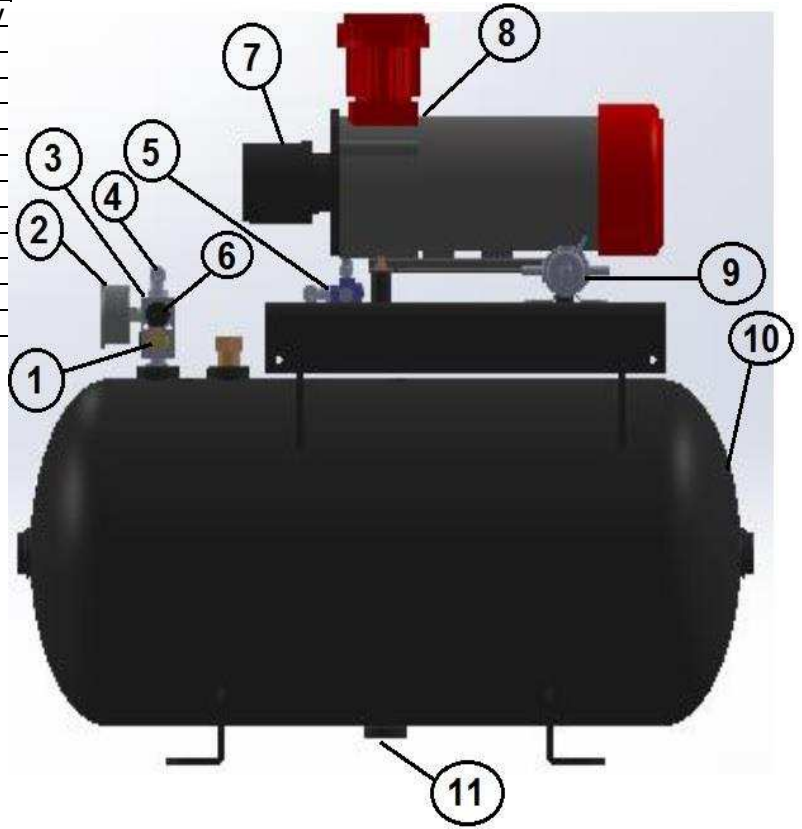

2940-415 PARTS IDENTIFICATION

Item	Part #	Description	Qty
1	N/A	SCREW, SEPARATOR TO MOUNTING BRACKET	2
2	N/A	SCREW, WATER SEPARATOR TO REGULATOR	2
3	N/A	MOUNTING BRACKET	1
4	2940-404	REGULATOR	1
5	2940-408	3/8PTC X 1/4NPT ELBOW AIR FITTING	2
6	2940-423	1/4PTC X 1/8NPT ELBOW AIR FITTING	1
7	2940-438	WATER SEPARATOR	1
8	2940-667	PRESSURE GAUGE, 0-160PSI, 1/8NPT	1

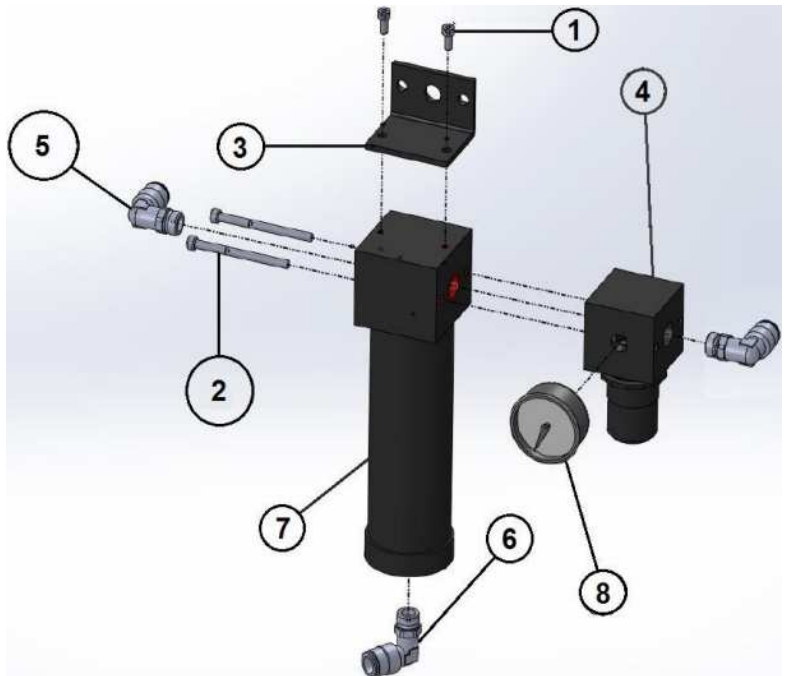

Troubleshooting Guide

Problem	Cause	Corrective Action
Tank pressure drops when compressor shuts off	<ol style="list-style-type: none"> 1. improper check valve function 2. loose connections/ air leak 3. water separator drain valve leaking 	<ol style="list-style-type: none"> 1. replace check valve on compressor 2. perform leak check (see pages 53 & 54) 3. replace water separator valve or valve is plumbed backwards, switch ¼ airlines on control box
Compressor runs continuously/air flow lower than normal, Compressor Run Time High warning on cab controller if compressor runs continuously for 15 minutes	<ol style="list-style-type: none"> 1. excessive air usage 2. loose connections/air leak 3. Improper pressure switch function 4. clogged air filter element 5. worn compressor 6. defective safety valve 7. tank drain valve open 8. water separator valve leaking 	<ol style="list-style-type: none"> 1. decrease air usage 2. perform leak check (see pages 53 & 54) 3. replace pressure switch 4. clean/replace filter element 5. replace compressor 6. replace safety valve 7. close tank drain valve 8. replace water separator valve or valve is plumbed backwards, switch ¼ airlines on control box
Compressor will not run	<ol style="list-style-type: none"> 1. air system is off 2. hydraulics disengaged 3. no power to control box 4. communication harness connection issue 5. shut off psi(145psi) reached 6. worn compressor 7. Improper pressure switch function 	<ol style="list-style-type: none"> 1. press ACTIVATE SYSTEM 2. engage compressor hydraulic circuit 3. check power connections from battery to control box, check 2940-166 breaker at battery 4. check harnesses from compressor to control box 5. compressor will restart after tank pressure drops below 125psi 6. replace compressor 7. replace pressure switch
No air output from the RU, RD, and WT ports even though pressure is commanded and tank pressure reads 75psi or greater	<ol style="list-style-type: none"> 1. air system is off 2. no power to the VDM 3. 75psi of tank pressure not achieved 4. improperly functioning Mac Valves 5. communication harness connection issue 	<ol style="list-style-type: none"> 1. press ACTIVATE SYSTEM 2. check power connections from battery to VDM, check 2940-166 breaker at the battery 3. allow the compressor to build at least 75psi 4. replace Mac Valves as needed 5. check the end of all connectors to make sure terminal pins are all flush to the end of the male connectors and the connectors are seated tightly
Low or sporadic tank pressure reading Air leaking out regulator knob	water separator/regulator assembly plumbed incorrectly	plumb water separator/regulator correctly (air compressor→water separator→exit regulator side→enter control box inlet port)
Compressor struggles to build/won't build 145psi	flow control valve adjustment needed	flow control valve adjustment needed (see page 53 for instructions)
No connection to Thrasher or No connection between VDM & Thrasher	improper communication harness connection between VDM and Thrasher Thrasher needs to be closer or more visible to table	<ol style="list-style-type: none"> 1. Make sure lights on Thrasher are illuminated, Operating Status solid green, Status 1 will rapid flash red, Status 2 light is on if using ISOBUS 2. Make sure 2940-654 Thrasher to Midac is plugged in 3. Purchase 2940-677 15ft ext. harness
ISOBUS won't communicate	1. Communication Error	1. Remove 2940-660 Resister Harness from 2940-655 ISOBUS Control Harness
Excessive noise from compressor	<ol style="list-style-type: none"> 1. loose mounting bolts 2. worn bearings 3. cylinder or piston is worn 4. compressor over speeding 	<ol style="list-style-type: none"> 1. tighten bolts 2. replace compressor 3. rebuild compressor 4. check compressor RPMs (see page 53) & slow motor down if needed, hydraulic plumbing of the compressor is incorrect (see page 28 - 29)
Excessive moisture in discharge	<ol style="list-style-type: none"> 1. excessive water in air tank 2. high humidity 	<ol style="list-style-type: none"> 1. drain tank, drain tank more frequently 2. move compressor to area with less humidity.
Hydraulic motor front seal leakage	<ol style="list-style-type: none"> 1. case drain clogged or unplugged 2. case drain not plumbed correctly 	<ol style="list-style-type: none"> 1. remove case drain plumbing and clean out debris/obstruction, replace seal 2. Plumb case drain according to the instructions (see pages 30), replace seal
Row cleaners do not react uniformly	1. check each row cleaner for drag	1. replace bushings/parts causing drag or check hardware tightness

NOTES



A Tradition of Solutions since 1930

Yetter Farm Equipment Co

PO BOX 358 109 S. McDonough

Colchester, IL 62326-0358

Phone: 309-776-4111

Toll Free: 800-447-5777

Email: info@yetterco.com

For updated models and manuals visit the Yetter website:

www.yetterco.com

© Yetter Farm Equipment Co. All Rights Reserved

2565-983_REV_C • 02/23