



**2920 SERIES  
MAX SEALER PLUS™  
OPERATOR'S MANUAL  
PARTS IDENTIFICATION  
2565-727\_REV\_C • 09/2023**



**YETTER MANUFACTURING CO.**  
*FOUNDED 1930*

Colchester, IL 62326-0358  
Toll free: 800/447-5777  
309/776-3222 (Fax)  
Website: [www.yetterco.com](http://www.yetterco.com)  
E-mail: [info@yetterco.com](mailto:info@yetterco.com)

**YETTER**

## FOREWORD

You've just joined an exclusive but rapidly growing club.

For our part, we want to welcome you to the group and thank you for buying a Yetter product.

We hope your new Yetter products will help you achieve both goals-increase your productivity and increase your efficiency so that you may generate more profit.

This operator's manual has been designed into four major sections: Foreword, Safety Precautions, Installation Instructions and Parts Breakdown.



This **SAFETY ALERT SYMBOL** indicates important safety messages in the manual. When you see this symbol, be alert to the possibility of **PERSONAL INJURY** and carefully read the message that follows.

The word **NOTE** is used to convey information that is out of context with the manual text. It contains special information such as specifications, techniques and reference information of a supplementary nature.

The word **IMPORTANT** is used in the text when immediate damage will occur to the machine due

to improper technique or operation. Important will apply to the same information as specified by note only of an immediate and urgent nature.

It is the responsibility of the user to read the operator's manual and comply with the safe and correct operating procedure and to lubricate and maintain the product according to the maintenance schedule in the operator's manual.

The user is responsible for inspecting his machine and for having parts repaired or replaced when continued use of the product would cause damage or excessive wear to the other parts.

It is the user's responsibility to deliver his machine to the Yetter dealer who sold him the product for service or replacement of defective parts, which are covered by the warranty policy.

If you are unable to understand or follow the instructions provided in this publication, consult your local Yetter dealer or contact:

### **YETTER MANUFACTURING CO.**

309/776-4111

800/447-5777

309/776-3222 (FAX)

Website: [www.yetterco.com](http://www.yetterco.com)

E-mail: [info@yetterco.com](mailto:info@yetterco.com)

## WARRANTY

Yetter Manufacturing warrants all products manufactured and sold by it against defects in material. This warranty being expressly limited to replacement at the factory of such parts or products as shall appear to be defective after inspection. This warranty does not obligate the Company to bear cost of labor in replacement of parts. It is the policy of the Company to make improvements without incurring obligations to add them to any unit already sold. No warranty is made or authorized to be made, other than herein set forth. This warranty is in effect for one year after purchase.

Dealer \_\_\_\_\_

**Yetter Manufacturing warrants its own products only and cannot be responsible for damages to equipment on which mounted.**

## SAFETY PRECAUTIONS

You can make your farm a safer place to live and work if you observe the safety precautions given. Study these precautions carefully and insist those working with you and for you follow the precautions.

Finally, remember this an accident is usually caused by someone's carelessness, neglect or oversight.

**A brief description of signal words that may be used in this manual:**

**CAUTION:** Used as a general reminder of good safety practices or to direct attention to unsafe practices.

**WARNING:** Denotes a specific potential hazard.

**DANGER:** Denotes the most serious specific potential hazard.



### CAUTION

Consult your implement and tractor operator's manual for correct and safe operating practices. Be aware of towed implement width and allow safe clearance.



### CAUTION: SAFETY SIGNS

Safety decals are placed on the implement to alert the operator and others to the risk of personal injury or unsafe operation during normal operations and servicing.

1. The safety decals must be kept clean and in good condition to ensure that they are legible.
2. Safety decals must be replaced if they are missing or illegible.
3. When components are replaced during repair or servicing, check that the new components include the necessary safety signs.
4. Replacement safety decals may be obtained from your local dealer.



### WARNING

Read these instructions carefully to acquaint yourself with the Equipment. Working with unfamiliar equipment can lead to accidents.

Never park the equipment on a steep incline or leave the equipment running unattended.

Never clean, lubricate or adjust a machine that is in motion.

Always check that straps are secure.

Make sure latches are in pinned position when moving equipment.

Do not allow children to operate this equipment.

Do not allow riders on the equipment, trailer and/or pick-up.

Use speed and caution dictated by the terrain being traversed. Do not operate on any slope steep enough to cause tipping or loss of control.

Read and understand the operator's manual and require all other persons who will operate the equipment to do the same.

If operating on public roadways, where legal, be certain all lighting is operating properly and observe all traffic laws.

Beware of increased stopping distances and control effort when operating with implements attached.

Be familiar with all controls and be prepared to stop equipment quickly in an emergency.

**FAILURE TO HEED MAY RESULT IN PERSONAL INJURY OR DEATH.**

# INTRODUCTION

The 2920 MAX SEALER PLUS™ disc sealer has been designed for the operators who demand durability, longevity and performance in the field. The 2920 MAX SEALER PLUS™ has adjustable blade pitch to match the changes in soil tilth. The unit is heavy enough to fill the knife track and flexible enough to not cut a trench for water to start erosion. The 2920 MAX SEALER PLUS™ has independent arms to allow the blades to follow the roughest terrain and maintain soil flow to cover the knife track. Because each blade is independent the sealer can handle field conditions that have large amounts of crop residue, which keeps the toolbar productive even in less than ideal conditions.

## MODELS

The 2920 MAX SEALER PLUS™ is available in two models with three-blade style to choose from.

### “C” SHANK MODELS

2920-051 – 18” NOTCHED BLADE  
2920-052 – 18” SMOOTH BLADE  
2920-053 – 13” SHARKTOOTH

Applications include:   1” x 2” flat shank  
                                  1-1/4” square  
                                  2” edge bent shank  
                                  1-1/4” coil shank

### UNIVERSAL MODELS

2920-054 – 13” SHARKTOOTH BLADE  
2920-055 – 18” NOTCHED BLADE  
2920-056 – 18” SMOOTH BLADE

Applications include:   YETTER MAVERICK II  
                                  YETTER AVENGER  
                                  DIETRICH SLURRY INJECTOR

The 2920 MAX SEALER PLUS™ will not work with shanks that use “clamp on” style knife plates and 1” x 3” straight shanks.



**CAUTION:** Frozen soil or rocks may cause damage to the 2920 MAX SEALER PLUS™.

# GENERAL INFORMATION



Note: Right Hand and Left Hand designations are based on sitting in the tractor and facing forward.

## BOLT TORQUE

### READ THESE INSTRUCTIONS FIRST:

1. Improperly tightened bolts will result in damage, breakage, expense, and down time.
2. Always replace bolts with the specified grade and type.
3. Torque properly before first use of the machine and every 2-4 hours of use until you are sure bolts are staying tight.
4. The chart below is a guide for proper torque. Use it unless a specified torque is called out elsewhere in the manual.
5. Torque is the force you apply to the wrench handle or the cheater bar, times the length of the handle or bar.
6. Use a torque wrench whenever possible.

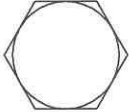
The following table shows torque in ft. lbs.

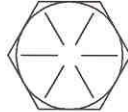
BOLT DIA. AND THREADS PER INCH	 GRADE 2	 OR  GRADE 5 A-325	 GRADE 8
3/8-16	25	35	50
7/16-14	35	55	80
1/2-13	55	85	125
9/16-12	75	125	175
5/8-11	105	170	235
3/4-10	185	305	425
7/8-9	170	445	690
1-8	260	670	1030
1 1/8-7	365	900	1460
1 1/4-7	515	1275	2060
1 3/8-6	675	1675	2700
1 1/2-6	900	2150	3500
1 3/4-5	1410	3500	5600

Lubricate all bearings and moving parts as assembled and make certain that they work freely.



**WARNING:** Never work around the toolbar / implement while in a raised position without using safety lockups.



**CAUTION:** The 2920 MAX SEALER PLUS™ unit has sharp blades. Extra attention should be paid to lifting techniques while handling and or maneuvering the units during assembly. Failure to do so may lead to personal injury. Use heavy gloves while handling the blades during assembly and any time adjustments or maintenance operations are made to the units.

# ASSEMBLY

**STEP 1.** Attach the 2920-115 swing arm assembly to the shank/bracket using the appropriate u-bolts, flat washers, lock washers and hex nuts or the 1/2" bolts and lock nuts.

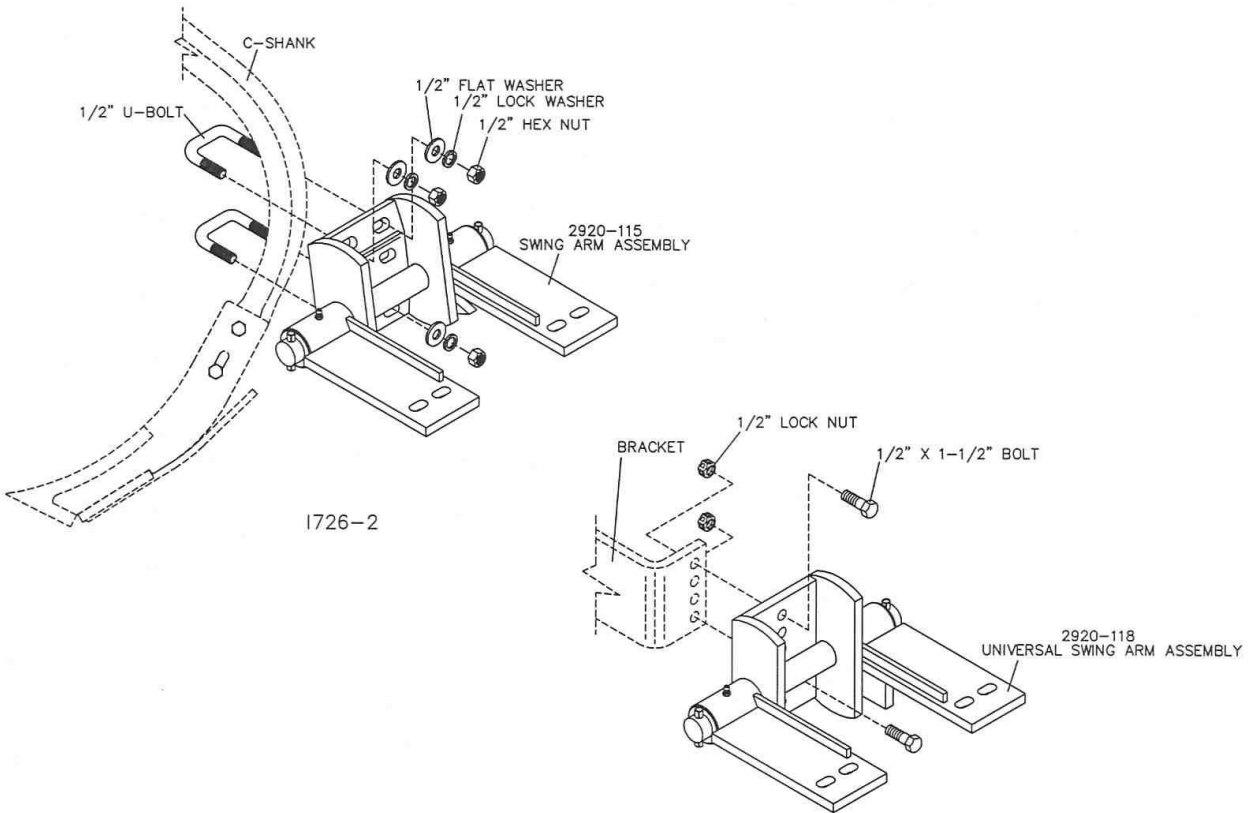

**STEP 2.** Attach the 2920-117 Arm Hub Assembly to the 2920-115 Swing Arm using the 1/2" carriage bolts, flat washers, lock washers and hex nuts.

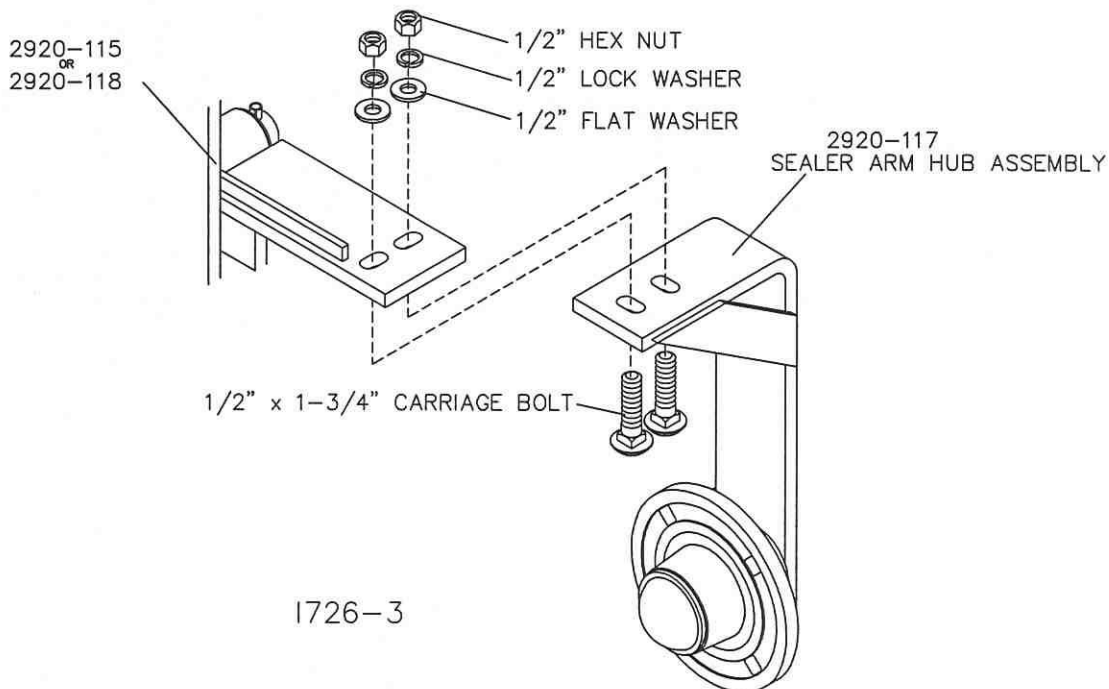

# ASSEMBLY

**STEP 3.** Attach the blade to the 2920-117 Sealer Arm Hub Assembly using the 4) 1/2" x 1-1/2" carriage bolts, lock washers and hex nuts. Curved blades can be used with the cup "in" toward the knife for the most aggressive adjustment or with the cup "out" away from the knife for a less aggressive adjustment.

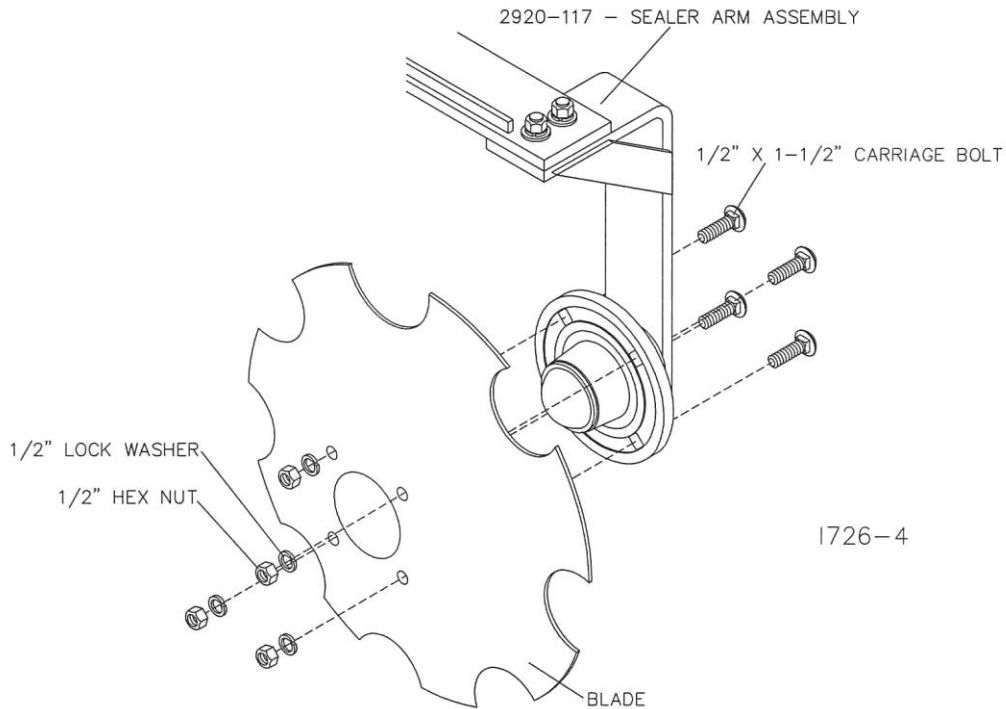

**STEP 4.** "Barn Yard Setting" – set the sealer blade to 2" closer to the bottom of the knife than the depth that the knife will be used at. Example: knife at 6" depth, set the blades to 4" above the bottom of the knife. Adjust the blade pitch as needed to cover the knife track with soil. Tighten all hardware to the recommended amount of torque unless otherwise stated.

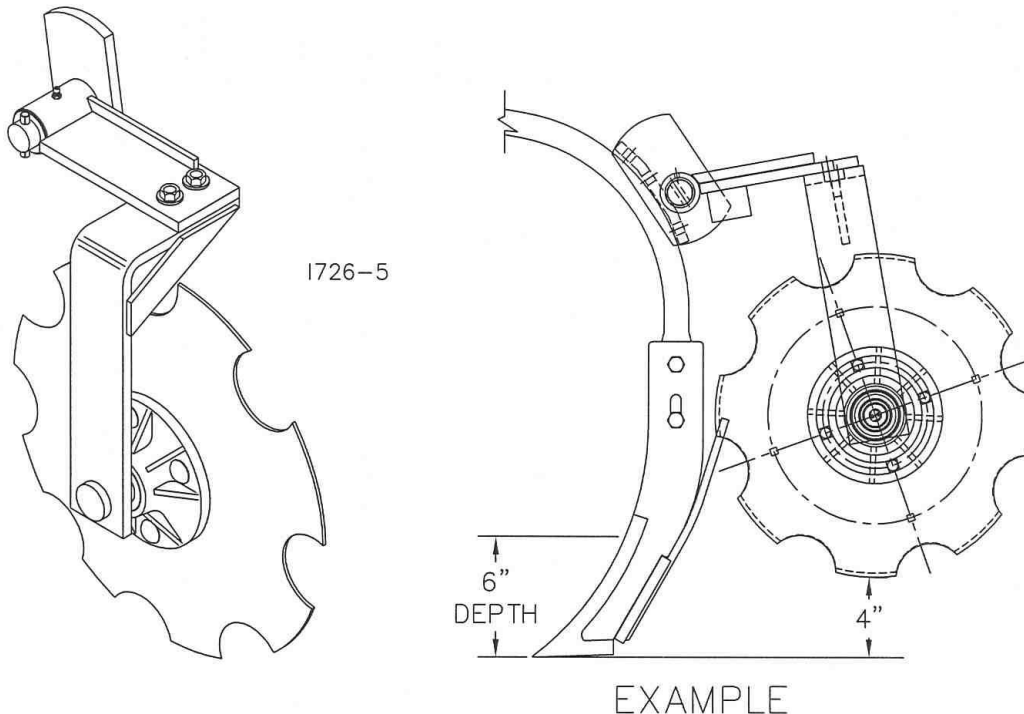

# MAINTENANCE

Lubrication: Use #2 multi-purpose lithium grease.

To insure longevity and reliability of the MAX SEALER PLUS™ the recommended lubrication schedule should be followed.

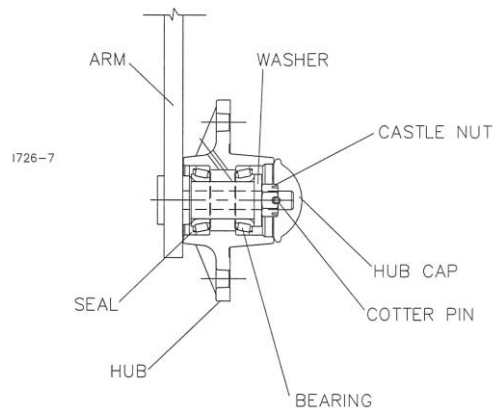
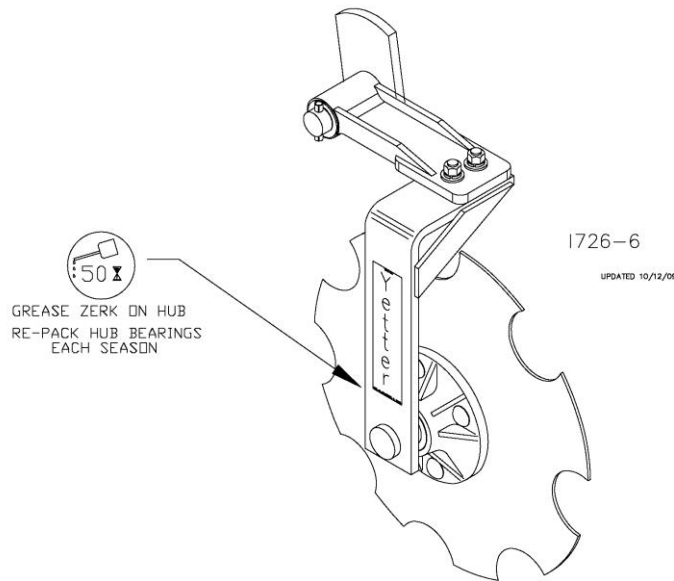

## BEARING ADJUSTMENT

Tighten the slotted nut to 10 to 15 ft/lbs. or until a definite drag is felt when the blade is turned by hand. Tighten the nut one slot position to align the slot with the hole in the spindle shaft. Secure the nut with a new cotter pin. Install the hubcap.

## BEARING REPLACEMENT

1. Raise the toolbar until the blade is clear of the ground. Place a safety stand under the toolbar. Remove the blade from the hub assembly. Remove the hubcap, cotter pin, slotted nut and washer from the hub assembly.
2. Remove bearing cones and seal from the hub.
3. Wash the old grease from the hub, bearing cups, spindle, seals and bearing cones. Inspect the condition of bearing cups, cones and seals. Replace if necessary.
4. Apply #2 multi-purpose lithium grease on each bearing. Make sure the space around each roller is filled. Lubricate the bearing cups.
5. Position the bearing in the cup and install the seal. Lubricate the seal lips and proceed with re-assembly of the removed parts including the blade. Blade bolt torque is 90 to 96 ft/lbs.
6. Tighten the slotted nut to 10 to 15 ft/lbs. or until a definite drag is felt when blade is turned by hand. Tighten the nut one slot position to line up the cotter pin hole with a slot. Secure the nut with a new cotter pin. Install the hubcap.



# PARTS IDENTIFICATION

- 2920-051 – MAX SEALER PLUS, 18 NOTCH
- 2920-052 – MAX SEALER PLUS, 18 SMOOTH
- 2920-053 – MAX SEALER PLUS, SHARKTOOTH

DET	QTY	PART NO.	DESCRIPTION
1	2	2570-068	1/2 X 2 X 2-1/4 U-BOLT ZYD
	2	2570-589	1/2 X 1-1/4 X 2-1/2 U-BOLT ZYD
	2	2570-773	1/2 X 1-1/4 X 3-1/4 U-BOLT ZYD
2	16	2525-352	1/2 MED LOCKWASHER ZP
3	16	2520-352	1/2-13 HEX NUT ZP
4	1	2920-115	SWING ARMS ASS'Y
5	8	2505-339	1/2-13 X 1-1/2 CAR BLT GR.5 ZP.
6	8	2526-352	1/2 SAE FLATWASHER ZP
7	2	2920-117	SEALER ARM HUB ASS'Y
8	4	2505-344	1/2-13 X 1-3/4 CAR BLT GR 5 ZP
9	2	2571-182	.157 X 18 NOTCHED DISC BLADE
9A	2	2571-183	.157 X 18 SMOOTH DISC BLADE
9B	2	2920-352	13" SHARKTOOTH WHEEL (5.25" B.C.)
10	2	2987-301	HUB CAP RETAINER-(OPTIONAL)

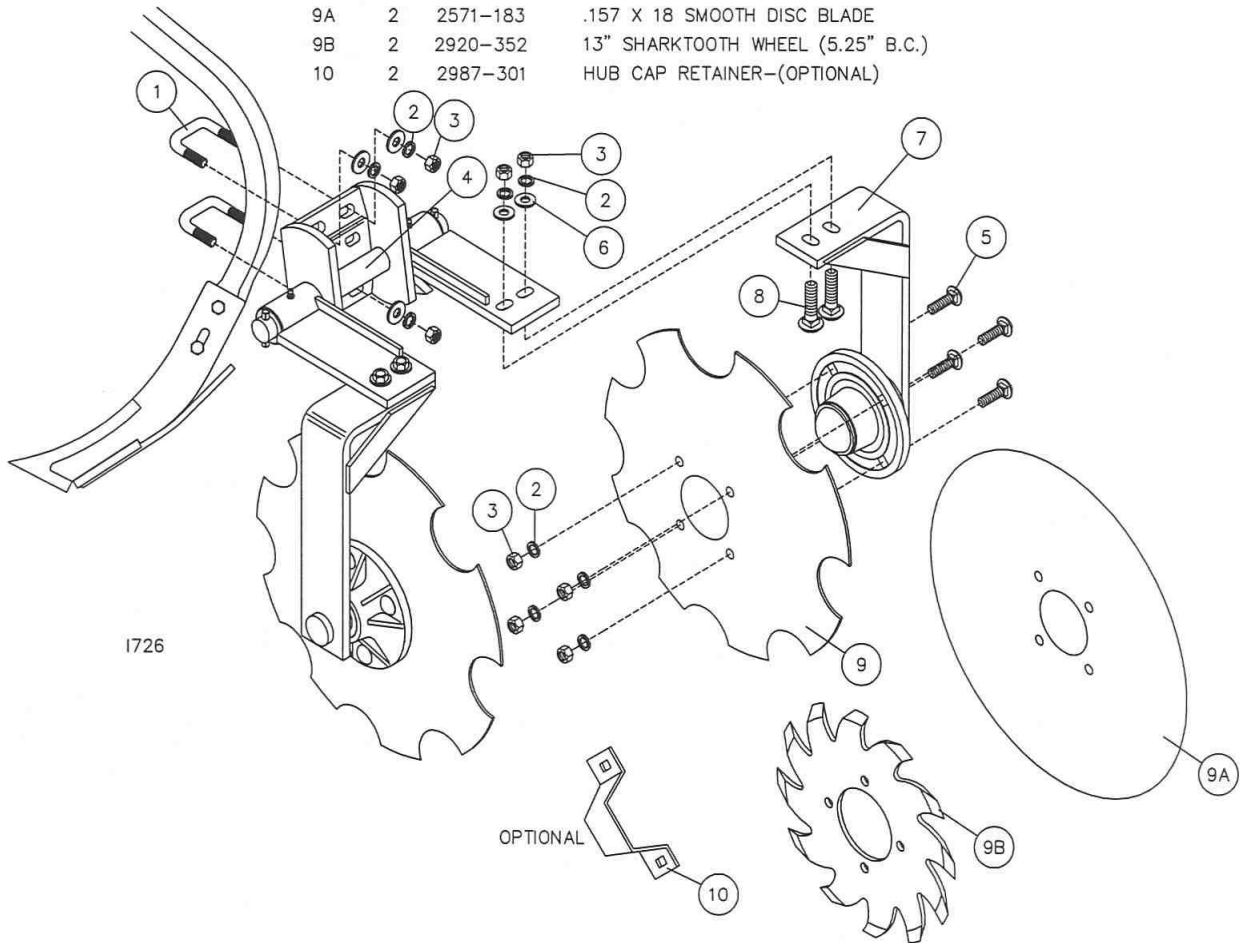

# PARTS IDENTIFICATION

2920-054 – MAX SEALER, SHARKTOOTH, UNIVERSAL

2920-055 – MAX SEALER, 18 NOTCH, UNIVERSAL

2920-056 – MAX SEALER, 18 SMOOTH, UNIVERSAL

DET	QTY	PART NO.	DESCRIPTION
1	12	2525-352	1/2 MED LOCKWASHER ZP
2	12	2520-352	1/2-13 HEX NUT ZP
3	1	2920-118	SWING ARMS ASS'Y, UNIVERSAL
4	8	2505-339	1/2-13 X 1-1/2 CAR BLT GR.5 ZP.
5	4	2526-352	1/2 SAE FLATWASHER ZYD
6	2	2920-117	SEALER ARM HUB ASS'Y
7	4	2505-344	1/2-13 X 1-3/4 CAR BLT GR 5 ZP
8	2	2571-182	.157 X 18 NOTCHED DISC BLADE
8A	2	2571-183	.157 X 18 SMOOTH DISC BLADE
8B	2	2920-352	13" SHARK TOOTH WHEEL (5.25" B.C.)
9	2	2502-294	1/2-13 X 1-1/2 HHCS GR. 5 ZP
10	2	2520-357	1/2-13 LOCK HEX NUT ZP
11	2	2987-301	HUB CAP RETAINER-(OPTIONAL)

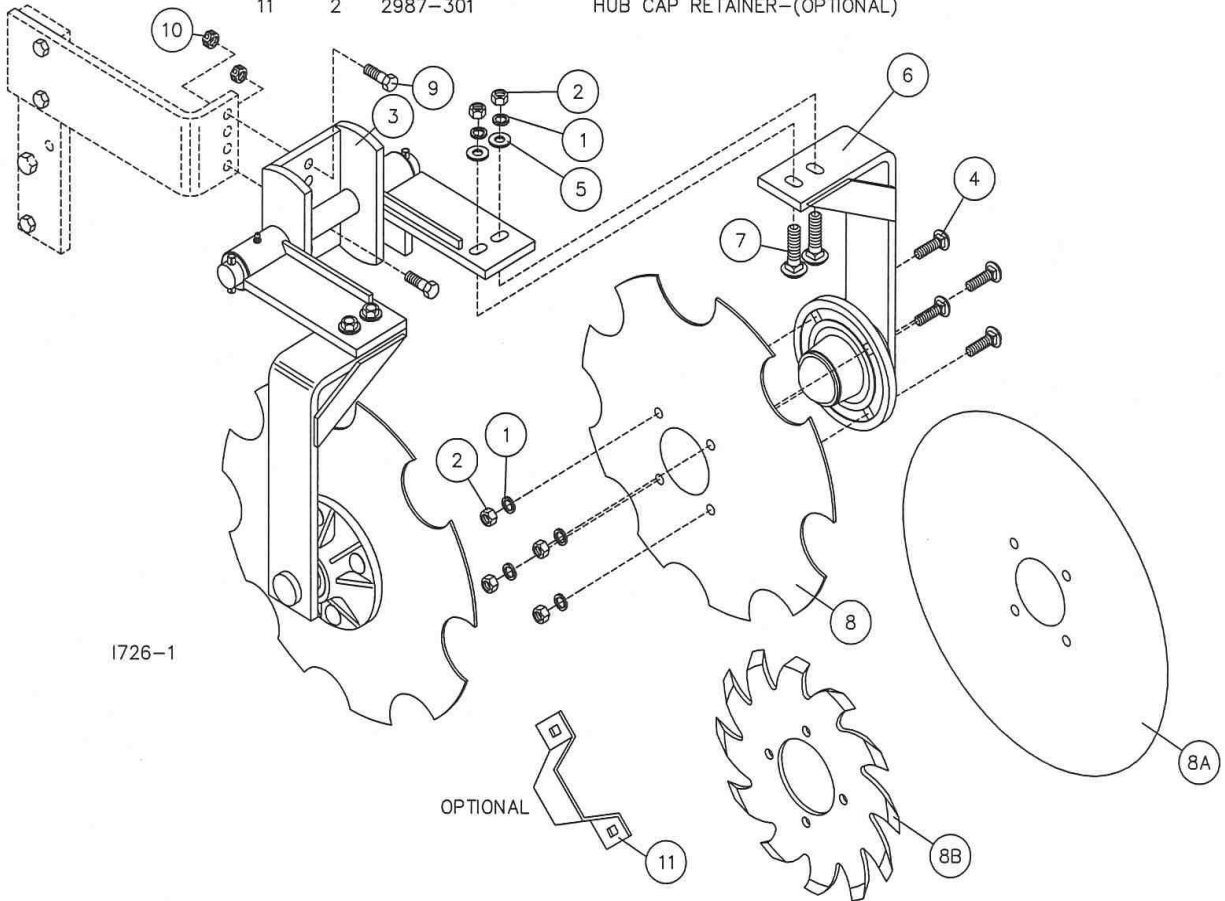

# PARTS IDENTIFICATION

## 2920-115 C-SHANK MODEL

DET	QTY	PART NO.	DESCRIPTION
1	2	2526-561	1-17/64ID X1-7/60D X146A MB BL
2	2	2530-212	3/8 X 2 ROLL PIN ZP
3	1	2920-218	SEALER MOUNT W.A.
4	1	2920-217	L.H. SWNG ARM W.A.
	1	2528-364	1.25IDX1.50DX3 GAR-MAX BEARING
5	1	2920-218	R.H. SWNG ARM W.A.
	1	2528-364	1.25IDX1.50DX3 GAR-MAX BEARING

1726-12

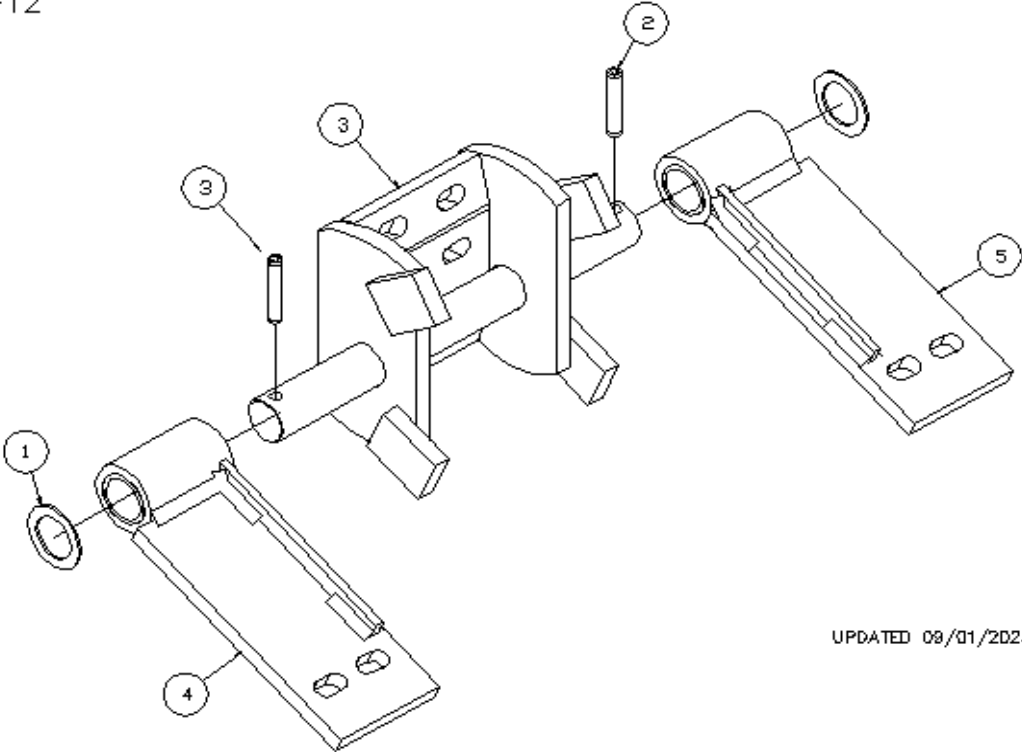

UPDATED 09/01/2023

# PARTS IDENTIFICATION

## 2920-118 UNIVERSAL MODEL

DET	QTY	PART NO.	DESCRIPTION
1	2	2526-561	1-17/64ID X1-7/8OD X14GA MB BL
2	2	2530-212	3/8 X 2 ROLL PIN ZP
3	1	2920-217	L.H. SWNG ARM W.A.
	1	2528-364	1.25IDX1.50DX3 GAR-MAX BEARING
4	1	2920-218	R.H. SWNG ARM W.A.
	1	2528-364	1.25IDX1.50DX3 GAR-MAX BEARING
5	1	2920-219	SEALER MOUNT W.A., DIETRICH

1726-11

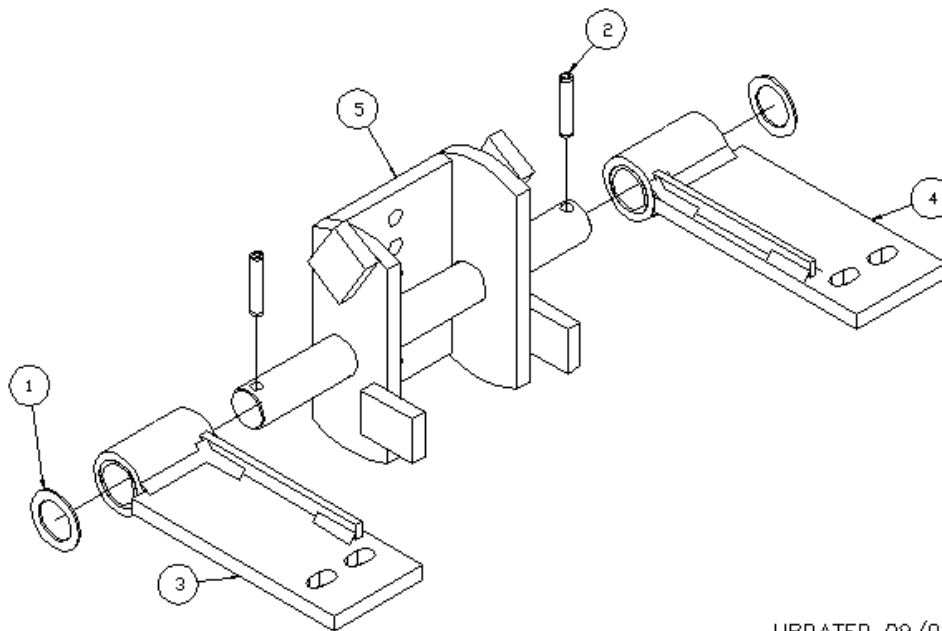

UPDATED 09/01/2023

# PARTS IDENTIFICATION

## 2920-117 – SEALER ARM HUB ASSEMBLY

DET	QTY	PART NO.	DESCRIPTION
1	1	2570-375	HUB CAP, WILTON #909902
2	1	2531-102	1/8 X 1-1/4 COTTER PIN BLACK
3	1	2520-469	5/8-18 SLOTTED HEX NUT, BLACK
4	1	2526-449	5/8 FLATWASHER, 1/4 +- .010 THK
5	2	2550-027	CONE, LM67048
6	1	2900-105	HUB PRESSED ASSEMBLY
7	1	2550-066	TRIPLE LIP SEAL, NTI #1812-4
8	1	2900-135	HUB SUB-ASSEMBLY
9	1	2920-215	SEALER ARM W.A.
10	1	2533-110	1/4-28 ZERK STRAIGHT SELF-TAP
11	2	2550-029	CUP, EWC #LM67010
12	1	2555-115	FLOW COULTER HUB CASTING
13	1	2565-366	AVENGER COULTER DECAL

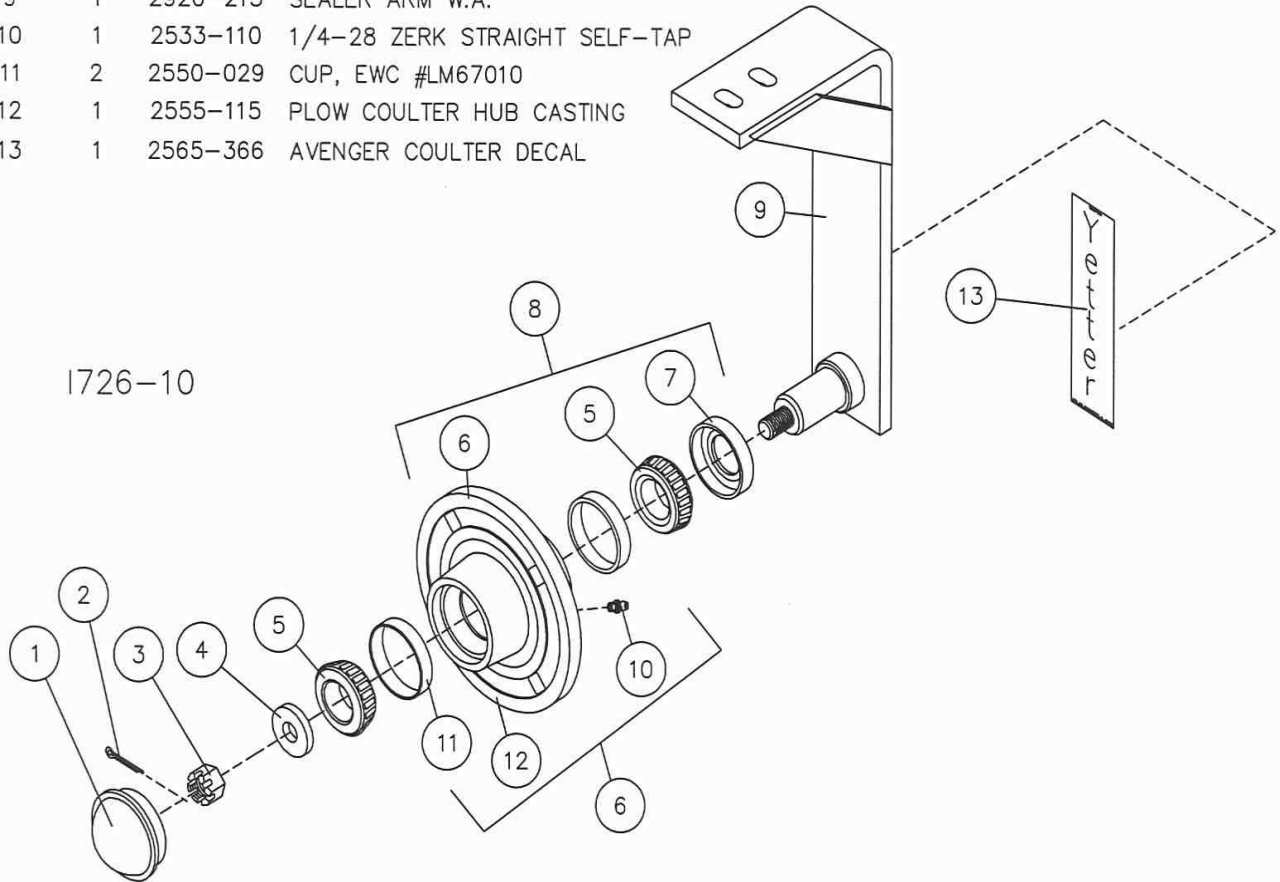

# PARTS IDENTIFICATION

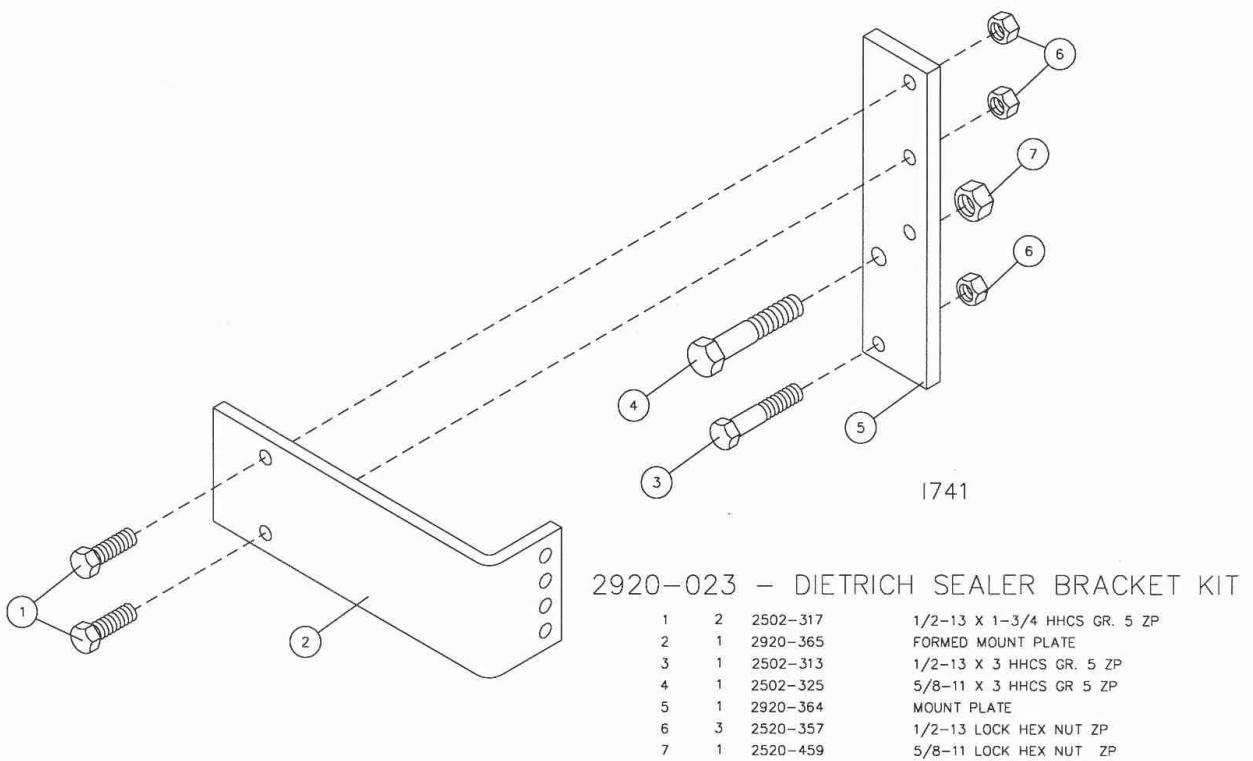

# TROUBLESHOOTING

Problem	Cause	Solution
Poor overall performance.	Toolbar not adjusted correctly	Adjust the toolbar so that during operation it is level.
Max Sealer Plus not creating a mound or too small of a mound.	Speed too slow.	Operate at 5mph min.
	Blades are not set aggressively enough	Increase the angle of the front edge of blade to the row.
	Toolbar is not level-probably nose down	Level toolbar.
Max Sealer Plus is not closing the knife track.	Blades are not set aggressive enough.	Curved blades the "cup" should be in toward the knife.
		Increase the angle of the front edge of the blade.



A Tradition of Solutions since 1930

Yetter Farm Equipment Co

PO BOX 358 109 S. McDonough

Colchester, IL 62326-0358

Phone: 309-776-4111

Toll Free: 800-447-5777

Email: [info@yetterco.com](mailto:info@yetterco.com)

For updated models and manuals visit the Yetter website:

[www.yetterco.com](http://www.yetterco.com)

© Yetter Farm Equipment Co. All Rights Reserved

2565-727\_REV\_C • 09/2023