



2967-042

TITAN™

**RESIDUE MANAGER
FOR
JOHN DEERE HD COULTER**

**OPERATOR'S MANUAL
PART IDENTIFICATION**

2565-754_REV_G • 01/2017

YETTER MANUFACTURING CO.
FOUNDED 1930

Colchester, IL 62326-0358
Toll free: 800/447-5777
309/776-3222 (Fax)
Website: www.yetterco.com
E-mail: info@yetterco.com

YETTER

FOREWORD

You've just joined an exclusive but rapidly growing club.

For our part, we want to welcome you to the group and thank you for buying a Yetter product.

We hope your new Yetter products will help you achieve both goals-increase your productivity and increase your efficiency so that you may generate more profit.

This operator's manual has been designed into four major sections: Foreword, Safety Precautions, Installation Instructions and Parts Breakdown.



This **SAFETY ALERT SYMBOL** indicates important safety messages in the manual. When you see this symbol, be alert to the possibility of **PERSONAL INJURY** and carefully read the message that follows.

The word **NOTE** is used to convey information that is out of context with the manual text. It contains special information such as specifications, techniques and reference information of a supplementary nature.

The word **IMPORTANT** is used in the text when immediate damage will occur to the machine due

to improper technique or operation. Important will apply to the same information as specified by note only of an immediate and urgent nature.

It is the responsibility of the user to read the operator's manual and comply with the safe and correct operating procedure and to lubricate and maintain the product according to the maintenance schedule in the operator's manual.

The user is responsible for inspecting his machine and for having parts repaired or replaced when continued use of the product would cause damage or excessive wear to the other parts.

It is the user's responsibility to deliver his machine to the Yetter dealer who sold him the product for service or replacement of defective parts, which are covered by the warranty policy.

If you are unable to understand or follow the instructions provided in this publication, consult your local Yetter dealer or contact:

YETTER MANUFACTURING CO.

309/776-4111

800/447-5777

309/776-3222 (FAX)

Website: www.yetterco.com

E-mail: info@yetterco.com

WARRANTY

Yetter Manufacturing warrants all products manufactured and sold by it against defects in material. This warranty being expressly limited to replacement at the factory of such parts or products as shall appear to be defective after inspection. This warranty does not obligate the Company to bear cost of labor in replacement of parts. It is the policy of the Company to make improvements without incurring obligations to add them to any unit already sold. No warranty is made or authorized to be made, other than herein set forth. This warranty is in effect for one year after purchase.

DEALER: _____

Yetter Manufacturing warrants its own products only and cannot be responsible for damages to equipment on which mounted.

SAFETY

A brief description of signal words that may be used in this manual:

CAUTION: Used as a general reminder of good safety practices or to direct attention to unsafe practices.

WARNING: Denotes a specific potential hazard.

DANGER: Denotes the most serious specific potential hazard.

SAFETY PRECAUTIONS

You can make your farm a safer place to live and work if you observe the safety precautions given. Study these precautions carefully and insist that those working with you and for you follow them.

Finally, remember this: an accident is usually caused by someone's carelessness, neglect or oversight.



WARNING

Never clean, lubricate or adjust a machine that is in motion. Always lower or block the implement before performing service.

If the machine must be serviced in the raised position, jack or block it up to prevent it from accidentally falling and injuring someone.

Do not allow riders on the tractor or implement.

Use speeds and caution dictated by the terrain being traversed. Do not operate on any slope steep enough to cause tipping or loss of control.

Be sure all personnel are clear of the immediate area before operating.

Read and understand the operator's manual and require all other persons who will operate the equipment to do the same.

Be familiar with all tractor and implement controls and be prepared to stop engine and implements quickly in an emergency.



CAUTION

Consult your implement and tractor operator's manual for correct and safe operating practices.

Beware of towed implement width and allow safe clearance.

FAILURE TO HEED MAY RESULT IN PERSONAL INJURY OR DEATH.

TABLE OF CONTENTS

Introduction.....	2
Warranty.....	2
Safety Information.....	2-3
Table of Contents.....	4
Optional Equipment.....	4
Torque.....	5
Installation Instruction.....	6-7
Operation.....	8
Maintenance.....	9-14
Parts Identification.....	15

OPTIONAL EQUIPMENT

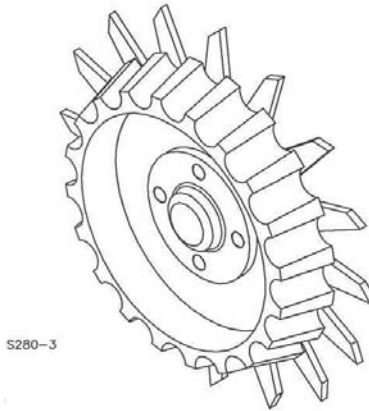

2967-186 FLOATER WHEEL
L.H. ASSEMBLY SHOWN
(2) REQUIRED PER ROW

BOLT TORQUE

Mounting bolts and hardware

Before operating the Titan™ Residue Manager for the first time, check to be sure that all hardware is tight. Check all hardware again after approximately 50 hours of operation and at the beginning of each planting season.

All hardware used on the Titan™ Residue Manager is Grade 5 unless otherwise noted. Grade 5 cap screws are marked with three radial lines on the head. If hardware must be replaced, be sure to replace it with hardware of equal size, strength and thread type. Refer to the torque values chart when tightening hardware.







Important: Over tightening hardware can cause as much damage as when under tightening. Tightening hardware beyond the recommended range can reduce its shock load capacity.

The chart below is a guide for proper torque. Use it unless a specified torque is called out elsewhere in the manual.

Torque is the force you apply to the wrench handle or the cheater bar, times the length of the handle or bar.

Use a torque wrench whenever possible.

The following table shows torque in ft. lbs. for coarse thread hardware.

BOLT DIA. AND THREADS PER INCH	 GRADE 2	 OR  GRADE 5 A-325	 GRADE 8
1/4	6	10	14
5/16	12	20	30
3/8 - 16	25	35	50
7/16 - 14	35	55	80
1/2 - 13	55	85	125
9/16 - 12	75	125	175
5/8 - 11	105	170	235
3/4 - 10	185	305	425
7/8 - 9	170	445	690
1-8	260	670	1030
1 1/8 - 7	365	900	1460
1 1/4 - 7	515	1275	2060
1 3/8 - 6	675	1675	2700
1 1/2 - 6	900	2150	3500
1 3/4 - 5	1410	3500	5600

Lubricate all bearings and moving parts as assembled and make certain that they work freely.



WARNING: Never work around the toolbar/implement while in a raised position without using safety lockups.



CAUTION: The Residue manager attachments are very heavy. Pay extra attention to lifting techniques while handling and or maneuvering the opener during assembly. Failure to do so may lead to personal injury.

2967-042 – TITAN™ FOR JOHN DEERE COULTER

INSTALLATION INSTRUCTIONS

STEP 1. Install the 2966-170 mount bracket and the JD coulters using the M12 X 45MM locknuts.

Tighten the bolts snug where the coulters can be moved as needed

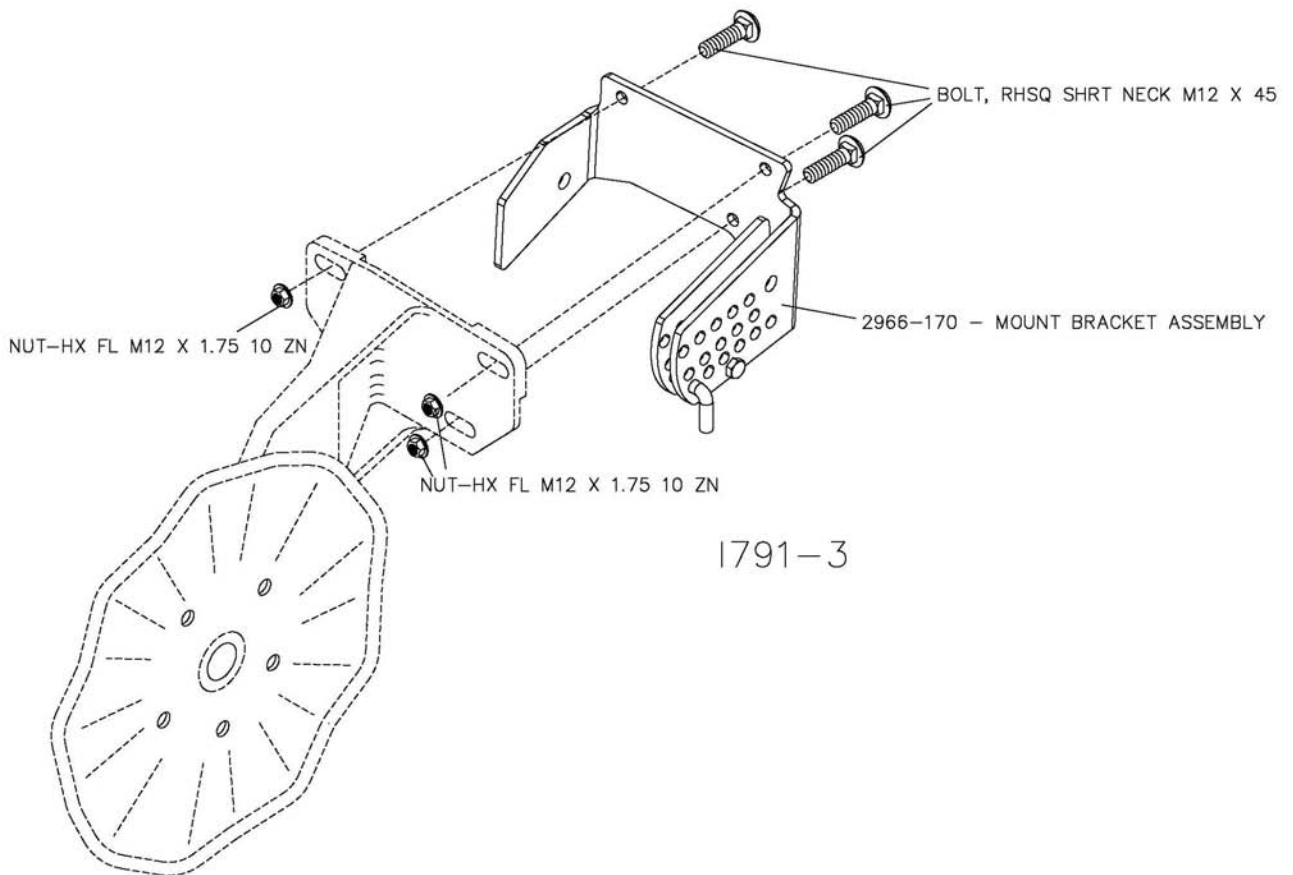

INSTALLATION INSTRUCTIONS

STEP 2. Attach the residue manager arm/wheel assembly using the M16 X 45 Hex Flange Screw, bushing, and locknuts. **Do not fully tighten.**

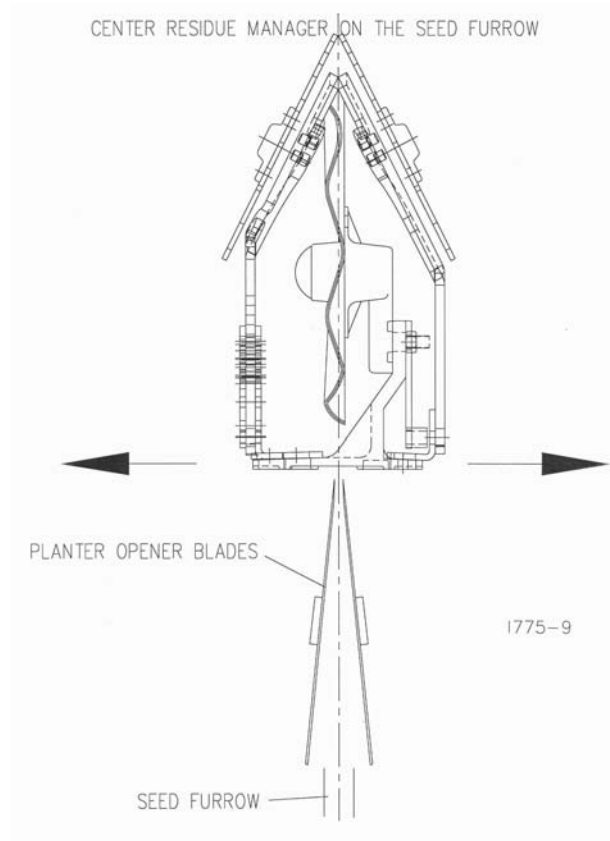
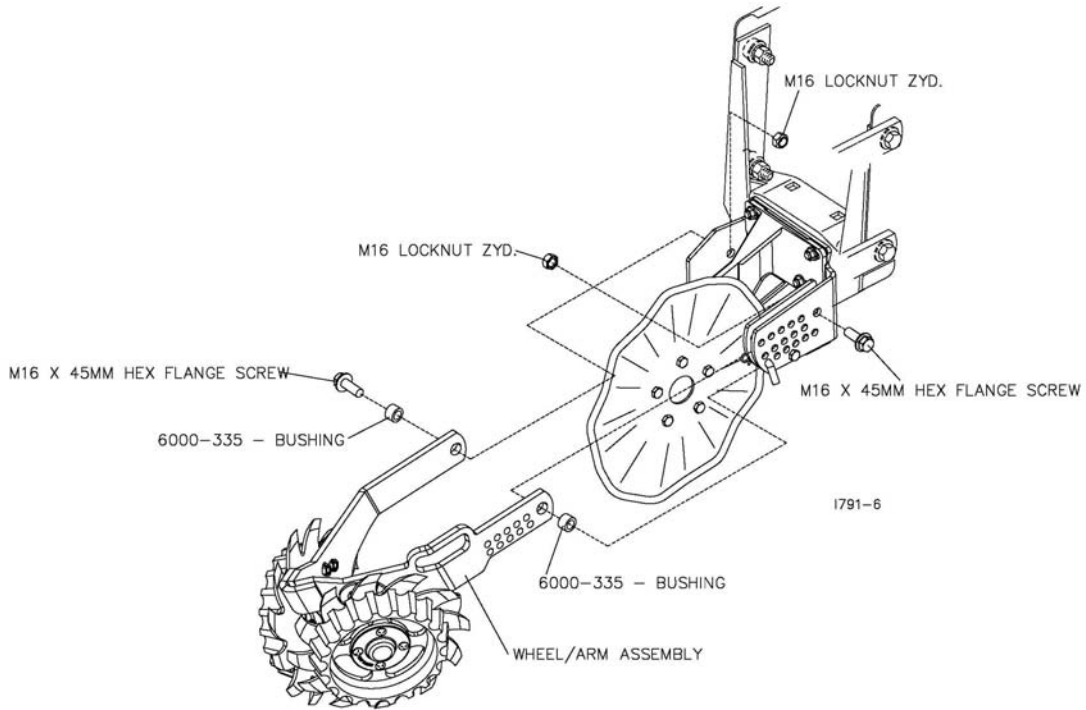

OPERATION

CAUTION: Where rocks are present the residue manager should be set in the “float” position, not locked down.

STEP 1. Adjust the residue manager to move crop residue aside and not move any soil. Adjustments to the residue manager may have to be made when changing field conditions and type and amount of residue. Use the handle for leverage when changing depth settings.

“FLOAT SETTINGS”

Install the adjustment pin below the combo arm.

“RIGID SETTING”

Install the adjustment pin through the combo arm.

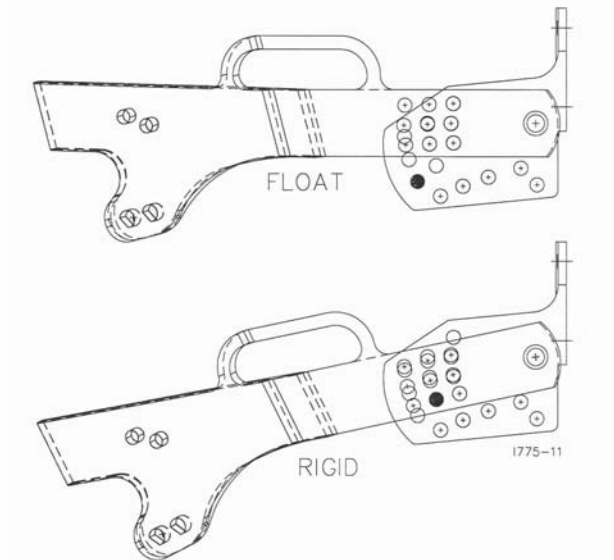

ROW CLEANER DO'S AND DON'TS

1. **DO NOT** move soil; Residue Managers are designed to move crop residue only.
2. **DO NOT** operate planter at slow speeds, ground speed affects how aggressive the spoke wheels are; operate at sufficient speed (4-6 mph) to maintain good residue flow.
3. **DO NOT** expect 100% of crop residue to be cleared, it is not necessary and would necessitate engaging the soil. The width of path cleared depends on ground conditions, depth setting and ground speed.
4. **DO** expect to see wheels occasionally quit turning, indicates ideal (shallow) setting which is not moving soil.

DO adjust toolbar frame height 20”-22” and drawbar to “level” correctly. Very important to ensure planter opener will follow ground contours properly.

IMPORTANT: For proper operation, the planter frame must operate level (for, aft and side to side) and at the correct height, typically 20”-22”.

MAINTENANCE

STEP 1. Regularly inspect the residue manager for loose or worn parts. Repair and replace as needed.

MAINTENANCE

BEARING ASSEMBLY AND LUBRICATION

Practice Safety

Understand and practice safe service procedures before doing work. Follow ALL the operating, maintenance and safety information in the equipment operator manual. Clear the area of bystanders, especially small children, when performing any maintenance or adjustments. Keep work area clean and dry. Use adequate lighting for the job. Use only tools, jacks and hoists of sufficient capacity for the job.

Never lubricate, service, or adjust machine while it is moving. Keep hands, feet, and clothing from power-driven moving and rotating parts. Disengage all power and operate controls to relieve pressure. Lower equipment to the ground and stop the engine. Remove the key. Wait for all moving parts to stop before servicing, adjusting, repairing or unplugging.

Securely support any machine elements with blocks or safety stands that must be raised for service work.

Keep all parts in good condition and properly installed. Fix damaged equipment immediately. Replace worn or broken parts. Remove any buildup of grease, oil, or debris. Make sure all guards are in place and properly secured when maintenance work is completed.

Assembly

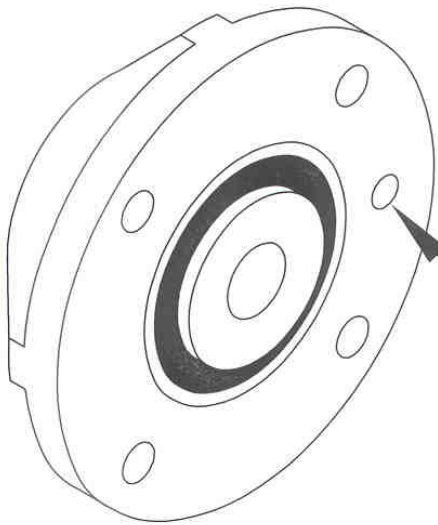

ALIGN GREASE
FITTING HOLES.

1190-1

MAINTENANCE

ALIGN THE HUB CAP GROOVE,
WITH THE WHEEL SLOT AND
GREASE FITTING

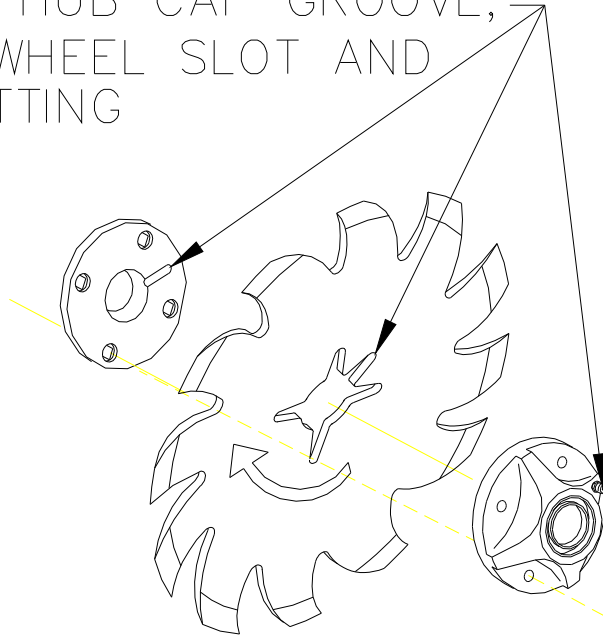

NOTE: Be certain to align the grease fitting with the slot in the wheel and the hubcap so that the grease can flow freely.

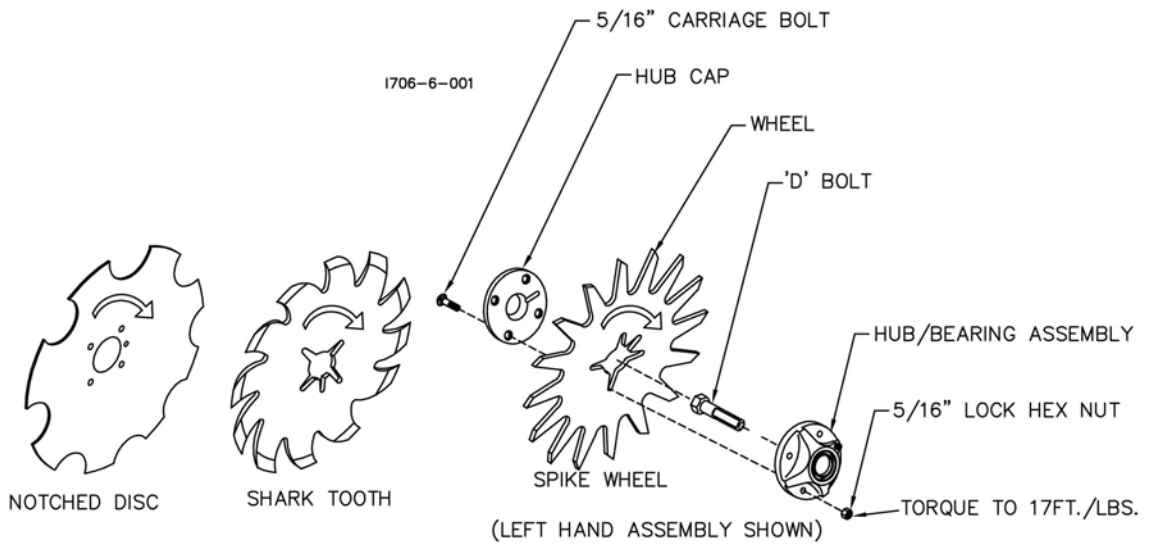

MAINTENANCE

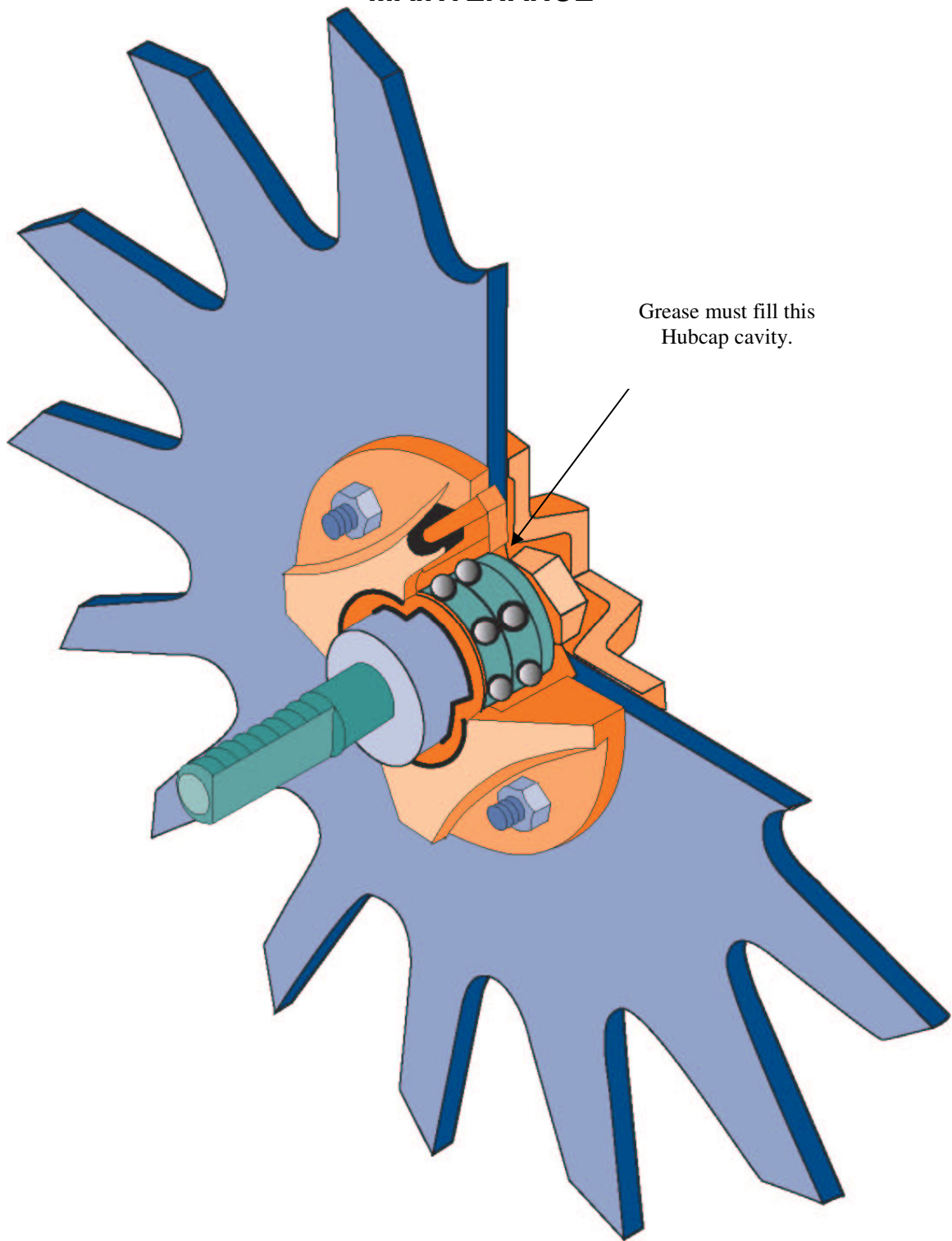

Grease must fill this
Hubcap cavity.

MAINTENANCE

Lubrication



CAUTION: To help prevent serious injury or death to you or others caused by unexpected movement, service machine on a level surface. Lower machine to ground or sufficiently lock or block raised machine before servicing. If machine is connected to tractor, engage parking brake and place transmission in "PARK", shut off engine and remove key. If machine is detached from tractor, block wheels and use shop stands to prevent movement.



CAUTION: Do not clean, lubricate, or adjust machine while in motion.

IMPORTANT: USE POLYUREA GREASE

Use grease based on NLGI consistency numbers and the expected air temperature range during the service interval.

Use a **multi-purpose SD POLYUREA, water resistant and NLGI grade #2** grease.

Other greases may be used if they meet the following **NLGI Performance**

Classification: GC-LB

IMPORTANT: Some types of grease thickener are not compatible with others.

Consult your grease supplier before mixing different types of grease.

Alternative Lubricants

Conditions in certain geographical areas may require special lubricants and lubrication practices which do not appear in the operator's manual. If there are any questions, consult Yetter Manufacturing Co. to obtain latest information and recommendation.

PART #	DESCRIPTION	OUNCES OF GREASE
2967-404	13" TAPER TOOTH R.M. WHEEL	1.12 OZ
2967-602	13" SHARK TOOTH R.M. WHEEL	1.12 OZ
2967-186	FLOATER WHEEL KIT W/R.M. WHEEL	2.08 OZ
2967-596	HEAVY DUTY OR BEVEL R.M. WHEEL W/ FLOATER WHEEL KIT	2.40 OZ

Storing Lubricants

Your machine can operate at top efficiency only if clean lubricants are used.

Use clean containers to handle all lubricants.

Store them in an area protected from dust, moisture and other contaminants.

MAINTENANCE

Lubrication Symbols



Lubricate with grease at hourly interval indicated on symbol.

Lubrication Intervals

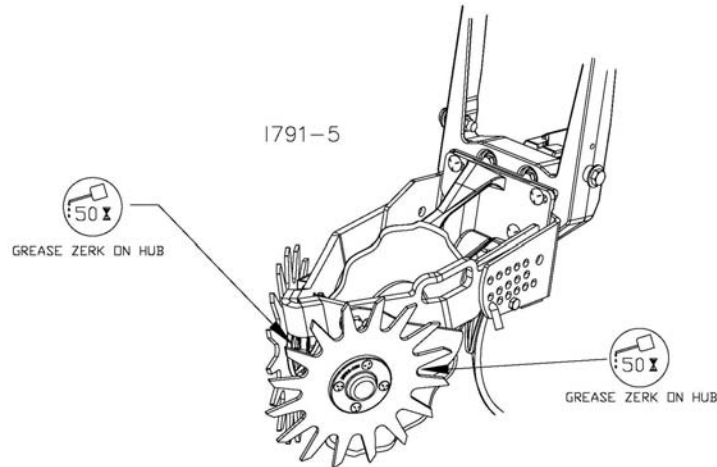

IMPORTANT: The recommended service intervals are based on normal conditions; severe or unusual conditions may require more frequent lubrication.

Perform each lubrication and service procedure at the beginning and end of each season. Clean grease fittings before using grease gun, to avoid injecting dirt and grit into the bearing. Replace any lost or broken fittings immediately. If a fitting fails to take grease, remove and clean thoroughly, replace fitting if necessary. Also check for failure of adjoining parts.

BEARING REPLACEMENT INSTALLATION

1. When assembling the spoke wheels, bearing assembly and hubcap, be sure to align the grease transfer hole in the spoke wheel with the groove in the hubcap and hole in the hub to allow grease passage.
2. Assemble the wheels, hubs and caps
3. Grease the wheel/hub/bearing assembly.

MAINTENANCE

Storing the Equipment

Store the machine in an area away from human activity

Store machine in RAISED position.

Install service locks on all wheel cylinders.

At the end of the season, the machine should be thoroughly inspected and prepared for storage. Repair or replace any worn or damaged components to prevent down time at the start of the next season. Store machine under cover with all parts in operating condition.

- Clean machine thoroughly to remove all dirt, debris and crop residue, which would hold moisture and cause rusting.
- Inspect machine for worn or broken parts. See your Yetter Farm Equipment dealer during the off-season so that parts or service can be acquired when machine is not needed in the field.
- Lubricate bearings as outlined in the Lubrication section
- Paint all parts which are chipped or worn and require repainting.
- Store machine in a clean, dry place with the planting unit out of the sun.
- If the machine cannot be stored inside, cover with a waterproof tarpaulin and tie securely in place.
- Do not allow children to play on or around the machine

PARTS IDENTIFICATION

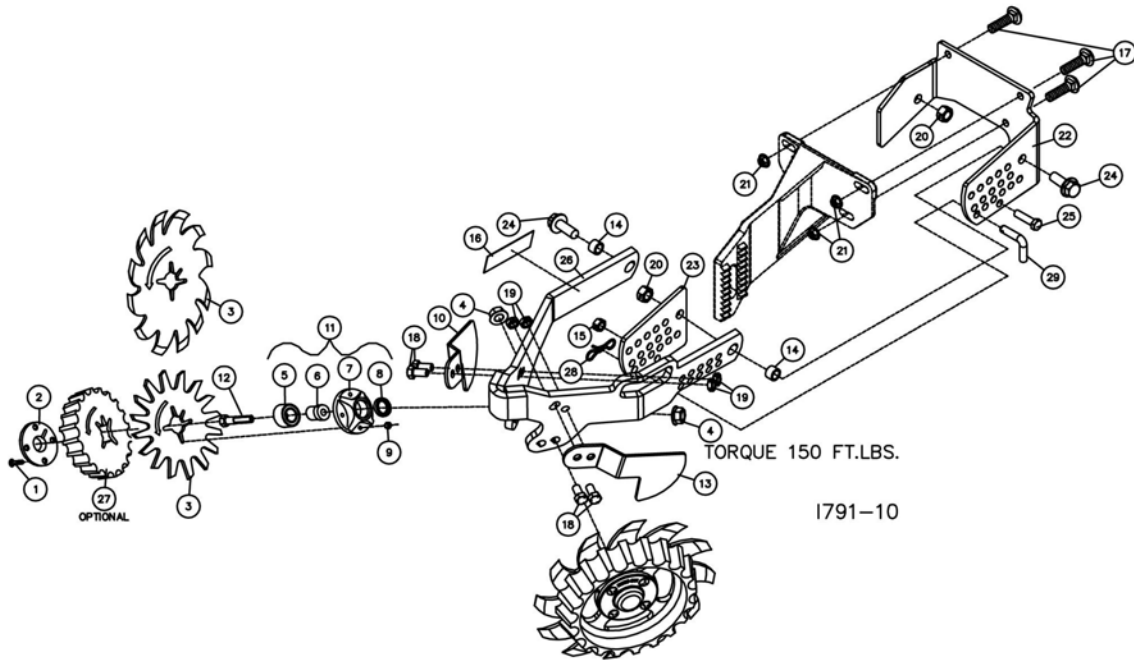

2967-042 – TITAN FOR JD HD COULTER

DET	QTY	PART NO.	DESCRIPTION	DET	QTY	PART NO.	DESCRIPTION
1	8	2505-207	5/16-18 X 1 1/4 CAR BLT GR5	14	2	6000-335	9/16" BUSHING
	8	2505-208	5/16-18 X 1 1/2 CAR BLT GR5 (USE WITH HEAVY DUTY WHEELS ONLY)	15	1	2520-700	HEX LOCKNUT DEFLCTD THREAD-M12
	8	2505-209	5/16-18 X 1 3/4 CAR BLT GR5 (USE WITH FLOATER WHEEL OPTION)	16	1	2565-162	YETTER DECAL, 1-1/2 X 4-1/2
2	2	2965-352	HUB CAP CASTING, 4 BOLT, BLACK	17	3	2502-801	BOLT, RHSQ SHRT NECK M12 X 1.75
3	2	2967-404	13" TAPER TOOTH SPOKE WHEEL (SHOWN)	18	4	2502-293	1/2-13 X 1-1/4 HHCS GR5 YD
	2	2967-596	3/8" TAPER TOOTH SPOKE WHEEL	19	4	2520-364	1/2-13 HEX LOCKNUT, JAM ZP
	2	2967-602	13" SHARK TOOTH WHEEL	20	2	2520-474	M16 LOCK NUT ZYD.
4	2	2520-464	5/8-11 WHIZLOCK HEX NUT, ZP	21	3	2520-701	NUT-HX FL M12 10 ZN
5	2	2570-594	BEARING, 2 ROW NTN# DF0654L	22	1	2966-250	FACE PLATE W.A.
6	2	2570-715	BEARING INSERT, TRASHMASTER	23	1	2967-741	PIN ADJ. PLATE
7	2	2965-351	HUB CAST.,MACHINED, 4 BOLT	24	2	2502-802	M16 X 45MM HEX FLANGE SCREW
8	2	2550-069	SEAL, TRIPLE LIP, NTI# 1812-5	25	1	2502-800	12MM X 1.75 X 45 HHCS GR8
9	8	2520-206	5/16-18 HEX FLANGE SERRATED NUT	26	1	2966-254	PIN ADJ COMBO ARM W.A.
10	1	2967-630	SCRAPER, R.H.	27	2	2967-555	FLOATER WHEEL (OPTIONAL)
11	2	2965-128	HUB AND BEARING ASS'Y.,4 BOLT	28	1	2570-448	1/8 BOWTIE LOCKING COTTER ZYD
12	2	2570-766	D-BOLT, FLANGE, 5/8-11 X 2-1/2 GR8 ZYD	29	1	2967-613	TITAN PIN, JD, ZYD
13	1	2967-631	SCRAPER, L.H.				

07/08/16

MANUFACTURED 6/2009 – 5/2016

Our name Is getting known

Just a few years ago, Yetter products were sold primarily to the Midwest only. Then we embarked on a program of expansion and moved into the East, the South, the West and now north into Canada. We're even getting orders from as far away as Australia and Africa.

So, when you buy Yetter products . . .you're buying a name that's recognized. A name that's known and respected. A name that's become a part of American agriculture and has become synonymous with quality and satisfaction in the field of conservation tillage.

Thank you.

YETTER MANUFACTURING CO.
Colchester, IL 62326-0358 ☎ 309/776-4111
Toll Free 800/447-5777
Fax 309/776-3222
Website: www.yetterco.com
E-mail: info@yetterco.com

2565-754_REV_G ☎ 01/2017