



2940 HYDRAULIC AIR ADJUST RESIDUE MANAGER

OPERATOR'S MANUAL
PART IDENTIFICATION
2565-779_REV_C • 02/15



*Patented

YETTER MANUFACTURING CO.
FOUNDED 1930

Colchester, IL 62326-0358
Toll free: 800/447-5777

309/776-3222 (Fax)

Website: www.yetterco.com

E-mail: info@yetterco.com

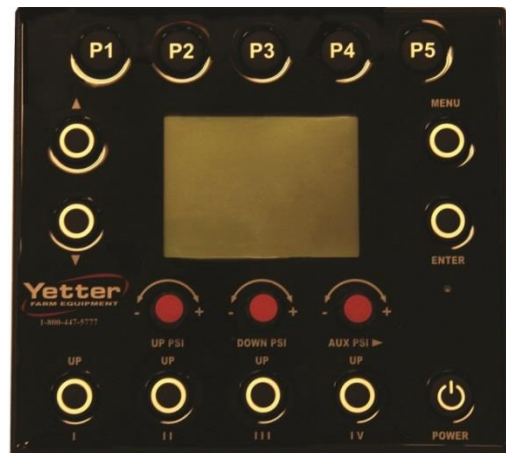

YETTER

TABLE OF CONTENTS

Bolt Torque.....	2
Safety.....	4
Hydraulic Fittings Chart.....	5
Components, Kits, and Part Numbers.....	6-9
Introduction & System Requirements.....	10
System Information.....	11-15
Installation Guide.....	16-18
Residue Manager Installation.....	19-20
Residue Manager/Coulter Combo Installation.....	21-22
Cab Controller Installation.....	23
Yetter Hydraulic Compressor Installation.....	24-26
2940-103 Control Box Installation.....	27
2940-415 Water Separator/Regulator Assembly Installation.....	27
Compressor to Control Box Airline Installation.....	28
Cab Controller to Control Box Wiring Harness Installation.....	29
Dump Valve Installation.....	30
Airline & Dump Valve Cable Installation.....	31-64
Operation.....	65-70
Pre-Field Operation.....	71-72
Maintenance.....	73-77
Parts Identification.....	78-103
Troubleshooting.....	104



BOLT TORQUE



Mounting bolts and hardware

All hardware used on the 2940 Air Adjust is Grade 5 unless otherwise noted. Grade 5 cap screws are marked with three radial lines on the head. If hardware must be replaced, be sure to replace it with hardware of equal size, strength and thread type. Refer to the torque values chart when tightening hardware.

Important: Over tightening hardware can cause as much damage as when under tightening. Tightening hardware beyond the recommended range can reduce its shock load capacity.

The chart below is a guide for proper torque. Use it unless a specified torque is called out elsewhere in the manual. Torque is the force you apply to the wrench handle or the cheater bar, times the length of the handle or bar. Use a torque wrench whenever possible.

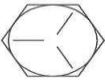
The following table shows torque in ft. lbs. for coarse thread hardware.

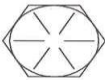
BOLT DIA. AND THREADS PER INCH	 GRADE 2	 OR  GRADE 5 A-325	 GRADE 8
3/8-16	25	35	50
7/16-14	35	55	80
1/2-13	55	85	125
9/16-12	75	125	175
5/8-11	105	170	235
3/4-10	185	305	425
7/8-9	170	445	690
1-8	260	670	1030
1 1/8-7	365	900	1460
1 1/4-7	515	1275	2060
1 3/8-6	675	1675	2700
1 1/2-6	900	2150	3500
1 3/4-5	1410	3500	5600

FOREWORD

You've just joined an exclusive but rapidly growing club.

For our part, we want to welcome you to the group and thank you for buying a Yetter product.

We hope your new Yetter products will help you achieve both goals-increase your productivity and increase your efficiency so that you may generate more profit.

This operator's manual has been designed into four major sections: Foreword, Safety Precautions, Installation Instructions and Parts Breakdown.



This **SAFETY ALERT SYMBOL** indicates important safety messages in the manual. When you see this symbol, be alert to the possibility of **PERSONAL INJURY** and carefully read the message that follows.

The word **NOTE** is used to convey information that is out of context with the manual text. It contains special information such as specifications, techniques and reference information of a supplementary nature.

The word **IMPORTANT** is used in the text when immediate damage will occur to the machine due

to improper technique or operation. Important will apply to the same information as specified by note only of an immediate and urgent nature.

It is the responsibility of the user to read the operator's manual and comply with the safe and correct operating procedure and to lubricate and maintain the product according to the maintenance schedule in the operator's manual.

The user is responsible for inspecting his machine and for having parts repaired or replaced when continued use of the product would cause damage or excessive wear to the other parts.

It is the user's responsibility to deliver his machine to the Yetter dealer who sold him the product for service or replacement of defective parts, which are covered by the warranty policy.

If you are unable to understand or follow the instructions provided in this publication, consult your local Yetter dealer or contact:

YETTER MANUFACTURING CO.

309/776-4111

800/447-5777

309/776-3222 (FAX)

Website: www.yetterco.com

E-mail: info@yetterco.co

WARRANTY

Yetter Manufacturing warrants all products manufactured and sold by it against defects in material. This warranty being expressly limited to replacement at the factory of such parts or products as shall appear to be defective after inspection. This warranty does not obligate the Company to bear cost of labor in replacement of parts. It is the policy of the Company to make improvements without incurring obligations to add them to any unit already sold. No warranty is made or authorized to be made, other than herein set forth. This warranty is in effect for one year after purchase.

DEALER: _____

Yetter Manufacturing warrants its own products only and cannot be responsible for damages to equipment on which mounted.

SAFETY

A brief description of signal words that may be used in this manual:

CAUTION: Used as a general reminder of good safety practices or to direct attention to unsafe practices.

WARNING: Denotes a specific potential hazard.

DANGER: Denotes the most serious specific potential hazard.

SAFETY PRECAUTIONS

You can make your farm a safer place to live and work if you observe the safety precautions given. Study these precautions carefully and insist that those working with you and for you follow them.

Finally, remember this: an accident is usually caused by someone's carelessness, neglect or oversight.



WARNING

Never clean, lubricate or adjust a machine that is in motion. Always lower or block the implement before performing service.

If the machine must be serviced in the raised position, jack or block it up to prevent it from accidentally falling and injuring someone.

Do not allow riders on the tractor or implement.

Use speeds and caution dictated by the terrain being traversed. Do not operate on any slope steep enough to cause tipping or loss of control.

Be sure all personnel are clear of the immediate area before operating.

Read and understand the operator's manual and require all other persons who will operate the equipment to do the same.

Be familiar with all tractor and implement controls and be prepared to stop engine and implements quickly in an emergency.



CAUTION

Consult your implement and tractor operator's manual for correct and safe operating practices.

Beware of towed implement width and allow safe clearance.

FAILURE TO HEED MAY RESULT IN PERSONAL INJURY OR DEATH.

Hydraulic Fittings Identification Chart

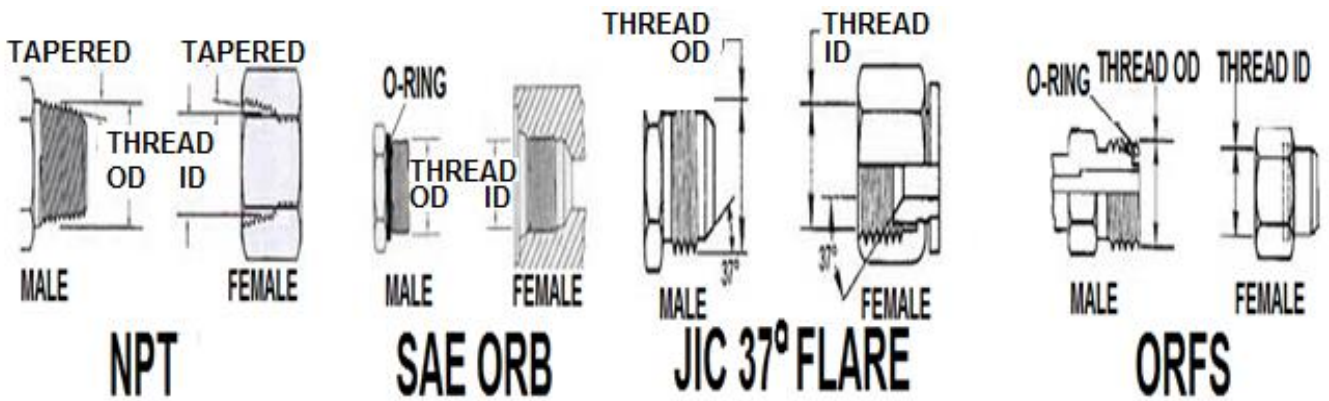

Nominal Size	Dash Size	Nominal Thread	Male Thd OD	Female Thd ID	Nominal Thread	Male Thd OD	Female Thd ID	Nominal Thread	Male Thd OD	Female Thd ID	Nominal Thread	Male Thd OD	Female Thd ID
1/8	02	1/8-27	0.41	0.38	5/16-24	0.31	0.27	5/16-24	0.31	0.27	NOT AVAILABLE		
3/16	03	NOT AVAILABLE			3/8-24	0.38	0.34	3/8-24	0.38	0.34	NOT AVAILABLE		
1/4	04	1/4-18	0.54	0.49	7/16-20	0.44	0.39	7/16-20	0.44	0.39	9/16-18	0.56	0.51
5/16	05	NOT AVAILABLE			1/2-20	0.50	0.45	1/2-20	0.50	0.45	NOT AVAILABLE		
3/8	06	3/8-18	0.68	0.63	9/16-18	0.56	0.51	9/16-18	0.56	0.51	11/16-16	0.69	0.63
1/2	08	1/2-14	0.84	0.77	3/4-16	0.75	0.69	3/4-16	0.75	0.69	13/16-16	0.82	0.75
5/8	10	NOT AVAILABLE			7/8-14	0.88	0.81	7/8-14	0.88	0.81	1-14	1.00	0.93
3/4	12	3/4-14	1.05	0.98	1 1/16-12	1.06	0.98	1 1/16-12	1.06	0.98	1 3/16-12	1.19	1.11
7/8	14	NOT AVAILABLE			1 13/16-12	1.19	1.10	1 13/16-12	1.19	1.10	NOT AVAILABLE		
1	16	1-11 1/2	1.32	1.24	1 5/16-12	1.31	1.23	1 5/16-12	1.31	1.23	1 7/16-12	1.44	1.36
1 1/4	20	1 1/4-11 1/2	1.66	1.58	1 5/8-12	1.63	1.54	1 5/8-12	1.63	1.54	1 11/16-12	1.69	1.61
1 1/2	24	1 1/2-11 1/2	1.90	1.82	1 7/8-12	1.88	1.79	1 7/8-12	1.88	1.79	2-12	2.00	1.92
2	36	2-11 1/2	2.38	2.30	2 1/2-12	2.50	2.42	2 1/2-12	2.50	2.42	NOT AVAILABLE		

- Due to common threads, mismatching can happen and could result in leaks and pressure loss
- Be sure to verify which style and use dash sizes when ordering replacement parts

Thread Styles

-NPT is easily recognizable as tapered National Pipe Thread. It is not recommended for hydraulic systems but does exist on some agriculture equipment. Teflon tape is required.

-SAE ORB is recommended by the NFPA for optimal leakage control in medium and high pressure hydraulic systems. The male fitting has a straight thread and O-ring. The female port has a straight thread, a machined surface (minimum spot face) and a chamfer to accept the O-ring. The seal takes place by compressing the O-ring in the chamfer. The threads hold the connection mechanically.

-JIC 37 Degree Flare fittings have a 37° cone seat on the female adapter and a 37° flare on the male adapter. This cone seat and flare allows for a complete mechanical seal between the male and female fitting. Teflon tape on threads is not required.

-ORFS (O-Ring Face Seal) adapter fittings use a straight thread and have a machined groove in the face of the male fitting to accept the O-ring. This O-ring is compressed against the flat face of the female fitting for a leak proof connection. ORFS are one of the newest types of hydraulic fittings.

Components, Kits, Accessories, & Ordering Numbers

Residue Manager Kits

2940-001	Pneumatic Residue Manager (RM) Assembly with choice of wheel kit
2940-002	Pneumatic Narrow RM Assembly with choice of wheel kit
2940-003	Pneumatic CNH RM Assembly with choice of wheel kit
2940-004	Pneumatic CNH Narrow RM Assembly with choice of wheel kit
2940-010	Pneumatic RM/Coulter Combo with choice of wheel kit







Air Lines and Wiring Kits

2940-053	Pneumatic Control Box
2940-055	Hydraulic Compressor Kit
2940-061	20/30FT Isobus Hydraulic Wiring and Tubing Kit
2940-062	40/44FT Isobus Hydraulic Wiring and Tubing Kit
2940-063	48/60/66FT Isobus Hydraulic Wiring and Tubing Kit
2940-064	80/90/120FT Isobus Hydraulic Wiring and Tubing Kit
2940-072	Split Row Kit
2940-073	Center Tube Extension Kit
2940-075	20/30FT Non Isobus Hydraulic Wiring and Tubing Kit
2940-076	40/44FT Non Isobus Hydraulic Wiring and Tubing Kit
2940-077	48/60/66FT Non Isobus Hydraulic Wiring and Tubing Kit
2940-078	80/90/120FT Non Isobus Hydraulic Wiring and Tubing Kit











Mounting Kits

2940-082	5X7 and 7X7 Bar Mount Kit (for 2940-103 Control Box)
2940-083	8X16 and 8X12 Bar Mount Kit (for 2940-103 Control Box)
2940-084	Universal Hand Rail Mount Kit (for 2940-103 Control Box)
2940-085	Two Point or Universal Hydraulic Compressor Mount Kit
2940-086	Draft Tube or Universal Hydraulic Compressor Mount Kit
2940-090	8X12 Bar Hydraulic Compressor Mount Kit
2940-091	8X16 Bar Hydraulic Compressor Mount Kit

Part Numbers and Descriptions

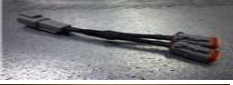
2940-049	Air Adjust Mount Ext. Kit (For JD HD scrapers)→	
2940-079	Switch Panel Resisted Adapter-----→	
2940-087	Rear Isobus Kit(John Deere Only)	
2940-088	Hydraulic Hose and Fitting Kit (Planter)	
2940-089	Hydraulic Hose and Fitting Kit (Stand Alone)	
2940-100	Data Panel/Cab Controller-----→	
2940-103	Control Box for Hydraulic Compressors-----→	
2940-105	Control Box with 2 PQEs for Hyd. Compressor	
2940-106	Hydraulic Compressor Unit-----→	
2940-112	VDM 12 Volt Controller-----→	
2940-113	RAM Cab Controller Mount Kit-----→	

Components, Kits, Accessories, & Ordering Numbers

2940-114	Stand Alone Hyd. Comp Control Kit----->	
2940-117	Hydraulic Manual Kit ISOBUS	
2940-118	J1 hydraulic conversion harness----->	
2940-123	Hydraulic Manual Kit (Yetter Monitor)	
2940-126	Pneumatic Combo Sub-Assembly (2940-010)	
2940-128	Mounting Bolt Bag – 2940-007 & 2940-010	
2940-130	Pneumatic Combo Sub-Assembly (2940-007)	
2940-135	Pressure on Valve for 2940-103----->	
2940-136	Dump Valve Kit----->	
2940-142	Mounting Bolt Bag-2940-001 & 2940-002	
2940-144	Mounting Bolt Bag-2940-100 Cab Controller	
2940-145	Mounting Bolt Bag-2940-003 & 2940-004	
2940-147	Package of 10 Tees----->	
2940-148	Package of Zip Ties (100) ----->	
2940-152	Hitch to Cab Controller CAN Cable----->	
2940-153	Cab Controller IGN/GRD Supply Harness-->	
2940-154	30 ft. Dump Valve Harness Black----->	
2940-155	30 ft. Dump Valve Harness White----->	
2940-156	15 ft. Dump Valve Harness Black	
2940-157	15 ft. Dump Valve Harness White	
2940-158	3 in. Y Harness Black----->	
2940-159	3 in. Y Harness White----->	
2940-160	5 ft Dump Valve Harness White	
2940-161	5 ft Dump Valve Harness Black	
2940-162	Dump Valve Harness at Compressor----->	
2940-164	5 ft CAN Aux To Air Harness----->	
2940-165	10 ft CAN Aux to Air Harness	

Components, Kits, Accessories, & Ordering Numbers

2940-166	VDM Power Cable with 40 Amp Breaker--->	
2940-167	10 ft VDM Power Cable Extension----->	
2940-168	20 ft VDM Power Cable Extension	
2940-169	10 ft Cab to Hitch Extension----->	
2940-170	10 ft CAN Aux to Air Harness Extension --->	
2940-171	30 ft CAN Aux To Air Harness Extension	
2940-174	Spare Fitting Bag	
2940-181	Hyd. Compressor Solenoid/Switch Harness->	
2940-182	20Ft Hyd. Compressor Control Harness----->	
2940-183	Bolt Bag for 2940-083 kit	
2940-184	Bolt Bag for 2940-084 kit	
2940-185	Bolt Bag for 2940-085 kit	
2940-186	Bolt Bag for 2940-086 kit	
2940-187	2940-010 Assembly/Mounting Bot Bag	
2940-189	10Ft Hyd. Compressor Control Harness	
2940-190	Pneumatic RM Mount Assembly	
2940-190-CIH	Pneumatic RM Mount Assembly for Case	
2940-191	Coulter/Combo Air Adjust Assembly	
2940-209	Mount Adaptor, CASE----->	
2940-306	6" Smaller Air Bag/Up Pressure Air Bag----->	
2940-308	8" Larger Air Bag/Down Pressure Air Bag--->	
2940-336	MAC Dump Valve----->	
2940-337	3/8 Push to Connect(PTC) elbow 1/8 NPT-->	
2940-338	3/8 PTC Tee----->	
2940-339	3/8 PTC Straight 1/8 NPT(pipe thread)----->	
2940-341	Air Tubing Cutter----->	
2940-342	Ball Valve----->	
2940-345	Black 3/8 Air Tubing 100ft roll----->	
2940-346	Blue 3/8 Air Tubing 100ft roll----->	

Components, Kits, Accessories, & Ordering Numbers

2940-352	3/8 PTC Plug (package of 5)----->	
2940-358	3/8 PTC Union, Straight----->	
2940-367	25ft Roll 250psi Working Pressure Tubing-->	
2940-374	Tee-1)1/4"NPT male, 2)1/4"NPT female ----->	
2940-376	Updated Water Separator Drain Valve Kit-->	
2940-402	Full PQE Unit----->	
2940-408	3/8PTC Elbow Fitting 1/4NPT----->	
2940-415	Water Separator/Regulator Assembly----->	
2940-430	20 ft CAN Aux to Air Harness Extension----->	
2940-439	0 – 160psi Hydraulic Compressor Gauge--->	
2940-441	Pressure Transducer----->	
2940-506	Hyd. Comp. Solenoid Coil Only	
2940-519	Hydraulic Compressor Fan----->	
2940-543	Hyd. Comp. Cartridge Valve (solenoid)	
2940-545	Rol-Air Compressor Pump Unit----->	
2940-546	Hydraulic Control Block----->	
2940-547	Hyd. Compressor Gasket Kit----->	
2940-548	Hydraulic Motor Seal Kit----->	
2940-549	Hydraulic Compressor Air Filter----->	
2940-550	Rol Air Synthetic Compressor Oil 1Liter---->	
2940-598	Plug Cap for Receptacle Protection----->	
2940-599	Plug Cap for Receptacle Protection(metal)->	

Introduction

The Yetter Hydraulic Air Compressor converts hydraulic power into compressed air. Yetter Hydraulic Compressor units are durably constructed and designed for easy integration to operate the Yetter 2940 Air Adjust System. The Yetter Hydraulic Air Compressor builds 145psi, the 2940-415 water separator/regulator assembly allows 120psi of clean, dry air to enter the 2940-103 control box and as the operator commands pressure on the cab controller, the row cleaners adjust on the go with no planting delay or downtime leading to more planting hours per day. The precise adjustments give the row units and planter a more even ride leading to more accurate seed placement and seed depth resulting in even emergence. **IF USING THE YETTER COMPRESSOR TO SUPPLY AIR TO OPERATE ANOTHER SYSTEM, INSTALL A REGULATOR PRIOR TO AIR ENTERING THAT SYSTEM WITH THE PROPER REGULATED AIR SETTINGS RECOMMENDED BY THE OEM PRODUCT.**

System Requirements

-The Yetter hydraulic compressor requires 4 gallons per minute maximum hydraulic flow to operate.

-OEM ELECTRIC COMPRESSORS ON PLANTERS ARE NOT AN ADEQUATE SOURCE OF AIR TO OPERATE THE YETTER 2940 AIR ADJUST SYSTEM!

-Lubrication of the pump requires a Grade 111 synthetic or PAO synthetic compressor oil. **THE PUMP IS SHIPPED EMPTY AND NEEDS OIL BEFORE OPERATING! SEE PAGE 73 FOR FILLING DETAILS!**

-Hydraulic oil flow is required to operate the hydraulic compressor's hydraulic motor. Different variables will determine the best way to connect into a hydraulic circuit to power the hydraulic motor. Connecting directly to a tractor's SCV port, teeing into the planter frame lift/lowering circuit, or teeing into the bulk tank blower circuit are examples of supplying hydraulic power to the compressor. Check OEM tractor and planter manual for hydraulic gpm output to make sure an adequate source is selected. **PTO DRIVEN HYDRAULIC CIRCUITS ARE NOT AN ADEQUATE SOURCE TO OPERATE THE YETTER HYDRAULIC COMPRESSOR!**

-Case Drain connection is required to carry the motor case internal leakage directly to the tractor hydraulic reservoir (sump) with zero pressure. This oil serves to lubricate and cool motor components not directly exposed to the working oil. It is normal to have seepage from this fitting when disconnected from the tractor to protect the motor seals from thermal expansion. If the tractor is not equipped with a female flat face case drain coupler, then a Case Drain Kit must be sourced through a dealer or hydraulic supplier.

Power Supply

The 2940-100 Cab Controller uses a switched power source. The 2940-153 will need connected to a switched power source. **THE CIGARETTE LIGHTER POWER SOURCE IS NOT A SWITCHED POWER SOURCE AND SHOULD NOT BE USED!** (Connector to the tractor not included)

SWITCHED POWER SOURCE CONNECTOR PART #'S:

JOHN DEERE P/N: RE67013

CNH P/N: 187103A1

The VDM (Valve Drive Module) inside the 2940-103 Control Box uses 12V from the tractor battery.

Fuse Protection

To protect the 2940-103 from damage always ensure the integrity of the integrated 40 amp breaker on the 2940-166 where connected to the tractor battery in case of short or over-circuit. When connected correctly, the tractor has a fuse to protect the cab controller located in the tractor's fuse panel.

Hydraulic Compressor Maintenance

To prolong life expectancy of the Yetter 2940-106 or the OEM hydraulic compressor, clean filter by removing the element from the filter housing, and tapping it, exposed side down. This will empty the pleats of the filter of collected dust. If the dust has been wet or will not clean out, call Yetter to order a new element, part number 2940-549 or if using an OEM hydraulic compressor, call your local dealer. You may lightly blow out the compressor housing using an air tool, however, **do not** blow out the filter element. The housing and filter should be checked every two days of field operation, or more if conditions are very dusty. **See pages 73-74 for further maintenance.**

2940 Air Adjust System Information

The 2940 Air Adjust Residue Manager control system consists of five primary components and kits. These parts include; the Cab Controller, Hydraulic Air Compressor Assembly, Control Box Kit, Residue Manager or Residue Manager/Coulter Combo Kit, and the Harnessing, Air Lines, and Fittings Kit.

Cab Controller

2940-100



The Cab Controller will use the RAM mount provided for installation in cab. Make adjustments quickly and accurately during planting with the cab controller. Adjust up and down pressure to create the ideal “ride” or floating position for residue managers. Lift and down pressure settings can be adjusted independently. Down pressure can be increased to fix row cleaner in the rigid position. Five presets can be programmed within the controller for quick changes. Residue Managers can be raised as needed with a push of the Roman numeral I up button.



Cab Controller Serial Number

Serial # is located on the back of the Cab control. See photo below.



Serial Number Location

Hydraulic Air Compressor Assembly



2940 Air Adjust requires a stable air supply source that can provide a minimum of 105 psi of clean, dry air. The 'clean, dry air' is a key component of the air supply, moisture within the air supply can shorten the life-cycle of the system.

Hydraulic Compressor External Diagram



Item	Description	QTY
A	Air Filter (2940-549)	1
B	Compressor Pressure Air Line	1
C	Output Elbow Fitting (2940-408)	1
D	Tank Pressure Gauge (2940-439)	1
E	Tank, 12 GAL	1
F	Pressure Relief Valve (2940-416)	1
G	Pressure Switch Connector	1
H	Pressure Switch (2940-377)	1
I	Hydraulic Return to Tank Port -8 ORFS	1
J	Hydraulic Pressure Inlet Port -6 ORFS	1
K	Hydraulic Control Block (2940-546)	1
L	Flow Control Valve	1
M	On/Off Valve (2940-506 = coil only, 2940-543 = cartridge valve)	1
N	Tank Drain (valve not visible)	1

Hydraulic Compressor External Diagram

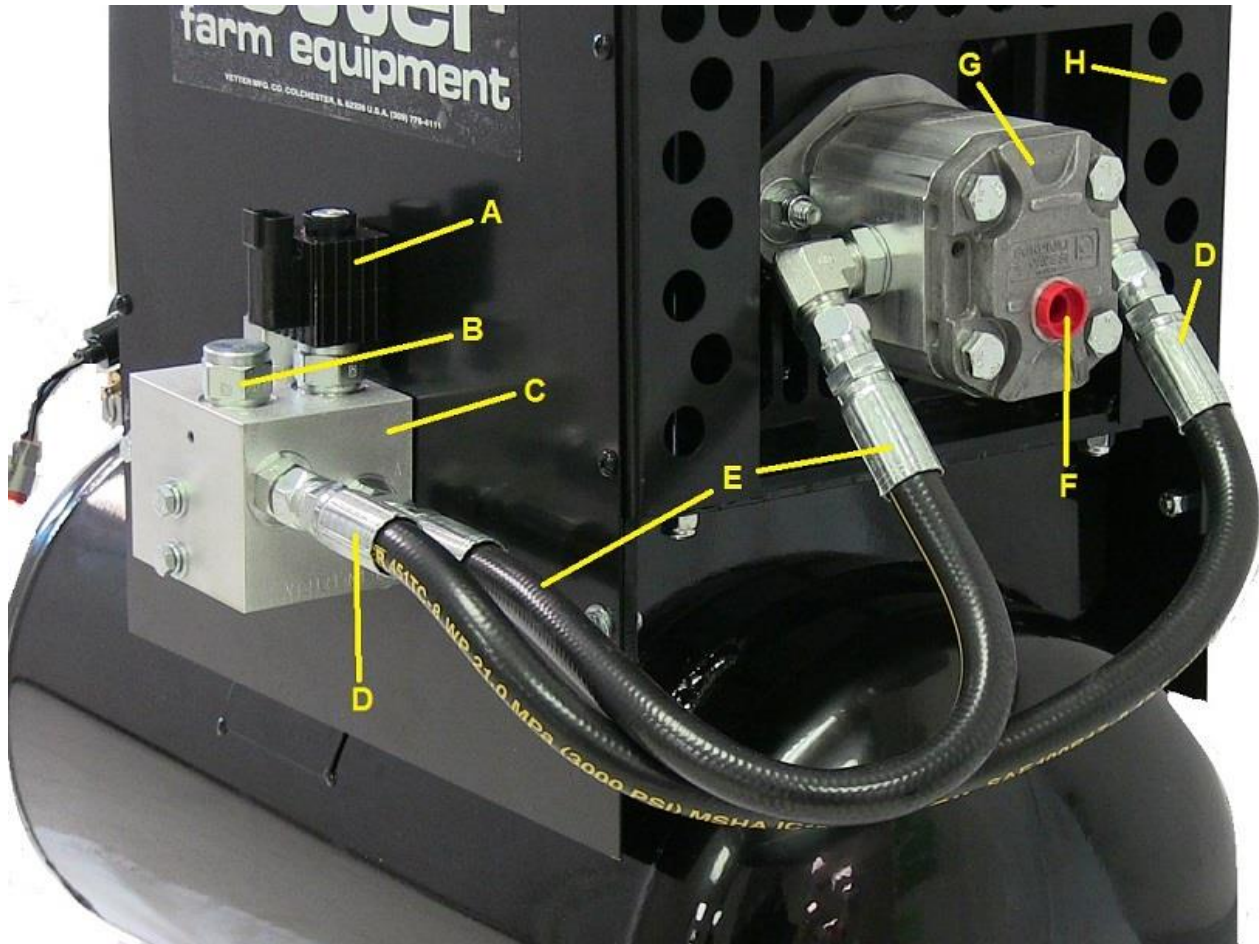

<u>Item</u>	<u>Description</u>	<u>QTY</u>
A	Hydraulic On/Off Valve	1
B	Check Valve	1
C	Hydraulic Control Block	1
D	Return to Tank Hose	1
E	Pressure Inlet hose	1
F	Case Drain Port -6 ORFS	1
G	Hydraulic motor	1
H	Housing Assembly	1

Control Box



The 2940-103 control box communicates with the 2940-100 cab controller via the VDM and dispenses air out of the PQE as the operator commands it. The VDM is the drive module that is programmed to carry out each function of the system. **Serial # is located on the front of the VDM in the compressor assembly. See photo below.**



2940-103 Control Box External Lay Out

Serial Number Location



- A. **WHEEL TRACK DOWN PRESSURE PORT-** Safely route black airline from the WT port to the inlet port of the down pressure dump valve on the center/wheel track rows of the planter. The down pressure PSI on the center section residue managers(RM) or RM/Coulter Combo can be adjusted separately than the wing/side section down pressure psi. If the WT port is not used, install a 2940-352 plug to prevent air loss.
- B. **RESIDUE MANAGER DOWN PRESSURE PORT-** Safely route black airline from the RD port to the inlet port on the down pressure dump valves on the wing/outer sections of the planter. This port dispenses down pressure to the RM or RM/Coulter Combos on the wing/side of the planter as commanded from the cab controller.
- C. **RESIDUE MANAGER UP PRESSURE PORT-** Safely route blue airline from the RU port to the inlet port of the up pressure dump valves on each section of the planter. This port dispenses up pressure to each RM or RM/Coulter Combo on the planter.
- D. **12 PIN DEUTSCH CONNECTOR (BLACK)-** Depending on application, route 2940-164 or 2940-165 CAN Aux cable from rear of the tractor to this female connector. If the control box is mounted at the rear of the planter, 2940-170, 2940-171, or 2940-430 CAN Aux extensions will route to this female connector.
- E. **12 PIN DEUTSCH CONNECTOR (GRAY)-** Connect the 2940-162 dump valve cable and route to the dump valves. The 2 pin cable labeled RM Up Dump routes to all up pressure dump valves. The 2 pin cable labeled RM Down Dump routes to all down pressure dump valves. The 2 pin cables labeled Aux 3 and Aux 4 are not used at this time.
- F. **MAIN AIR SUPPLY INLET-** Plumb the 2940-367 250psi rated 3/8" airline from the hydraulic compressor to the inlet of the water separator/regulator assembly. Plumb 2940-345 3/8" black airline from outlet of the water separator/regulator assembly to this port.
- G. **ACCESSORY AIR OUTPUT-** Remove brass cap to install fitting for miscellaneous uses.(ex: air tools) **DO NOT REMOVE WHEN PRESSURIZED!**
- H. **DUMP INLET-** Install the 1/4" airline from the bottom of the water separator to this port.
- I. **DUMP EXHAUST-** Install 1/4" airline in this port and route toward the ground. (this will drain condensation from the water separator)
- J. **HYDRAULIC COMMUNICATION CONNECTOR-** Used only if application uses a Yetter Hydraulic Compressor (see page 29)

2940-103 Control Box Internal Lay Out

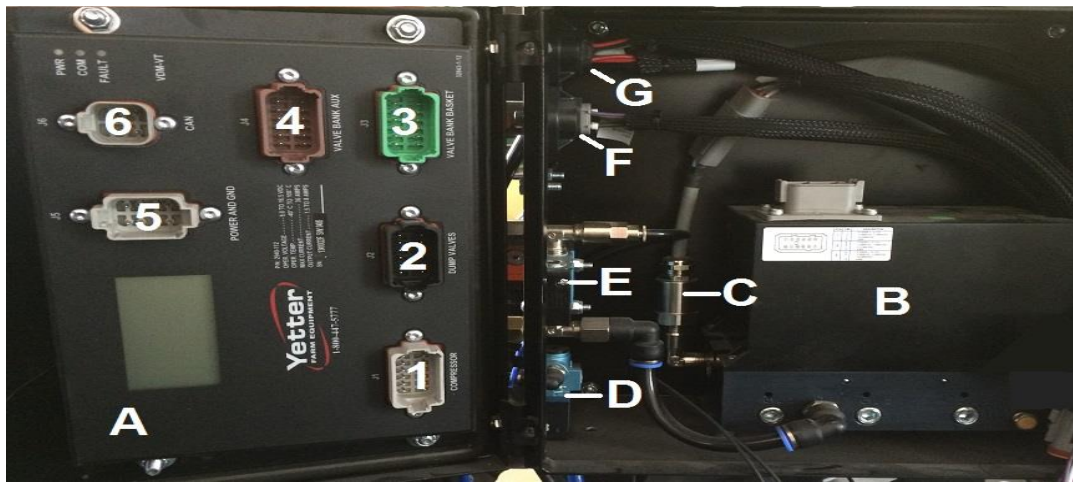

- | | | |
|--------------|----------------------------|------------------------------------|
| A. 2940-112 | VDM | 1. J1 Compressor Communication |
| | | 2. J2 Dump Valve Communication |
| | | 3. J3 PQE Communication |
| | | 4. J4 Plugged (not used) |
| | | 5. J5 VDM Power and Ground |
| | | 6. J6 Cab Controller Communication |
| B. 2940-402 | PQE | |
| C. 2940-441 | Pressure Transducer | |
| D. 2940-336 | Water Separator Dump Valve | |
| E. 2940-135 | Pressure On Valve | |
| F. no part # | Dump Valve Power Harness | |
| G. no part # | Can Aux Power Harness | |

Residue Manager



Each kit will include the required brackets and hardware to mount the residue managers or residue manager/coulter combo

RM/Coulter Combo



Harness, Airlines, and Fittings Kit



12V-DC cables will be used to power VDM, cab controller, and dump valves. Flexible tubing will be used to move air from the tank to each air bag. Each kit will include pneumatic lines for both circuits, down and lift, as well as the fittings to make connections and cable ties to securely fasten the lines to the planter. Note: All 2940 Air Adjust kit include a tubing cutter within the kit. **The 2940-341 cutter should be used for every cut to ensure a clean, square cut.**



Installation Guide Using a Yetter Hydraulic Compressor

For installation using a John Deere Hydraulic Compressor installation, see page 17.

For installation using a Precision Planting Hydraulic Compressor, see page 18.

STEP 1: RESIDUE MANAGER OR COULTER/RESIDUE MANAGER COMBO INSTALLATION

Install the Residue Manager Assembly securing with 2940-142 mounting hardware. When installing the 2940-215 or 2940-216 wheel mount assembly on the adjustment tube of the 2940-190, place the top whole of the wheel mount to the 4th or 5th hole from the top of the adjustment tube for conventional tillage or mellow soils. For no/minimum till operations, install the wheel mount on the 5th or 6th hole from the top. Install wheels on wheel mounts using the 2966-119 bolt bag. If application is RM/Coulter combo, install the 2940-191 assembly using the 2940-187 bolt bag. Mount the coulter blade on the coulter arm hub, mount the coulter arm to the 2940-191 assembly, and mount the RM wheels using the 2966-119 bolt bag **Refer to the diagram on pages 19-22**

STEP 2: INSTALLING 2940-100 CAB CONTROLLER

Mount the 2940-100 Cab Controller and 2940-133 RAM Mount within the tractor cab. Position the Cab Controller within reach during operation without compromising safety or visibility from the cab. Connect the 2940-152 harness to the female 6 pin connector on the back of the cab controller and route the black CAN connector towards the hitch of the tractor. Connect the 2940-153 2 pin connector to the female 2 pin connector on the back cab controller and the red and black wires to the appropriate connector to fit the tractor's switched power source. **Refer to the diagram on pages 23**

STEP 3: HYDRAULIC COMPRESSOR AND CONTROL BOX INSTALLATION

Remove the hydraulic compressor from the shipping crate, remove the cap from the elbow fitting, and install the air filter assembly securely. Remove the screen on the housing on the side with the sight glass (same side as pressure gauge) and fill compressor pump with provided oil until oil is in middle of sight glass. Locate a suitable mounting location for the compressor assembly. Placement of the compressor assembly will vary on the make and model of the planter. Use mounts supplied or depending on application, **different mounts may need to be built**. Be sure to check clearance of compressor assembly in mounting location, noting tractor tires while making turns and folding/unfolding planter. Mount the 2940-103 in a safe location with mounts supplied. Install the 2940-415 water separator/regulator assembly near the 2940-103 control box. Measure and cut the 2940-367 250psi rated 3/8" airline and install from output elbow on the Yetter hydraulic compressor into the 2940-415 input. The regulator is preset to only allow 120psi of dry clean air beyond it. Route 2940-345 3/8" airline from the 2940-415 output (regulator side) to 2940-103 inlet. Route provided 1/4" airline from the elbow on the bottom of the 2940-415 to one of the 1/4" PTC fittings on the side of the 2940-103. (doesn't matter which one) Route 1/4" airline from remaining 1/4" PTC fitting on the 2940-103 toward the ground, as this airline will dispense moisture. **Refer to the diagram on pages 24-27**

STEP 4: COMPRESSOR AND CONTROL BOX HARNESS ROUTING AND INSTALLATION

Install the 2940-166 VDM power with 40 amp breaker on the correct battery terminals, red is positive+ and black is negative -. Connect the VDM power extension and route to the hitch of the tractor. Install the CAN Aux To Air Harness, 2940-164 or 2940-165. The Anderson power connector connects to the VDM power extension, the black CAN connector connects to the 2940-152 black CAN connector that routes and plugs into the cab controller, and the black male 12 pin Deutsch connector connects to the black female end on the side of the 2940-103 assembly housing. 2940-170, 2940-171, or 2940-430 CAN Aux To Air Extensions may be necessary if the 2940-103 is mounted further back on the planter than the hitch. . Install the 2940-181 Y harness on the hydraulic compressor and the 2940-182 or 2940-189 communication harness from the 4 pin end of the 2940-181 Y harness to the 4 pin pigtail coming out of the 2940-103. **Refer to the diagram on pages 28-29**

STEP 5: DUMP VALVE AND DUMP VALVE HARNESS INSTALLATION

Install the dump valves to the planter as shown in the diagram that matches the planter. 16 row planters and less will have 1 up pressure and 1 down pressure dump valve on each wing/side and 1 up pressure and 1 down pressure dump valve on the wheel track(WT) rows. 24 row planters and larger will have 3 dump valves per wing/side, 2 down pressure and 1 up pressure, and 2 dump valves on the WT rows, 1 up pressure and 1 down pressure. Split row planters will vary. Install the gray male 12 pin Deutsch connector of the 2940-162 into the gray female 12 pin Deutsch on the 2940-103. The 2940-162 will have 4) 2 pin pig tails. The connector labeled RM Up Dump will connect to all up pressure dump valves using 2940-155, 2940-157, 2940-160 white dump valve harnesses and, if necessary, multiple 2940-159 white Y harnesses. The connector labeled RM Down Dump will connect to all down pressure dump valves using 2940-154, 2940-156, 2940-161 black dump valve harnesses and multiple 2940-158 black Y harness. **CONNECTORS LABELED AUX 3 AND AUX 4 WILL NOT BE USED!** **Refer to page 30**

STEP 6: PLUMBING AIR LINES

Start by routing black (down pressure) and blue (up pressure) airline on each wing/side of the planter. A group of airlines that route to the row cleaner air bags are referred to as trunk lines. When plumbing in the WT (wheel track) rows, use the center 6 rows that plant over the tractor and planter wheel tracks. If equipping on a narrow transport planter with 4 center rows, tie in the one row on each wing/side of the planter closest to the first & last center row. The airline routing from the RU, RD, & WT to the inlet of the dump valve for the matching circuit is referred to as a Supply airline. Use the supplied tees to make enough open ports in each circuit to install supply airline to the inlet port of each dump valve of the matching circuit. Also use tees to connect the outlet port of the dump valves to the matching circuits of the trunk airlines. **Refer to pages 31-64**

STEP 7: PERFORM A PRE-OP TEST OF THE SYSTEM

Now that the system is installed, perform a pre-operation test. Start by folding & unfolding and lowering & raising the planter to check for enough slack in airline & in harnesses at hinge points. Check all electrical connections, cables, and airline making sure nothing was damaged. Next, turn on the cab controller by holding the power button. After the cab controller is on, turn all pressures (RU, RD, and WT) to 0psi and press enter to actuate the system. The compressor will turn on and build to 145psi (120psi on the cab controller) and turn off. Check the interior of the 2940-103 control box housing (PQE, Pressure on Valve, & airline within the housing) for leaks. Apply 30psi to the RU port and watch your row cleaners as they should all rise to maximum up travel. Check for leaks on all up pressure circuits and fittings. When that leak check is finished, turn RU to 0psi & turn RD and WT to 30. Check all down pressure airline and fittings in these circuits for leaks and repair as needed.

Refer to page 71-72

Installation Guide for John Deere Hydraulic Compressor

STEP 1: RESIDUE MANAGER OR COULTER/RESIDUE MANAGER COMBO INSTALLATION

Install the Residue Manager Assembly securing with 2940-142 mounting hardware. When installing the 2940-215 or 2940-216 wheel mount assembly on the adjustment tube of the 2940-190, place the top whole of the wheel mount to the 4th or 5th hole from the top of the adjustment tube for conventional tillage or mellow soils. For no/minimum till operations, install the wheel mount on the 5th or 6th hole from the top. Install wheels on wheel mounts using the 2966-119 bolt bag. If application is RM/Coulter combo, install the 2940-191 assembly using the 2940-187 bolt bag. Mount the coulter blade on the coulter arm hub, mount the coulter arm to the 2940-191 assembly, and mount the RM wheels using the 2966-119 bolt bag **Refer to the diagram on pages 19-22**

STEP 2: INSTALLING 2940-100 CAB CONTROLLER

Mount the 2940-100 Cab Controller and 2940-133 RAM Mount within the tractor cab. Position the Cab Controller within reach during operation without compromising safety or visibility from the cab. Connect the 2940-152 harness to the female 6 pin connector on the back of the cab controller and route the black CAN connector towards the hitch of the tractor. Connect the 2940-153 2 pin connector to the 2 pin female end of the cab controller and the red and black wires to the appropriate terminals on the connector to fit the tractor's switched power source. **Refer to the diagram on pages 23**

STEP 3: 2940-103 CONTROL BOX INSTALLATION

Mount the 2940-103 in a safe location with mounts supplied. Locate the John Deere hydraulic compressor and its pneumatic valve block assembly. Drain all air pressure from the John Deere hydraulic compressor tank and valve block. To the left of the yellow valve handle on the valve block is a pipe plug or gauge. Remove the pipe plug if equipped and install a 2940-408 ¼"NPT to 3/8 push to connect (PTC) elbow in that port. If equipped with a gauge, remove gauge and install 2940-374 adaptor with 2 female ¼"NPT ends and 1 male ¼"NPT end. Male thread side of the Tee installs into valve block, the gauge installs onto the rearward facing female threads, and the 2940-408 elbow into the remaining female threads. Apply Teflon tape to all male threads. Mount the 2940-415 water separator/regulator assembly near the 2940-103. Measure and cut 2940-367 250psi rated line from the 2940-408 elbow attached to the John Deere Compressor into the inlet of the 2940-415 assembly. The regulator is preset to only allow 120psi of dry clean air beyond it. Measure and cut 2940-345 black air line from the outlet (regulator side) of the 2940-415 assembly to the inlet of the 2940-103. Route provided ¼" airline from the elbow on the bottom of the 2940-415 to one of the ¼"PTC fittings on the side of the 2940-103. (doesn't matter which fitting) Route ¼" airline from remaining ¼"PTC fitting on the 2940-103 toward the ground, as this airline will dispense moisture. **Refer to the diagram on pages 27**

STEP 4: HARNESS ROUTING AND INSTALLATION

Install the 2940-166 VDM power with 40 amp breaker on the correct battery terminals, red is positive+ and black is negative -. Connect the VDM power extension and route to the hitch of the tractor. Install the CAN Aux To Air Harness, 2940-164 or 2940-165. The Anderson power connector connects to the VDM power extension, the black CAN connector connects to the 2940-152 black CAN connector that routes and plugs into the cab controller, and the black male 12 pin Deutsch connector connects to the black female end on the side of the 2940-103 assembly housing. 2940-170, 2940-171, or 2940-430 CAN Aux to Air Extensions may be necessary if the 2940-103 is mounted further back on the planter than the hitch. **Refer to the diagram on pages 28-29**

STEP 5: DUMP VALVE AND DUMP VALVE HARNESS INSTALLATION

Install the dump valves to the planter as shown in the diagram that matches the planter. 16 row planters and less will have 1 up pressure and 1 down pressure dump valve on each wing/side and 1 up pressure and 1 down pressure dump valve on the wheel track(WT) rows. 24 row planters and larger will have 3 dump valves per wing/side, 2 down pressure and 1 up pressure, and 2 dump valves on the WT rows, 1 up pressure and 1 down pressure. Split row planters will vary. Install the gray male 12 pin Deutsch connector of the 2940-162 into the gray female 12 pin Deutsch on the 2940-103. The 2940-162 will have 4) 2 pin pig tails. The connector labeled RM Up Dump will connect to all up pressure dump valves using 2940-155, 2940-157, 2940-160 white dump valve harnesses and multiple 2940-159 white Y harnesses. The connector labeled RM Down Dump will connect to all down pressure dump valves using 2940-154, 2940-156, 2940-161 black dump valve harnesses and multiple 2940-158 black Y harness. **CONNECTORS LABELED AUX 3 AND AUX 4 WILL NOT BE USED! Refer to page 30-64**

STEP 6: PLUMBING AIR LINES

Start by routing black (down pressure) and blue (up pressure) airline on each wing or side of the planter. A group of airlines that route to the row cleaner air bags are referred to as trunk lines. When plumbing in the WT (wheel track) rows, use the center 6 rows that plant over the tractor and planter wheel tracks. If equipping on a narrow transport planter with 4 center rows, tie in the one row on each wing/side of the planter closest to the last & first center row. The airline routing from the RU, RD, & WT to the inlet of the dump valve for the matching circuit is referred to as a Supply airline. Use the supplied tees to make enough open ports in each circuit to install supply airline to the inlet port of each dump valve of the matching circuit. Also use tees to connect the outlet port of the dump valves to the matching circuits of the trunk airlines. **Refer to pages 31-64**

STEP 7: PERFORM A PRE-OP TEST OF THE SYSTEM

Now that the system is installed, perform a pre-operation test. Start by folding & unfolding and lowering & raising the planter to check for enough slack in airline & in harnesses at hinge points. Check all electrical connections, cables, and airline making sure nothing was damaged. Next, turn on the cab controller by holding the power button. After the cab controller is on, turn all pressures (RU, RD, and WT) to 0psi and press enter to actuate the system. The compressor will turn on and build to 145psi (120psi on the cab controller) and turn off. Check the interior of the 2940-103 control box housing (PQE, Pressure on Valve, & airline within the housing) for leaks. Apply 30psi to the RU port and watch your row cleaners as they should all rise to maximum up travel. Check for leaks on all up pressure circuits and fittings. When that leak check is finished, turn RU to 0psi & turn RD and WT to 30. Check all down pressure airline and fittings in these circuits for leaks and repair as needed. **Refer to page 71-72**

Installation Guide for Precision Planting Hydraulic Compressor

STEP 1: RESIDUE MANAGER OR COULTER/RESIDUE MANAGER COMBO INSTALLATION

Install the Residue Manager Assembly securing with 2940-142 mounting hardware. When installing the 2940-215 or 2940-216 wheel mount assembly on the adjustment tube of the 2940-190, place the top whole of the wheel mount to the 4th or 5th hole from the top of the adjustment tube for conventional tillage or mellow soils. For no/minimum till operations, install the wheel mount on the 5th or 6th hole from the top. Install wheels on wheel mounts using the 2966-119 bolt bag. If application is RM/Coulter combo, install the 2940-191 assembly using the 2940-187 bolt bag. Mount the coulter blade on the coulter arm hub, mount the coulter arm to the 2940-191 assembly, and mount the RM wheels using the 2966-119 bolt bag **Refer to the diagram on pages 19-22**

STEP 2: INSTALLING 2940-100 CAB CONTROLLER

Mount the 2940-100 Cab Controller and 2940-133 RAM Mount within the tractor cab. Position the Cab Controller within reach during operation without compromising safety or visibility from the cab. Connect the 2940-152 harness to the female 6 pin connector on the back of the cab controller and route the black CAN connector towards the hitch of the tractor. Connect the 2940-153 2 pin connector to 2 pin female end of the cab controller and the red and black wires to the appropriate terminals on the connector to fit the tractor's switched power source. **Refer to the diagram on pages 23**

STEP 3: 2940-103 CONTROL BOX INSTALLATION

Mount the 2940-103 in a safe location with mounts supplied. Mount the 2940-415 water separator/regulator assembly near the 2940-103. Locate the Precision Planting compressor, drain all tank pressure, and find the 3/8 tubing inside the housing that routes between the tank and the water separator. Cut and Tee into that line. Measure and cut 2940-367 250psi rated line and route from remaining port on the Tee to the inlet of the Yetter 2940-415 water separator/regulator assembly. The regulator is preset to only allow 120psi of dry clean air beyond it. Measure and cut 2940-345 black air line from the outlet (regulator side) of the 2940-415 assembly to the inlet of the 2940-103. Route provided 1/4" airline from the elbow on the bottom of the 2940-415 to one of the 1/4"PTC fittings on the side of the 2940-103. (doesn't matter which fitting) Route 1/4" airline from remaining 1/4"PTC fitting on the 2940-103 toward the ground, as this airline will dispense moisture. **Refer to the diagram on pages 27**

STEP 4: HARNESS ROUTING AND INSTALLATION

Install the 2940-166 VDM power with 40 amp breaker on the correct battery terminals, red is positive+ and black is negative -. Connect the VDM power extension and route to the hitch of the tractor. Install the CAN Aux To Air Harness, 2940-164 or 2940-165. The Anderson power connector connects to the VDM power extension, the black CAN connector connects to the 2940-152 black CAN connector that routes and plugs into the cab controller, and the black male 12 pin Deutsch connector connects to the black female end on the side of the 2940-103 assembly housing. 2940-170, 2940-171, or 2940-430 CAN Aux to Air Extensions may be necessary if the 2940-103 is mounted further back on the planter than the hitch. **Refer to the diagram on pages 28-29**

STEP 5: DUMP VALVE AND DUMP VALVE HARNESS INSTALLATION

Install the dump valves to the planter as shown in the diagram that matches the planter. 16 row planters and less will have 1 up pressure and 1 down pressure dump valve on each wing/side and 1 up pressure and 1 down pressure dump valve on the wheel track(WT) rows. 24 row planters and larger will have 3 dump valves per wing/side, 2 down pressure and 1 up pressure, and 2 dump valves on the WT rows, 1 up pressure and 1 down pressure. Split row planters will vary. Install the gray male 12 pin Deutsch connector of the 2940-162 into the gray female 12 pin Deutsch on the 2940-103. The 2940-162 will have 4) 2 pin pig tails. The connector labeled RM Up Dump will connect to all up pressure dump valves using 2940-155, 2940-157, 2940-160 white dump valve harnesses and multiple 2940-159 white Y harnesses. The connector labeled RM Down Dump will connect to all down pressure dump valves using 2940-154, 2940-156, 2940-161 black dump valve harnesses and multiple 2940-158 black Y harness. **CONNECTORS LABELED AUX 3 AND AUX 4 WILL NOT BE USED! Refer to page 30-64**

STEP 6: PLUMBING AIR LINES

Start by routing black (down pressure) and blue (up pressure) airline on each wing or side of the planter. A group of airlines that route to the row cleaner air bags are referred to as trunk lines. When plumbing in the WT (wheel track) rows, use the center 6 rows that plant over the tractor and planter wheel tracks. If equipping on a narrow transport planter with 4 center rows, tie in the one row on each wing/side of the planter closest to the last & first center row. The airline routing from the RU, RD, & WT to the inlet of the dump valve for the matching circuit is referred to as a Supply airline. Use the supplied tees to make enough open ports in each circuit to install supply airline to the inlet port of each dump valve of the matching circuit. Also use tees to connect the outlet port of the dump valves to the matching circuits of the trunk airlines. **Refer to pages 31-64**

STEP 7: PERFORM A PRE-OP TEST OF THE SYSTEM

Now that the system is installed, perform a pre-operation test. Start by folding & unfolding and lowering & raising the planter to check for enough slack in airline & in harnesses at hinge points. Check all electrical connections, cables, and airline making sure nothing was damaged. Next, turn on the cab controller by holding the power button. After the cab controller is on, turn all pressures (RU, RD, and WT) to 0psi and press enter to actuate the system. The compressor will turn on and build to 145psi (120psi on the cab controller) and turn off. Check the interior of the 2940-103 control box housing (PQE, Pressure on Valve, & airline within the housing) for leaks. Apply 30psi to the RU port and watch your row cleaners as they should all rise to maximum up travel. Check for leaks on all up pressure circuits and fittings. When that leak check is finished, turn RU to 0psi & turn RD and WT to 30. Check all down pressure airline and fittings in these circuits for leaks and repair as needed. **Refer to page 71-72**

Residue Manager(RM) Installation



ENGAGE THE CYLINDER STOPS ON THE PLANTER LIFT WHEELS TO “LOCK” THE PLANTER IN THE UP POSITION

Installation overview:

- Prior to installing check the freedom of motion of the row cleaner.
- The installation process should be done with the planter raised, half folded for transport, and the row units fully extended down.
- Install the 2940 RM or RM/Coulter Combo Mounting Bracket Assembly centered on the planter row unit with provided hardware.
- If planter is made by John Deere and equipped with HD scrapers on the True V opener blades, a 2940-049 kit will need installed to space the 2940-190 RM or 2940-191 RM/Coulter Combo out to avoid interference.

For John Deere, Kinze, and White Models Installing RM Only

Step 1: Mount the 2940-190 Pneumatic RM mount assembly using 3) 1/2"X1-1/2" GR5 bolts, 3) 1/2" flat washers, and 3) 1/2" lock nuts. Use diagram below for hole alignment.

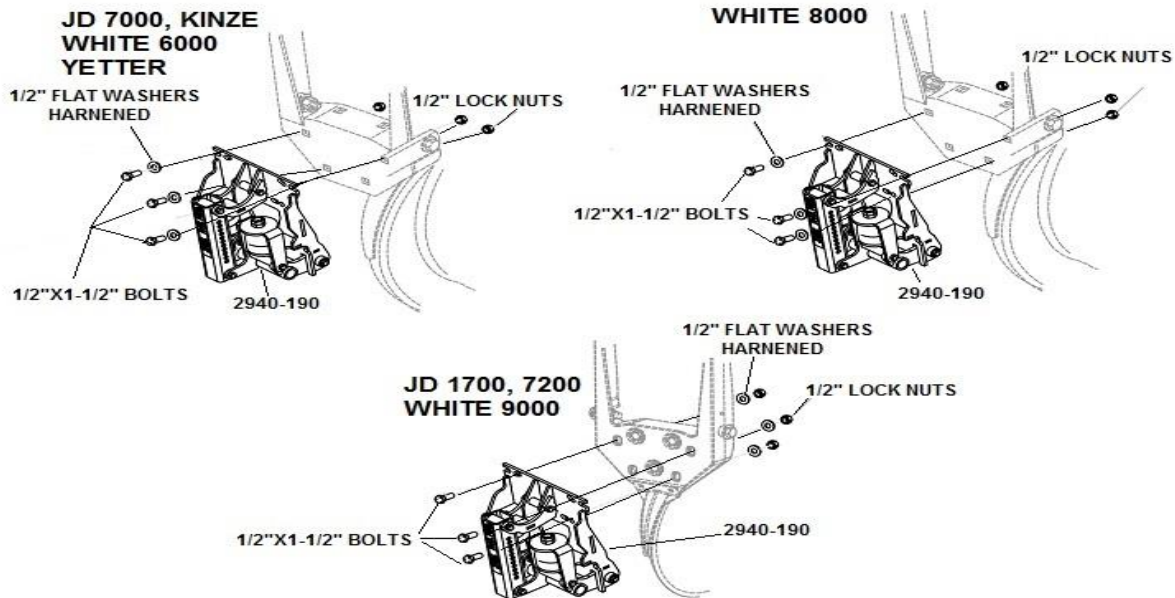

For Case Models Installing RM Only

Step 1: Mount the 2940-209 CNH adaptor bracket to the row unit attachment casting using 2) 1/2"X3-3/4" bolts and 2) 1/2" lock nuts. Attach the 2940-190 to the 2940-209 using 3) 1/2"X1-1/2"GR5 bolts, 3) 1/2" flat washers, and 3) 1/2" lock nuts.

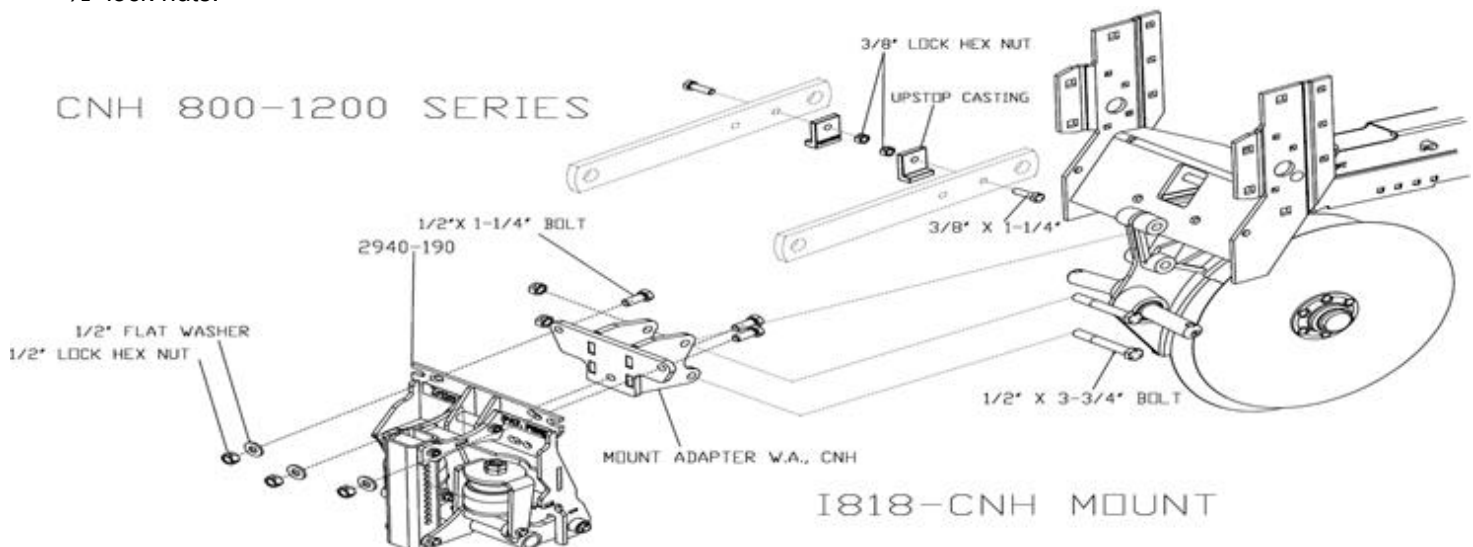

Residue Manager Installation Con't

Step 2: Mount the 2940-215 or 2940-216 wheel mount W.A. on the adjustment tube of the 2940-190. Recommended mounting location is 5th hole down from the top of the adjustment tube mounts to the top hole of the wheel mount W.A. Adjustments may need to be made depending on tillage practice, soil conditions, and/or residue thickness.

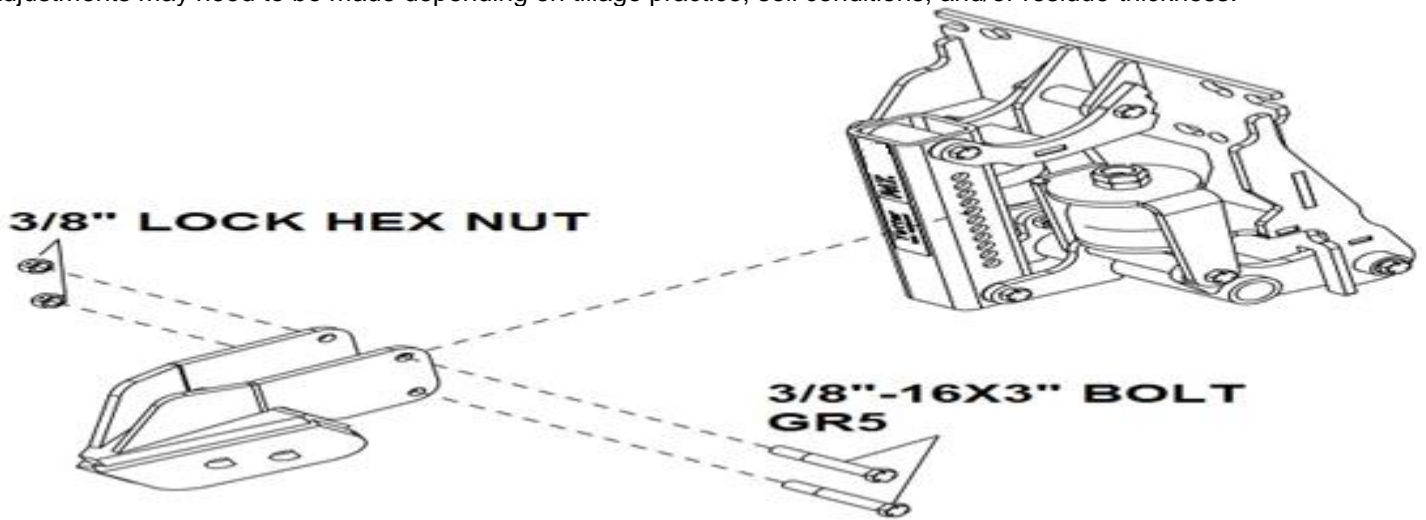

Step 3: Mount the RM wheels on the wheel mount using 2) 5/8" lock washer and 2) 5/8 hex nut. Mount the wheels so the left side of the planters has the left wheel leading and the right side of the planter has the right wheel leading. Right and left is determined by standing behind the planter looking at the tractor or sitting in the tractor facing forward.

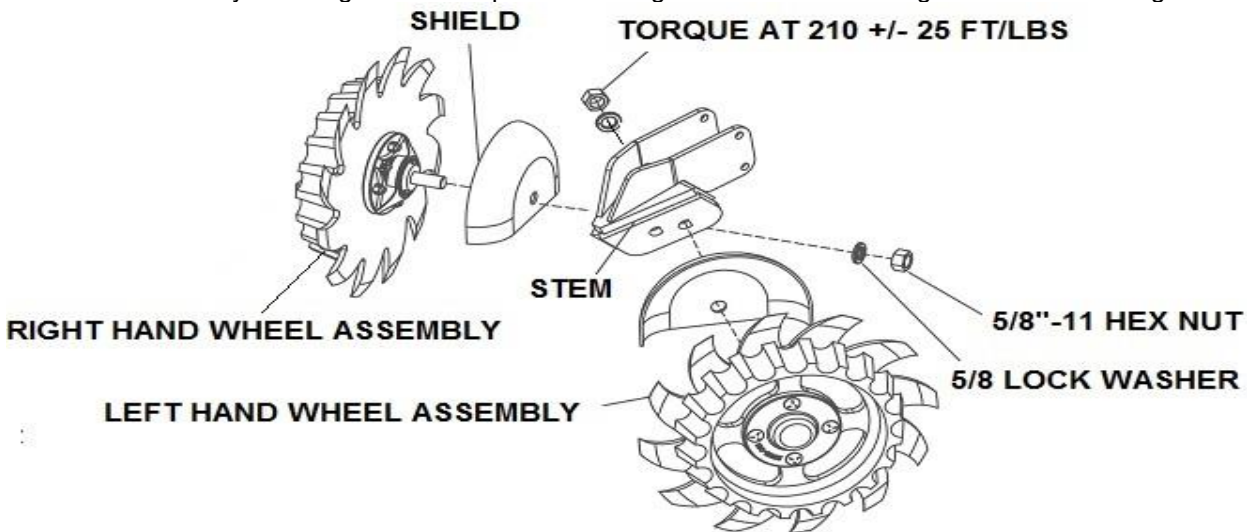

1818-D-BOLT TORQUE

Note: Properly install row cleaner wheels so that wheel teeth curve back when entering field debris.

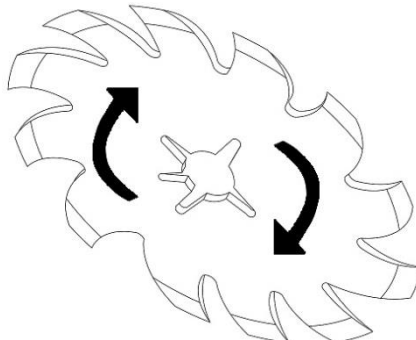

2940-010 RM/Coulter Combo Installation

Step 1: Mount the 2940-191 assembly to the row unit face plate using 3) 1/2"X1 1/2 bolts and 3) 1/2" lock nuts.

1/2" BOLTS AND 1/2" LOCK NUTS ARE USED TO MOUNT TO ROW UNIT



Step 2: Make sure elbows swivel by placing 11/16" wrench on NPT end and turning elbow by hand a few rotations. Once fittings are started on the air bag, tighten until thread tape almost disappears. **OVER TIGHTENING WILL STRIP THREADS & CAUSE AIR LEAK!**

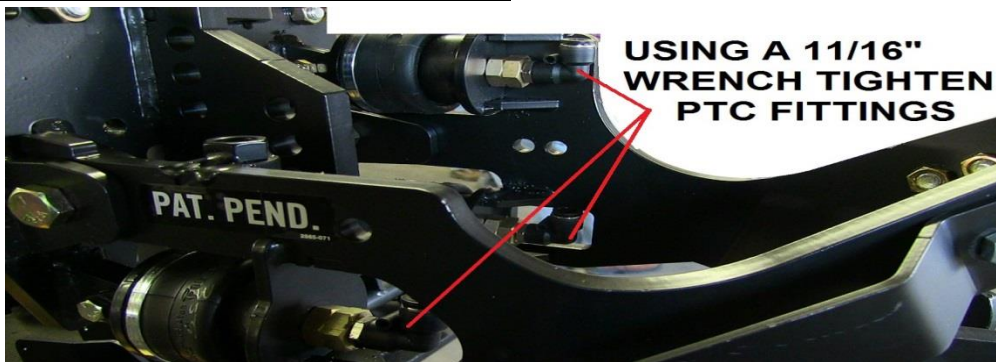

Step 3: Install coultter blade using 4) 1/2"X1 1/4" carriage bolts. The blade **MUST** be installed on the hub before mounting the coultter arm assembly. **IF USING SETTING #2 ON CHART ON PAGE 20 FOR COULTTER DEPTH, LEAVE THE BLADE LOOSE ON THE HUB IN ORDER TO INSTALL COULTTER ARM. DOING SO ALLOWS THE COULTTER ARM MOUNTING BOLT CLOSEST TO THE HUB TO BE INSERTED IN STEP 4 WITHOUT CLEARANCE ISSUES.**

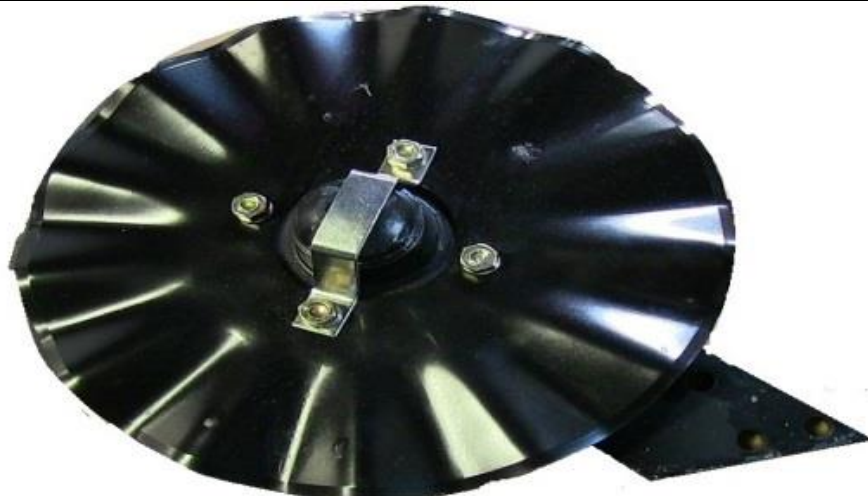

ASSEMBLE BLADE AND HUB RETAINER TO HUB USING 1/2" CARRIAGE BOLTS, LOCK WASHERS, AND HEX NUTS

2940-010 RM/Coulter Combo Installation Con't

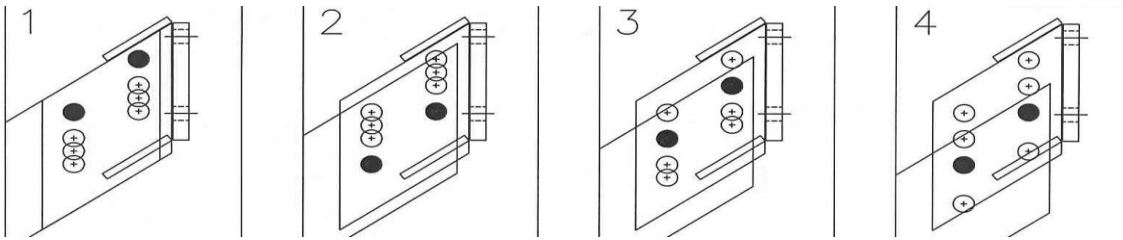

NOTE: THIS IS A REFERENCE GUIDE TABLE. ALL MEASUREMENTS WERE TAKEN WITH THE ROW UNIT AND PLANTER FRAME LEVEL/PARALLEL TO THE SURFACE.

USING A 16" COULTER BLADE

15" PLANTER BLADES	15" PLANTER BLADES
JD 7000 AND KINZE PLANTERS	JD 1700, 7200, & 7300 PLANTERS
ALL WHITE 6000 PLANTERS	PRO AND PLUS SERIES
BOLT POSITION #	BOLT POSITION #
1) 1-1/2" ABOVE SEED DEPTH	1" ABOVE SEED DEPTH
2) 1" ABOVE SEED DEPTH	2) 5/8" ABOVE SEED DEPTH
3) 1/2" ABOVE SEED DEPTH	3) EVEN WITH SEED DEPTH
4) 1/2" BELOW SEED DEPTH	4) 7/8" BELOW SEED DEPTH

STEP 4: Install coulter and arm assembly in desired setting using 2) 5/8"x2" bolts and 2) 5/8" hex jam locknuts. Pull arm up when tightening to allow more space between coulter blade and disc opening blades.

MOUNT COULTER ARM USING 5/8 BOLTS AND NUTS.

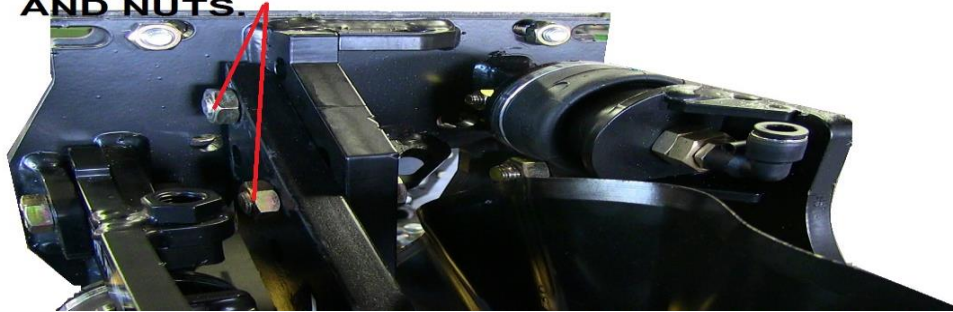

Adjustment: Adjust coulter blade depth equal to or above the planter opener blades. Adjust the blade depth as required for blade wear. Planter double disc blades that are worn to 14 1/4" or smaller in diameter should be replaced. Example: 14 1/4" blades will have a 3/8" shallower planting depth than 15" blades at the same gauge wheel adjustment setting.

STEP 5: Install 5/8" jam nut on the 5/8"x3" square head down stop bolt. Set down stop to desired setting, then tighten jam nut to hold stop bolt in place.

INSTALL DOWN STOP BOLT AND JAM NUT AT DESIRED DEPTH

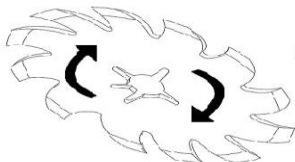
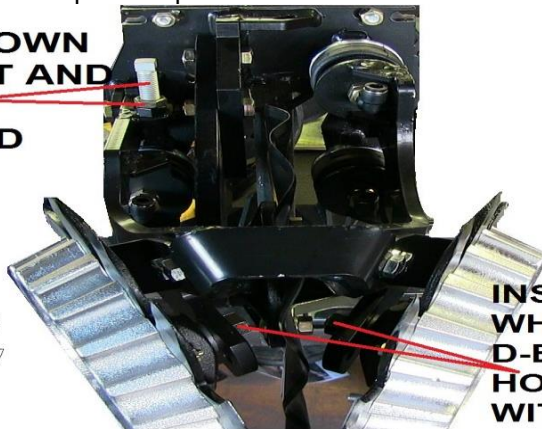

INSTALL ROW CLEANER WHEELS BY INSERTING D-BOLT THROUGH REAR HOLES AND SECURE WITH 5/8 WHIZ LOK NUT

STEP 6: Install RM wheels by sliding 5/8" D-bolts through the rear mounting holes on each side of the arm. Install the row cleaner wheels so that wheel's teeth curve back when entering field debris.

Cab Controller Installation



Step 1: Begin installing the 2940 Air Adjust controller once an adequate mounting location has been found. Fix the base component of the 2940-113 Mounting Bracket in place. Use items labeled B if mounting to a slotted flat mounting system or items C if using a tubular mounting system. 2 different sized U-bolts are provided for tubular mounting systems.

Step 2: Connect the mount bracket to the rear of the controller using 4) M5 Hex Nut and 4) M5 split washers labeled A in picture above.

Step 3: Attach the male end 2 pin connector of the 2940-153 to the female end 2 pin connector on the 2940-100 cab controller. Install connector not provided for your tractor at the bare end of the 2940-153 and connect to tractors switched power source. **The cigarette outlet is NOT a switched port on all models of tractors, and therefore should not be used.**

Switched Power Source Connector part #'s:

JOHN DEERE PART #: RE67013

CNH PART #: 187103A1



Step 4: Route & install the 2940-152 hitch to switch panel wire harness from the rear 6 pin connector of the 2940-100 cab controller to the hitch-point at the rear of the tractor. The black CAN connector of the 2940-152 will connect to the 2940-164 or 2940-165 CAN Aux to Air Harness. **(See page 29 for further details)**



Yetter Hydraulic Compressor Installation

Step 1: Preparation

The crate labeled 2940-055 should include the 2940-106 Yetter hydraulic compressor, 1 liter bottle of oil, Manual, 2940-181 hydraulic compressor solenoid/pressure switch harness, 2940-189 10' hydraulic communication harness, & air filter assembly. Remove the compressor from the crate, remove the housing by removing 6 bolts, 4 are pictured in picture 1 below, the other 2 are on the opposite side of the housing, using a 7/16 socket & wrench. Remove dipstick and fill pump with provided oil until oil reaches fill line on the sight glass. Reinstall the housing & remove the red dust cap on the elbow on top of the compressor housing. Wrap the male threads on the air filter assembly with Teflon tape & securely install the air filter assembly on the elbow.

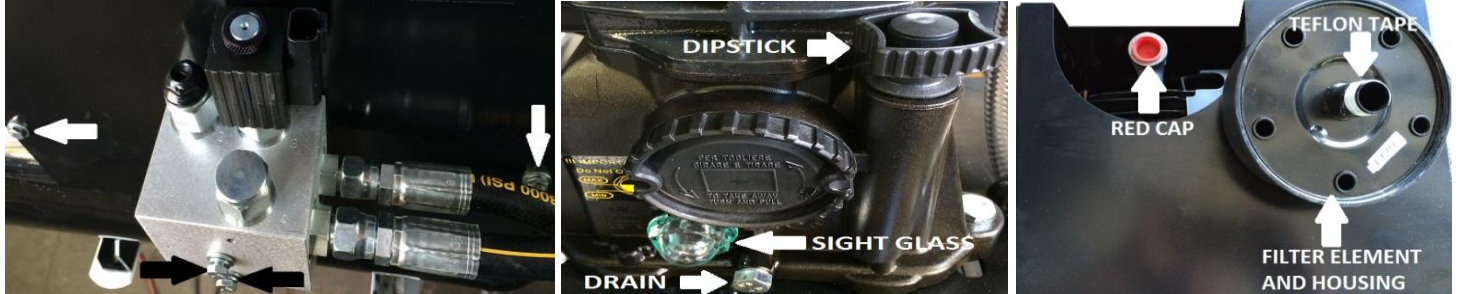

Step 2: Mounting

Every planter/tractor combination will contain its own unique situations in regard to mounting the 2940 Hydraulic Compressor assembly for clearance & accessibility. **YOU SHOULD EXERCISE YOUR OWN BEST JUDGEMENT TO FIT YOUR SITUATION.** Begin by locating a suitable mounting location. Placement will vary on the make & model of the planter. Use mounts supplied or **depending on application different mounts may need to be built, see examples below labeled customer built bracket.** Be sure to check clearance in all locations, especially noting tractor tires, folding/unfolding the planter for transport mode, marker arms, fertilizer tanks, & 2-point top link. Yetter has 4 different mounting kits, the 2940-085 to mount the compressor to the top link of the 2 point hitch, 2940-086 to mount to the draft tube, 2940-090 to mount to an 8inch X 12inch bar, & a 2940-091 to mount to an 8inch X 16inch bar. A process of folding/unfolding, turning in a tight circle, and raising/lowering markers & planter is recommended to ensure compressor clearance.

2940-085



2940-086



2940-090 & 2940-091



CUSTOMER BUILT BRACKET



CUSTOMER BUILT BRACKET



Yetter Hydraulic Compressor Installation

Step 3: Hydraulic Connection

Tying into a planter hydraulic circuit or tying into an open SCV port on the tractor are the 2 ways to operate the hydraulic compressor. **Hydraulic PTO driven circuits are not capable of producing the capacity to handle the Yetter hydraulic compressor.** The Yetter hydraulic compressor requires 4 gallons per minute max. The 2940-088 hydraulic fittings kit is used to tie into a planter circuit and 2940-089 hydraulic fittings kit is for using an open remote circuit on the tractor. In some applications, more fittings may need purchased to make the hydraulic connection. A case drain will also need to be connected. Case Drain is a pressure free circuit that provides a flow path to the reservoir for hydraulic fluid used to cool and lubricate the motor. Make sure to connect the case drain to the reservoir where the hydraulic flow to the compressor is received. If tractor isn't equipped with case drain, a kit may be purchased from OEM tractor dealer. Below are a few examples of hydraulic connection.

TEEING IN THE BLOWER CIRCUIT OR LIFT/LOWER CIRCUIT AT THE BULKHEAD



TEEING BEHIND PIONEER COUPLER

SCV DIRECT

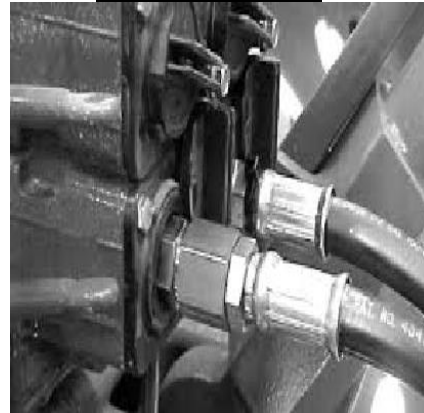

CASE DRAIN

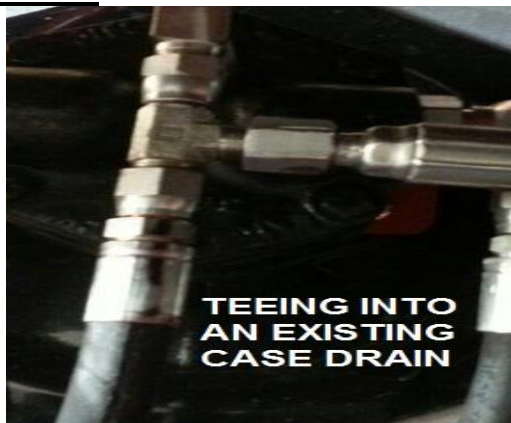
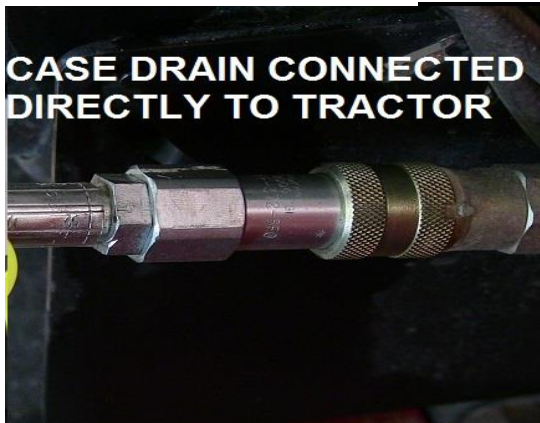

NOTE: THESE ARE EXAMPLES ONLY. USE YOUR BEST JUDGEMENT TO FIT YOUR SITUATION

Yetter Hydraulic Compressor Installation

Hose and Fitting Kits

All fittings & adaptors do not have to be used

2940-088 (PLANTER)	2940-089 kit (STAND ALONE)	Part #	Part Name	Description
Qty in kit	Qty in kit			
4	2	2515-324	ELBOW	90 DEG, 3/4 SAE TO -6 JIC
	2	2515-327	ADAPTER	3/4-16 SAE TO -6 JIC
3		2515-329	ADAPTER	REDUCER, -8 F TO -6 M JIC
2	2	2515-411	ELBOW	90 DEG 3/4 SAE TO -8JIC
3	1	2515-425	TEE	TEE 3/4 SAE
2		2515-428	ELBOW	JIC-6 90 DEGREE SWIVEL
3		2515-430	TEE	JIC-8 RUN TEE
2	2	2515-431	ADAPTER	9/16 SAE TO -6 JIC ADAPTER
1		2515-432	ELBOW	JIC-8 90 DEGREE SWIVEL
1	1	2515-433	ELBOW	9/16 SAE to -6 JIC 90 DEGREE
2	2	2515-831	HOSE	3/8 10FT HOSE -6 JIC F
1	1	2515-832	HOSE	1/2 10FT HOSE -8 JIC F
1	1	2515-833	ADAPTER	3/4 SAE TO -8 JIC
	2	2515-834	COUPLER	PIONEER, POPPET STYLE

2940-088 HOSE AND FITTING KIT (PLANTER)



2940-089 HOSE AND FITTING KIT (STAND ALONE)



2940-103 Control Box Installation

2940-103 Compressor Control Module is an assembled unit that utilizes compressed air supplied by the OEM hydraulic compressor to operate the 2940 Air Adjust System. In some situations, a mount may need to be built to install the 2940-103 in an adequate location. **OEM ELECTRIC COMPRESSORS ON PLANTERS WILL NOT OPERATE YETTER 2940 AIR ADJUST SYSTEMS!**

2940-103 MOUNTING GUIDE

2940-082 (See page 92 for diagram)

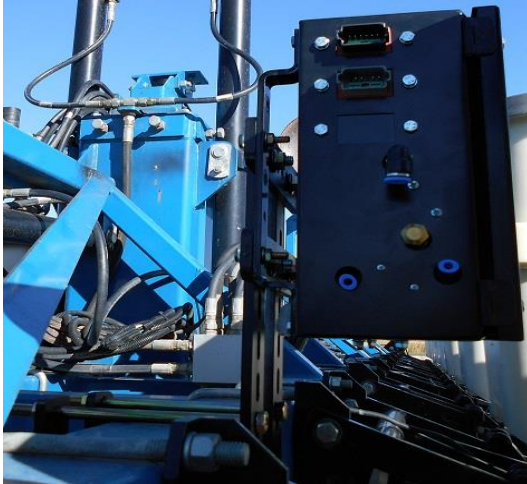

2940-083 (See page 93 for diagram)



2940-084(handrail by compressor)



2940-084(handrail between bulk fill tanks)



See page 94 for diagram of the 2940-084)

Water Separator/Regulator Installation

Install the 2940-415 assembly near the control box in a suitable location out of harm's way. The water separator removes moisture from entering the system's control box. The regulator is preset to only allow 120psi into the control box. Below are some examples of mounting locations for the water separator/regulator assembly.



Air Line Routing –Compressor to Control Box

If using a Yetter Hydraulic Compressor

Step 1: Route 2940-367 250psi rated 3/8" airline from the Yetter hydraulic compressor to the inlet port of the 2940-415 assembly. (labeled A)

Step 2: Route 2940-345 3/8" black airline from outlet port of 2940-415 (labeled B) to the inlet port (labeled 1) of the 2940-103.

Step 3: Route 1/4" airline from 1/4"PTC elbow (labeled C) on the 2940-415 to one of the 1/4"PTC fittings (labeled 2) on the side of the 2940-103. (doesn't matter which one)

Step 4: Route 1/4" airline from the remaining unused 1/4"PTC fitting on the side of the 2940-103 toward the ground making sure not pointed toward anything that moisture may damage or rust .

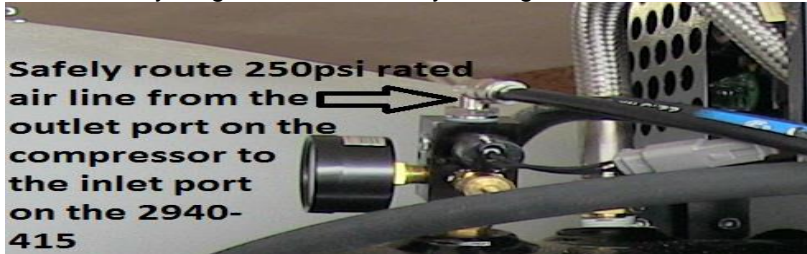

If using a John Deere Hydraulic Compressor

Step 1: Locate the valve block on the hydraulic compressor, drain air pressure, and remove gauge or pipe plug.

Step 2: If pipe plug equipped, install the 2940-408 3/8PTC 90 degree elbow where plug was removed. If gauge equipped, install the 2940-374 adaptor. Male end gets Teflon tape and installs on the hydraulic block, gauge installs in the rearward facing female end, and the 2940-408 3/8PTC 90 degree elbow installs in remaining end.

Step 3: Route 2940-367 250psi rated 3/8" airline from the 2940-408 to the inlet port of the 2940-415. (labeled A)

Step 4: Route 2940-345 black 3/8"airline from the outlet port (labeled B) of the 2940-415 to the inlet port (labeled 1) on the 2940-103.

Step 5: Route 1/4" airline from 1/4"PTC elbow (labeled C) on the 2940-415 to one of the 1/4"PTC fittings (labeled 2) on the side of the 2940-103. (doesn't matter which one)

Step 6: Route 1/4" airline from the remaining unused 1/4"PTC fitting on the side of the 2940-103 toward the ground making sure not pointed toward anything that moisture may damage or rust.

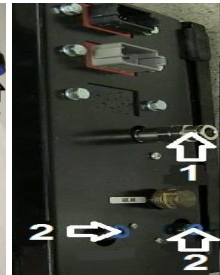

If using a Precision Planting Hydraulic Compressor

Step 1: Drain all tank pressure from the Precision Planting hydraulic compressor and install a Tee in the airline that routes from the top of the tank to the water separator. (as indicated by arrow below)

Step 2: Route 2940-367 250psi rated 3/8" airline from the installed Tee to the inlet of the 2940-415(labeled A)

Step 3: Route 2940-345 3/8" black airline from the outlet port on the 2940-415 (labeled B) to the inlet port (labeled 1) of the 2940-103 control box.

Step 4: Route 1/4" airline from 1/4"PTC elbow (labeled C) on the 2940-415 to one of the 1/4"PTC fittings (labeled 2) on the side of the 2940-103 (doesn't matter which one)

Step 5: Route 1/4" airline from the remaining unused 1/4"PTC fitting on the side of the 2940-103 toward the ground making sure not pointed toward anything that moisture may damage or rust

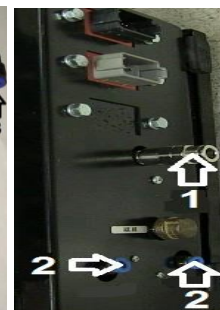
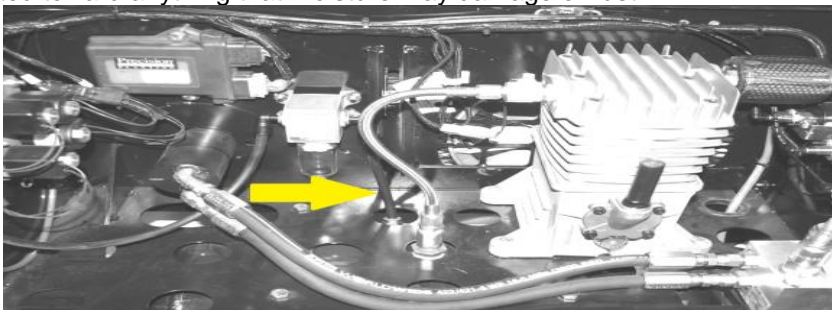

Control Box Harness Installation

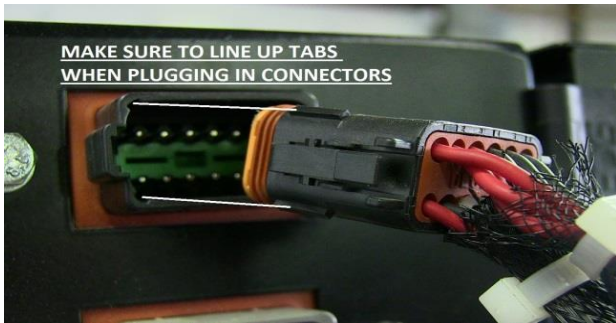

FAILURE TO LINE UP TABS WHEN PLUGGING MALE INTO FEMALE CONNECTORS CAN RESULT IN SHORT CIRCUIT. ALSO CHECK TAB AND SLOT SIZES, PLUGGING CONNECTORS IN BACKWARDS WILL RESULT IN FAULTY SYSTEM!!!

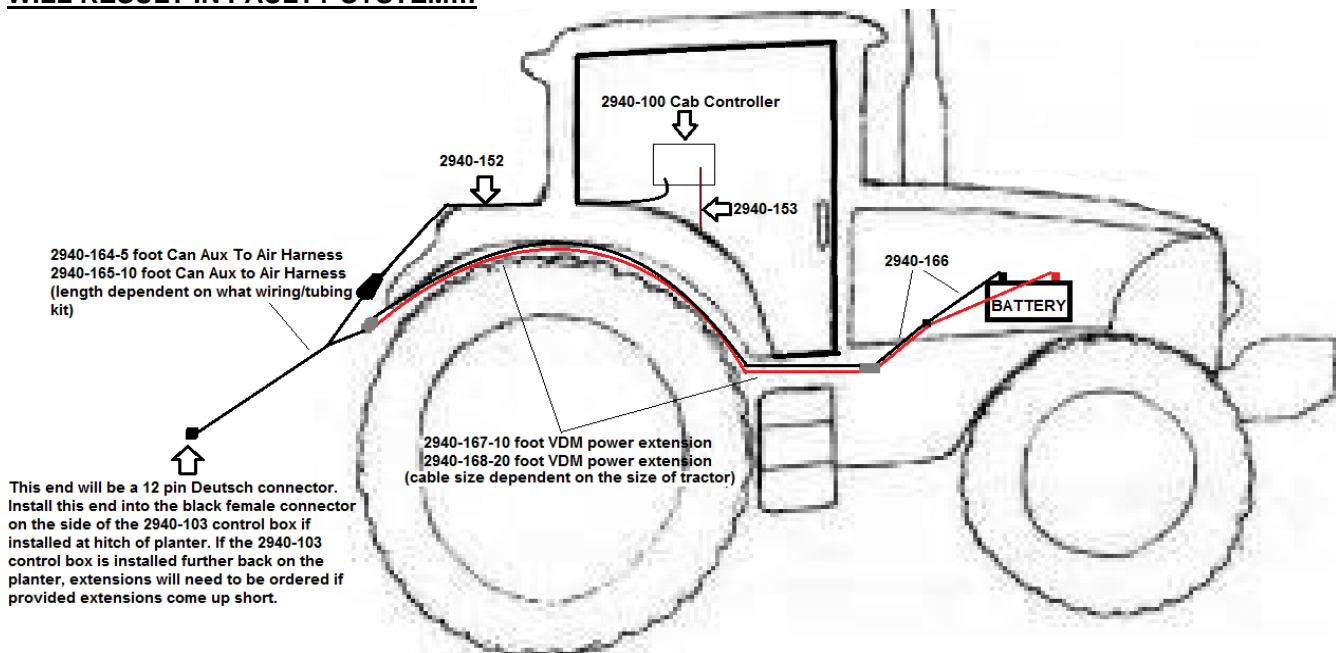

Power and Cab Controller Communication

Step 1: Install the 2940-166 VDM power cable with 40 amp breaker on the battery, red cable goes on the positive (+) stud and the black cable goes on the negative (-) stud.

Step 2: Install the 2940-167 (10ft) or 2940-168 (20ft)VDM power extension cable to the 2940-166 and route to the hitch of the tractor

Step 3: Install the 2940-164 (5ft) or 2940-165 (10ft) CAN Aux to Air Harness. This harness has 3 ends. Install the Anderson power connector to the VDM power extension, install the black CAN connector to the CAN connector attached to the cable that routes to the cab controller (from step 4 on page 23), and install the male black 12 pin Deutsch connector to the female end on the side of the 2940-103 Control Box. If the control box is mounted further back than the hitch of the planter, Can Aux to Air extension harnesses need to be installed. 2940-170 is a 10 foot CAN Aux to Air extension, 2940-171 is a 30 foot CAN Aux to Air extension, & a 2940-430 is a 20 foot CAN Aux to Air extension.

Hydraulic Communication Harness

(Only if application is using the Yetter Hydraulic Compressor)

Step 1: Install the 2940-181 hydraulic compressor solenoid/switch harness, male 2 pin connector connects to female on the hydraulic block on the side of the compressor housing, the female 2 pin connector connects to the male 2 pin connector on the pressure switch.

Step 2: Connect the 2940-182 (20ft) or 2940-189 control harness to the 4 pin connector of the 2940-181 and route to 2940-103 control box.

Step 3: Connect the 2940-182 or 2940-189 into the 4 pin female connector on the 2940-103 control box.

2940 -136 Dump Valve Kit Installation

Step 1-Align the holes on valve(8) with mounting plate(3) holes. Insert bolts(5) through the aligned holes and start the nuts(4) on the threads. Tighten nut with ¼" wrench while holding bolt with a phillips screwdriver until tight.

Step 2-Install supplied 6" piece of airline(6) in port 1, the vent elbow(7).

Step 3-If install is on a John Deere planter, use flat flanged nut(1) to install Dump Valve assembly by placing circle cut out on mounting tab(3) on U-bolt used to mount the row unit to planter toolbar. Pinch mounting tab(3) between existing nut on U-bolt and the provided flat flanged nut(1). If install is on any other model of planters, use the serrated flanged nut(2) for the install of the dump valves.

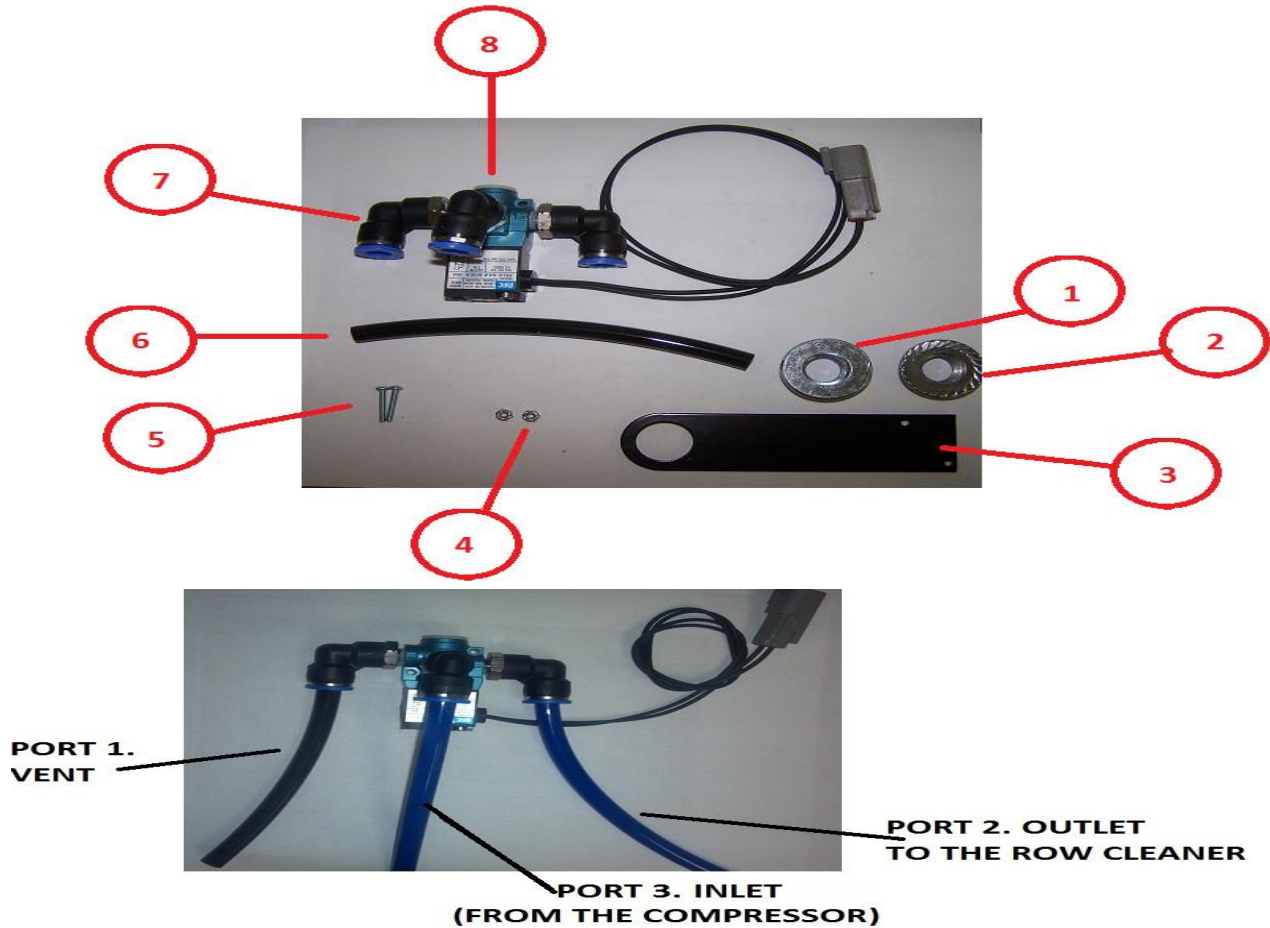

The picture below on the left is an example of how to mount a dump valve to a row unit. The picture below on the right is an example on how to mount 2 dump valves on 1 row unit.

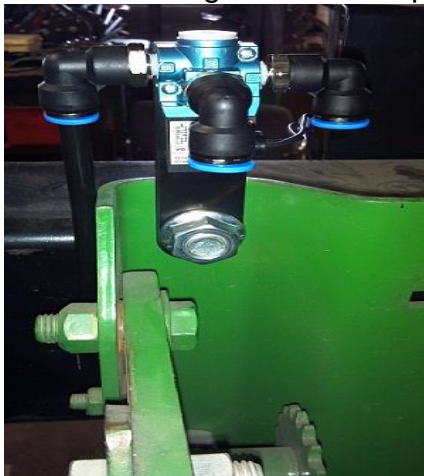

Airline Routing-Planter Frame

Below is a suggested method for safely and securely routing the airlines on the planter frame whether installing trunk airlines (airlines that route to the row cleaners) or the supply airlines (lines that route from the 2940-103 control box to the dump valves). Safely route the lines on the frame that the row units are mounted to. After airline & dump valve harnessing is complete, use provided zip ties to keep parts away from pinch & wear points.



Airline Routing-Row Unit

Below is a suggested method for safely and securely routing the airlines from the air bag to tee's on the planter frame. These are generalizations and **YOU SHOULD USE YOUR OWN BEST JUDGEMENT** in routing air lines.

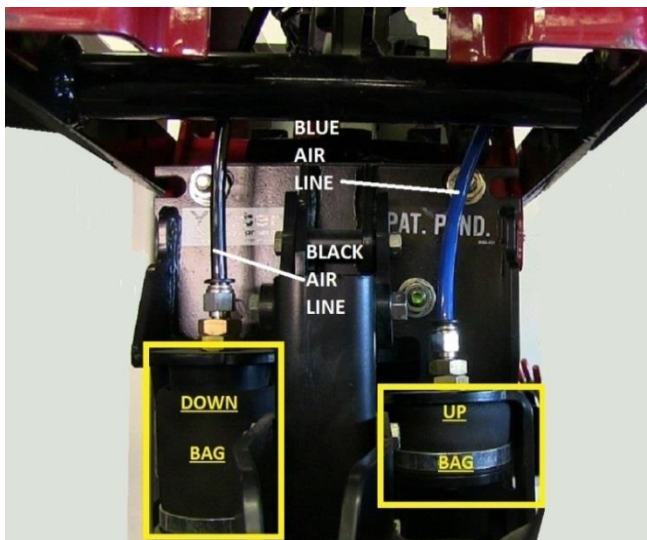

Specific airline routing will be dependent upon:
 * Row unit make (JD, Kinze, CNH, AGCO, etc)
 * Parallel arm length

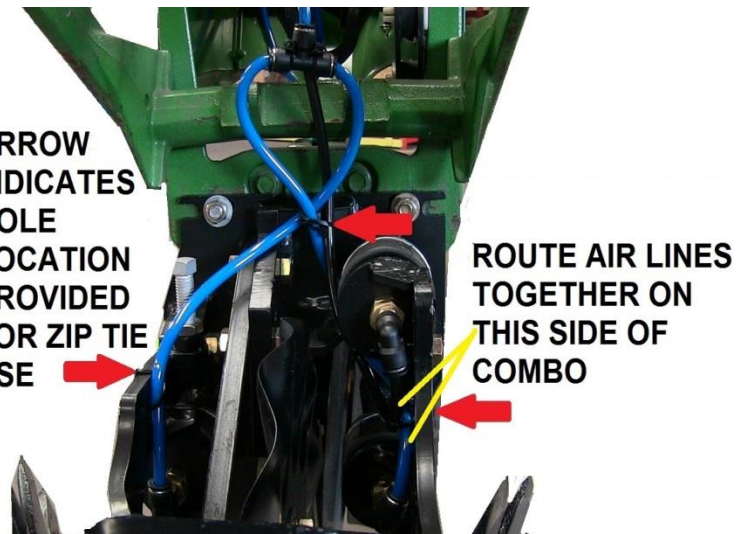

On the 2940-010 Coulter Combo, the 2 air bags on the bottom of the bracket are for up pressure & the single air bag on top is for down pressure.

DO NOT pass the lines between the rear of the parallel arm and the row unit. This can act as both a pinch point and wear point. Use provided zip ties to keep airlines away from pinch & wear points & sharp or rotating objects that may cut the airline.

Airline Routing

The following pages are diagrams of the Air lines for various planter makes and models

Direction of flow is: from Supply Tank to Lift (Blue) and Down (Black) airlines to air bags. All airlines will be 3/8". Route the lines as efficiently and conveniently as possible. Use the airline colors to differentiate the lift pressure (Blue Air Line) and down pressure (Black Air Line) on the planter for trouble shooting, leak detection, & dump valve circuit indication. **If there is no diagram for your situation, contact a Yetter service representative (800-447-5777) and a drawing will be made.**

6 Row Dump Valve Diagram

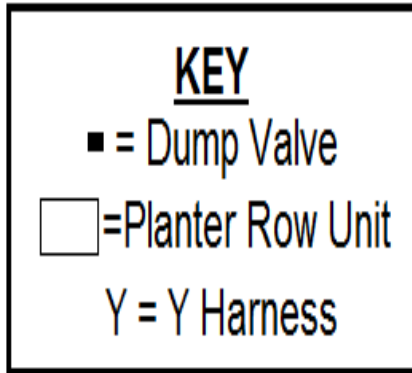

**Down
Pressure
Dump Valve**

Row

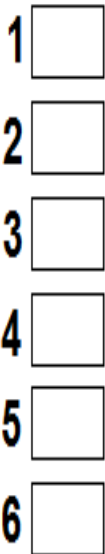

Routes to the 2
pin pigtail
labeled RM
DOWN DUMP

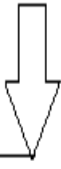

- Step 1:** Install 1 dump valve on row 3 & 1 dump valve on row 4.
- Step 2:** Install the male 12 pin Deutsch connector of the 2940-162 dump valve cable into the **GRAY** female connector on the side of the 2940-103 control box.
- Step 3:** Install the mating 2 pin connector of the 2940-156 black dump valve cable to the dump valve on row 3 & route the other end of the 2940-156 to the 2 pin connector labeled RM DOWN DUMP on the 2940-162 from step 2 & install.
- Step 4:** Install the mating 2 pin connector of the 2940-157 white dump valve cable to the dump valve on row 4 & route the other end of the 2940-157 to the 2 pin connector labeled RM UP DUMP on the 2940-162 from step 2 & install.

**Up
Pressure
Dump Valve**

Row

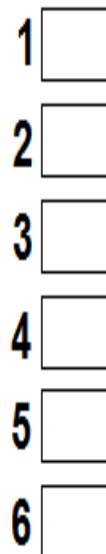

Routes to the 2 pin
pigtail labeled RM
UP DUMP

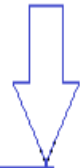

★ Aux 3 & Aux 4 on 2940-162 are not yet used ★

6 Row Airline Diagram

**Down Pressure
Black Airline
Row**

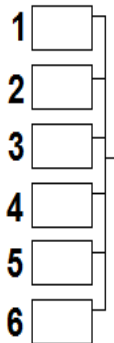

2940-103
Control
Box

Step 1: T1 & T2 Route blue & black line from row 1 to row 6. Install the black airline in the down pressure (larger) air bag & the blue airline in the up pressure (smaller) air bag. Trace both airlines back to row 1 installing tees in each (blue & black) airline at each row unit. From each tee in the up pressure (blue airline) circuit, route blue airline to the up pressure air bag and install in the fitting. From each tee in the down pressure (black airline) circuit, route black airline to the down pressure air bag and install in the fitting. When back to row 1, cut each airline to length & install each airline into the matching air bag.

Step 2: On row 3 at the down pressure dump valve, install a tee in the black airline installed in step 1. Install black airline from the open port on the tee to the outlet port on the dump valve.

Step 3: On row 4 at the up pressure dump valve, install a tee in the blue airline installed in step 1. Install blue airline from the open port on the tee to the outlet port of the dump valve.

Step 4: S1 Route black airline from the RD port in the 2940-103 control box to the inlet port on the down pressure dump valve on row 3.

Step 5: S2 Route blue airline from the RU port of the 2940-103 control box to the inlet port of the up pressure dump valve on row 4.

Step 6: Install a plug (2940-352) into the WT port on the 2940-103 control box to prevent air loss. Another way to do this is to cut a 6inch piece of black airline, install one end into the WT port, fold the airline over causing a kink, & zip tie the airline to stay like this. This circuit will not be used with this size of planter.

**Up Pressure
Blue Airline
Row**

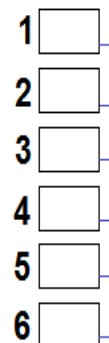

2940-103
Control
Box

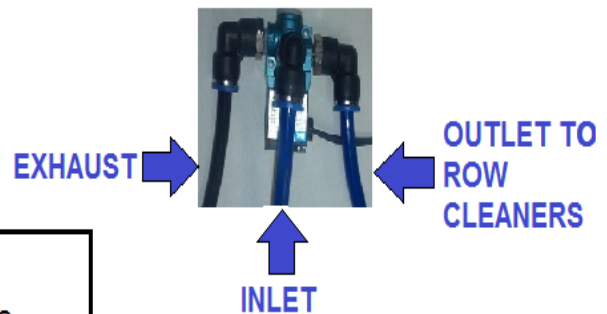
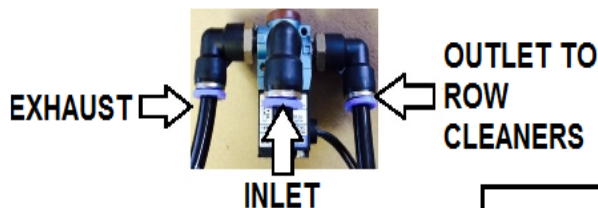

KEY

- = Dump Valve
- = Planter Row Unit
- T1-2 = Trunk Line
- S1-2 = Supply Line

6/11 or 6/12 Split Row Dump Valve Diagram

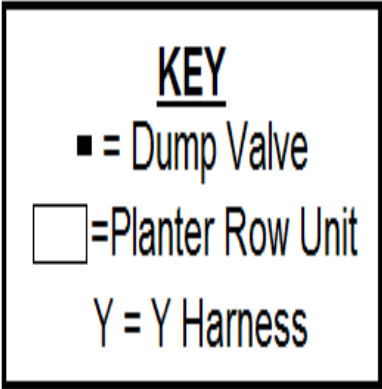

Down
Pressure
Dump Valve

Row

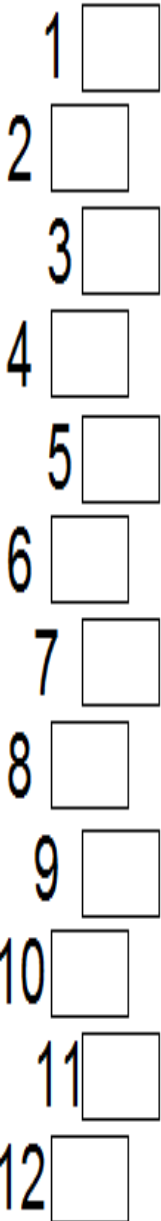

Routes to the 2
pin pigtail labeled
RM DOWN DUMP

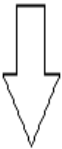

Step 1: Install 1 dump valve on row 6 and 1 dump valve on row 7.

Step 2: Install the male 12 pin Deutsch connector of the 2940-162 dump valve cable into the **GRAY** female connector on the side of the 2940-103 control box.

Step 3: Route & install the appropriate length of black dump valve cable(s) from the open 2 pin connector of the dump valve on row 6 to the 2 pin connector labeled RM DOWN DUMP on the 2940-162 harness installed in step 2.

Step 4: Route & install the appropriate length of white dump valve cable(s) from the open 2 pin connector on the dump valve on row 7 to the 2 pin connector labeled RM UP DUMP on the 2940-162 harness installed in step 2.

Up
Pressure
Dump Valve

Row

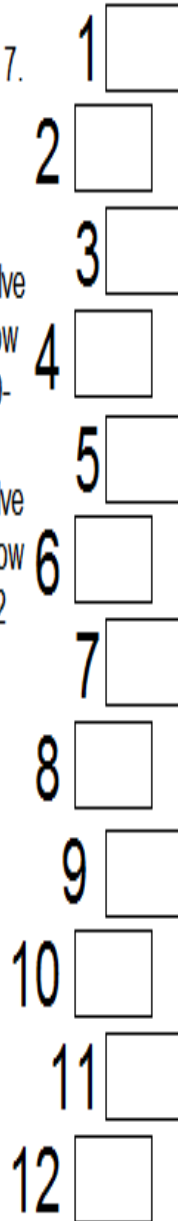

Routes to the 2
pin pigtail labeled
RM UP DUMP



★ Aux 3 & Aux 4 on 2940-162 are not yet used ★

6/11 or 6/12 Split Row Airline Diagram

Down Pressure
Black Airline
on corn rows

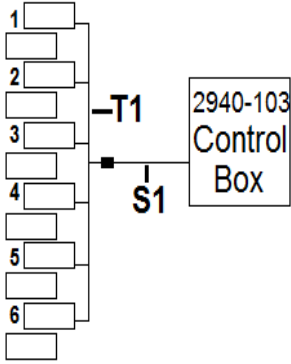

KEY

- = Dump Valve
- = Ball Valve
- = Planter Row Unit
- S1-2 = Supply Airline
- T1-4 = Trunk Airline

Step 1: T1 & T2 Route black & blue airline from the first corn row to the last corn row. Install the black airline in the fitting of the down pressure (larger) air bag & the blue airline in the fitting of the up pressure (smaller) air bag on the last corn row. Trace both airlines back to the first corn row installing tees in each airline at each corn row. Route & install blue airline from the up pressure air bag fitting to the tee in the up pressure (blue) circuit for that corn row. Route & install black airline from the down pressure air bag fitting to the tee in the down pressure (black) circuit for that corn row. When back to the first corn row, cut each airline to length & install each airline into the matching air bag.

Step 2: S1 At the dump valve on split row 3, cut & install a tee into the T1 airline installed in step 1. Route black airline from the remaining open port in the tee to the outlet port of the dump valve & install. Route & install black airline from the RD port on the 2940-103 control box to the inlet port of the dump valve on split row 3.

Step 3: S2 At the dump valve on corn row 4, cut & install a tee into the T2 airline installed in step 1. Route blue airline from the remaining open port in the tee to the outlet port of the dump valve & install. Route & install blue airline from the RU port on the 2940-103 control box to the inlet port of the dump valve on corn row 4.

Step 4: T3 & T4 Route black & blue airline from the first split row to the last split row. Install the black airline in the fitting of the down pressure (larger) air bag & the blue airline in the fitting of the up pressure (smaller) air bag on the last split row. Trace both airlines back to the first split row installing tees in each airline at each split row. Route & install blue airline from the up pressure air bag fitting to the tee in the up pressure (blue) circuit for that split row. Route & install black airline from the down pressure air bag fitting to the tee in the down pressure (black) circuit for that split row. When back to the first split row, cut each airline to length & install each airline into the matching air bag.

Step 5: At the dump valve on split row 3, cut & install a tee into the T3 airline installed in step 4. At the dump valve on corn row 4, cut & install a tee into the T4 airline installed in step 4.

Step 6: Install a tee just downstream of the outlet port on the dump valve on split row 3. Install a 6 inch piece of black airline in the remaining port of that tee. Install a ball valve (2940-342) on the open end of the black airline. Route & install black airline from the open port on the ball valve to the tee in the T3 airline installed in step 5.

Step 7: Install a tee just downstream of the outlet port on the dump valve on corn row 4. Install a 6 inch piece of blue airline in the remaining port of that tee. Install a ball valve on the open end of the blue airline. Route & install blue airline from the open port on the ball valve to the tee in the T4 airline installed in step 5.

Step 8: Install a plug in the WT port on the 2940-103 control box. If plug not provided, install a 6 inch piece of any color of airline in the WT port, fold the airline in half causing a kink, & zip tie to keep airline in this position.

Up Pressure
Blue Airline
on corn rows

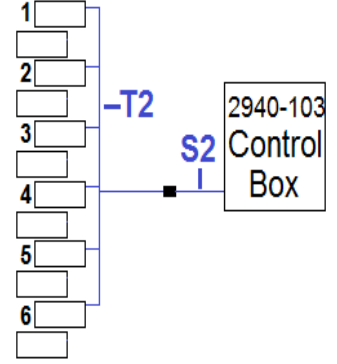

Up Pressure
Blue Airline
on split rows

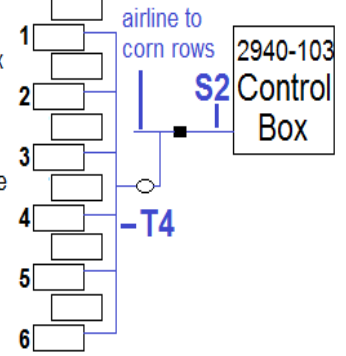

Down Pressure
Black Airline
on split rows

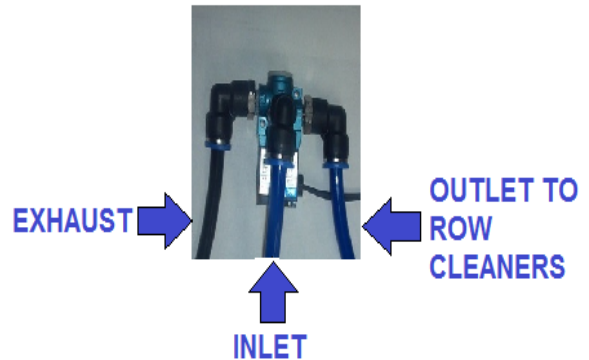
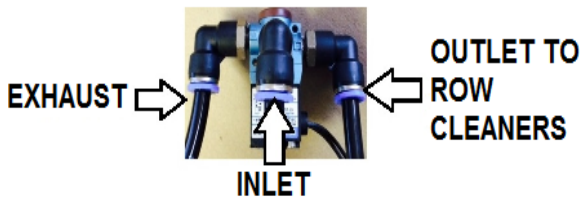
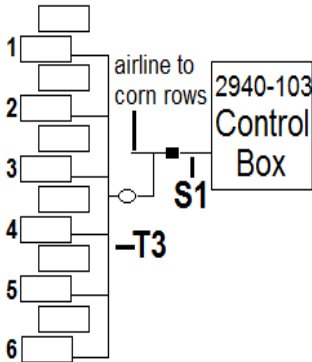

8 Row Dump Valve Diagram

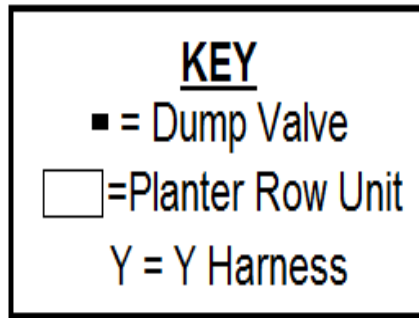

**Down
Pressure
Dump Valve**

Row

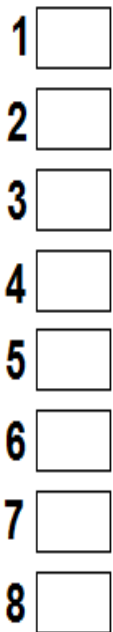

Routes to the 2
pin pigtail
labeled RM
DOWN DUMP



Step 1: Install 1 dump valve on row 4 & 1 dump valve on row 5.

Step 2: Install the male 12 pin Deutsch connector of the 2940-162 dump valve cable into the **GRAY** female connector on the 2940-103 control box.

Step 3: Install the mating 2 pin connector of the 2940-156 black dump valve cable to the dump valve on row 5. Route the other end of the 2940-156 to the 2 pin connector labeled RM DOWN DUMP on the 2940-162 from step 2 & install.

Step 4: Install the mating 2 pin connector of the 2940-157 white dump valve cable to the dump valve on row 4. Route the other end of the 2940-157 to the 2 pin connector labeled RM UP DUMP on the 2940-162 from step 2 & install.

**Up
Pressure
Dump Valve**

Row

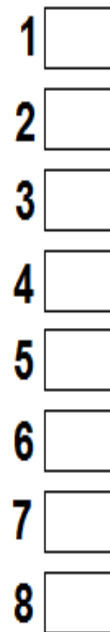

Routes to the 2 pin
pigtail labeled RM
UP DUMP

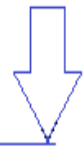

★ Aux 3 & Aux 4 on 2940-162 are not yet used ★

8 Row Airline Diagram

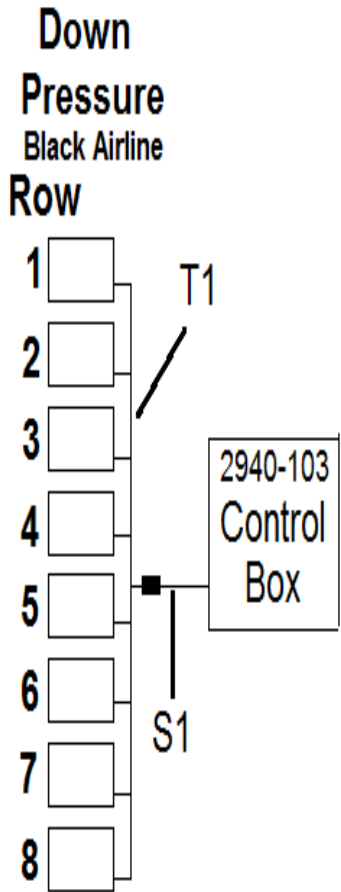

Step 1: T1 & T2 Route blue & black airline from row 1 to row 8. Install the black airline in the down pressure (larger) air bag & blue airline in the up pressure (smaller) air bag. Trace both airlines back to row 1 installing tees in each (blue and black) airline at each row unit. From each tee in the up pressure (blue airline) circuit, route blue airline to the up pressure air bag and install in the fitting. From each tee in the down pressure (black airline) circuit, route black airline to the down pressure bag and install in the fitting. When back to row 1, cut each airline to length and install each airline to the matching air bag.

Step 2: On row 5 at the down pressure dump valve, install a tee in the black airline installed in step 1. Install black airline from the open port on the tee to the outlet port on the dump valve.

Step 3: On row 4 at the up pressure dump valve, install a tee in the blue airline installed in step 1. Install blue airline from the open port on the tee to the outlet port on the dump valve.

Step 4: S1 Route black airline from the RD port in the 2940-103 control box to the inlet port on the down pressure dump valve on row 5 & install.

Step 5: S2 Route blue airline from the RU port on the 2940-103 control box to the inlet port on the up pressure dump valve or row 4 & install.

Step 6: Install a plug (2940-352) into the WT port on the 2940-103 control box to prevent air loss. Another way to do this is to cut a 6inch piece of black airline, install one end into the WT port, fold the airline over causing a kink, & zip tie the airline to stay like this. This circuit will not be used with this size of planter.

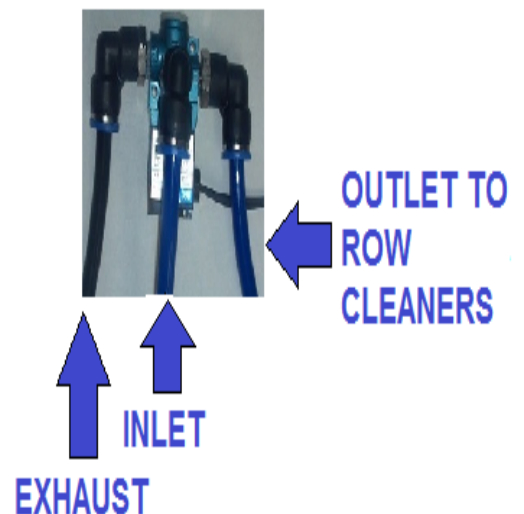
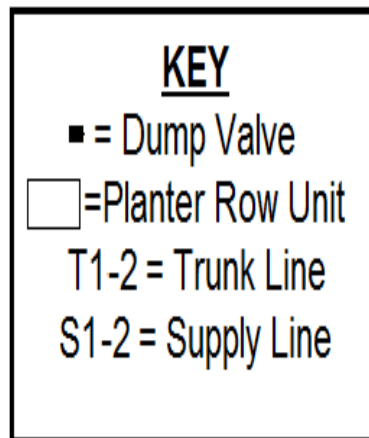
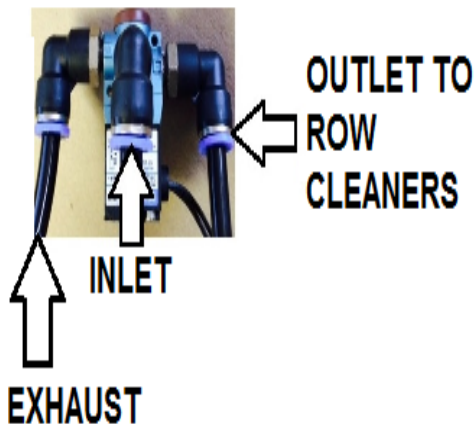
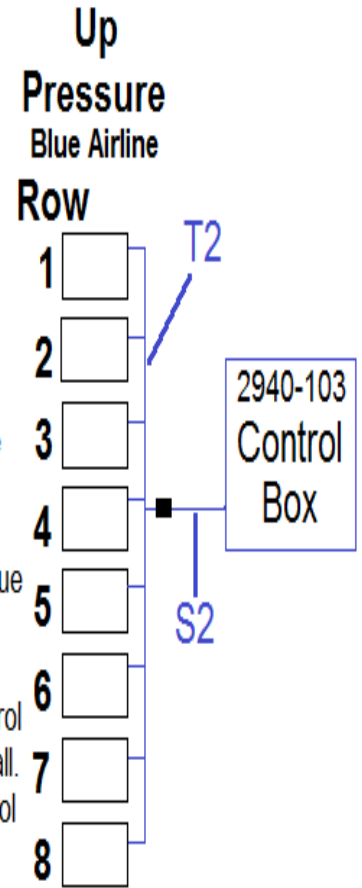

8/15 & 8/16 Split Row Dump Valve Diagram

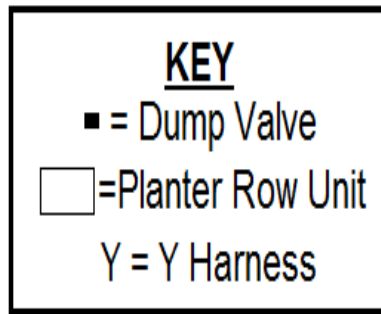

**Down
Pressure
Dump Valve**

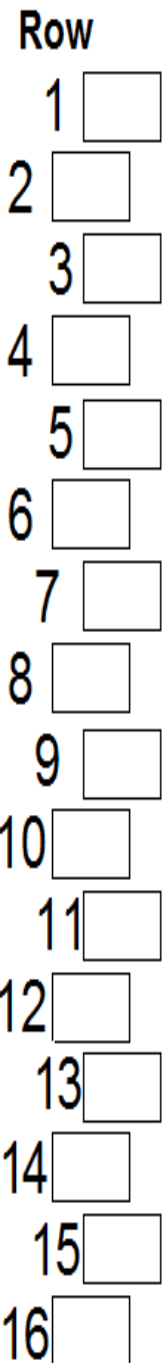

Step 1: Install 1 dump valve on each of the following rows: 5, 9, & 11.

Step 2: Install the male 12 pin Deutsch connector of the 2940-162 dump valve cable into the **GRAY** female connector on the side of the 2940-103 control box.

Step 3: Install a 2940-156 15ft black dump valve cable on the 2 pin connector of the dump valve on row 5 and route to row 9 but don't install. Connect the black dump valve cable ran from the dump valve on row 5 and the 2 pin connector of the dump valve on row 11 using a 2940-158 black Y harness.

Step 4: Route & install the appropriate length of black dump valve cable(s) from the open 2 pin connector of the black Y harness at the dump valve on row 11 to the 2 pin connector labeled RM DOWN DUMP on the 2940-162 dump valve harness installed in step 2.

Step 5: Route & install the appropriate length of white dump valve cable(s) from the open 2 pin connector on the dump valve on row 9 to the 2 pin connector labeled RM UP DUMP on the 2940-162 dump valve harness installed in step 2.

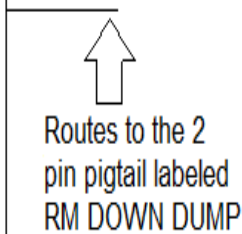

**Up
Pressure
Dump Valve**

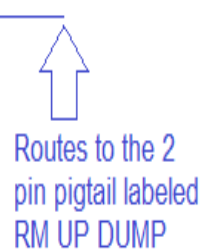
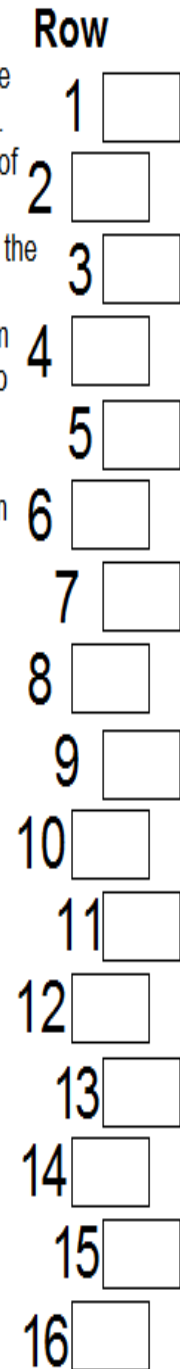

★ Aux 3 & Aux 4 on 2940-162 are not yet used ★

8/15 & 8/16 Split Row Airline Diagram

KEY

■ = Dump Valve

□ = Planter Row Unit

○ = Ball Valve

T1-4 = Trunk Line

S1-2 = Supply Line

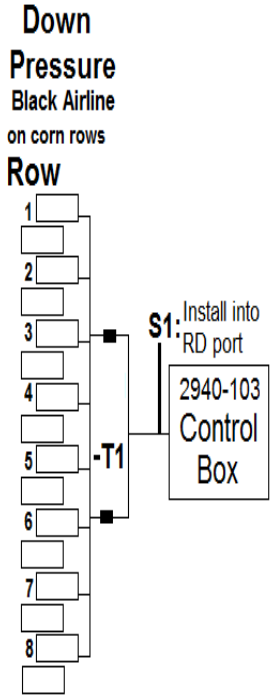

Step 1: T1 & T2 Route black & blue airline from the first corn row to the last corn row. Install the black airline in the fitting of the down pressure (larger) air bag & the blue airline in the fitting of the up pressure (smaller) air bag on the last corn row. Trace both airlines back to the first corn row installing tees in each airline at each corn row. Route & install blue airline from the up pressure air bag fitting to the tee in the up pressure (blue) circuit for that corn row. Route & install black airline from the down pressure air bag fitting to the tee in the down pressure (black) circuit for that corn row. When back to the first corn row, cut each airline to length & install each airline into the matching air bag.

Step 2: S1 At the dump valves on corn row 3 & corn row 6, cut & install a tee into the T1 airline installed in step 1. Route & install black airline from the remaining open port in each tee to the outlet port of the dump valve for that tee. Route & install black airline from the RD port on the 2940-103 control box to the center of the planter & install a tee. From each side of the tee, route black airline to the inlet port of the dump valves on corn row 3 & corn row 6.

Step 3: S2 At the dump valve on corn row 5, cut & install a tee into the T2 airline installed in step 1. Route blue airline from the remaining open port in the tee to the outlet port of the dump valve & install. Route & install blue airline from the RU port on the 2940-103 control box to the inlet port of the dump valve on corn row 5.

Step 4: T3 & T4 Route black & blue airline from the first split row to the last split row. Install the black airline in the fitting of the down pressure (larger) air bag & the blue airline in the fitting of the up pressure (smaller) air bag on the last split row. Trace both airlines back to the first split row installing tees in each airline at each split row. Route & install blue airline from the up pressure air bag fitting to the tee in the up pressure (blue) circuit for that split row. Route & install black airline from the down pressure air bag fitting to the tee in the down pressure (black) circuit for that split row. When back to the first split row, cut each airline to length & install each airline into the matching air bag.

Step 5: At the dump valves on corn row 3 & corn row 6, cut & install a tee into the T3 airline installed in step 4. At the dump valve on corn row 5, cut & install a tee into the T4 airline installed in step 4.

Step 6: Install a tee just downstream of the outlet port on the dump valves on corn row 3 & corn row 6. Install a 6 inch piece of black airline in the remaining port of that tee. Install a ball valve (2940-342) on the open end of each 6 inch piece black airline. Route & install black airline from the open port on each ball valve to each tee in the T3 airline installed in step 5.

Step 7: Install a tee just downstream of the outlet port on the dump valve on corn row 5. Install a 6 inch piece of blue airline in the remaining port of that tee. Install a ball valve on the open end of the blue airline. Route & install blue airline from the open port on the ball valve to the tee in the T4 airline installed in step 5.

Step 8: Install a plug in the WT port on the 2940-103 control box. If plug not provided, install a 6 inch piece of any color of airline in the WT port, fold the airline in half causing a kink, & zip tie to keep airline in this position. The WT port is not used with this size of planter.

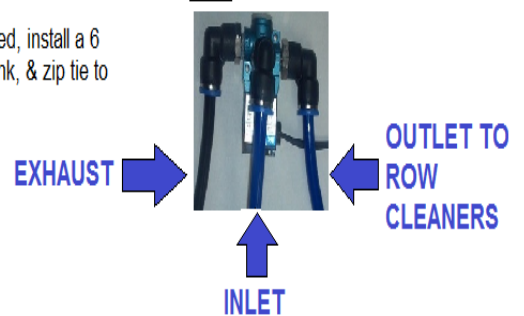
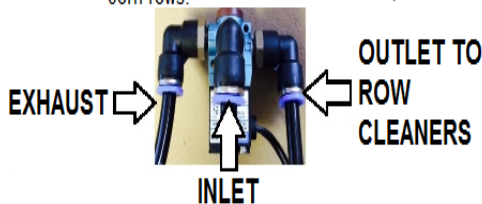
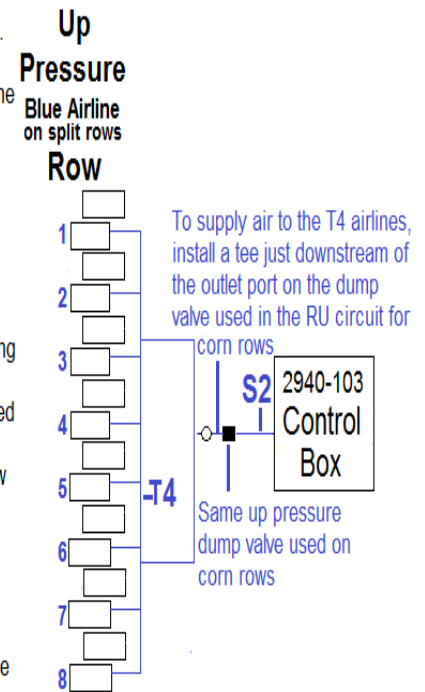
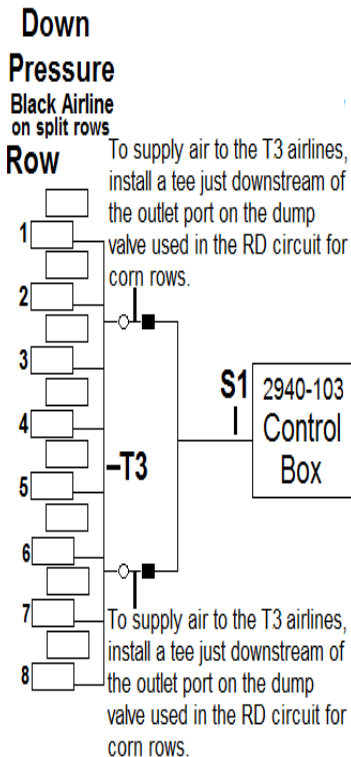
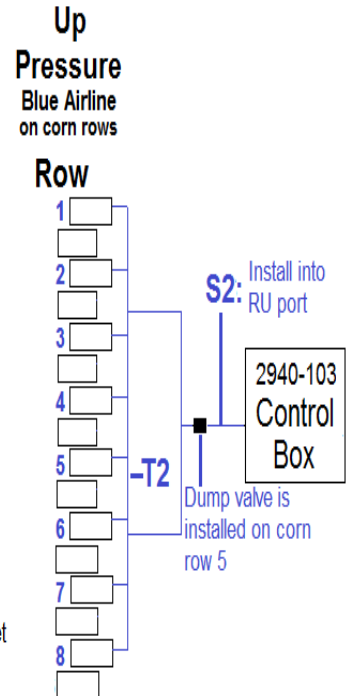

12 Row Dump Valve Diagram

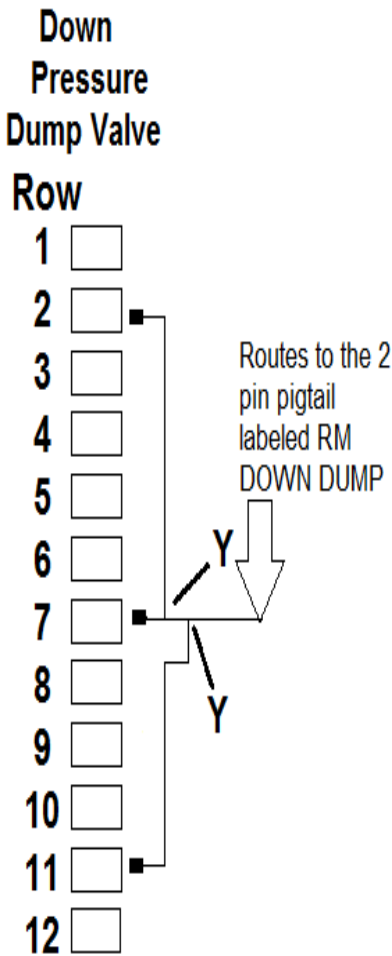
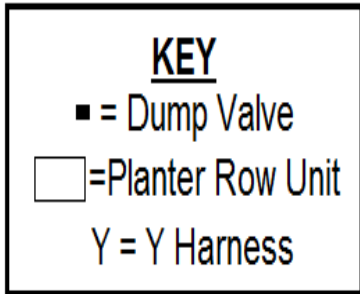

- Step 1:** Install 2 dump valves on each of the following rows: 2 & 11. Install 1 dump valve on each of the following rows: 6 & 7.
- Step 2:** Install the male 12 pin Deutsch connector of the 2940-162 dump valve cable into the **GRAY** female connector on the side of the 2940-103 control box.
- Step 3:** At row 2, install the mating 2 pin connector on the 2940-156 15ft black dump valve cable to the 2 pin cable on one dump valve and install the mating 2 pin connector on the 2940-157 15ft white dump valve cable to the 2 pin cable on the other dump valve. Route the 2940-156 black dump valve cable to row 7 and route the 2940-157 white dump valve cable to the dump valve on row 6.
- Step 4:** At row 11, install the mating 2 pin connector on the 2940-156 15ft black dump valve cable to the 2 pin cable on one dump valve and install the mating 2 pin connector on the 2940-157 15ft white dump valve cable to the 2 pin cable on the other dump valve. Route the 2940-156 black dump valve cable to row 7 and route the 2940-157 white dump valve cable to the dump valve on row 6.
- Step 5:** At row 7, install a 2940-158 black Y harness connecting the black dump valve cables routed in steps 3 & 4.
- Step 6:** Install a second black Y harness connecting the dump valve on row 7 to the Y harness installed in step 5.
- Step 7:** Route the appropriate length of black dump valve cable(s) from the open 2 pin connector at row 7 (from step 6) to the 2 pin connector labeled RM DOWN DUMP on the 2940-162 from step 2.
- Step 8:** At row 6, install a 2940-159 white Y harness connecting the white dump valve cables routed in steps 3 & 4.
- Step 9:** Install a second white Y harness connecting the dump valve on row 6 to the Y harness installed in step 8.
- Step 10:** Route appropriate length of white dump valve cable(s) from the open 2 pin connector at row 6 (from step 9) to the 2 pin connector labeled RM UP DUMP on the 2940-162 from step 2.

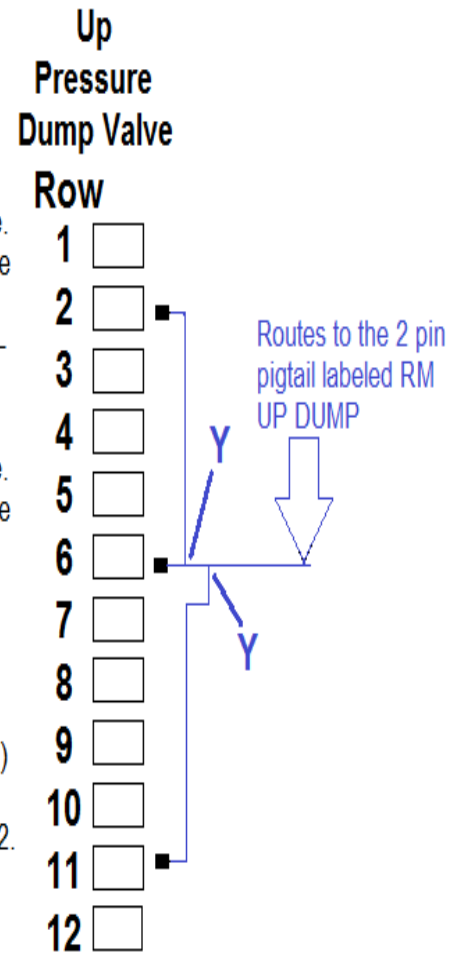

★ Aux 3 & Aux 4 on 2940-162 are not yet used ★

12 Row Airline Diagram

Step 1:T1 & T2 Route blue & black airline from row 1 to row 3. Install the black airline in the down pressure (larger) air bag fitting & blue line in the up pressure (smaller) air bag fitting. Install a tee in each color of airline at row 2. Install blue airline from the up pressure air bag to the tee in the blue airline & black airline from the down pressure air bag to the tee in the black airline. At row 1, cut both airlines to length & install each airline into the matching air bag.

Step 2: Cut and tee T1 & T2 airline next to the matching dump valve on row 2. Route black airline from the tee in the T1 airline into the outlet port of the down pressure dump valve (black cable) and route blue airline from tee in the T2 airline to the outlet port of the up pressure dump valve (white cable).

Step 3:T5 & T6 Route blue and black airline from row 12 to row 10. At row 10, install each airline into the matching air bag's fitting. Install a tee in each airline at row 11. Install blue airline from the up pressure air bag fitting to the tee in the blue airline & black airline from the down pressure air bag fitting to the tee in the black airline. At row 12, cut both airlines to length and install airline into the matching air bag.

Step 4: Cut and tee T5 & T6 airline next to the matching dump valve on row 11. Route black airline from the tee in the T5 airline into the outlet port of the down pressure dump valve (black cable) and route blue airline from tee in the T6 airline to the outlet port of the up pressure dump valve (white cable).

Step 5:T3 & T4 Route blue and black airline from row 4 to row 9. Install each airline at row 9 into the matching air bag. Trace both airlines back to row 4 installing a tee in each airline at each row. Install blue airline from the up pressure air bag fitting to the tee in the up pressure circuit. Install black airline from the down pressure air bag fitting to the tee in the down pressure circuit. At row 4, cut both airlines to length and install into the matching air bag.

Step 6: Cut and tee T3 airline next to the dump valve on row 7. Install a tee in the T4 airline next to the dump valve on row 6. Route & install black airline from the tee in T3 airline into the outlet port of down pressure dump valve on row 7 and route blue airline from the tee in T4 to the outlet port of the up pressure dump valve on row 6.

Step 7:S1 Route black airline from RD port of the 2940-103 control box to the nearest point on the main frame and install a tee. From each side of the tee, route black airline to the inlet port on the down pressure dump valve on each wing/side of the planter. (Rows 2 and 11) (follow the same routing path as the trunk lines)

Step 8:S2 Route blue airline from the RU port of the 2940-103 control box to the nearest point on the main frame and install a tee. Install a 6 inch piece of blue line into one port of tee. Install a second tee on the open end 6 inch piece of blue airline. This will give you 3 open ports on this circuit to use. Route blue airline from 2 of those ports to each inlet port on the up pressure dump valve on the wings/sides of the planter on row 2 and row 11 & install. Route blue airline from remaining port of the tee to the inlet port on the up pressure dump valve on row 6 & install.

Step 9:S3 Route black airline from the WT port of the 2940-103 control box to the inlet port of the down pressure dump valve on row 7.

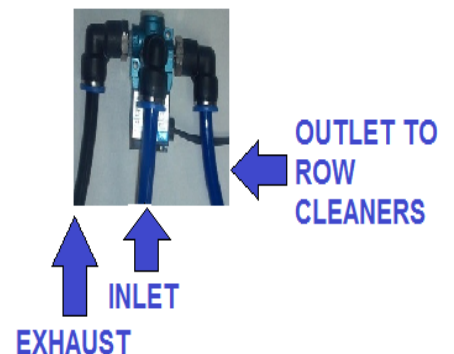
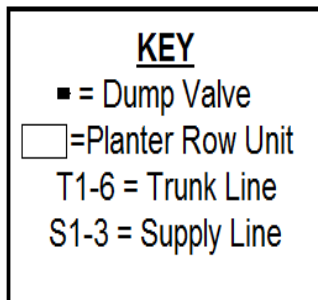
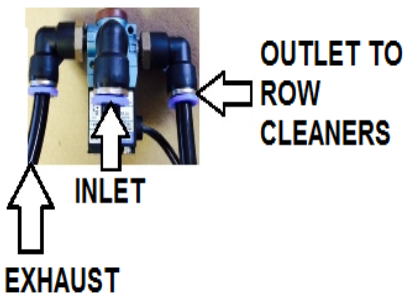
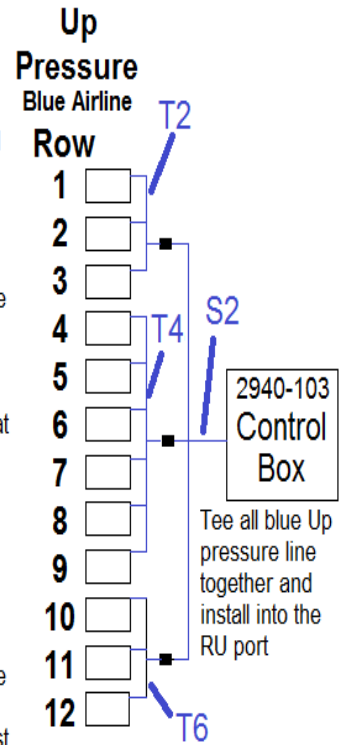
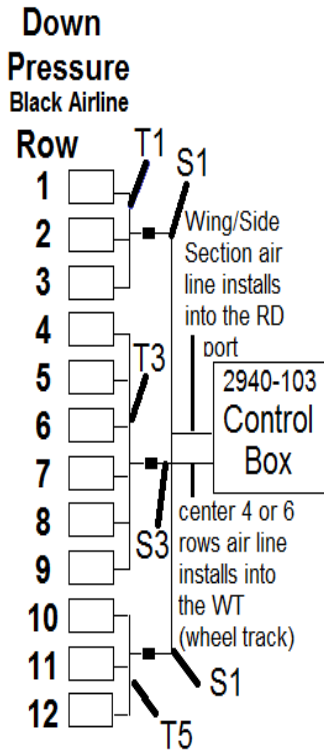

12/23 & 12/24 Split Row Dump Valve Diagram

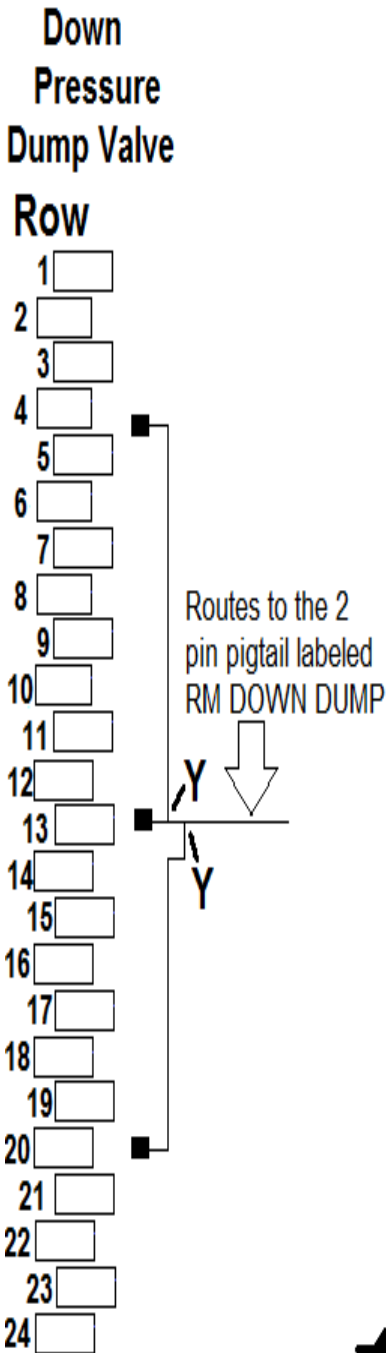
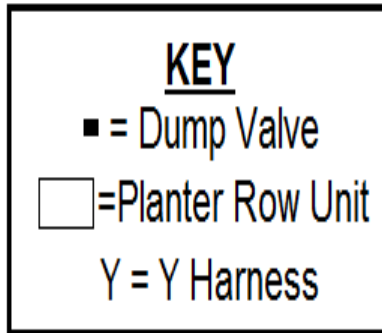

Step 1: Install 1 dump valve on each of the following rows: 4, 5, 12, 13, 19, & 20

Step 2: Install the male 12 pin Deutsch connector of the 2940-162 dump valve cable into the **GRAY** female connector on the side of the 2940-103 control box.

Step 3: At row 4 & 20, install a 2940-156 15ft black dump valve cable from the 2 pin connector on each dump valve and route to the dump valve on row 13 but don't install.

Step 4: At row 13, install a 2940-158 black Y harness to connect the 15ft black dump valve cables from row 4 & 20 (from step 3). Install a second black Y harness to connect the dump valve on row 13 to the Y harness connecting rows 4 & 20, so that only 1 open 2 pin connector remains.

Step 5: Route the appropriate length of black dump valve cable(s) from the open 2 pin connector on the Y harness from step 4 to the 2 pin connector labeled RM DOWN DUMP on the 2940-162 dump valve harness installed in step 2.

Step 6: At row 5 & 19, route 2940-157 15ft white dump valve cables from the 2 pin connector on each dump valve and route to the dump valve on row 12 but don't install

Step 7: Install a 2940-159 white Y harness connecting the cables routed in step 6. Install a second white Y harness to connect the dump valve on row 12 to the Y harness connecting rows 5 & 19.

Step 8: Route the appropriate length of white dump valve cable(s) from the open 2 pin connector on the Y harness installed in step 7 to the 2 pin connector labeled RM UP DUMP on the 2940-162 dump valve harness installed in step 2.

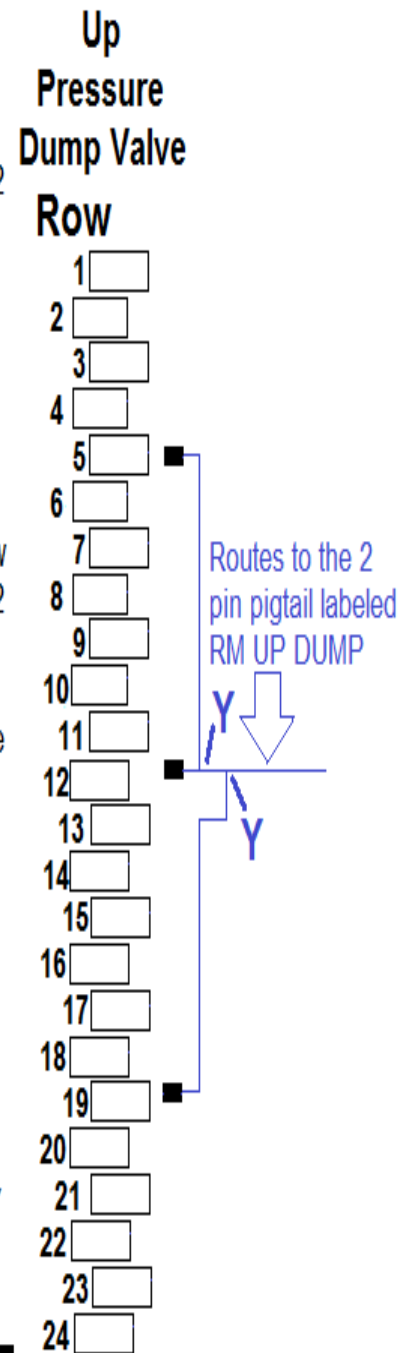

★ Aux 3 & Aux 4 on 2940-162 are not yet used ★

12/23 & 12/24 Split Row Airline Diagram

Down Pressure
Black Airline
on corn rows

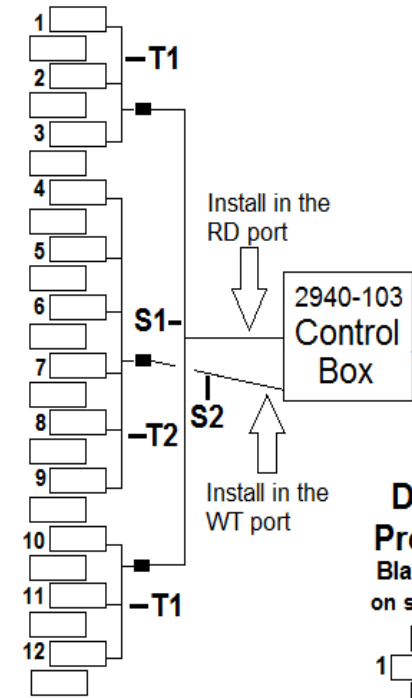

KEY

- = Dump Valve
- = Planter Row Unit
- = Ball Valve
- T1-6 = Trunk Line
- S1-3 = Supply Line

Up Pressure
Blue Airline
on corn rows

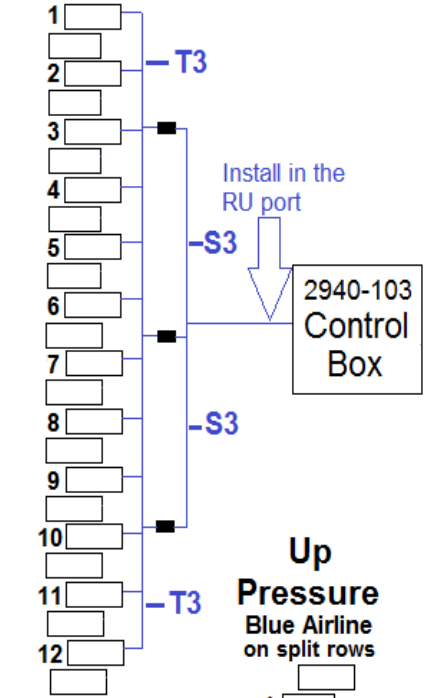

Down Pressure
Black Airline
on split rows

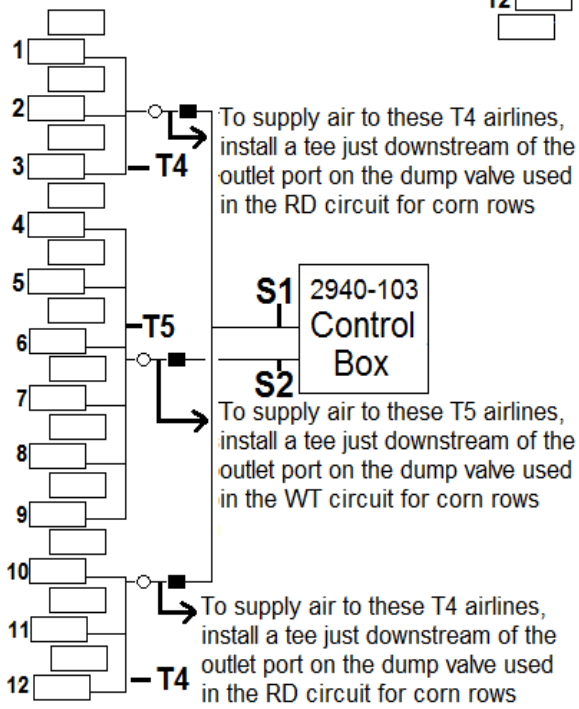

Up Pressure
Blue Airline
on split rows

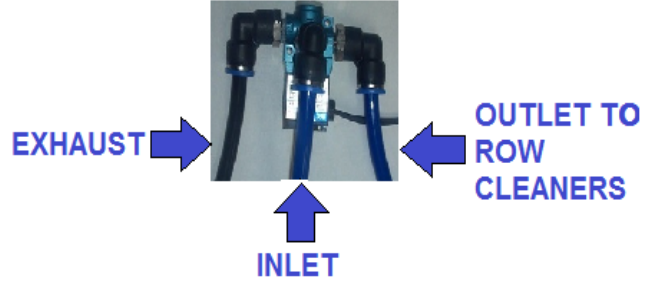
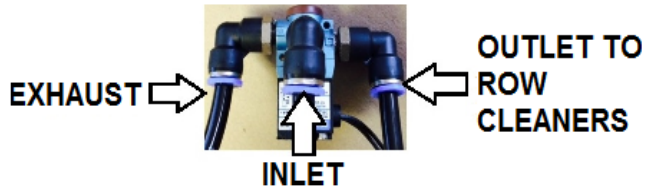
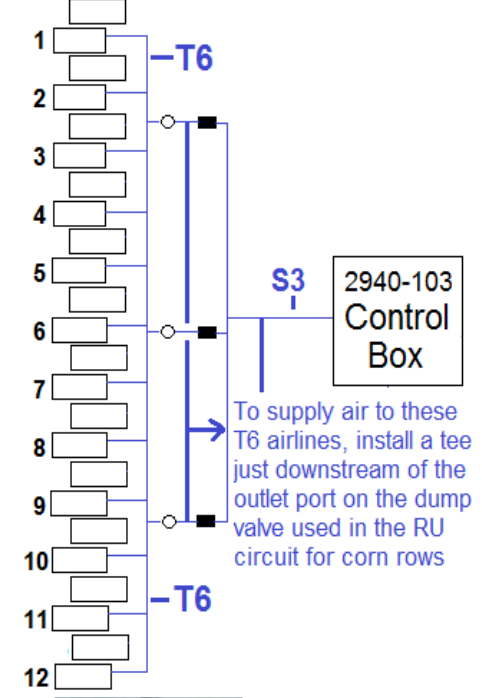

12/23 & 12/24 Split Row Airline Diagram Con't

- Step 1: T1** Route black airline from corn row 1 to corn row 3 & install the airline into the down pressure air bag (larger) fitting. Trace this same airline back to corn 1, installing a tee at corn row 2, & then cutting the black airline to length and installing in the down pressure air bag fitting on corn row 1. Install an additional black airline in the down pressure air bag fitting on corn row 2 & cut to length to install in the tee.
- Step 2: T1** Route black airline from corn row 12 to corn row 10 & install into the down pressure air bag (larger) fitting. Trace this same airline back to corn row 12, installing a tee at corn row 11, & then cutting the black airline to length & installing in the down pressure air bag fitting on corn row 12. Install an additional black airline in the down pressure air bag fitting on corn row 11 & cut to length to install in the tee.
- Step 3: S1** Install a tee in the black airline routing from corn row 1 to corn row 3. Install black airline in the remaining port on the tee & route to the outlet port on the dump valve on row 4 (split row 2) & install. Install a tee in the black airline that routes from corn row 10 to corn row 12. Install black airline in the remaining port on the tee, route to the outlet port on the dump valve on row 20 (split row 10), & install.
- Step 4: S1** Install black airline in the inlet port of the dump valves (used in step 3) on rows 4 & 20. Route the black airline from the inlet port of these dump valves to the center of the planter & install a tee to connect the airlines together. Install black airline in the open port of the tee, route to the RD port of the 2940-103 control box, & install.
- Step 5: T2** Route black airline from corn row 4 to corn row 9 & install the black airline into the fitting of the down pressure air bag on corn row 9. Trace this airline back to corn row 4, installing a tee at each corn row. When returned to corn row 4, cut to length & install into the fitting of the down pressure air bag. Install black airline from the down pressure air bag fittings on corn rows 5-8, route to the tee installed for that row, & install.
- Step 6: S2** Install a tee in the black airline installed in the first part of step 5 (T2) near the dump valve on row 13 (corn row 7). Measure & cut black airline to length between the tee & the dump valve on row 13. Install the black airline into the tee & into the outlet port on the dump valve on row 13.
- Step 7: S2** Install black airline from the inlet port of the dump valve used on row 13 (from step 6) to the WT port on the 2940-103 control box.
- Step 8: T3** Route blue airline from corn row 1 to corn row 12 & install into the up pressure air bag (smaller) fitting on corn row 12. Trace this airline back to corn row 1, installing tees at each corn row. When returned to corn row 1, cut the blue airline to length & install into the up pressure air bag fitting. Install blue airline into the up pressure air bag fitting on each corn row, cut to length, & install into the tee for that corn row.
- Step 9: S3** Install a tee into the T3 line (from step 8) next to the dump valves on rows 5, 12, & 19. Measure & cut blue airline to length between the tee & the dump valves. Install the blue airline from the tee to the outlet port of each up pressure dump valve.
- Step 10: S3** Install blue airline from the inlet port on the dump valves on rows 5 & 19 & route to the dump valve on row 12. Install a tee connecting the blue airline routed from the dump valves on rows 5 & 19. Measure, cut, & install blue airline from the remaining open port of the tee to the inlet port of the dump valve on row 12. Install an additional tee in the blue airline between the dump valve on row 19 and tee that connects row 19 & row 5's dump valves. Route blue airline from the remaining port of the tee to the RU port of the 2940-103 control box & install.
- Step 11: T4** Route black airline from split row 1 to split row 3 & install into the down pressure air bag (larger) fitting. Trace this same airline back to split row 1, installing a tee at split row 2, cutting the black airline to length & installing in the down pressure air bag fitting on split row 1. Install black airline in the down pressure air bag fitting on split row 2 & cut to length to install in the tee.
- Step 12: T4** Route black airline from split row 11/12 to split row 10 & install into the down pressure air bag (larger) fitting. Trace this same airline back to split row 11/12, installing a tee at corn row 11(if equipped with 12 split rows), & then cutting the black airline to length & installing in the down pressure air bag fitting on split row 12. Install black airline in the down pressure air bag fitting on split row 11 & cut to length to install in the tee for that row. If equipped with only 11 split rows, route black airline from split row 11 to split row 10 & install in the up pressure air bag fittings. Cut the black airline to length & install in the down pressure air bag fitting on row 11.
- Step 13: S4.** Install a tee downstream of the outlet port on dump valve on split row 2. Install a 6 inch piece of black airline in the tee & a ball valve (2940-342) on the open end of the 6 inch piece of airline. Install a tee in the T4 airline next to the dump valve on split row 2. Cut black airline to length from the tee to the open end of the ball valve & install. Install a tee downstream of the outlet port on the dump valve on corn row 10. Install a 6 inch piece of black airline in the tee & a ball valve on the open end of the 6 inch piece of airline. Install a tee in the T4 airline installed in step 12 next to the dump valve on corn row 10. Cut black airline to length from the tee to the open end of the ball valve & install.
- Step 14: T5** Route black airline from split row 4 to split row 9 & install into the down pressure air bag fitting on split row 9. Trace this same airline back to split row 4 installing a tee at each split row. At split row 4, cut the black airline to length & install into the down pressure air bag fitting. Install black airline from the down pressure air bag fitting on split rows 5-8, cut to length, & install into the tee installed for that row.
- Step 15: S5** Install a tee downstream of the outlet port on dump valve on split row 6. Install a 6 inch piece of black airline in the tee & a ball valve on the open end of the 6 inch piece of airline. Install a tee in the T5 airline from step 14 next to the dump valve on corn row 7. Install black airline from the tee to the open port of the ball valve.
- Step 16: T6** Route blue airline from split row 1 to split row 11/12 & install into the up pressure air bag fitting. Trace this airline back to split row 1 installing a tee at each split row, cutting blue airline to length at spit row 1, & installing the airline into the up pressure air bag fitting. Install blue airline from the up pressure air bag fitting to the tee installed for that split row.
- Step 17: S6** Install a tee downstream of the outlet port on the dump valves rows 5, 12, & 19. Install a 6 inch piece of blue airline in the tee & a ball valve on the open end of the 6 inch piece of blue airline. Install a tee in the T6 airline from step 16 next to the dump valves on rows 5, 12, & 19. Install blue airline from the tee to the open port of each ball valve.

16 Row Dump Valve Diagram

- Step 1:** Install 1 dump valve on each of the following rows: 3, 4, 8, 9, 13, & 14.
- Step 2:** Install the male 12 pin Deutsch connector of the 2940-162 dump valve cable into the **GRAY** female connector on the side of the 2940-103 control box.
- Step 3:** Install the mating 2 pin connector of the 2940-156 15ft black dump valve cable to the 2 pin cable on the dump valve on row 3 and route to the dump valve on row 9 but don't install.
- Step 4:** Install the mating 2 pin connector of the 2940-156 15ft black dump valve cable to the 2 pin cable on the dump valve on row 14 and route to the dump valve on row 9 but don't install.
- Step 5:** At row 9, install a 2940-158 black Y harness connecting the dump valve cables routed from the dump valves on row 3 & row 14 in steps 3 & 4.
- Step 6:** Install a second black Y harness connecting the dump valve on row 9 to the Y harness installed in step 5.
- Step 7:** Route the appropriate length of black dump valve cable (s) from the open 2 pin connector at row 9 (from step 6) to the 2 pin connector labeled RM DOWN DUMP on the 2940-162 installed in step 2.
- Step 8:** Install the mating 2 pin connector of the 2940-157 15ft white dump valve cable to the 2 pin cable on the dump valve on row 4 and route to the dump valve on row 8 but don't install.
- Step 9:** Install the mating 2 pin connector of the 2940-157 15ft white dump valve cable to the 2 pin cable on the dump valve on row 13 and route to the dump valve on row 8 but don't install.
- Step 10:** At row 8, install a 2940-159 white Y harness connecting the dump valve cables routed from the dump valves on row 4 & row 13 in steps 8 & 9.
- Step 11:** Install a second white Y harness connecting the dump valve on row 8 to the Y harness installed in step 10.
- Step 12:** Route the appropriate length of white dump valve cable (s) from the open 2 pin connector at row 8 (from step 11) to the 2 pin connector labeled RM UP DUMP on the 2940-162 installed in step 2.

KEY

■ = Dump Valve

□ = Planter Row Unit

Y = Y Harness

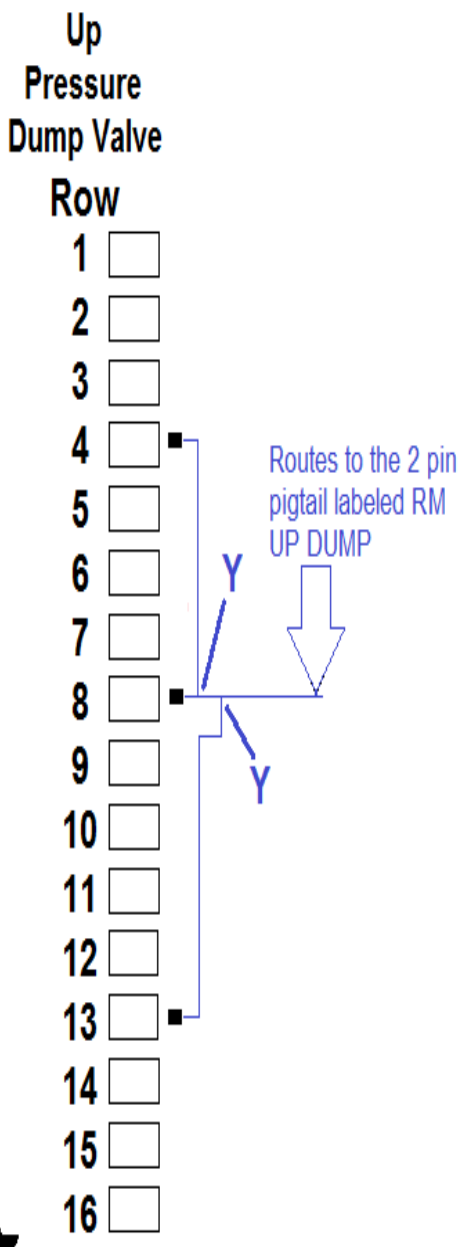
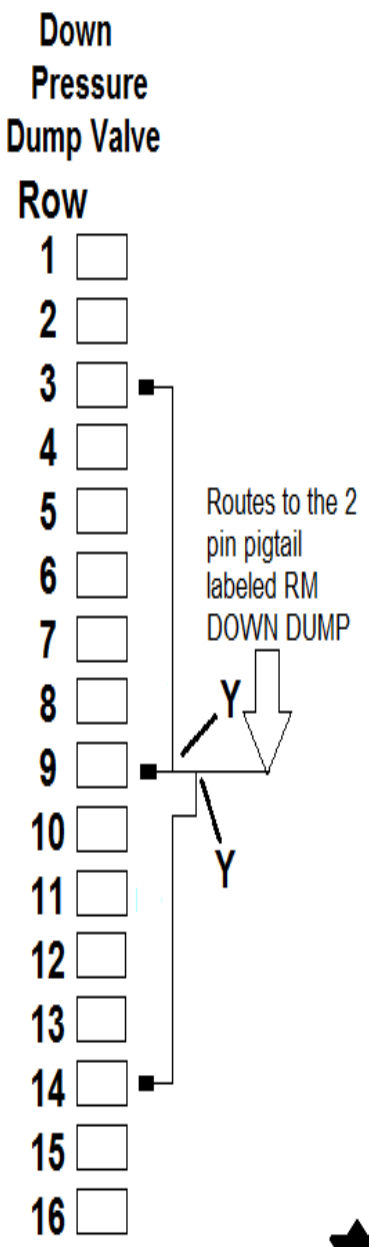

★ Aux 3 & Aux 4 on 2940-162 are not yet used ★

16 Row Airline Diagram

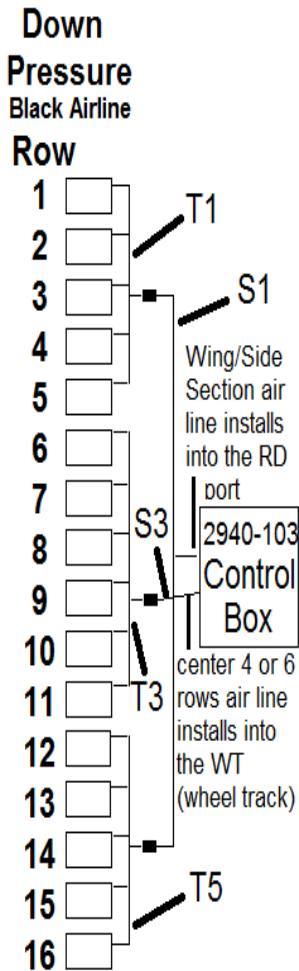

Step 1: T1 & T2 Route blue & black airline from row 1 to row 5. At row 5, install the black airline in the down pressure (larger) air bag & blue line in the up pressure (smaller) air bag. Trace both airline back to row 1 installing tees in each line at each row unit. Route & install blue airline from the up pressure air bag fitting to the tee in the up pressure (blue) circuit for that row. Route & install black airline from the down pressure air bag fitting to the tee in the down pressure (black) circuit for that row. At row 1, cut both airline to length & install each airline into the matching air bag.

Step 2: Install a tee in the T1 airline next to the dump valve or row 3. Route & install black airline from the tee in the T1 airline into the outlet port on the down pressure dump valve on row 3. Install a tee in the T2 airline next the up pressure dump valve on row 4. Route & install blue airline from tee in the T2 airline to the outlet port on the up pressure dump valve on row 4.

Step 3: T5 & T6 Route blue and black airline from row 16 to row 12. At row 12, install the black airline in the down pressure (larger) air bag & blue line in the up pressure (smaller) air bag. Trace both airline back to row 16 installing tees in each line at each row unit. Route & install blue airline from the up pressure air bag fitting to the tee in the up pressure (blue) circuit for that row. Route & install black airline from the down pressure air bag fitting to the tee in the down pressure (black) circuit for that row. At row 16, cut both airline to length and install each airline into the matching air bag.

Step 4: Install a tee in the T5 airline next to the dump valve on row 14. Route & install black airline from the tee in the T5 airline into the outlet port of the down pressure dump valve on row 14. Install a tee in the T6 airline next to the dump valve on row 13. Install & route blue airline from tee in T6 to the outlet port on the up pressure dump valve on row 13.

Step 5: T3 & T4 Route blue & black airline from row 6 to row 11. At row 11, install the black airline in the down pressure (larger) air bag & blue line in the up pressure (smaller) air bag. Trace both airline back to row 6 installing tees in each line at each row unit. Route & install blue airline from the up pressure air bag fitting to the tee in the up pressure (blue) circuit for that row. Route & install black airline from the down pressure air bag fitting to the tee in the down pressure (black) circuit for that row. At row 6, cut both airline to length & install each airline into the matching air bag.

Step 6: Install a tee in the T3 airline next to the dump valve on row 9. Route & install black airline from the tee in the T3 airline into the outlet port of the down pressure dump valve on row 9. Install a tee in the T4 airline next to the dump valve on row 8. Install & route blue airline from tee in T4 to the outlet port on the up pressure dump valve on row 8.

Step 7: S1 Route black airline from RD port of the 2940-103 control box to the nearest point on the main frame and install a tee. From each side of the tee, route black airline to the inlet port on the down pressure dump valve on rows 3 and 14. (follow the same routing path as the trunk lines)

Step 8: S2 Route blue airline from the RU port of the 2940-103 control box to the nearest point on the main frame and install a tee. Install a 6 inch piece of blue line into any remaining port of the tee. Install a second tee on the open end of the 6 inch piece of blue airline. This will give you 3 open ports on this circuit to use. Route & install blue airline from 2 of those ports to each inlet port on the up pressure dump valve on rows 4 and 13. Route & install blue airline from remaining open port on the tee to the inlet on the up pressure dump valve on row 8.

Step 9: S3 Route & install black airline from the WT port of the 2940-103 control box to the inlet of the down pressure dump valve on row 9

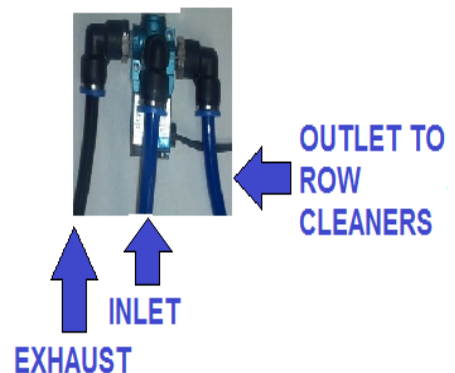
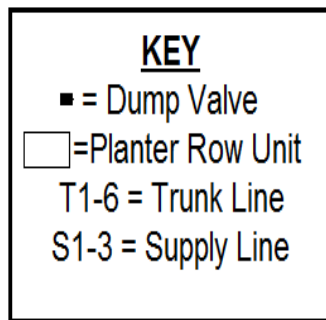
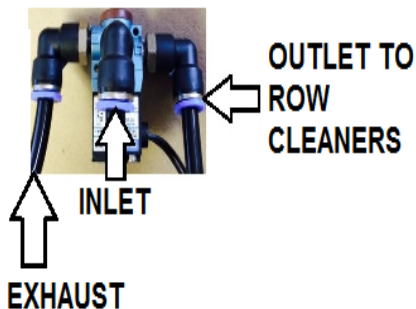
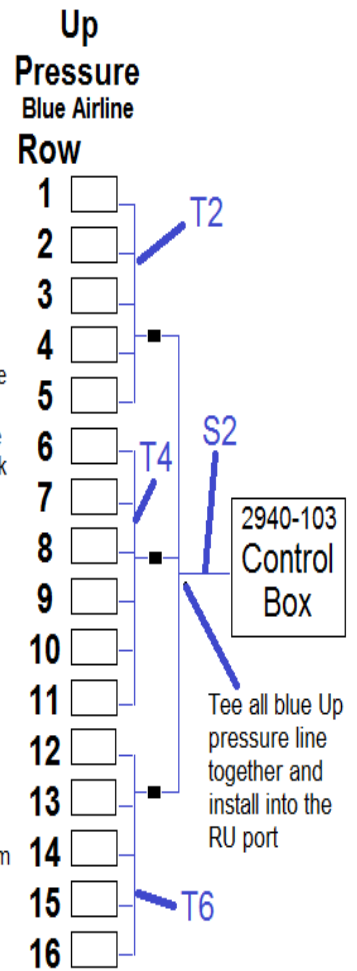

16/31 & 16/32 Split Row Dump Valve Diagram

KEY

■ = Dump Valve

□ = Planter Row Unit

Y = Y Harness

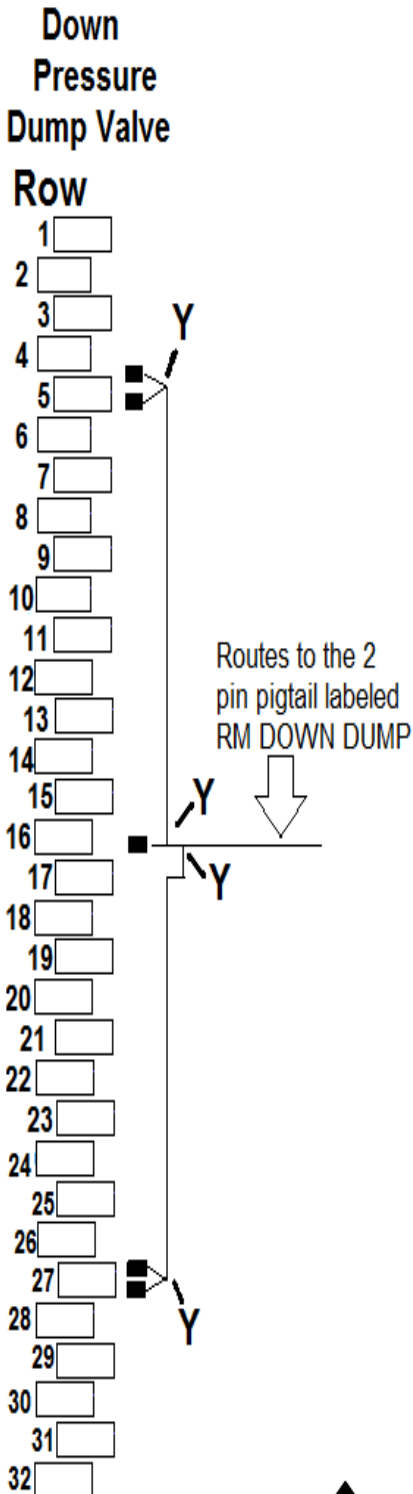

- Step 1:** Install 1 dump valve on each of the following rows: 6, 15, 16, & 26. Install 2 dump valves on each of the following rows: 5 & 27.
- Step 2:** Install the male 12 pin Deutsch connector of the 2940-162 dump valve cable into the **GRAY** female connector on the side of the 2940-103 control box.
- Step 3:** On rows 5 & 27, install a 2940-158 black Y harness to connect the dump valve's wiring harness leaving 1 open 2 pin connector on those rows.
- Step 4:** Install 2940-156 15ft black dump valve cable from the remaining open connector of the Y harnesses installed in step 3 on rows 5 & 27 and route to the dump valve on row 16 but don't install.
- Step 5:** Install a 2940-158 black Y harness connecting the 15ft black dump valve cables routed from rows 5 & 27 in step 4.
- Step 6:** Install another 2940-158 black Y harness connecting the Y harness from step 5 to the 2 pin connector on row 16, leaving one open 2 pin connector.
- Step 7:** Route the appropriate length of black dump valve cable(s) from the open 2 pin connector on the Y harness from step 6 to the 2 pin connector labeled RM DOWN DUMP on the 2940-162 dump valve harness installed in step 2.
- Step 8:** Route 2940-157 15ft white dump valve cables from dump valves on rows 6 and 26 to the dump valve on row 15 but don't install.
- Step 9:** Install a 2940-159 white Y harness connecting the white dump valve cables routed in step 8. Install a second white Y harness connecting row 15's dump valve to the white Y harness connecting rows 5 & 19, so that only 1 open 2 pin connector remains.
- Step 10:** Route the appropriate length of white dump valve cable(s) from the open 2 pin connector on the white Y harness installed in step 9 to the 2 pin connector labeled RM UP DUMP on the 2940-162 dump valve harness installed in step 2.

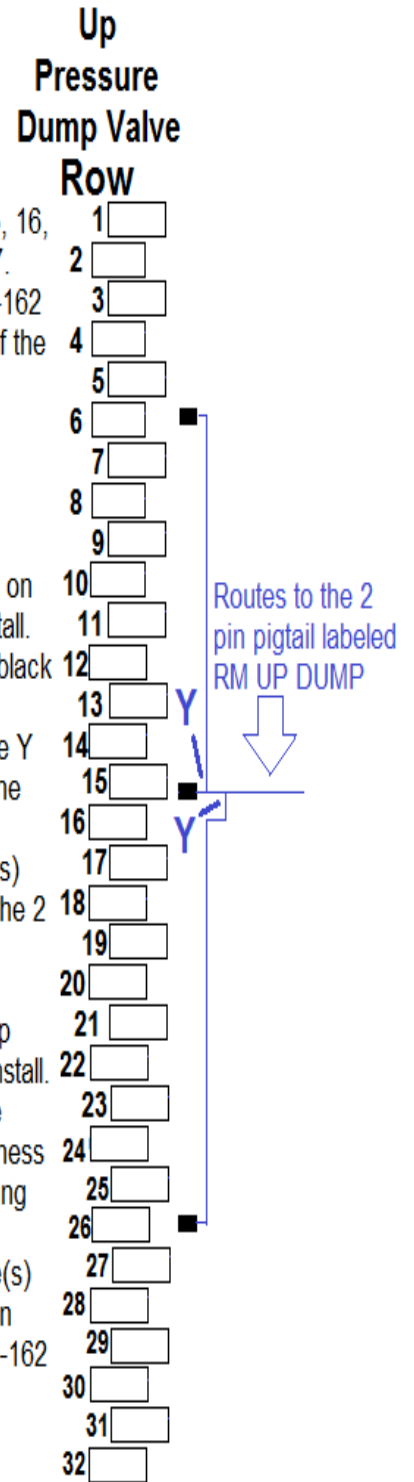

★ Aux 3 & Aux 4 on 2940-162 are not yet used ★

16/31 & 16/32 Split Row Airline Diagram

Down Pressure
Black Airline
on corn rows

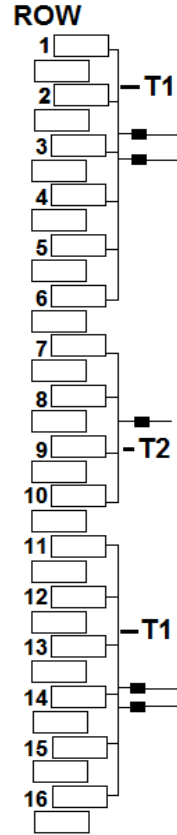

KEY

- = Dump Valve
- = Planter Row Unit
- = Ball Valve
- T1-6 = Trunk Line
- S1-3 = Supply Line

Up Pressure
Blue Airline
on corn rows

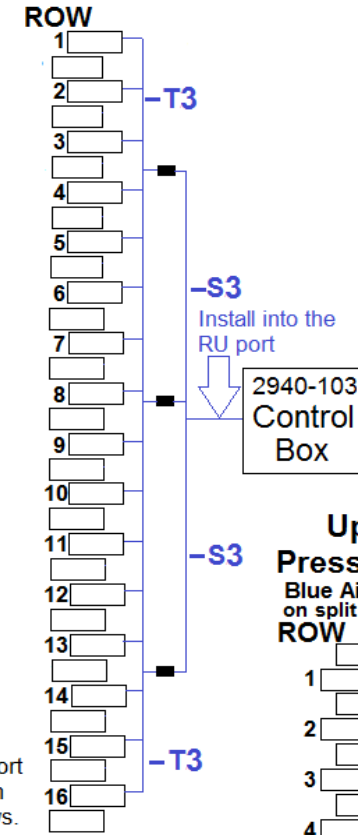

Down Pressure
Black Airline
on split rows

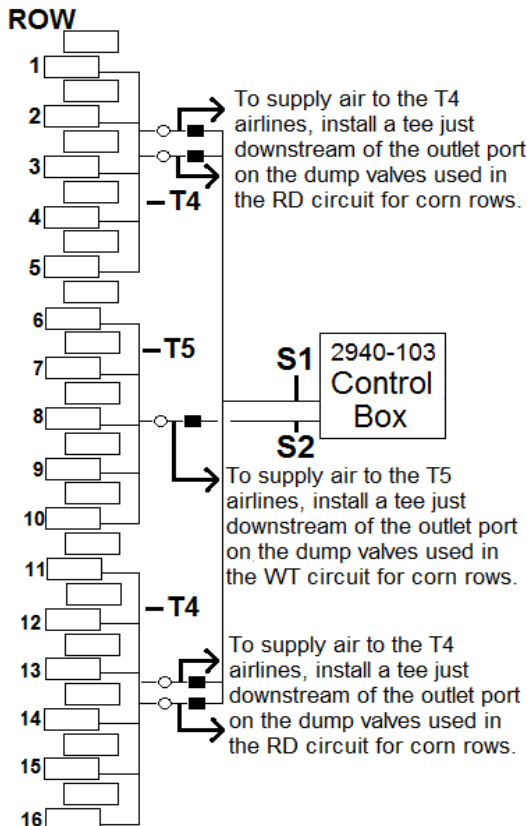

Up Pressure
Blue Airline
on split rows

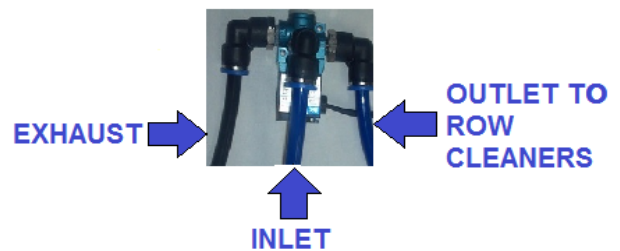
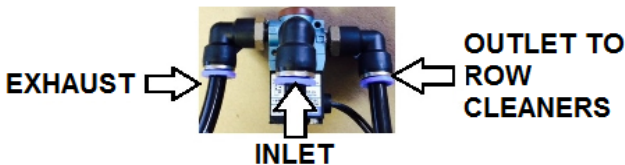
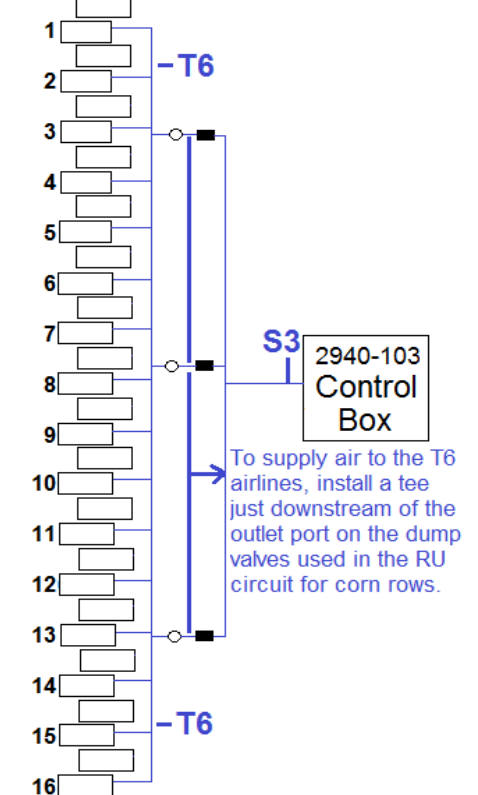

16/31 & 16/32 Split Row Airline Diagram Con't

- Step 1: T1** Route black airline from corn row 1 to corn row 6 & install the black airline into the down pressure air bag (larger) fitting. Trace this same airline back to corn row 1, installing tees at each corn row. Cut the black airline to length and install in the down pressure air bag fitting on corn row 1. Install an additional black airline in the down pressure air bag fitting on corn rows 2-5, cut the airline to length, & install in the tee for that row.
- Step 2: T1** Route black airline from corn row 16 to corn row 11 & install the black airline into the down pressure air bag (larger) fitting. Trace this same airline back to corn row 16, installing tees at each corn row. Cut the black airline to length & install the black airline in the down pressure air bag fitting on corn row 16. Install an additional black airline in the down pressure air bag fitting on corn rows 12-15, cut to the airline to length, & install in the tee for that row.
- Step 3: S1** Install a tee in the T1 airline next to each dump valve on corn row 3 & corn row 14 (4 tees total). Route & install black airline from the remaining open port of the tee to the outlet port of each dump valve on corn row 3 & corn row 14.
- Step 4: S1** Route black airline from the RD port of the 2940-103 control box to the center of the planter & install a tee. Route & install black airline from each open end of the tee to the inlet port of the furthest dump valve on corn row 3 & corn row 14. Install a tee at the other dump valve on corn row 3 & corn row 14, route black airline from the open port of the tee to the inlet port of the dump valve, & install
- Step 5: T2** Route black airline from corn row 7 to corn row 10 & install the black airline into the down pressure air bag (larger) fitting. Trace this same airline back to corn row 7, installing tees at each corn row. Cut the black airline to length & install in the down pressure air bag fitting on corn row 7. Install an additional black airline in the down pressure air bag fitting on corn rows 8 & 9, cut the airline to length, & install in the tee for that row.
- Step 6: S2** Install a tee in the black airline installed in the T2 airline installed in step 5 near the dump valve on row 16 (split row 8). Measure & cut black airline to length between the tee & the dump valve on row 16. Install the black airline into the tee & into the outlet port on the dump valve on row 13.
- Step 7: S2** Install black airline from the inlet port of the dump valve on row 16 (from step 6) to the WT port on the 2940-103 control box.
- Step 8: T3** Route & install blue airline from corn row 1 to corn row 16 & install the blue airline into the up pressure air bag (smaller) fitting. Trace this airline back to corn row 1, installing tees at each corn row. When returned to corn row 1, cut the blue airline to length & install into the up pressure air bag fitting. Install an additional blue airline into the up pressure air bag fitting on each corn row, cut to length, & install into the tee for that corn row.
- Step 9: S3** Install a tee into the T3 line (from step 8) next to the dump valves on rows 6, 15, & 26. Measure & cut blue airline to length between the tee & outlet port of the dump valves. Install the blue airline from the tee to the outlet port of each up pressure dump valve.
- Step 10: S3** Install blue airline from the inlet port on the dump valves on rows 6 & 26 & route to the dump valve on row 15. Install a tee connecting the blue airline routed from the dump valves on rows 6 & 26. Measure, cut, & install blue airline from the remaining open port of the tee to the inlet port of the dump valve on row 15. Install an additional tee in the blue airline between the dump valve on row 19 and the tee that connects row 19 & row 5's dump valves. Route blue airline from the remaining port of the tee to the RU port of the 2940-103 control box & install.
- Step 11: T4** Route black airline from split row 1 to split row 5 & install the black airline into the down pressure air bag (larger) fitting. Trace this same airline back to split row 1, installing tees at each split row. Cut the black airline to length & install in the down pressure air bag fitting on split row 1. Install an additional black airline in the down pressure air bag fitting on split rows 2-4 & cut to length to install in the tee for that row.
- Step 12: T4** Route black airline from split row 15/16 to split row 11 & install the black airline into the down pressure air bag (larger) fitting. Trace this same airline back to split row 15/16, installing a tee at split rows 12-14/15. Cut the black airline to length & install in the down pressure air bag fitting on split row 15/16. Install an additional black airline in the down pressure air bag fitting on split rows 12-14/15 & cut to length to install in the tee for that row.
- Step 13: S4.** Install a tee downstream of the outlet port on each dump valve on corn row 3. Install a 6 inch piece of black airline in the open port of each tee & a ball valve (2940-342) on the open end of each 6 inch piece of airline. Install a tee in the T4 airline installed in step 11 next to each dump valve on corn row 3. Cut black airline to length from each tee in the T4 airline to the open end of each ball valve & install. Install a tee downstream of the outlet port on each dump valve on corn row 14. Install a 6 inch piece of black airline in each tee & a ball valve on the open end of each 6 inch piece of airline. Install a tee in the T4 airline installed in step 12 next to each dump valve on corn row 14. Cut black airline to length from each tee to the open end of each ball valve & install.
- Step 14: T5** Route black airline from split row 6 to split row 10 & install into the down pressure air bag fitting on split row 10. Trace this same airline back to split row 6 installing a tee at split rows 7-9. At split row 6, cut the black airline to length & install into the down pressure air bag fitting. Install black airline from the down pressure air bag fitting on split rows 7-9, cut to length, & install into the tee installed for that row.
- Step 15: S5** Install a tee downstream of the outlet port on dump valve on row 16 (split row 8). Install a 6 inch piece of black airline in the tee & a ball valve on the open end of the 6 inch piece of airline. Install a tee in the T5 airline from step 14 next to the dump valve on split row 8. Install black airline from the tee to the open port of the ball valve.
- Step 16: T6** Route blue airline from split row 1 to split row 15/16 & install into the up pressure air bag fitting on split row 15/16. Trace this airline back to split row 1 installing a tee at each split row. When returned to split row 1, cut the blue airline to length, & install it in the airline into the up pressure air bag fitting. Install blue airline from the up pressure air bag fitting to the tee installed for that split row.
- Step 17: S6** Install a tee downstream of the outlet port on the dump valves on rows 6, 15, & 26. Install a 6 inch piece of blue airline in each tee & a ball valve on the open end of each 6 inch piece of blue airline. Install a tee in the T6 airline from step 16 next to each dump valve on rows 6, 15, & 26. Install blue airline from each tee to the open port of each ball valve.

24 Row Dump Valve Diagram

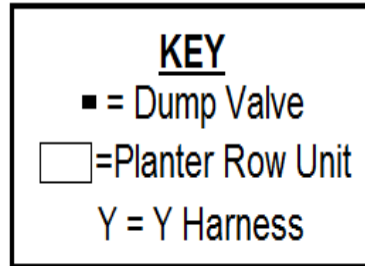

Down
Pressure
Dump Valve

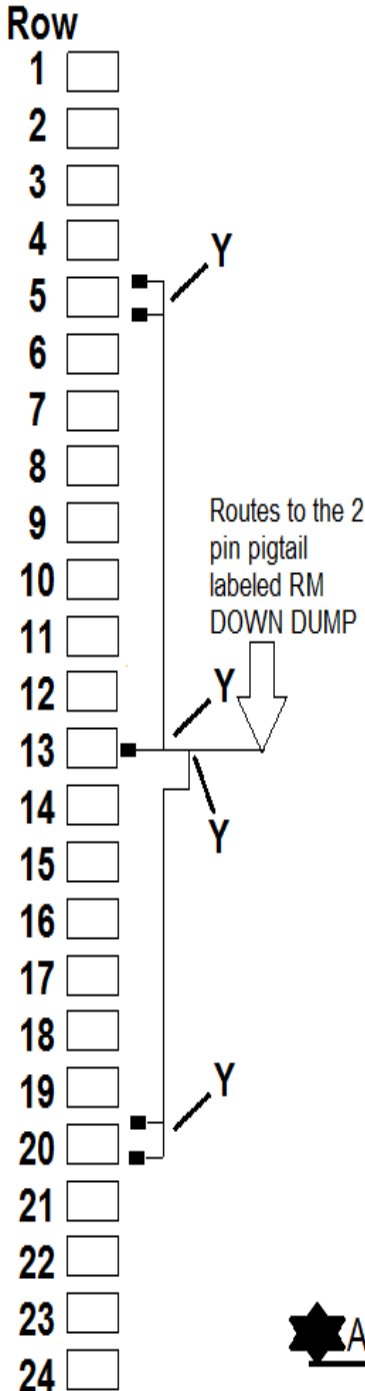

- Step 1:** Install 1 dump valve on each of the following rows: 6, 12, 13, & 19. Install 2 dump valves on each of the following rows: 5 & 20.
- Step 2:** Install the male 12 pin Deutsch connector of the 2940-162 dump valve cable into the **GRAY** female connector on the side of the 2940-103 control box.
- Step 3:** At row 5's dump valves, connect each dump valve's 2 pin cable using a 2940-161 black Y harness. Install a 2940-153 30ft black dump valve cable on the open end of the Y harness and route to row 13's dump valve but don't install.
- Step 4:** At row 20's dump valves, connect each dump valve's 2 pin cable using a 2940-161 black Y harness. Install a 2940-153 30ft black dump valve cable on the open end of the Y harness and route to row 13's dump valve but don't install.
- Step 5:** At row 13, use 1 black Y harnesses to connect the 30ft black dump valve cable routed from row 5 (step 3) and the 30ft black dump valve harness routed from row 20 (step 4). Use a second black Y harness to connect row 13's dump valve cable to the Y harness connecting row 5 and 20 leaving 1 open 2 pin connector.
- Step 6:** Route the appropriate length of black dump valve cable(s) from the open 2 pin connector at row 13 (from step 5) to the 2 pin connector labeled RM DOWN DUMP on the 2940-162 from step 2.
- Step 7:** At row 6's dump valve, connect the 2 pin connector of the dump valve to the mating 2 pin connector of the 2940-155 30ft white dump valve cable & route to the dump valve on row 12 but don't install. At row 19's dump valve, connect the 2 pin connector of the dump valve to the mating 2 pin connector of the 2940-155 30ft white dump valve cable and route to row 12 but don't install.
- Step 8:** At row 12, use a 2940-159 white Y harnesses to connect the white dump valve cable routed from the dump valve on row 6 & row 19 (in step 7) & a second 2940-159 white Y harness to connect the dump valve on row 12 to the Y harness used to connect the dump valves on row 6 & 19 so that only 1) 2 pin connector remains.
- Step 9:** Route the appropriate length of white dump valve cable(s) from the open 2 pin connector of the Y harness at row 12 (from step 8) to the 2 pin connector labeled RM UP DUMP on the 2940-162 from step 2.

★ Aux 3 & Aux 4 on 2940-162 are not yet used ★

Up
Pressure
Dump Valve

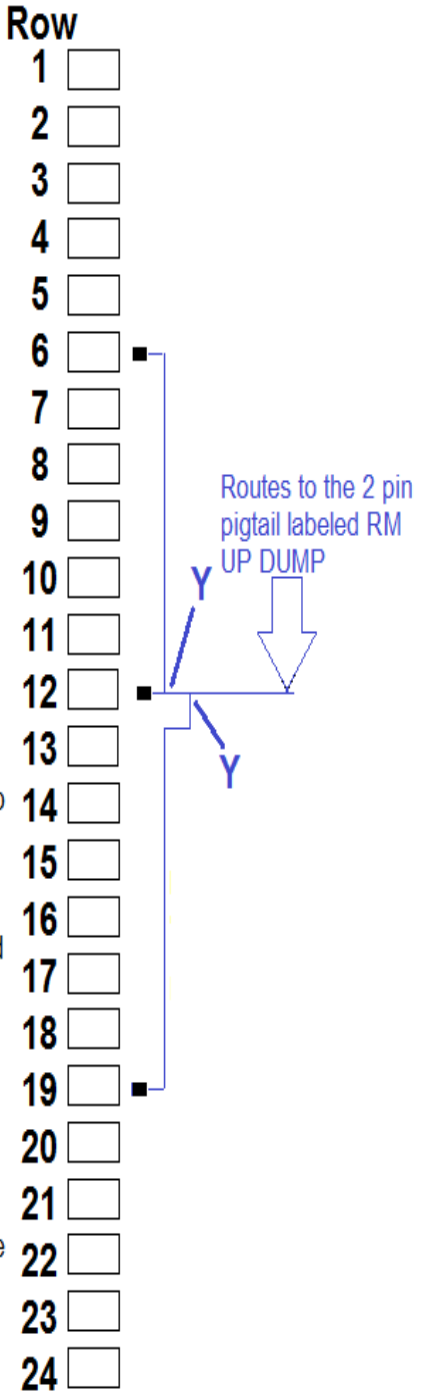

24 Row Airline Diagram

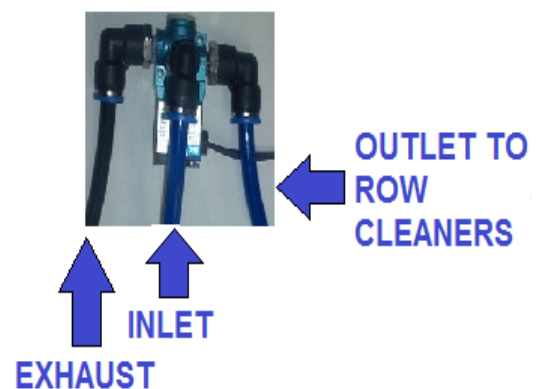
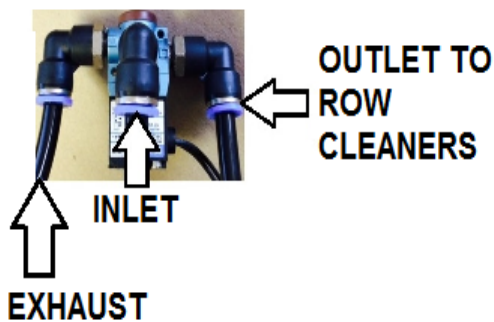
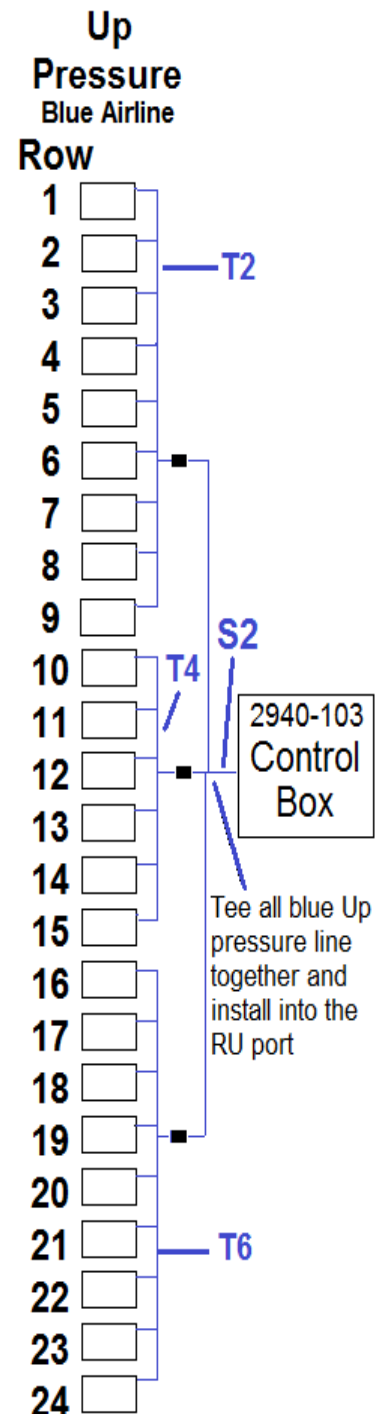
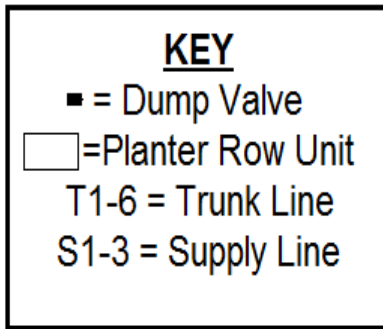
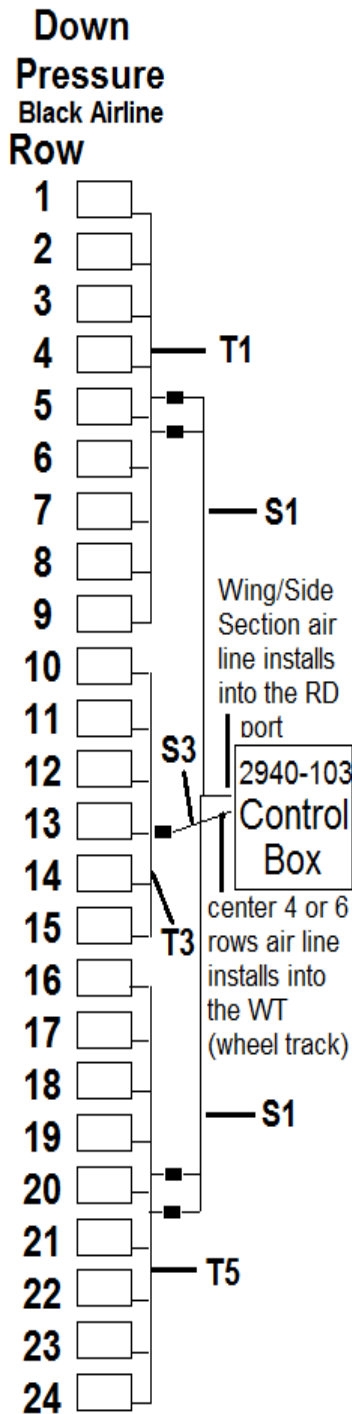

24 Row Airline Diagram Con't

Step 1:T1 & T2 Route blue & black airline from row 1 to row 9. At row 9, install the black airline in the down pressure (larger) air bag & blue line in the up pressure (smaller) air bag. Trace both airline back to row 1 installing tees at each row unit in each airline. Install blue airline from the up pressure air bag (smaller air bag) at each row to the tee in the up pressure (blue) circuit for that row. Install black airline from the down pressure air bag (larger air bag) at each row to the tee in the down pressure (black) circuit for that row. At row 1, cut both airlines to length & install each airline into the matching air bag.

Step 2: Install a tee in the T1 airline next to each down pressure dump valve on row 5. Install black airline from the outlet port on the down pressure dump valves on row 5 to the tee installed for that dump valve. Install a tee in the T2 airline next to the up pressure dump valve on row 6. Install blue airline from the outlet port on the up pressure dump valve on row 6 to the tee installed for that dump valve.

Step 3:T5 & T6 Route blue and black airline from row 24 to row 16. Install each airline into the matching air bag on row 16. Trace both airlines back to row 24 installing tees at each row unit in each airline. Install blue airline from the up pressure air bags to the tee in the up pressure airline for that row. Install black airline from the down pressure air bag to the tee in the down pressure airline for that row. At row 24, cut both airlines to length and install each airline into the matching air bag.

Step 4: Install a tee in the T5 airline next to each down pressure dump valve on row 20. Install black airline from the outlet port on the down pressure dump valves on row 20 to the tee installed for that dump valve. Install a tee in the T6 airline next to the up pressure dump valve on row 21. Install blue airline from the outlet port of the up pressure dump valve on row 21 to the tee installed for that dump valve.

Step 5:T3 &T4 Route blue and black airline from row 10 to row 15. Install each airline into the matching air bag on row 15. Trace both airlines back to row 10 installing tees at each row unit in each airline. Install blue airline from the up pressure air bags to the tee in the up pressure airline for that row. Install black airline from the down pressure air bag to the tee in the down pressure airline for that row. At row 10, cut both airlines to length and install each airline into the matching air bag.

Step 6: Install a tee in the T3 airline next to the dump valve on row 13. Install black airline from the outlet port on the down pressure dump valve on row 13 to the tee installed for that dump valve. Install a tee in the T4 airline next to the up pressure dump valve on row 12. Install blue airline from the outlet port of the up pressure dump valve to the tee installed for that dump valve.

Step 7:S1 Route black airline from RD port on the 2940-103 control box to the nearest point on the main frame and install a tee. From each side of the tee, route black airline to the inlet port on the furthest down pressure dump valve on rows 5 and 20 & install (follow the same routing path as the trunk lines). Install a tee into the S1 airline next to the other down pressure dump valves on rows 5 and 20, route black airline from the tee to the inlet port of each dump valve, & install.

Step 8:S2 Route blue airline from the RU port on the 2940-103 control box to the nearest point on the main frame and install a tee. Install a 6 inch piece of blue airline into one port of the tee. Install a second tee on the open end of the 6 inch piece of blue airline. This will give you 3 open ports on this circuit to use. Route & install blue airline from 2 of those ports to each inlet port on the up pressure dump valve on rows 6 and 19. Route & install blue airline from remaining open port on the tee to the inlet on the up pressure dump valve on row 12.

Step 9:S3 Route & install black airline from the WT port on the 2940-103 control box to the inlet of the down pressure dump valve on row 13.

32 Row Dump Valve Diagram

KEY

■ = Dump Valve

□ = Planter Row Unit

Y = Y Harness

Down
Pressure
Dump Valve

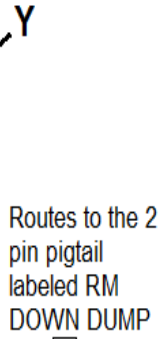
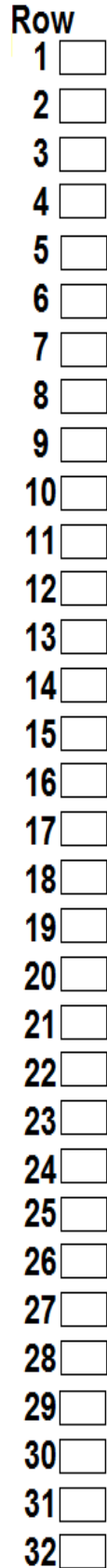

Step 1: Install 1 dump valve on each of the following rows: 5, 7, 10, 16, 17, 24, 26, & 28.

Step 2: Install the male 12 pin Deutsch connector of the 2940-162 dump valve cable into the **GRAY** female connector on the side of the 2940-103 control box.

Step 3: At row 5's dump valve, connect the 2 pin connector of the dump valve to the mating 2 pin connector of the 2940-156 15ft black dump valve cable & route to the dump valve on row 10 but don't install. At row 28's dump valve, connect the 2 pin connector of the dump valve to the mating 2 pin connector of the 2940-156 15ft black dump valve cable & route to the dump valve on row 24 but don't install.

Step 4: Connect the 2 pin cable of the dump valve on row 10 & the cable routed from row 5 from step 3 using a 2940-161 black Y harness. Connect the 2 pin cable of the dump valve on row 24 & the cable routed from row 28 from step 3 using a 2940-161 black Y harness.

Step 5: Install a 2940-154 30ft black dump valve harness in the remaining connector of the Y harness at row 10 & route to the dump valve on row 17 but don't install. Install a 2940-154 30ft dump valve harness in the remaining connector of the Y harness at row 24 & route to the dump valve on row 17 but don't install.

Step 6: At row 17, use one 2940-161 black Y harnesses to connect the black dump valve cable ran from each wing/side section of the planter (in step 5) and a second 2940-161 black Y harness connecting the Y harness installed at the beginning of this step to the dump valve on row 17 so that only 1) 2 pin connector remains.

Step 7: Route the appropriate length of black dump valve cable(s) from the open 2 pin connector at row 17 (from step 6) to the 2 pin connector labeled RM DOWN DUMP on the 2940-162 cable from step 2.

Step 8: At row 7's dump valve, connect the 2 pin connector of the dump valve to the mating 2 pin connector of the 2940-155 30ft white dump valve cable & route to the dump valve on row 16 but don't install. At row 26's dump valve, connect the 2 pin connector of the dump valve to the mating 2 pin connector of the 2940-155 30ft white dump valve cable & route to the dump valve on row 16 but don't install.

Step 9: At row 16, use 2) 2940-159 white Y harnesses to connect the white dump valve cable ran from each wing/side section of the plant (in step 8) & also the dump valve on row 16 so that only 1) 2 pin connector remains.

Step 10: Route the appropriate length of white dump valve cable(s) from the open 2 pin connector at row 16 (from step 9) to the 2 pin connector labeled RM UP DUMP on the 2940-162 from step 2

Up
Pressure
Dump Valve

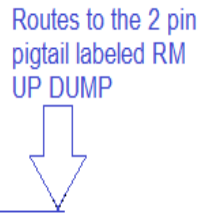
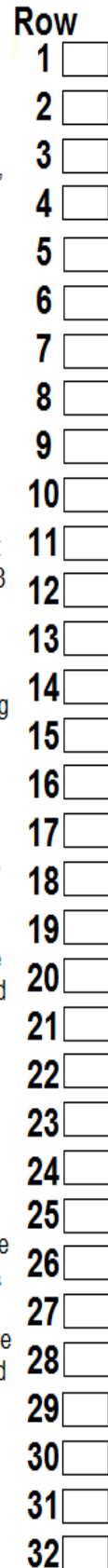

★ Aux 3 & Aux 4 on 2940-162 are not yet used ★

32 Row Airline Diagram

Down Pressure
Black Airline

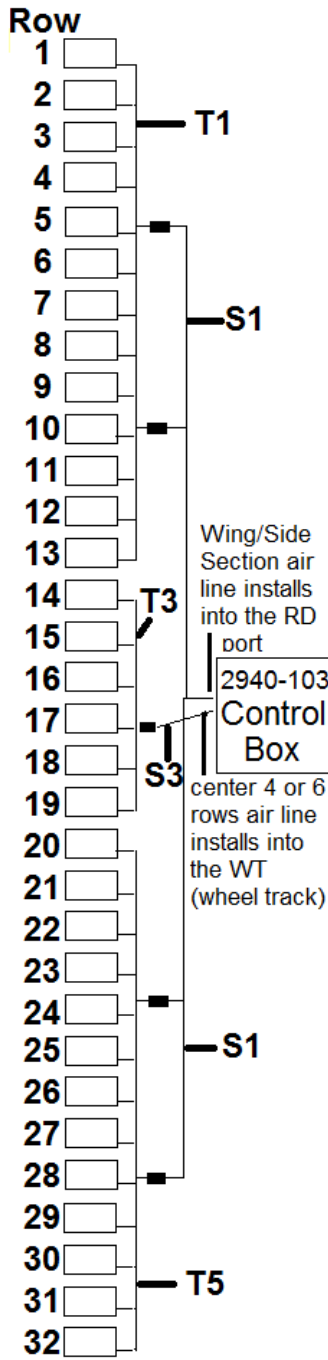

KEY

- = Dump Valve
- = Planter Row Unit
- T1-6 = Trunk Line
- S1-3 = Supply Line

Up Pressure
Blue Airline

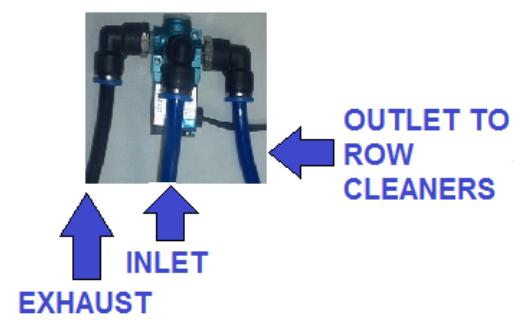
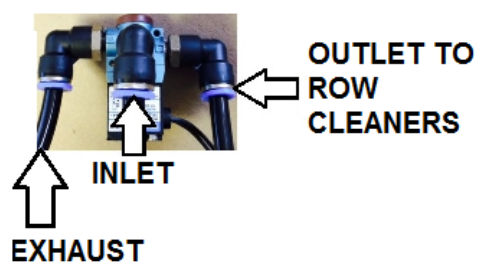
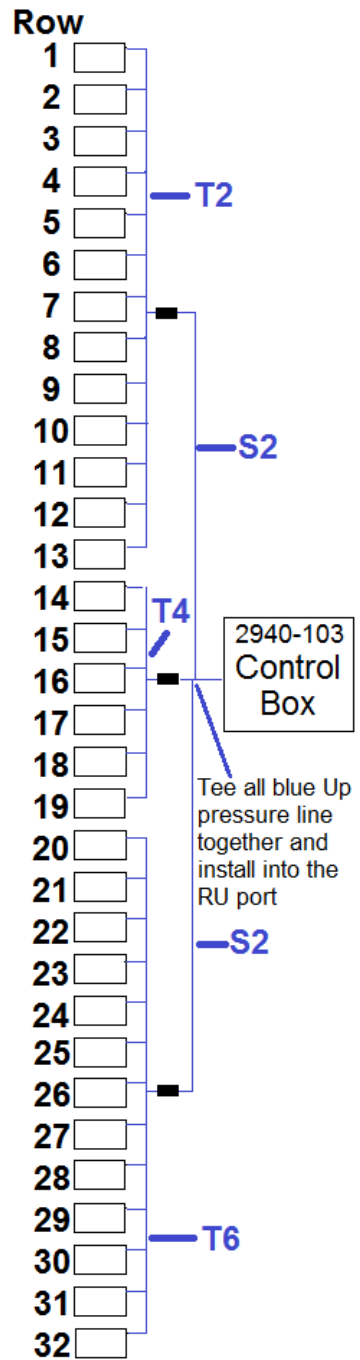

32 Row Airline Diagram Con't

Step 1:T1 & T2 Route blue & black airline from row 1 to row 13. At row 13, install the black airline in the down pressure (larger) air bag & blue line in the up pressure (smaller) air bag. Trace both airline back to row 1 installing tees in each airline at each row unit. Install blue airline from the up pressure air bag (smaller air bag) at each row to the tee in the up pressure (blue) circuit for that row. Install black airline from the down pressure air bag (larger air bag) at each row to the tee in the down pressure (black) circuit for that row. At row 1, cut both airlines to length & install each airline into the matching air bag.

Step 2: Install a tee in the T1 airline next to each down pressure dump valve on row 5 & row 10. Install black airline from the outlet port on the down pressure dump valves on row 5 & row 10 to the tee installed for that dump valve. Install a tee in the T2 airline next to the up pressure dump valve on row 7. Install blue airline from the outlet port on the up pressure dump valve on row 7 to the tee installed for that dump valve.

Step 3:T5 & T6 Route blue and black airline from row 32 to row 20. At row 20, install the black airline in the down pressure air bag & blue line in the up pressure air bag. Trace both airlines from row 20 back to row 32 installing tees in each airline at each row unit. Install blue airline from the up pressure air bag (smaller air bag) at each row to the tee in the up pressure (blue) circuit for that row. Install black airline from the down pressure air bag (larger air bag) at each row to the tee in the down pressure (black) circuit for that row. At row 32, cut both airlines to length and install each airline into the matching air bag.

Step 4: Install a tee in the T5 airline next to each down pressure dump valve on rows 24 & 28. Install black airline from the outlet port on the down pressure dump valves on rows 24 & 28 to each tee installed for that dump valve. Install a tee in the T6 airline next to the up pressure dump valve on row 26. Install blue airline from the outlet port of the up pressure dump valve on row 26 to the tee.

Step 5:T3 & T4 Route blue and black airline from row 14 to row 19. At row 19, install the black airline in the down pressure air bag & the blue airline in the up pressure air bag. Trace both airlines back to row 14 installing a tee in each airline at each row. Install blue airline from the up pressure air bag (smaller air bag) at each row to the tee in the up pressure (blue) circuit for that row. Install black airline from the down pressure air bag (larger air bag) at each row to the tee in the down pressure (black) circuit for that row. At row 14, cut both airlines to length and install each airline into the matching air bag.

Step 6: Install a tee in the T3 airline next to the down pressure dump valve on row 17. Install black airline from the tee in T3 airline into the outlet port on the down pressure dump valve on row 17. Install a tee in the T4 airline next to the dump valve on row 16. Install blue airline from the tee in T4 airline to the outlet port on the up pressure dump valve on row 16.

Step 7:S1 Route black airline from RD port of the 2940-103 control box to the nearest point on the main frame and install a tee. From each side of the tee, route black airline to the inlet port on the furthest down pressure dump valve on rows 5 & 28. (follow the same routing path as the trunk lines) Install a tee into the S1 airline next to the other down pressure dump valves on rows 10 and 24. Route & install black airline from tee to the inlet port on each of those dump valves.

Step 8:S2 Route blue airline from the RU port of the 2940-103 control box to the nearest point on the main frame & install a tee. Install a 6 inch piece of blue line into one port of tee. Install a second tee on the open end 6 inch piece of blue airline. This will give you 3 open ports on this circuit to use. Route & install blue airline from 2 of those ports to each inlet port on the up pressure dump valve on rows 7 & 26. Route & install blue airline from the remaining port on the tee to the inlet on the up pressure dump valve on row 16.

Step 9:S3 Route black airline from the WT port of the 2940-103 control box to the inlet port of the down pressure dump valve on row 17.

36 Row Dump Valve Diagram

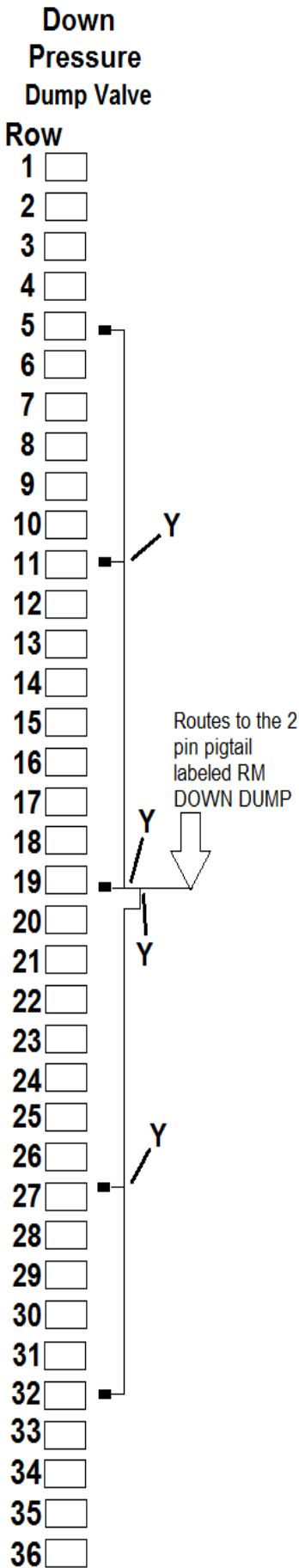
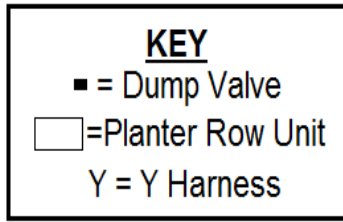

Step 1: Install 1 dump valve on each of the following rows: 5, 7, 11, 18, 19, 27, 29, & 32.

Step 2: Install the male 12 pin Deutsch connector of the 2940-162 dump valve cable into the **GRAY** female connector on the side of the 2940-103 control box.

Step 3: At row 5's dump valve, connect the 2 pin connector of the dump valve to the mating 2 pin connector of the 2940-156 15ft black dump valve cable & route to the dump valve on row 11 but don't install. At row 32's dump valve, connect the 2 pin connector of the dump valve to the mating 2 pin connector of the 2940-156 15ft black dump valve cable & route to the dump valve on row 27 but don't install.

Step 4: Connect the 2 pin cable of the dump valve on row 14 & the cable routed from row 5 in step 3 using a 2940-161 black Y harness. Connect the 2 pin cable of the dump valve on row 27 & the cable routed from row 32 in step 3 using a 2940-161 black Y harness.

Step 5: Install a 2940-154 30ft black dump valve harness in the remaining connector of the Y harness at row 11 & route to the dump valve on row 19 but don't install. Install a 2940-154 30ft black dump valve harness in the remaining connector of the Y harness at row 27 & route to the dump valve on row 19 but don't install.

Step 6: At row 19, use 2) 2940-161 black Y harnesses to connect the black dump valve cable ran from each wing/side section of the planter (in step 5) and also the dump valve on row 19 so that only 1) 2 pin connector remains.

Step 7: Route the appropriate length of black dump valve cable(s) from the open 2 pin connector at row 19 (from step 6) to the 2 pin connector labeled RM DOWN DUMP on the 2940-162 cable from step 2.

Step 8: At row 7's dump valve, connect the 2 pin connector of the dump valve to the mating 2 pin connector of the 2940-155 30ft white dump valve cable & route to the dump valve on row 18 but don't install. At row 29's dump valve, connect the 2 pin connector of the dump valve to the mating 2 pin connector of the 2940-155 30ft white dump valve cable & route to the dump valve on row 18 but don't install.

Step 9: At row 18, use 2) 2940-159 white Y harnesses to connect the white dump valve cable ran from each wing/side section of the planter (in step 8) & also the dump valve on row 18 so that only 1) 2 pin connector remains.

Step 10: Route the appropriate length of white dump valve cable(s) from the open 2 pin connector at row 18 (from step 9) to the 2 pin connector labeled RM UP DUMP on the 2940-162 from step 2.

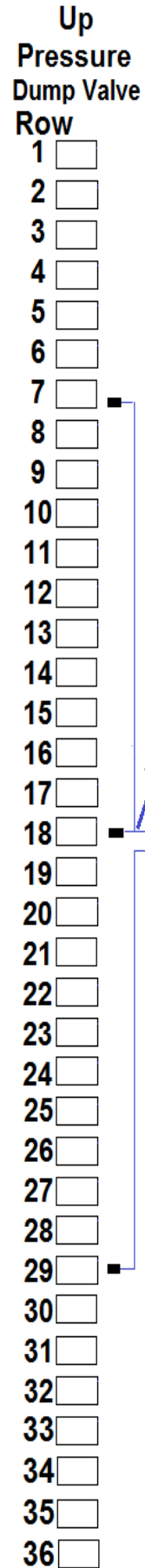

★ Aux 3 & Aux 4 on 2940-162 are not yet used ★

36 Row Airline Diagram

KEY

- = Dump Valve
- = Planter Row Unit
- T1-6 = Trunk Line
- S1-3 = Supply Line

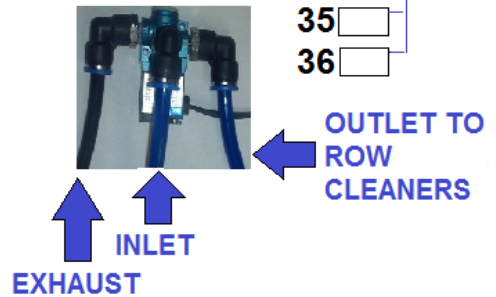
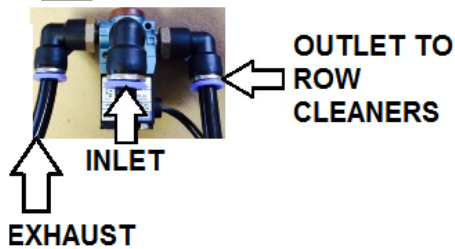
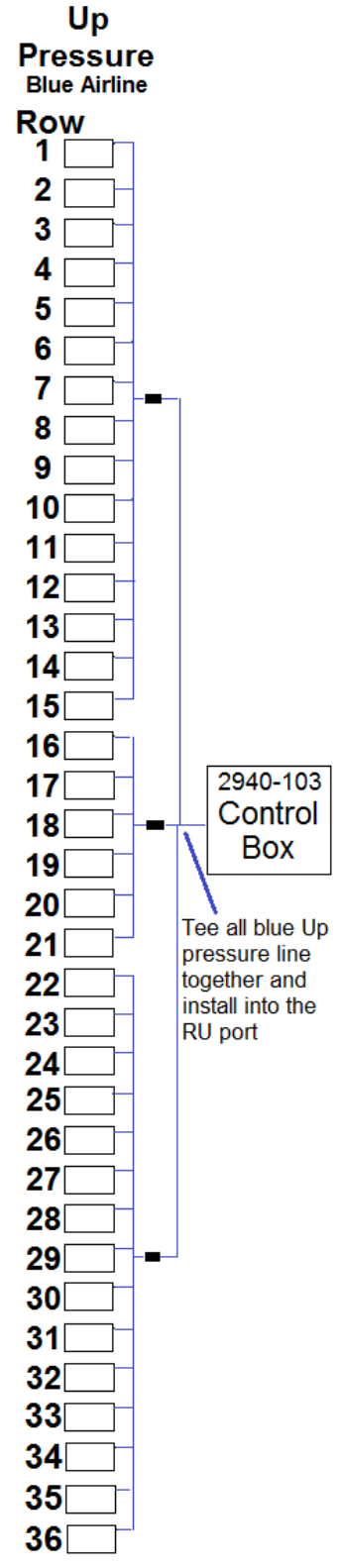
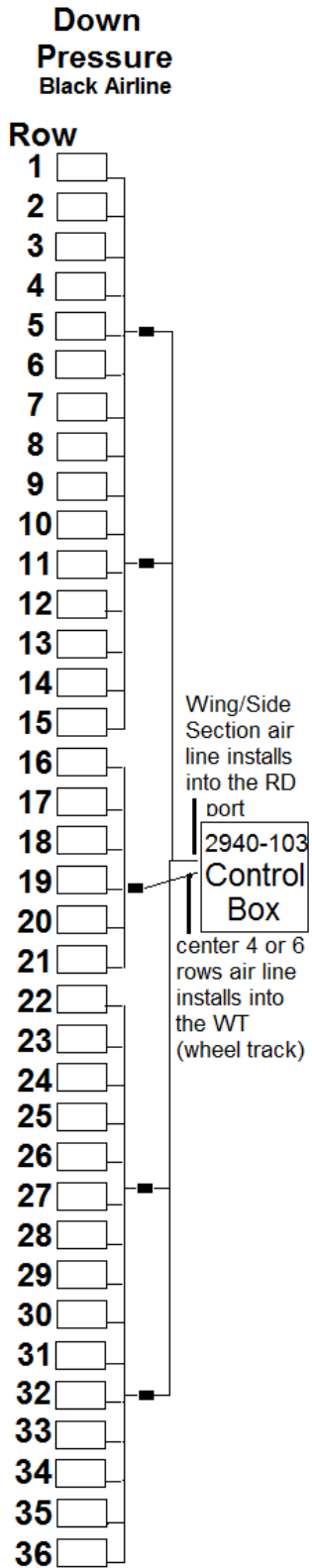

36 Row Airline Diagram Con't

Step 1:T1 & T2 Route blue & black airline from row 1 to row 15. At row 15, install the black airline in the down pressure (larger) air bag & blue line in the up pressure (smaller) air bag. Trace both airline back to row 1 installing tees in each airline at each row unit. Install blue airline from the up pressure air bag (smaller air bag) at each row to the tee in the up pressure (blue) circuit for that row. Install black airline from the down pressure air bag (larger air bag) at each row to the tee in the down pressure (black) circuit for that row. At row 1, cut both airlines to length & install airline into the matching air bag.

Step 2: Install a tee in the T1 airline next to each down pressure dump valve on rows 5 & 11. Install black airline from the outlet port on the down pressure dump valves on rows 5 & 11 to the tee for that dump valve. Install a tee in the T2 airline next to the up pressure dump valve at row 7. Install blue airline from the outlet port on the up pressure dump valve to the tee for that dump valve.

Step 3:T5 & T6 Route blue and black airline from row 36 to row 22. Install each airline into the matching air bag on row 20. Trace both airlines back to row 36 installing tees in each airline at each row. Install blue airline from the up pressure air bag (smaller air bag) at each row to the tee in the up pressure (blue) circuit for that row. Install black airline from the down pressure air bag (larger air bag) at each row to the tee in the down pressure (black) circuit for that row. At row 36, cut both airlines to length & install each airline into the matching air bag.

Step 4: Install a tee in the T5 airline next to each down pressure dump valve on rows 27 & 32. Install black airline from the outlet port of the down pressure dump valves on row 27 & 32 to the tee for that dump valve. Install a tee in the T6 airline next to the up pressure dump valve on row 29. Install blue airline from the outlet port of the up pressure dump valve to the tee for that dump valve.

Step 5:T3 &T4 Route blue and black airline from row 16 to row 21. Install each airline at row 21 into the matching air bags. Trace both airlines back to row 16 installing tees in each airline at each row. Install blue airline from the up pressure air bag (smaller air bag) at each row to the tee in the up pressure (blue) circuit for that row. Install black airline from the down pressure air bag (larger air bag) at each row to the tee in the down pressure (black) circuit for that row. At row 16, cut both airline to length and install each airline into the matching air bag.

Step 6: Install a tee in the T3 airline next to the dump valve on row 19. Install black airline from the outlet port of the down pressure dump valve on row 19 to the tee for that dump valve. Install a tee in the T4 airline next to the dump valve on row 18. Install blue airline from the outlet port of the up pressure dump valve on row 18 to the tee for that dump valve.

Step 7:S1 Route black airline from RD port of the 2940-103 control box to the nearest point on the main frame & install a tee. From each side of the tee, route black airline to the inlet port on the furthest down pressure dump valve on rows 5 and 32. (follow the same routing path as the trunk lines) Install a tee into the S1 airline next to the other down pressure dump valves on rows 11 and 27. Install black airline from inlet port of each dump valve to the tee for that dump valve.

Step 8:S2 Route blue airline from the RU port of the 2940-103 control box to the nearest point on the main frame & install a tee. Install a 6 inch piece of blue airline into one port of tee. Install a second tee on the open end 6 inch piece of blue airline. This will give you 3 open ports on this circuit to use. Route & install blue airline from 2 of those ports to each inlet port on the up pressure dump valve on rows 7 & 29. Route & install blue airline from remaining port on the tee to the inlet on the up pressure dump valve on row 18.

Step 9:S3 Route & install black airline from the WT port of the 2940-103 control box to the inlet of the down pressure dump valve on row 19.

48 Row Dump Valve Diagram

Down
Pressure
Dump Valve
Row

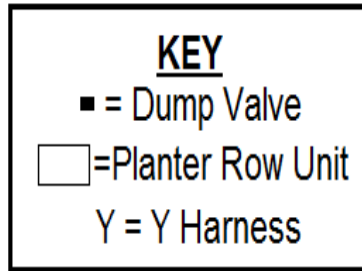

Up
Pressure
Dump Valve
Row

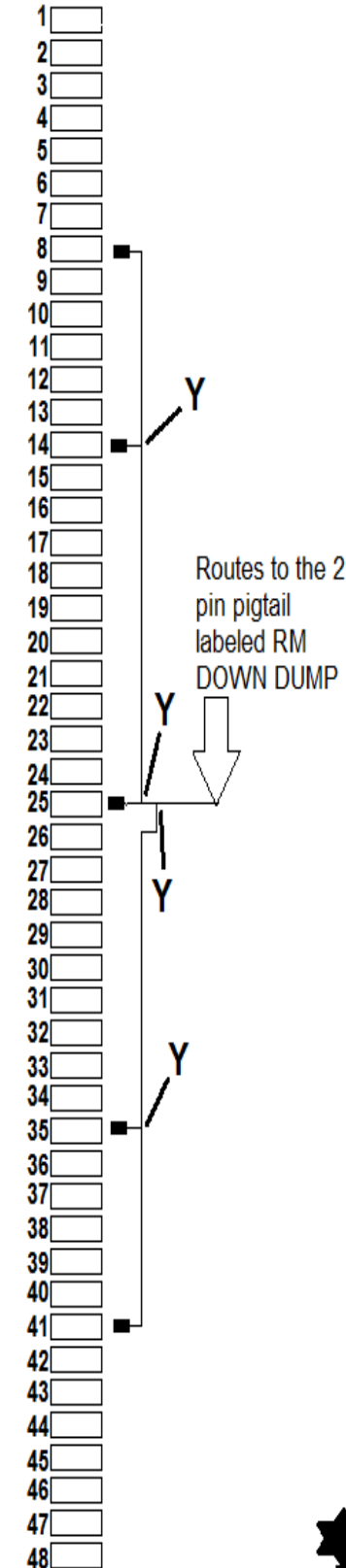

Step 1: Install 1 dump valve on each of the following rows: 8, 12, 14, 24, 25, 35, 36, & 41.

Step 2: Install the male 12 pin Deutsch connector of the 2940-162 dump valve cable into the **GRAY** female connector on the side of the 2940-103 control box.

Step 3: At row 8's dump valve, connect the 2 pin connector of the dump valve to the mating 2 pin connector of the 2940-156 15ft black dump valve cable & route to the dump valve on row 14 but don't install. At row 41's dump valve, connect the 2 pin connector of the dump valve to the mating 2 pin connector of the 2940-156 15ft black dump valve cable & route to the dump valve on row 35 but don't install.

Step 4: Connect the 2 pin cable of the dump valve on row 14 & the cable routed from row 8 in step 3 using a 2940-161 black Y harness. Connect the 2 pin cable of the dump valve on row 35 & the cable routed from row 41 in step 3 using a 2940-161 black Y harness.

Step 5: Install a 2940-154 30ft black dump valve harness in the remaining connector of the Y harness at row 14 & route to the dump valve on row 25 but don't. Install a 2940-154 30ft black dump valve harness in the remaining connector of the Y harness at row 35 & route to the dump valve on row 25 but don't install.

Step 6: At row 25, use 2) 2940-161 black Y harnesses to connect the black dump valve cable ran from each wing/side section of the planter (in step 5) and also the dump valve on row 25 so that only 1) 2 pin connector remains.

Step 7: Route the appropriate length of black dump valve cable(s) from the open 2 pin connector at row 25 (from step 6) to the 2 pin connector labeled RM DOWN DUMP on the 2940-162 cable from step 2.

Step 8: At row 12's dump valve, connect the 2 pin connector of the dump valve to the mating 2 pin connector of the 2940-155 30ft white dump valve cable & route to the dump valve on row 24 but don't install. At row 36's dump valve, connect the 2 pin connector of the dump valve to the mating 2 pin connector of the 2940-155 30ft white dump valve cable & route to the dump valve on row 24 but don't install.

Step 9: At row 24, use 2) 2940-159 white Y harnesses to connect the white dump valve cable ran from each wing/side section of the plant (in step 8) & also the dump valve on row 24 so that only 1) 2 pin connector remains.

Step 10: Route the appropriate length of white dump valve cable(s) from the open 2 pin connector at row 24 (from step 9) to the 2 pin connector labeled RM UP DUMP on the 2940-162 from step 2.

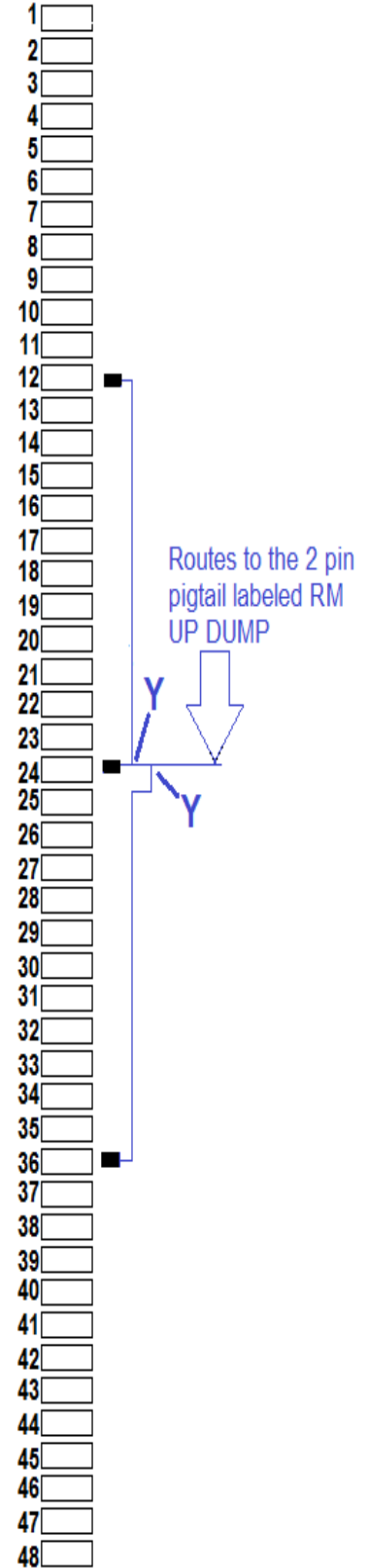

★ Aux 3 & Aux 4 on 2940-162 are not yet used ★

48 Row Airline Diagram

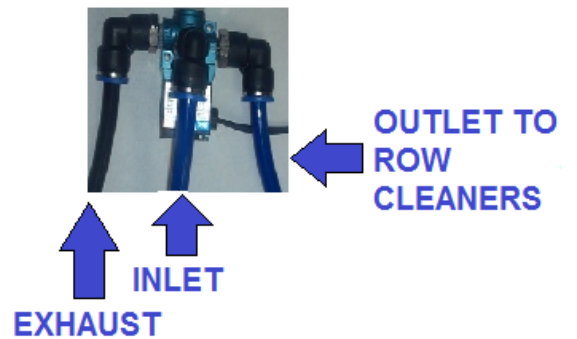
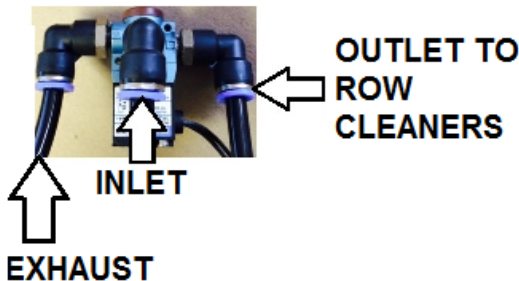
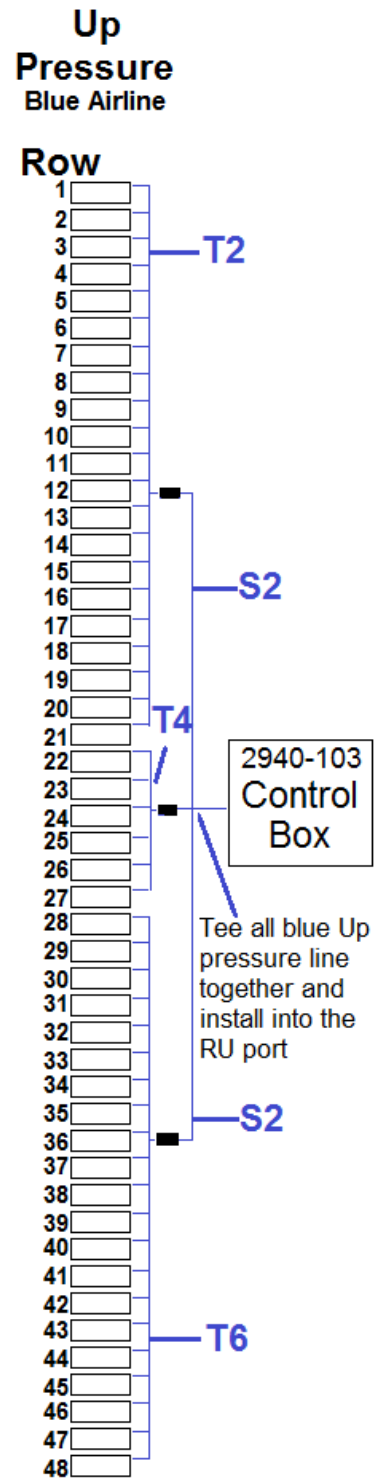
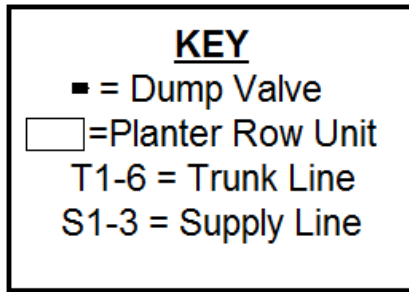
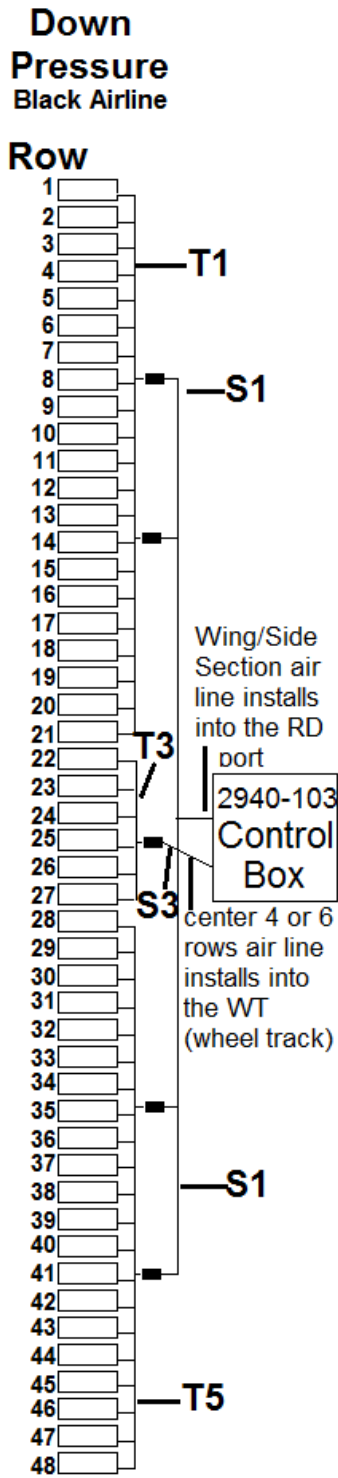

48 Row Airline Diagram Con't

Step 1:T1 & T2 Route blue & black airline from row 1 to row 21. At row 21, install the black airline in the down pressure (larger) air bag & blue line in the up pressure (smaller) air bag. Trace both airline back to row 1 installing tees in each airline at each row unit. Install blue airline from the up pressure air bag (smaller air bag) at each row to the tee in the up pressure (blue) circuit for that row. Install black airline from the down pressure air bag (larger air bag) at each row to the tee in the down pressure (black) circuit for that row. At row 1, cut both airlines to length & install each airline into the matching air bag.

Step 2: Install a tee in the T1 airline next to each down pressure dump valve on rows 8 & 14. Install black airline from the outlet port on the down pressure dump valves on rows 8 & 14 to the tee for that dump valve. Install a tee in the T2 airline next to each up pressure dump valve at row 12. Install blue airline from the outlet port on the up pressure dump valves on row 12 to the tee for that dump valve.

Step 3:T5 & T6 Route blue & black airline from row 48 to row 28. At row 28, install the black airline in the down pressure (larger) air bag & blue airline in the up pressure (smaller) air bag. Trace both airlines back to row 48 installing tees in each airline at each row unit. Install blue airline from the up pressure air bag (smaller air bag) at each row to the tee in the up pressure (blue) circuit for that row. Install black airline from the down pressure air bag (larger air bag) at each row to the tee in the down pressure (black) circuit for that row. At row 48, cut both airlines to length & install each airline into the matching air bag.

Step 4: Install a tee in the T5 airline next to each down pressure dump valve on rows 35 & 41. Install black airline from the outlet port of each down pressure dump valve to each tee for that dump valve. Install a tee in the T6 airline next to the up pressure dump valve at row 36. Install blue airline from the outlet port on the up pressure dump valve on row 36 to the tee for that dump valve.

Step 5:T3 & T4 Route blue & black airline from row 22 to row 27. At row 27, install the black airline into the down pressure (larger) air bag & the blue airline in the up pressure (smaller) air bag. Trace both airlines back to row 22 installing tees in each airline at each row unit. Install blue airline from the up pressure air bag (smaller air bag) at each row to the tee in the up pressure (blue) circuit for that row. Install black airline from the down pressure air bag (larger air bag) at each row to the tee in the down pressure (black) circuit for that row. At row 22, cut both airlines to length and install each airline into the matching air bag.

Step 6: Install a tee in the T3 airline next to the down pressure dump valve on row 25. Install black airline from the outlet port of the dump valve to the tee for that dump valve. Install a tee in the T4 airline next to the up pressure dump valve on row 24. Install blue airline from the outlet port on the up pressure dump valve on row 24 to the tee for that dump valve.

Step 7:S1 Route black airline from RD port of the 2940-103 control box to the nearest point on the main frame & install a tee. From each side of the tee, route & install black airline to the inlet port on the furthest down pressure dump valve on rows 8 & 41. (follow the same routing path as the trunk lines) Install a tee into the S1 airline next to the other down pressure dump valves on rows 14 & 35. Install black airline from the inlet port of each dump valve to the tee for that dump valve.

Step 8:S2 Route blue airline from the RU port of the 2940-103 control box to the nearest point on the main frame & install a tee. Install a 6 inch piece of blue line into one port of tee. Install a second tee on the open end 6 inch piece of blue airline. This will give you 3 open ports on this circuit to use. Route & install blue airline from 2 of those ports to each inlet port on the up pressure dump valve on rows 12 & 36. Route & install blue airline from remaining port on the tee to the inlet on the up pressure dump valve on row 24.

Step 9:S3 Route & install black airline from the WT port of the 2940-103 control box to the inlet of the down pressure dump valve on row 25.

54 Row Dump Valve Diagram

Down
Pressure
Dump Valve
Row

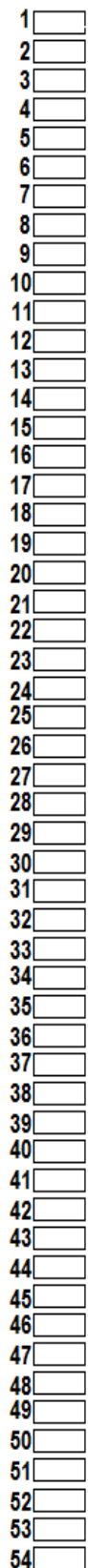

KEY

■ = Dump Valve

□ = Planter Row Unit

Y = Y Harness

Up
Pressure
Dump Valve
Row

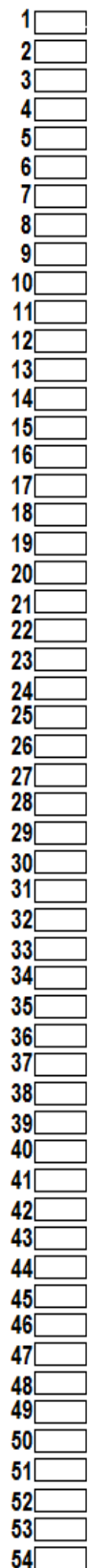

Step 1: Install 1 dump valve on each of the following rows: 9, 13, 18, 27, 28, 39, 41, & 48.

Step 2: Install the male 12 pin Deutsch connector of the 2940-162 dump valve cable into the GRAY female connector on the side of the 2940-103 control box.

Step 3: At row 9's dump valve, connect the 2 pin connector of the dump valve to the mating 2 pin connector of the 2940-156 15ft black dump valve cable & route to the dump valve on row 18 but don't install. At row 48's dump valve, connect the 2 pin connector of the dump valve to the mating 2 pin connector of the 2940-156 15ft black dump valve cable & route to the dump valve on row 39 but don't install.

Step 4: Connect the 2 pin cable of the dump valve on row 18 & the cable routed from row 9 using a 2940-161 black Y harness. Connect the 2 pin cable of the dump valve on row 39 & the cable routed from row 48 using a 2940-161 black Y harness.

Step 5: Install a 2940-154 30ft black dump valve harness in the remaining connector of the Y harness at row 18 from step 4 & route to the dump valve on row 28 but don't install. Install a 2940-154 30ft black dump valve harness in the remaining connector of the Y harness at row 39 from step 4 & route to the dump valve on row 28 but don't install.

Step 6: At row 28, use 2) 2940-161 black Y harnesses to connect the black dump valve cable ran from each wing/side section of the planter (in step 5) and also the dump valve on row 28 so that only 1) 2 pin connector remains.

Step 7: Route the appropriate length of black dump valve cable(s) from the open 2 pin connector at row 28 (from step 6) to the 2 pin connector labeled RM DOWN DUMP on the 2940-162 cable from step 2.

Step 8: At row 13's dump valve, connect the 2 pin connector of the dump valve to the mating 2 pin connector of the 2940-155 30ft white dump valve cable & route to the dump valve on row 27 but don't install. At row 41's dump valve, connect the 2 pin connector of the dump valve to the mating 2 pin connector of the 2940-155 30ft white dump valve cable & route to the dump valve on row 27 but don't install.

Step 9: At row 27, use 2) 2940-159 white Y harnesses to connect the white dump valve cable ran from each wing/side section of the plant (in step 8) & also the dump valve on row 27 so that only 1) 2 pin connector remains.

Step 10: Route the appropriate length of white dump valve cable(s) from the open 2 pin connector at row 27 (from step 9) to the 2 pin connector labeled RM UP DUMP on the 2940-162 from step 2.

★ Aux 3 & Aux 4 on 2940-162 are not yet used ★

54 Row Airline Diagram

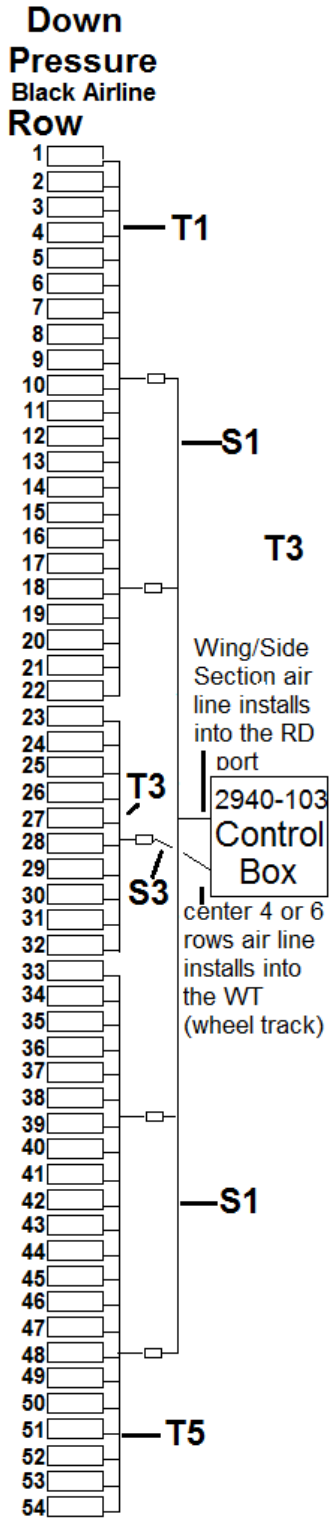

KEY

- = Dump Valve
- = Planter Row Unit
- T1-6 = Trunk Line
- S1-3 = Supply Line

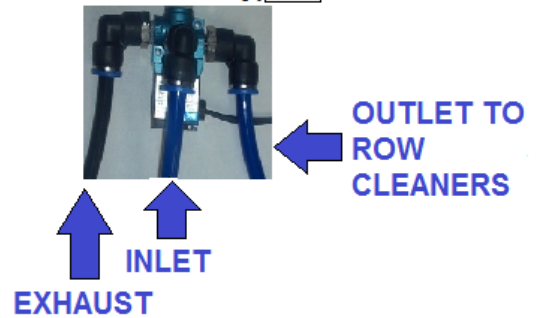
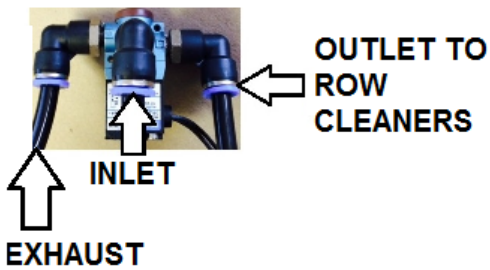
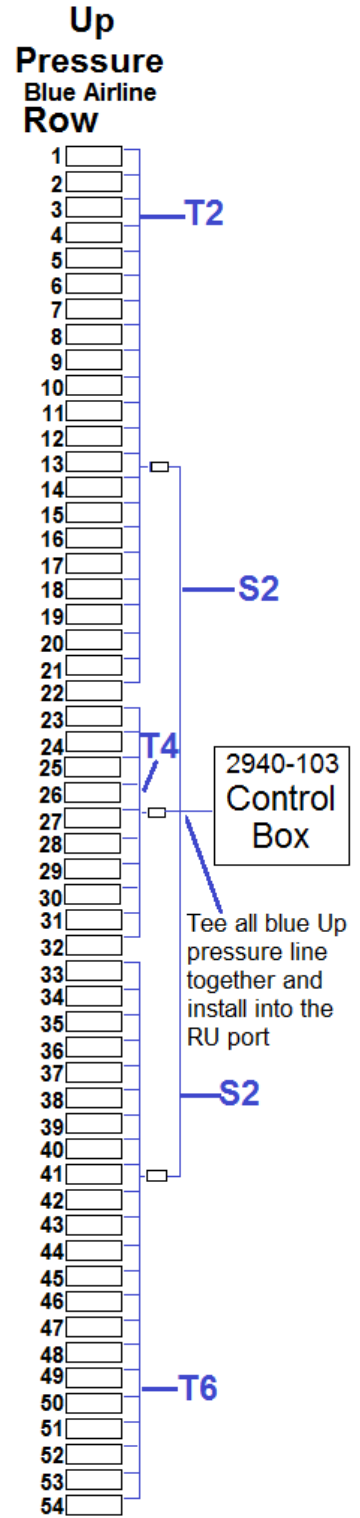

54 Row Airline Diagram Con't

Step 1:T1 & T2 Route blue & black airline from row 1 to row 22. At row 22, install the black airline in the down pressure (larger) air bag & blue line in the up pressure (smaller) air bag. Trace both airline back to row 1 installing tees in each airline at each row unit. Install blue airline from the up pressure air bag (smaller air bag) at each row to the tee in the up pressure (blue) circuit for that row. Install black airline from the down pressure air bag (larger air bag) at each row to the tee in the down pressure (black) circuit for that row. At row 1, cut both airlines to length & install each airline into the matching air bag.

Step 2: Install a tee in the T1 airline next to each down pressure dump valve on rows 10 & 18. Install black airline from the outlet port on the down pressure dump valves on rows 10 & 18 to the tee for that dump valve. Install a tee in the T2 airline next to the up pressure dump valve at row 13. Install blue airline from the outlet port on the up pressure dump valve on row 13 to the tee for that dump valve.

Step 3:T5 & T6 Route blue and black airline from row 54 to row 33. At row 33, install the black airline in the down pressure (larger) air bag & blue airline in the up pressure (smaller) air bag. Trace both airlines back to row 54 installing a tee in each airline at each row unit. Install blue airline from the up pressure air bag (smaller air bag) at each row to the tee in the up pressure (blue) circuit for that row. Install black airline from the down pressure air bag (larger air bag) at each row to the tee in the down pressure (black) circuit for that row. At row 54, cut both airlines to length & install each airline into the matching air bag.

Step 4: Install a tee in the T5 airline next to each down pressure dump valve on rows 39 & 48. Install black airline from the outlet port of each down pressure dump valve on rows 39 & 48 to the tee for that dump valve. Install a tee in the T6 airline next to the up pressure dump valve on row 41. Install blue airline from the outlet port of the up pressure dump valve on row 41 to the tee for that dump valve.

Step 5:T3 & T4 Route blue and black airline from row 23 to row 32. At row 32, install the black airline in the down pressure (larger) air bag & blue airline in the up pressure (smaller) air bag. Trace both airlines back to row 23 installing a tee in each airline at each row unit. Install blue airline from the up pressure air bag (smaller air bag) at each row to the tee in the up pressure (blue) circuit for that row. Install black airline from the down pressure air bag (larger air bag) at each row to the tee in the down pressure (black) circuit for that row. At row 23, cut both airlines to length and install each airline into the matching air bag.

Step 6: Install a tee in the T3 airline next to each matching dump valve on row 28. Install black airline from the outlet port of the down pressure dump valve on row 28 to the tee for that dump valve. Install a tee in the T4 airline next to the up pressure dump valve on row 27. Install blue airline from the outlet port of the up pressure dump valve on row 27 to the tee for that dump valve.

Step 7:S1 & T4 Route black airline from RD port of the 2940-103 control box to the nearest point on the main frame & install a tee. From each side of the tee, route & install black airline to the inlet port on the furthest down pressure dump valve on rows 10 & 48. (follow the same routing path as the trunk lines) Install a tee into the S1 airline next to the other down pressure dump valves on rows 18 & 39. Install black airline from tee to the inlet port of each dump valve.

Step 8:S2 Route blue airline from the RU port of the 2940-103 control box to the nearest point on the main frame & install a tee. Install a 6 inch piece of blue line into one port of tee. Install a second tee on the open end 6 inch piece of blue airline. This will give you 3 open ports on this circuit to use. Route & install blue airline from 2 of those ports to each inlet port on the up pressure dump valve on rows 13 & 41. Route & install blue airline from remaining port on the tee to the inlet port on the up pressure dump valve on row 27.

Step 9:S3 Route & install black airline from the WT port of the 2940-103 control box to the inlet of the down pressure dump valve on row 28.

2940 Operation Guide

Adjust the residue manager to move crop residue aside while moving minimal soil. Adjustments to the residue manager may have to be made when changing field conditions, soil type, or amount of residue.

ROW CLEANER DO'S AND DON'TS

1. **DO NOT** use as a tillage tool; Residue Managers are designed to move crop residue & to break up clods & crust.
2. **DO NOT** operate planter at slow speeds. Ground speed affects how aggressive the residue manager wheels are. Operate at sufficient speed (refer to you OEM planter manufacturer manual) to maintain good residue flow.
3. **DO NOT** expect 100% of crop residue to be cleared, it is not necessary and would necessitate engaging the soil. The width of path cleared depends on ground conditions, depth setting and ground speed.
4. **DO** expect to see wheels occasionally quit turning, indicating ideal (shallow) setting which is not moving soil.
5. **DO** adjust toolbar frame height 20"-22" and drawbar correctly. Very important to ensure planter opener will follow ground contours properly. See Page 70 for the planter levelness and height.
6. **DO NOT** run air pressure below 20psi or above 60psi. Full range of travel can be achieved between these settings.
7. **DO** grease the cavity of the bearings regularly. Even though the bearings are sealed, filling the hub keeps moisture, dirt, & debris from entering the hub and ruining the seal. **See pages 75-77 for greasing intervals.**
8. **DO NOT** run the coulters, if equipped, deeper than the disc opener blades. Coulters should be set to run even or slightly above disc opening blades depth.

IMPORTANT: For proper operation, the planter frame must operate level (fore, aft and side to side) and at the correct height, typically 20"-22". Regularly inspect the residue manager for loose or worn bolts. Repair and replace as needed.



Overview:

This electronic control system works with a pneumatic system that controls pressure in the air bags as well as other air valves in the system on an agricultural application. The air bags provide up and down pressure to the mechanical devices that are used on an agricultural implement.

System Layout:

There are (2) main parts to the control system. The first being a VDM (Valve Drive Module), the role of the VDM is to provide Outputs to control functions of the pneumatic system, it will also provide Inputs to monitor the pneumatic system as well as provide feedback to the operator. The second part is an in-cab switch panel/display (Cab Controller) that allows the operator to control the pneumatic system and monitor its performance.

Cab Controller Operation

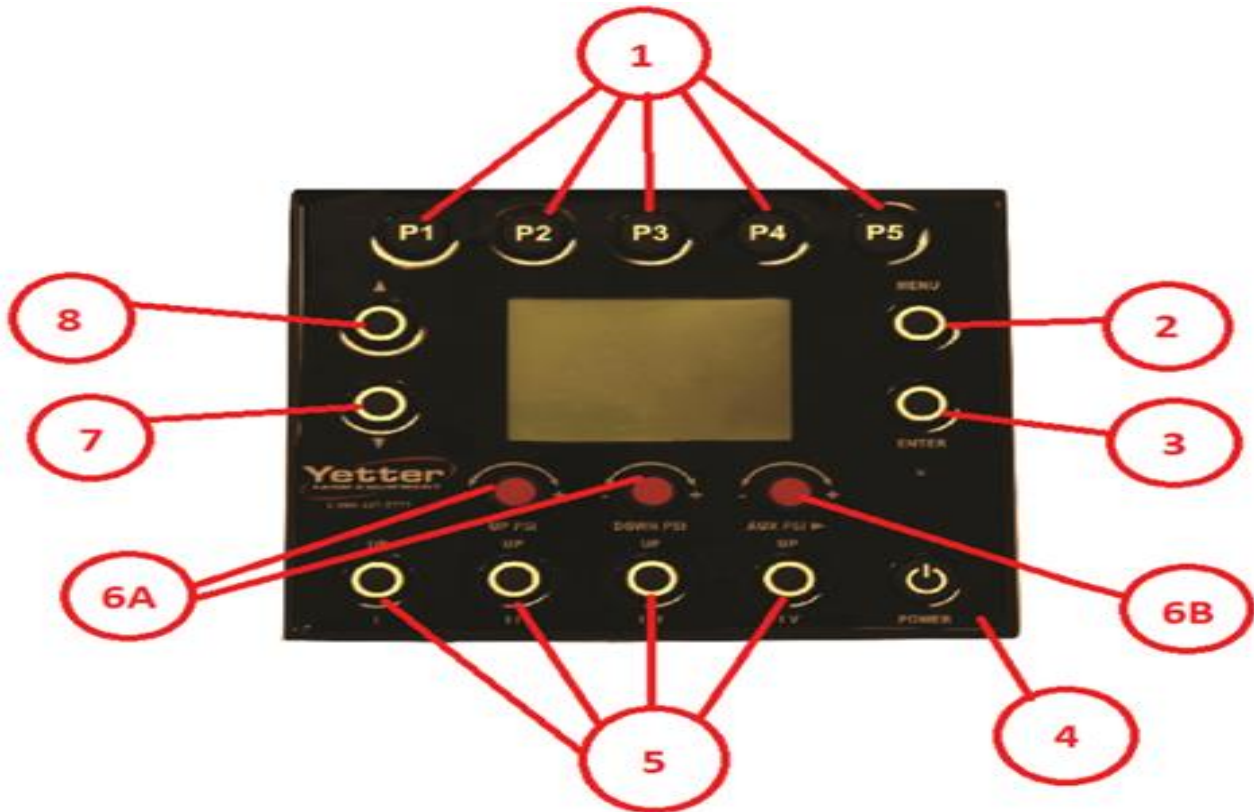

1. **PRESET 1 – 5**-Hold (approximately 5 seconds) to store the commanded pressure settings.
2. **MENU**- Press to display Menu Options. If in Menu Options, pressing Menu will take operator back one screen and eventually to operating screen.
3. **ENTER**- Press to activate/deactivate the system, also used in Menu options to make selections.
4. **POWER**- Press and hold to turn ON/OFF the 2940-100 Cab Controller Display.
5. **UP I-IV**- Press I to raise all row cleaners max travel. Pressing again lowers all row cleaners to preset setting. **Up II-IV is not used!**
6. **A PSI UP Encoder (RU)**-rotate to INCREASE/DECREASE Air Pressure on the attachment.
PSI DOWN Encoder (RD)-Rotate to INCREASE/DECREASE Air Pressure on the attachment.
6. **B PSI Aux Encoder (WT, A1, A2, A3)** - Push to scroll the cursor. ROTATE to INCREASE/DECREASE air pressure on the cursor selected circuit. (WT, A1, A2, and A3) WT circuit is the only circuit used. A1, A2, & A3 are not utilized at this time.
- ▼ 7. Push to scroll DOWN in the MENU display. Hold this down for 10 seconds to manually dump the water separator. Valve remains open for as long as button is pressed.
- ▲ 8. Push to scroll UP in the MENU display.

2940 Air Adjust Cab Controller Operation

Screen Control and Navigation:

1. **Screen Navigation:** Unless otherwise noted the menu button will always take you back one screen at a time until you are arrive at the main menu.
2. To navigate to other screens from the main menu use the scroll arrow buttons to select the page you would like to go to and then press enter to navigate there.
3. **Splash Screen (Screen 0):** This screen will be presented after the power button has been pressed. This screen will show the project number and software V/R. It will be displayed for 5 seconds. After that the system will navigate to screen 1.
4. **Main Operating Screen (Screen 1, Pictured below):** This screen is where the air system is monitored and controlled.

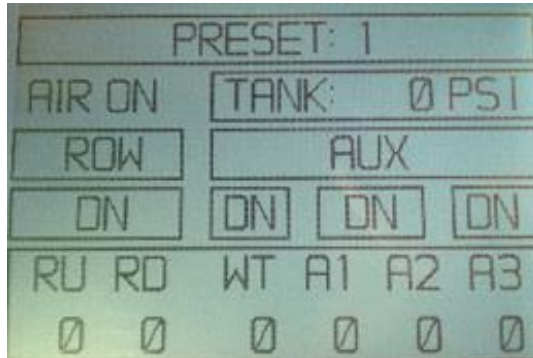

- 4.A The top of the screen shows preset you are currently using (1-5), if a manual adjustment is made it will display "PRESET (x) MANUAL" until the preset is saved, then it will display PRESET x.
- 4.B There is a field which will display "AIR ON" or "AIR OFF" depending on the status of the air system. Pressing enter will activate/deactivate the AIR ON/OFF. "AIR ON" signifies that the air system is operational and supplying air to the attachment.
- 4.C There is a field which will display the tank pressure in psi "TANK PSI".
- 4.D There are (4) fields which will indicate "UP" or "DOWN" depending on the state of the dump valves that are being controlled.
- 4.E There are (6) fields which define the tools on the system and their pressures. The pressures shown at the bottom of this screen have two modes. In normal operation mode the real pressure feedback from the air system is shown, but if a manual adjustment is made it will show the commanded value for 7.5 seconds, after that delay it will return to displaying the feedback values.

Operation Settings:

"How much Down/Lift Pressure should I be running?"

The amount of Down/Lift Pressure will vary greatly across soil types, tillage practices, soil moisture, row unit weight and many other variables. Manage the pressure in the Down and/or Lift circuits in order to maintain 90%+ Ground Contact while keeping the pressure between 20-60 psi. The cab Controller will display on the screen, the Tank pressure in psi, and the Down/Lift circuits in psi. A typical starting range for row cleaners only would be 35psi up, 30psi down, and 32psi WT. A typical starting range for row cleaner/coulter combo would be 40psi up, 35 psi down, 37psi WT. The 2940 controller allows for 5 saved settings. Press and hold preset to store setting desired. For no-till increase your down pressure settings and for conventional you will decrease your down pressure setting.

Normal operating ranges:

- Down Pressure Bags: 20-60psi
- Lift Pressure Bags: 20-60psi
- Tank Pressure: The gauge at the tank will read 145psi when full. The tank pressure reading on the 2940-100 cab controller will be around 120psi. The tank has a safety relief valve that will automatically exhaust excess pressure in the event that the pressure would exceed 150 psi.

2940 Air Adjust Cab Controller Operation

Main Menu: This screen will allow you to navigate to the setup and service screens. Selecting EXIT will return you to the main operating screen.

Setup: Currently this screen has one option to select the (Dump Valve Delay).

Dump Valve Delay: This screen allows you to adjust the dump valve delay time. Press the ENTER button to go into the edit mode, and then adjust the time with the SCROLL UP/DOWN buttons. The time value will have .25 second resolution and will be adjustable from 0-60 seconds. Pressing ENTER again will exit the edit mode. Generally, no more than 2.5 seconds is needed.

Setting the Dump Valve Delay:

- Ensure all dump valves and harnesses are plugged in securely, and dump valves are functioning properly
- Adjustments will be made in increments of .25 seconds.
- Proper action should be: when raised, row cleaners come up and stay. When lowered, dump valves will fire, row cleaners should come to ½ travel (or to when the linkage is parallel), at which time the dump valves will close, then row cleaners will fall back to preset pressures slowly.
- Access the dump valve delay screen on your cab controller.
- Adjust to .5 second delay, revert to home screen.
- Press the dump I button and observe row cleaners, it is best to have a second person looking as well.
- Adjust as needed, if they pause just above center, more time is needed. If they fall farther than center, less time is needed.
- When the correct setting is achieved, exit the dump valve delay screen and revert back to the home screen.

SEE PAGE 72 TO SEE WHAT SETTING THE DUMP VALVE DELAY SHOULD BE FOR YOUR SITUATION.

Service: This screen has (3) selections to choose from, HOUR METERS, MAINTENANCE, and FAULT STATUS.

Hour Meters: This screen will contain (2) hour meters, air compressor hours, which only increments if the compressor is on, and total system hours, which only increments if the air system is enabled (AIR ON). There will also be a field that shows duty cycle; this is a cumulative value calculated by dividing compressor hours by system hours. The percentage shown by the duty cycle should be less than 20%. **If not, perform the leak check on page 71.**

Maintenance: This screen is static and has a text description indicating basic maintenance info.

Fault Status: J1: This screen contains real time read outs of command and feedback voltage readings for each pin present in the connector labeled J1.

Fault Status: J2: This screen contains real time read outs of command and feedback voltage readings for each pin present in the connector labeled J2

Fault Status: J3: This screen contains real time read outs of command and feedback voltage readings for each pin present in the connector labeled J3

Fault Status: J4: This screen contains real time read outs of command and feedback voltage readings for each pin present in the connector labeled J4

Warning – Compressor Run Time: This screen will be displayed if the compressor has been running continuously for 15 minutes. **Evaluate the system for leaks or other issues before continuing.** When problems are fixed, press enter to clear the screen and resume normal operation.

Warning – Check Fault Screens: If a fault is detected, this screen will be displayed. Contact a service representative at Yetter, and have the fault screens ready, to review voltage readouts for diagnostics. This warning will remain displayed until the enter button is pressed.

Air System On: The state of this displayed text tells the operator if the system is operating or not. The Air System will be ON if the ENTER button is pressed on the main operating screen (screen 1). At this point the indicator will turn from red to green. It will maintain ON until ENTER is pressed again, turning the indicator back to its original color. Remember to switch the air system off, before removing power to the controller. The system is ON when the indicator is green; also the text on the screen will read “AIR ON” (vs. “AIR OFF”).

Compressor Sump Dump: This dumps any water that has built up in the compressor tank or water separator. The Compressor Sump Dump valve can also be activated by holding the “Scroll Down” button while on the Main Operating Screen for 10 seconds. The valve will remain open as long as the button is pressed, releasing the button will close the valve.

2940 Air Adjust Cab Controller Operation

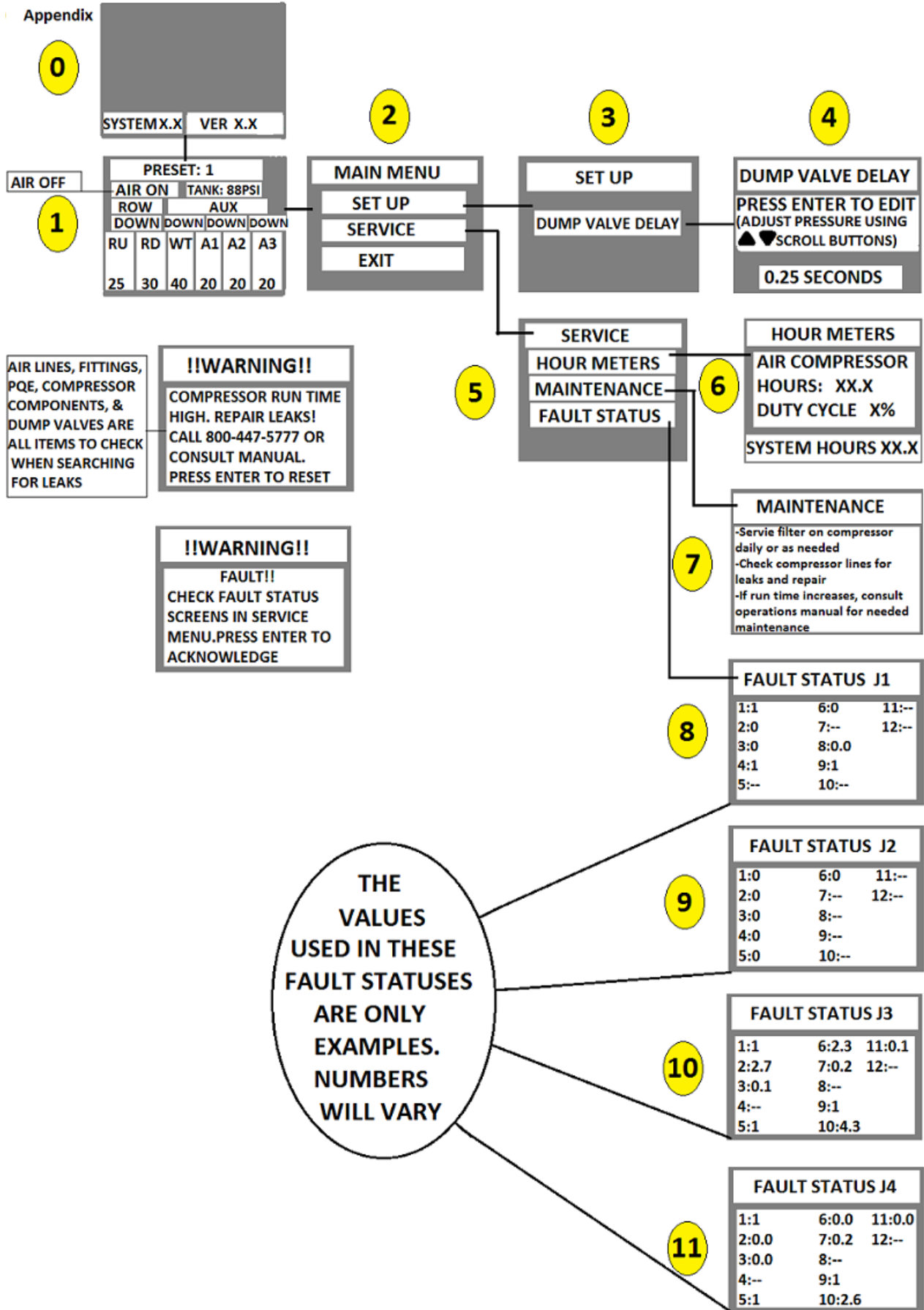

OPERATION PRECAUTIONS



Read this before field operation of the Yetter product.

-MACHINE OPERATION

IMPORTANT: Failure to properly set the planter frame height and levelness can result in less than successful operation of the planter and the Yetter product and may result in damaged equipment. All operators should read and thoroughly understand the instructions given prior to using the Yetter product.

NOTE: **DO NOT** use this product if the planter is not adjusted properly!

Leveling the planter: Lower the planter frame to operation height (**Usually 20"-22"**). Read the planter operator's manual for recommended setting. Check to be sure the toolbar and row unit parallel arms are level fore and aft. Re-Check when the planter is in the field and has been fully loaded with seed, fertilizer, etc. Also, a field check with a bubble level on the frame should be made of the hitch height to ensure level operation front to back.

It is important for the planter to operate level laterally. Tire pressure must be maintained at pressures specified by the manufacturer.

Field and actual planting conditions change and will dictate planter frame heights. You must ensure that the row unit parallel arms are approximately parallel with the ground.

IMPORTANT: For proper operation of the planter attachments and row units, it is imperative that the planter toolbars and row unit parallel arms be level side-to-side and front-to-rear. The toolbar frame should operate at a 20"-22" height from the planting surface. Check the manufacturer's operator's manual for instructions on how to adjust the frame height and levelness.

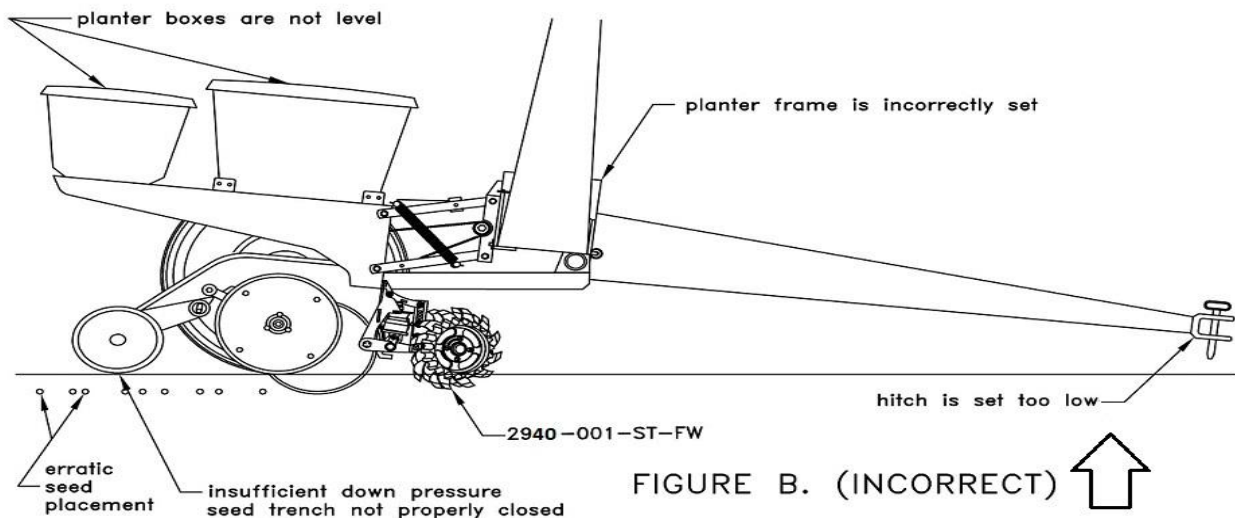
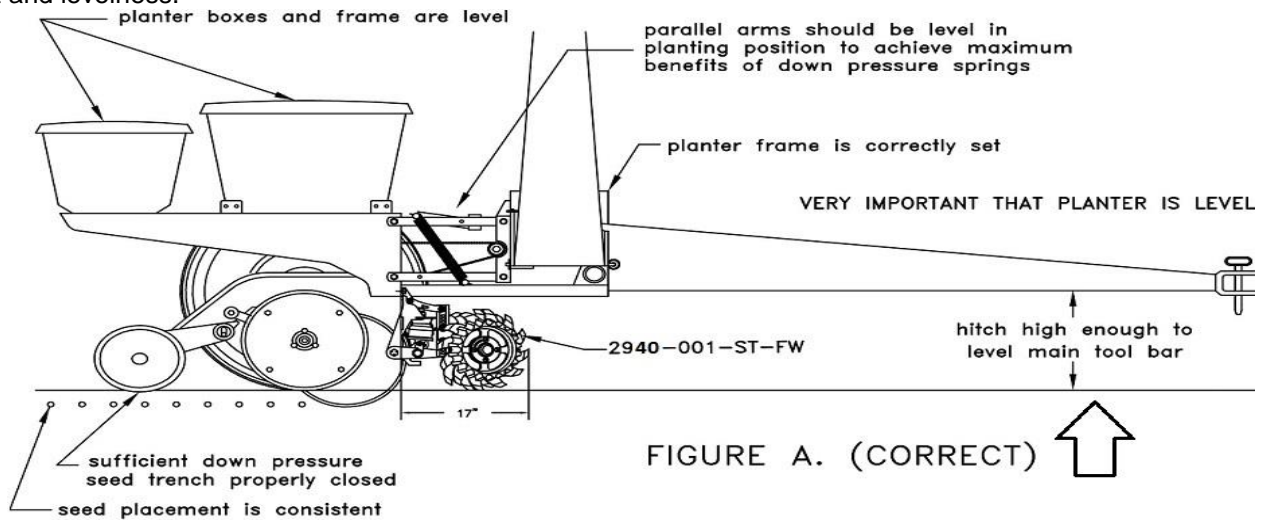

OPERATION PRECAUTIONS

To ensure the hydraulic compressor motor doesn't exceed the recommended operating RPM level, the hydraulic oil flow control valve has been preset. In some instances, the compressor may run below optimum rpm, or will not reach 145psi of tank pressure read at the gauge on the compressor unit. If this is the case, an adjustment to the flow control valve will need made. Only open flow control valve enough to allow the compressor to build to 145psi tank pressure read at the gauge on the compressor unit. Opening the flow control too far could cause overspeeding and reduced service life of the compressor. Follow the instructions below to make the proper adjustment.

NOTE: Before making any adjustments to the flow control valve, adjust the tractor hydraulic flow higher if possible. The hydraulic motor speed on the hydraulic compressor should not exceed 1350rpm. Rpm's on the hydraulic compressor may be checked via the fan blades with an optical tachometer.

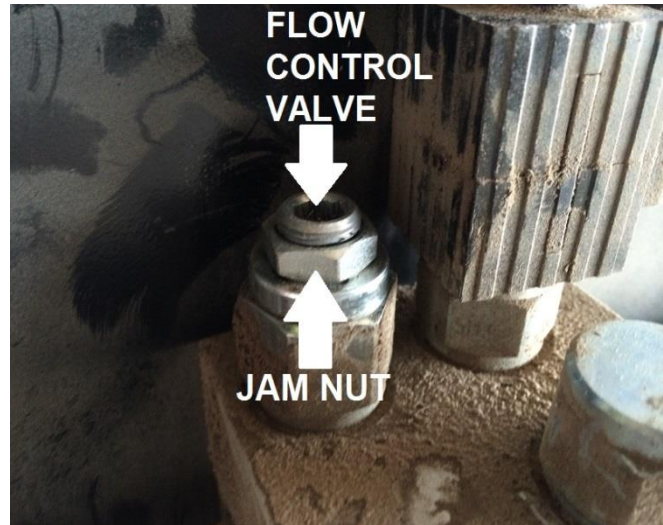
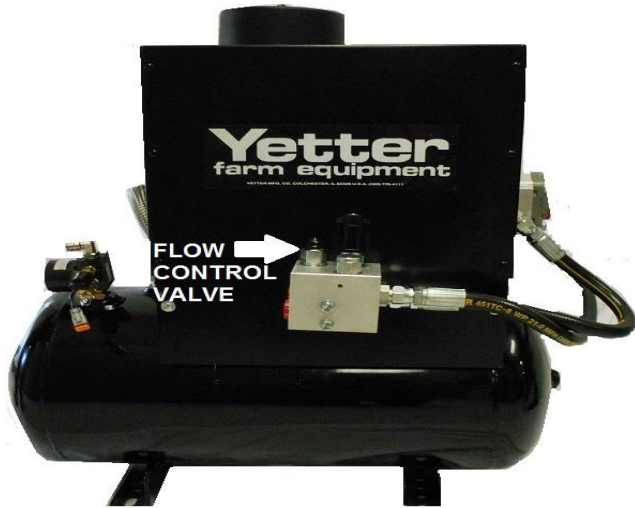

- STEP 1:** Remove the black seal from hydraulic flow control valve and jam nut.
- STEP 2:** Turn the 2940 system on by pressing ENTER on the cab controller (Air On displayed) & supply hydraulic pressure to compressor. Make adjustments while hydraulic motor is running. Open tank drain to allow continuous running if necessary.
- STEP 3:** Insert 5/16 Allen wrench into flow control valve.
- STEP 4:** Using an 11/16 wrench, loosen jam nut by turning counterclockwise.
- STEP 5:** Using a 5/16 Allen wrench, **SLIGHTLY** turn the flow control valve counterclockwise (the equivalent to 3 degrees or 1/32 of a turn) to increase the hydraulic motor speed. Each time an adjustment is made, allow the compressor to build to its potential 145psi shut off mark. If 145psi is not achieved, drain tank pressure until compressor turns on, and make another adjustment. Repeat these steps until 145psi is achieved without compressor struggle. **DO NOT RUN MOTOR ON COMPRESSOR MORE THAN 1350RPM!**
- STEP 6:** Once the flow control valve is set properly, hold the Allen wrench in place and tighten the jam nut.

Pre-Field Operation Guide

LEAK TESTING:

A leak testing procedure should be performed after set-up of the 2940 Air Adjust system is complete. This procedure shall be performed at the beginning of each planting season and every 20 hours of in season use. **In addition, it should be performed if the user notices a lack of air pressure availability or if the compressor is running an abnormally high duty cycle or run time.** It will help keep the duty cycle in check, thus extending the life of the compressor.

- Step 1:** Power the cab controller, turn all pressures (RU, RD, and WT) to 0psi, and press ENTER to activate the system. Make sure the compressor supplying air to the system has run, built 145psi of tank pressure, and shut off.
- Step 2:** Check the compressor, water separator assembly, and all compressor housing components for leaks.
- Step 3:** Turn up pressure (RU) to 30psi, exit the tractor cab, and start at the compressor housing checking all blue line on the RU circuit for leaks. Check all fittings, tees, and dump valves on the RU circuit. Repair leaks as needed & then turn up pressure back to 0psi
- Step 4:** Turn down pressure (RD) and wheel track (WT) pressure to 30psi, exit the tractor cab, and start at the compressor housing checking all black airlines on the RD & WT circuit for leaks. Check all fittings, tees, and dump valves on the RD & WT circuit. Repair leaks as need.
- Step 5:** With tank pressure reading 145psi on the gauge at the compressor, compressor not running, and 0psi commanded in all circuits, note the tank psi. Start a stop watch & after 5 minutes, note the tank pressure. If tank pressure drops more the 2psi, check for leaks around/inside the compressor housing. Repair as needed.
- Step 6:** With tank pressure reading 145psi on the gauge at the compressor, compressor not running, and 30 psi commanded in all circuits, note the tank psi. Start a stop watch & after 5 minutes, note the tank pressure on the gauge at the tank. If tank pressure drops more the 2psi, check for leaks on the row cleaner fittings, tees, and dump valves. Repair as needed.

Pre-Field Operation Guide Con't

AIR COMPRESSOR PRE-OPERATING TEST PROCEDURE:

Before beginning this test, run the compressor system leak test and ensure it passes. There should be virtually no leaks in the tank circuit before performing this test.

Step 1: Start tractor if not already running. Test results will be skewed if compressor supply voltage is inadequate (13.8 VDC no-load recommended).

Step 2: Start a stopwatch when the Tank pressure reaches the 125psi pressure valve and the compressor starts running

Step 3: Note the time to recover back to 145psi in the tank & the compressor shuts off. If the time recorded is greater than 15 seconds, the compressor or system is either leaking or the compressor is considerably worn. Consider servicing or replacing the compressor before using. If no action is taken and the compressor continues to be used, closely monitor the 2940 Air Adjust system pressure availability.

Proper Settings

Dump Valve Delay

To set the dump valve delay, start at the operating screen, press **Menu**, select **Set Up**, press **Enter** to edit, & use the following guide to set to your planter size:

Non Split Row Planters

- 6-12 row planters - .5 seconds
- 16-24 row planters - .75-1.5 seconds
- 32-36 row planters - 1.75 – 2 seconds
- 48-54 row planters - 2.25-2.5 seconds

Split Row Planters

- 6/11, 6/12, 8/15, or 8/16 planters - .5 - .75 seconds using only corn rows, .75 - 1.5 seconds when using all rows
- 12/23 or 12/24 planters - .5 - .75 seconds using only corn rows, 1.75 – 2 seconds when using all rows
- 16/31 or 16/32 planters - .75 – 1 seconds using only corn rows, 2 - 2.25 seconds when using all rows

Air Pressure Settings

Residue Managers Only

A common question is “What pressures should I start out at?” A good starting pressure setting would be 35psi Up Pressure, 30psi Down Pressure, & 32psi Wheel Track(WT). This particular setting will give each row cleaner a nice sturdy float. If this pressure setting doesn't remove enough residue or trenches/digs furrows, adjust the settings accordingly until the row cleaner is doing exactly what you want it to do. If the row cleaner is trenching, lessen the down pressure or increase the up pressure. If not enough residue is removed, lessen the up pressure or increase the down pressure. Once a setting is found, hold the desired preset button (P1-P5) until saved. Each field may require a different setting even though field conditions seem the same. For example, if you use a setting for one no-till field planting corn in soybean residue, you may find that the setting used for the next field planting corn in soybean residue in no-till conditions may be different. The reason may be the amount of residue, soil types, moisture amounts, etc.

Residue managers/Coulter Combos

A common question is “What pressures should I start out at?” A good starting pressure setting would be 40psi Up Pressure, 35psi Down Pressure, & 37psi Wheel Track (WT). This particular setting will give each row cleaner a nice sturdy float. If this pressure setting doesn't remove enough residue or trenches/digs furrows, adjust the settings accordingly until the row cleaner is doing exactly what you want it to do. If the row cleaner is trenching, lessen the down pressure or increase the up pressure. If not enough residue is removed, lessen the up pressure or increase the down pressure. Once a setting is found, hold the desired preset button (P1-P5) until saved. Each field may require a different setting even though field conditions seem the same. For example, if you use a setting for one no-till field planting corn in soybean residue, you may find that the setting used for the next field planting corn in soybean residue in no-till conditions may be different. The reason may be the amount of residue, soil types, moisture amounts, etc.

Yetter Hydraulic Compressor Maintenance

CLEANING OR REPLACING THE 2940-106 AIR FILTER



Filter cleanliness is critical to maintain the performance and service life of the compressor. Recommendations for cleaning are daily and replace every 200 hours OR at beginning of every planting season.

STEP 1: REMOVE WING NUT AND FILTER COVER

STEP 2: REMOVE FILTER (IF CLEANING, TAP FILTER ON SOLID SURFACE TO REMOVE DIRT FROM PLEATS AND CLEAN FILTER BASE) DO NOT USE COMPRESSED AIR TO CLEAN FILTER!

STEP 3: INSTALL NEW OR CLEANED FILTER

STEP 4: INSTALL WING NUT AND FILTER COVER REMOVED IN STEP 1

Check Hydraulic Air Compressor Oil

⚠ Deactivate SCV operating hydraulic compressor and turn tractor off before servicing

NOTE: Check hydraulic air compressor oil daily before use during planting season and beginning of each season.

Sight glass is positioned behind the housing for protection purposes but easily seen without removing the housing. Oil level should be visible in sight glass. If oil needs added, remove housing and add grade 111 synthetic or PAO synthetic compressor oil until seen in middle of sight glass



Filling or Changing Hydraulic Air Compressor Oil

⚠ Deactivate SCV operating hydraulic compressor and turn off tractor before servicing

Filling Hydraulic Air Compressor Oil

Step 1: Remove cap

Step 2: Using a proper sized funnel add grade 111 synthetic or a PAO synthetic compressor oil until oil level is in middle of the sight glass

Step 3: Install cap

Changing Hydraulic Air Compressor Oil

Step 1: Remove cap for ventilation while draining

Step 2: Place container in position to catch oil while draining

Step 3: Remove drain plug to allow oil to drain

Step 4: Install removed drain plug after oil drained in entirety

Step 5: Add grade 111 synthetic or a PAO synthetic compressor oil until oil level is in middle of the sight glass

Step 6: Install cap

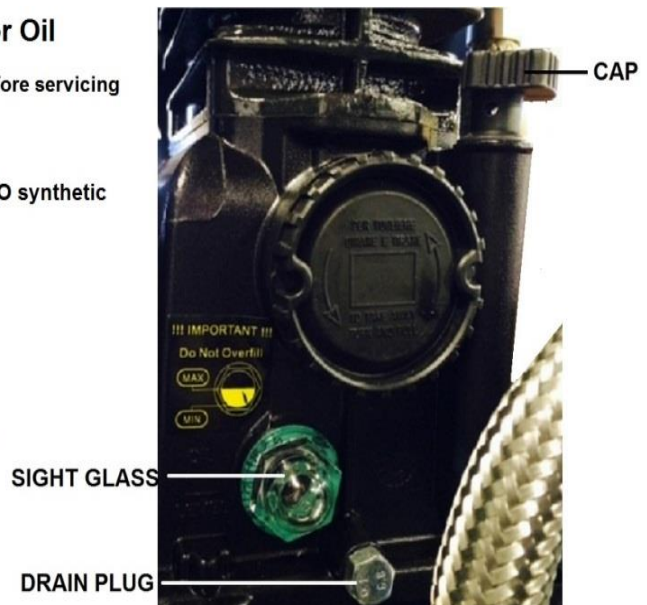

Yetter Hydraulic Compressor Maintenance

WARNING:

Keep extremities out of the compressor housing when compressor is running, has potential to run, or recently shut off as there are rotating and high temperature parts that may cause injury. Always turn tractor off and disconnect power before performing any maintenance.



LUBRICATION:

The compressor is shipped empty of pump lubrication and needs oil added before operation. Provided is a 1 Liter bottle of grade 111 synthetic. Add oil until oil level is seen half way up on the sight glass. Yetter part number for purchasing new bottle is 2940-550.

GUARDS:

Always ensure the housing and guards are in place during operation.

AIR FILTER CARTRIDGE:

Yetter part number 2940-549. Order as needed.

MAINTENANCE SCHEDULE GUIDE

DAILY

Check oil level and fill as needed
Check air filter cleanliness and clean/replace as needed
Check hoses for fluid leaks and replace/fix as needed
Check air lines for air leaks and replace/fix as needed
Drain tank pressure with Tank Drain Valve (labeled N on page 12) to allow moisture to drain

SEASONALLY/200 COMPRESSOR HOURS

Change compressor oil
Change inlet air filter
Check fluid hoses and air lines for weakness or weathering and replace as needed.
Check hydraulic fittings for proper connections with no leaks, replace as needed.



**FIRST OIL CHANGE SHOULD TAKE PLACE AFTER
APPROXIMATELY 50 RUNNING HOURS**

Maintenance/Assembly

Bearing Assembly and Maintenance

Practice Safety

Understand and practice safe service procedures before doing work. Follow ALL the operating, maintenance and safety information in the equipment operator manual. Clear the area of bystanders, especially small children, when performing any maintenance or adjustments. Keep work area clean and dry. Use adequate lighting for the job. Use only tools, jacks and hoists of sufficient capacity for the job. Never lubricate, service, or adjust machine while it is moving. Keep hands, feet, and clothing from power-driven moving and rotating parts. Disengage all power and operating controls to relieve pressure. Lower equipment to the ground and stop the engine. Remove the key. Wait for all moving parts to stop before servicing, adjusting, repairing or unplugging. Securely support any machine elements with blocks or safety stands that must be raised for service work. Keep all parts in good condition and properly installed. Fix damaged equipment immediately. Replace worn or broken parts. Remove any buildup of grease, oil, or debris. Make sure all guards are in place and properly secured when maintenance work is completed.



CAUTION: To help prevent serious injury or death to you or others caused by unexpected movement, service machine on a level surface. Lower machine to ground or sufficiently lock or block raised machine before servicing. If machine is connected to tractor, engage parking brake and place transmission in "PARK", shut off engine and remove key. If machine is detached from tractor, block wheels and use shop stands to prevent movement.



CAUTION: Use grease based on NLGI consistency numbers and the expected air temperature range during the service interval. Use a multi-purpose lithium, water resistant, moderate speed, and NLGI grade #2 grease. Other greases may be used if they meet the following NLGI Performance Classification: GC-LB

IMPORTANT: Some types of grease thickener are not compatible with others. Consult your grease supplier before mixing different types of grease.

Alternative Lubricants

Conditions in certain geographical areas may require special lubricants and lubrication practices which do not appear in the operator's manual. If there are any questions, consult Yetter Manufacturing Co. to obtain latest information and recommendation.

PART #	DESCRIPTION	<i>OUNCES OF GREASE</i>
2967-404	13" TAPER TOOTH R.M. WHEEL	1.12 OZ
2967-602	13" SHARK TOOTH R.M. WHEEL	1.12 OZ
2967-186	FLOATER WHEEL KIT W/R.M. WHEEL	2.08 OZ
2967-596	HEAVY DUTY OR BEVEL R.M. WHEEL W/ FLOATER WHEEL KIT	2.40 OZ

Storing Lubricants

Your machine can operate at top efficiency only if clean lubricants are used.

Use clean containers to handle all lubricants.

Store them in an area protected from dust, moisture and other contaminants.

Maintenance

Bearing Replacement Installation

1. When assembling the wheels, bearing assembly and hubcap, be sure to align the grease transfer hole in the spoke wheel with the groove in the hubcap and hole in the hub to allow grease passage.
2. Assemble the wheels, hubs and caps.
3. Grease the wheel/hub/bearing assembly

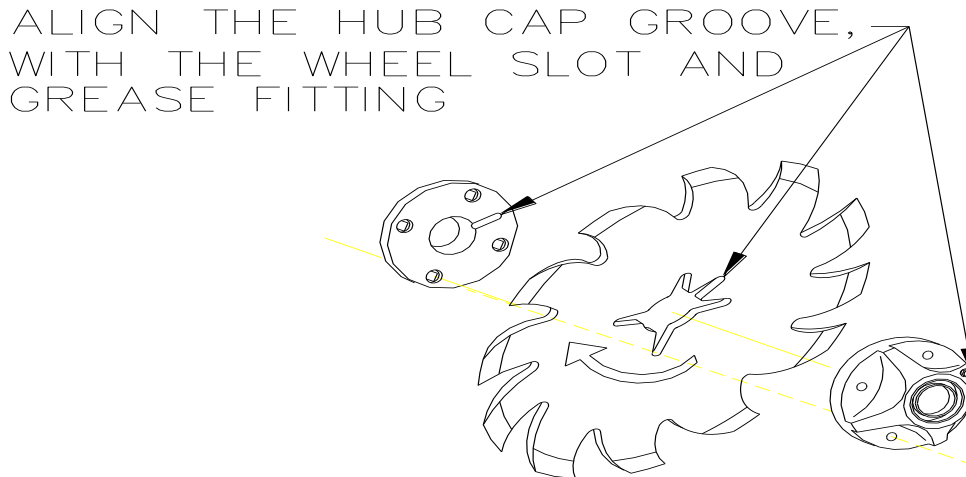
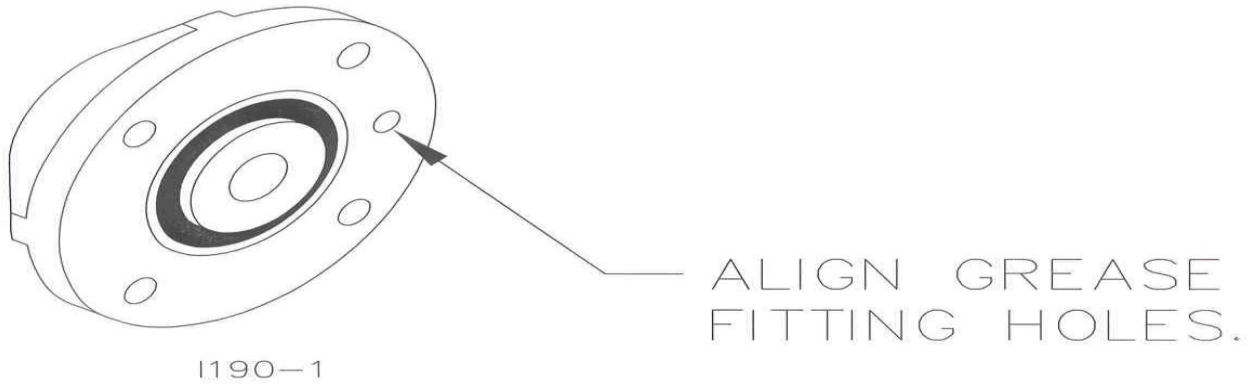

NOTE: Be certain to align the grease fitting with the slot in the wheel and the hubcap so that the grease can flow freely to the cavity. The bearing is sealed but the cavity must be filled so that dirt, moisture, and debris do not enter the cavity and ruin the seal.

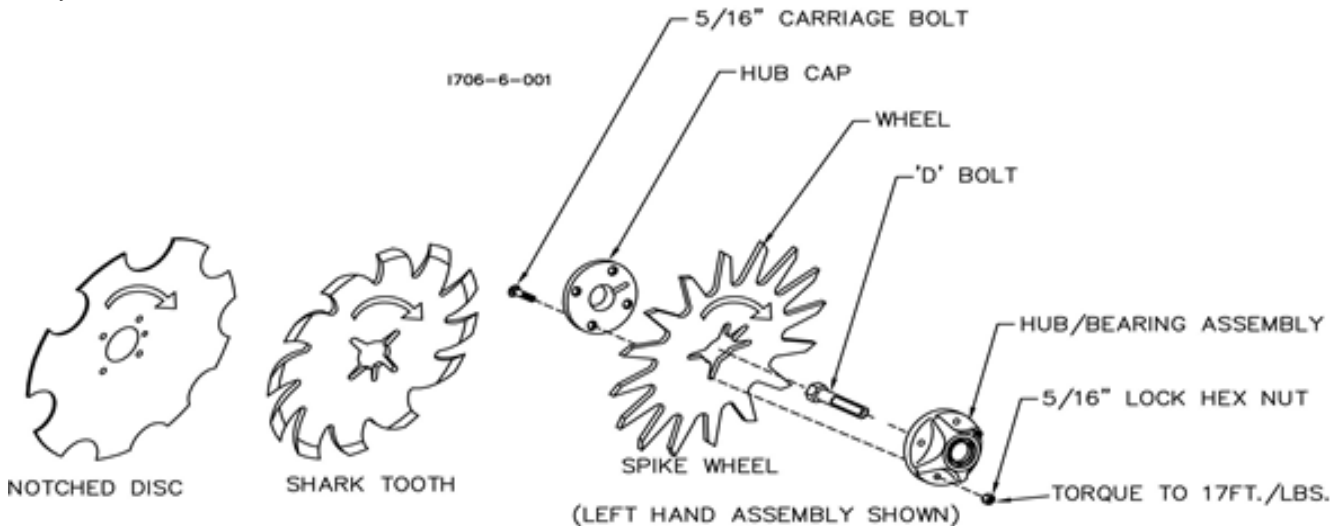

Maintenance

Lubrication Symbols



Lubricate with grease at hourly interval indicated on symbol.

Lubrication Intervals

Residue Manager



Grease Zerk on the Hub

Residue Manager/Coulter Combo

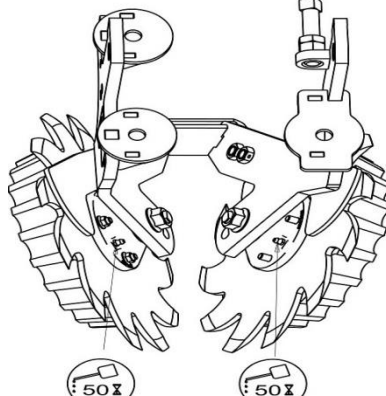

Grease Zerk on Hub

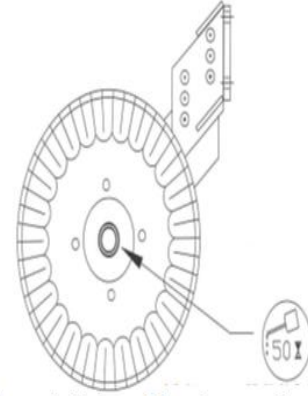

Repack Hub and bearings each season

IMPORTANT: The recommended service intervals are based on normal conditions; severe or unusual conditions may require more frequent lubrication.

- Perform each lubrication and service procedure at the beginning and end of each season.
- Clean grease fittings before using grease gun, to avoid injecting dirt and grit into the bearing.
- Replace any lost or broken fittings immediately. If a fitting fails to take grease, remove and clean thoroughly, replace fitting if necessary. Also check for failure of adjoining parts.

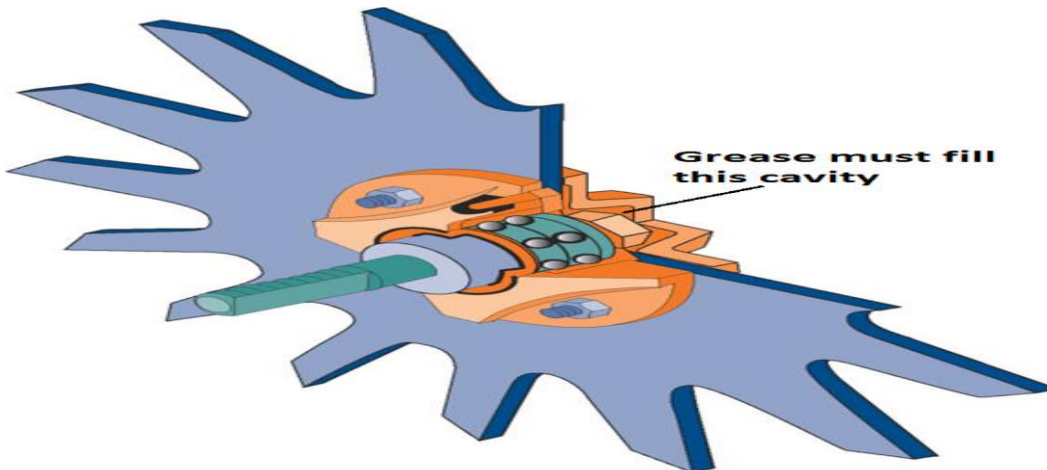

Storing the Equipment

- Store the machine in an area away from human activity in the **RAISED** position.
- Install service locks on all wheel cylinders.
- At the end of the season, the machine should be thoroughly inspected and prepared for storage. Repair or replace any worn or damaged components to prevent down time at the start of the next season. Store the machine under cover with all parts in operating condition.
 - Clean machine thoroughly removing all dirt, debris, and crop residue which holds moisture causing rust.
 - Inspect machine for worn or broken parts. See your Yetter Farm Equipment dealer during the off-season so that parts or service can be acquired when machine is not needed in the field.
 - Lubricate bearings as outlined in the Lubrication section.
 - Paint all parts which are chipped or worn and require repainting.
 - Store machine in a clean, dry place with the planting unit out of the sun.
 - If the machine cannot be stored inside, cover with a waterproof tarpaulin and tie securely in place.
 - Do not allow children to play on or around the machine.

AIR BAG REPLACEMENT

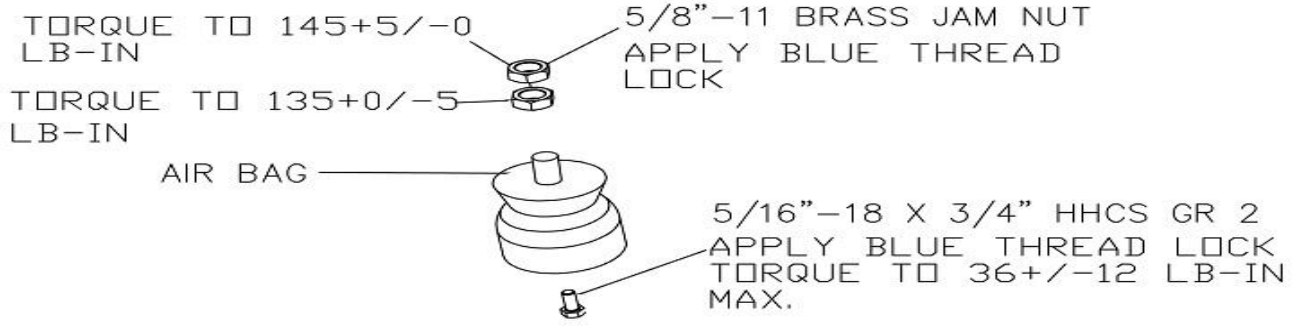

AIR BAG REPLACEMENT

2940-306
2940-308

6" AIR BAG FOR UP PRESSURE
8" AIR BAG FOR DOWN PRESSURE

PARTS IDENTIFICATION

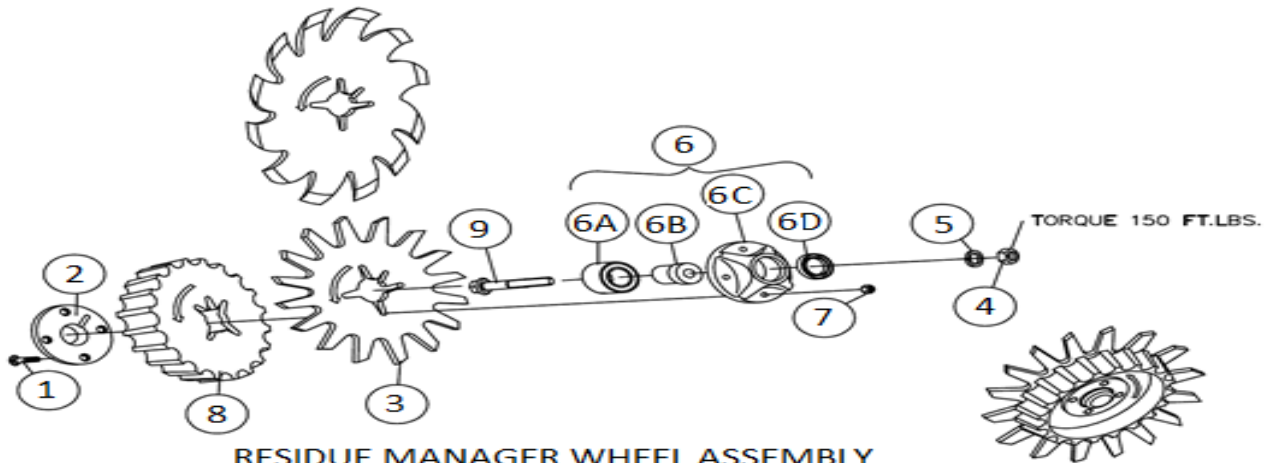

RESIDUE MANAGER WHEEL ASSEMBLY
(1 WHEEL ASSEMBLY)

DET	QTY	PART NO.	DESCRIPTION
1	4	2505-207	5/16-18 X 1 1/4 CAR BLT GR5
	4	2505-208	5/16-18 X 1 1/2 CAR BLT GR5 (FOR USE WITH HEAVY DUT WHEELS)
	4	2505-209	5/16-18 X 1 3/4 CAR BLT GR5 (FOR USE WITH FLOATER WHEEL)
2	1	2965-352	HUB CAP CASTING, 4 BOLT, BLACK
3	1	2967-404	13" TAPER TOOTH SPOKE WHEEL
	1	2967-596	3/8 TAPER TOOTH SPOKE WHEEL
	1	2967-602	13" SHARK TOOTH WHEEL
	1	6200-350	13" BEVELED WHEEL, LH
	1	6200-351	13" BEVELED WHEEL, RH
4	1	2520-452	5/8-11 HEX NUT
5	1	2525-451	5/8 LOCKWASHER
6	1	2965-128	HUB AND BEARING ASSEMBLY, 4 BOLT
6A	1	2570-594	BEARING, 2 ROW NTN# DF0654L
6B	1	2570-715	BEARING INSERT, TRASHMASTER
6C	1	2965-351	HUB CAST, MACHINED, 4 BOLT
	1	2533-110	1/4" SELF TAP ZERK (NOT SHOWN)
6D	1	2550-052	SEAL, CR# 13548
7	4	N10213	5/16-18 HEX FLANGE SERRATED NUT
8	1	2967-555	FLOATER WHEEL
9	1	2570-740	D-BOLT, FLGD, 5/8-11 X 2.812" GR 8

PARTS IDENTIFICATION

2940-049

Air Adjust Mount Extension Kit

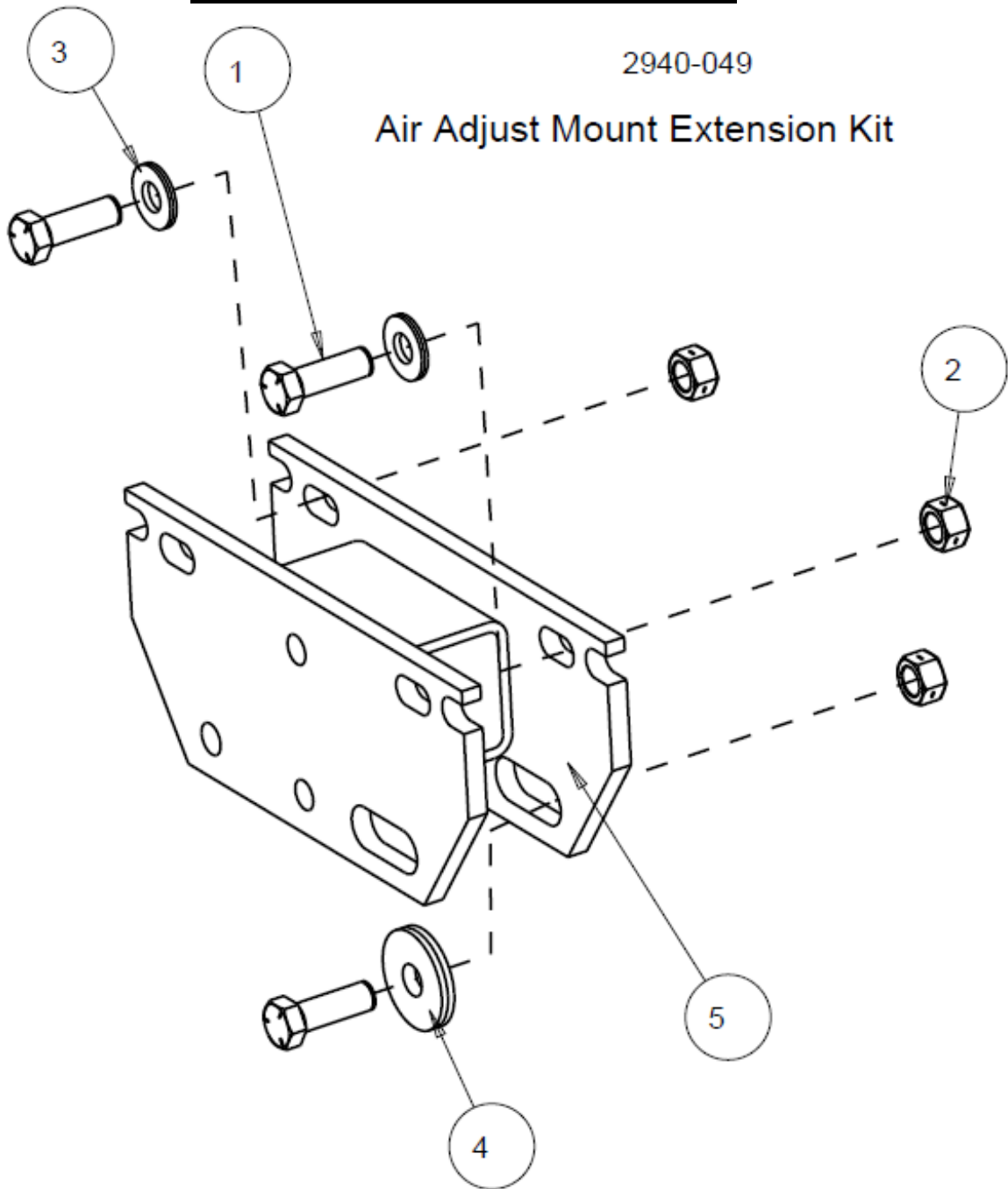

ITEM	PART #	DESCRIPTION	QTY
1	2502-294	1/2-13 X 1-1/2 HHCS GR5 YD	3
2	2520-357	1/2-13 LOCK HEX NUT ZP	3
3	2526-355	1/2 FLAT WASHER HARD'ND ZYD	2
4	2526-402	9/16ID X 1-3/4 OD X 1/4MBZP	1
5	2940-220	MOUNT EXTENSION W.A.	1

PARTS IDENTIFICATION

2940-190

NOTE: UPPER NUT MUST MAINTAIN 10 LB-IN GREATER TORQUE THAN LOWER NUT.

TORQUE TO 145 IN-LB +5/-0

TORQUE TO 135 IN-LB +0/-5

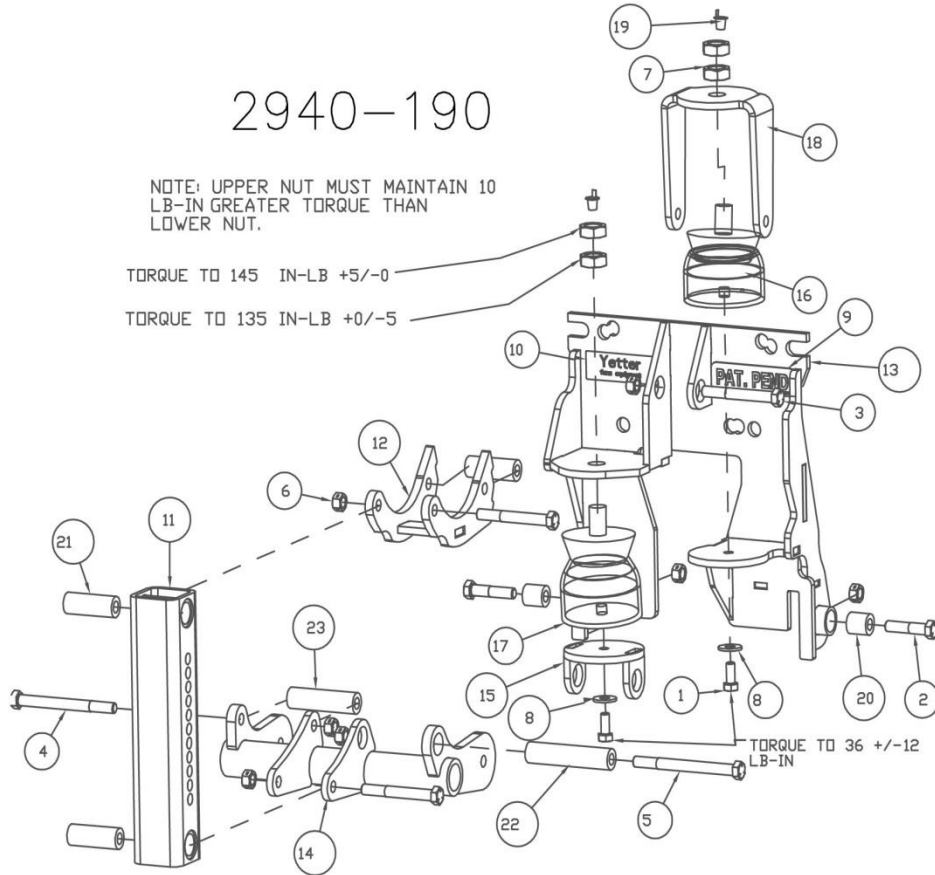

ITEM	PART NO.	DESCRIPTION	QTY
1	2502-200	5/16-18 X 3/4 HHCS W/THD LCK GR 2 ZP	2
2	2502-245	3/8-16 X 1-3/4 HHCS GR 5 ZP	2
3	2502-246	3/8-16 X 3 HHCS GR5 ZP	3
4	2502-254	3/8-16 X 4 HHCS GR 5 ZP	1
5	2502-260	3/8-16 x 4-1/2 HHCS GR 5 ZP.	1
6	2520-255	3/8-16 LOCK HEX NUT ZP	7
7	2520-454	5/8-11 BRASS JAM NUT	4
8	2526-201	5/16STANDARD FLATWASHER ZP	2
9	2565-071	PATENT PENDING DECAL	1
10	2565-179	YETTER DECAL, 1 X 3	1
11	2940-210	ADJUSTMENT TUBE W.A.	1
12	2940-211	UPPER LINK W.A.	1
13	2940-212	UNIVERSAL MOUNT PLATE W.A.	1
14	2940-213	LOWER PARALLEL ARM W.A.	1
15	2940-214	AIR BAG BRACKET W.A.	1
16	2940-306	FPE SK-37-6 INCH AIR BAG	1
17	2940-308	FPE SK-37-8 INCH AIR BAG	1
18	2940-309	UPFORCE TOP MOUNT	1
19	2940-340	CAP PLUG - 171201HB L-2 PE-LD01R	2
20	2940-472	.750" DD X .406" ID X .810" BUSHING	2
21	2940-473	.750" DD X .406" ID X 2" BUSHING	3
22	2940-474	.750"DD X .406" ID X 3.437" BUSHING	1
23	2940-475	.750" DD X .406" ID .X 2.756" BUSHING	1

MANUFACTURED 10/2013 - PRESENT

PARTS IDENTIFICATION

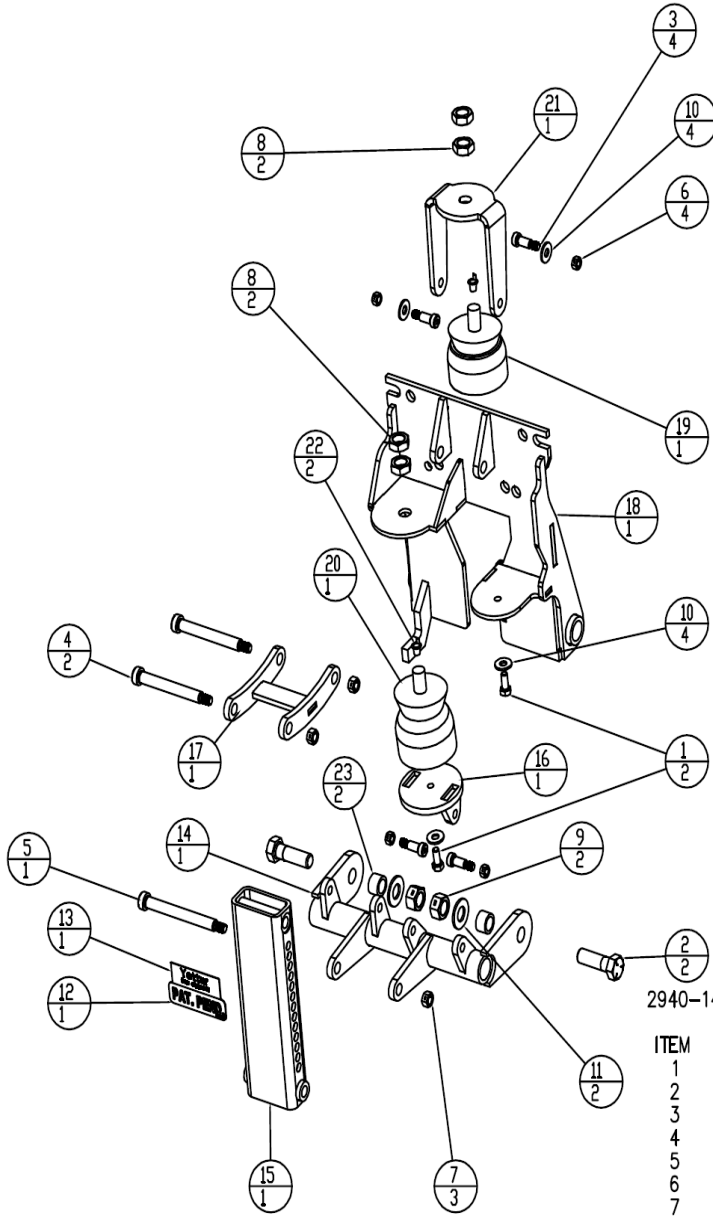

1818-8

2940-140 RESIDUE MANAGER AIR BAG/MOUNT BRACKET ASSEMBLY

ITEM	QTY	PART NO.	DESCRIPTION
1	2	2502-200	5/16-18 X 3/4 HHCS GR 2 ZP
2	2	2502-391	5/8-11 X 2 HHCS GR 5 ZP
3	4	2510-310	3/8 X 3/4 SHOULDER BOLT ALLOY
4	2	2510-320	1/2 X 3-3/4 SHOULDER BOLT ALLOY
5	1	2510-321	1/2 X 4-1/4 SHOULDER BOLT ALLOY
6	4	2520-205	5/16-18 LOCK HEX NUT ZP
7	3	2520-255	3/8-16 LOCK HEX NUT ZP
8	4	2520-454	5/8-11 BRASS JAM NUT
9	2	2520-459	5/8-11 LOCK HEX NUT ZP
10	4	2526-201	5/16 STANDARD FLATWASHER ZP
11	2	2526-453	5/8 SAE FLATWASHER ZP
12	1	2565-071	PATENT PENDING DECAL
13	1	2565-179	YETTER DECAL, 1 X 3
14	1	2940-202	SHORT LOWER RACK W.A.
15	1	2940-203	STEM TUE W.A.
16	1	2940-204	AIR BAG LOWER W.A.
17	1	2940-205	UPPER LINK W.A.
18	1	2940-206	UNIVERSAL MOUNT PLATE W.A.
19	1	2940-306	FPE SK-37-6" SMALLER AIR BAG
20	1	2940-308	FPE SK-37-8 INCH LARGER AIR BAG
21	1	2940-309	UPFORCE TOP MOUNT
22	2	2940-340	CAP PLUG - 171201HB L-2 PE-LD01R
23	2	6000-335	9/16" BUSHING

MANUFACTURED 02/2013 - 09/2013

PARTS IDENTIFICATION

2940-001-ST-FW

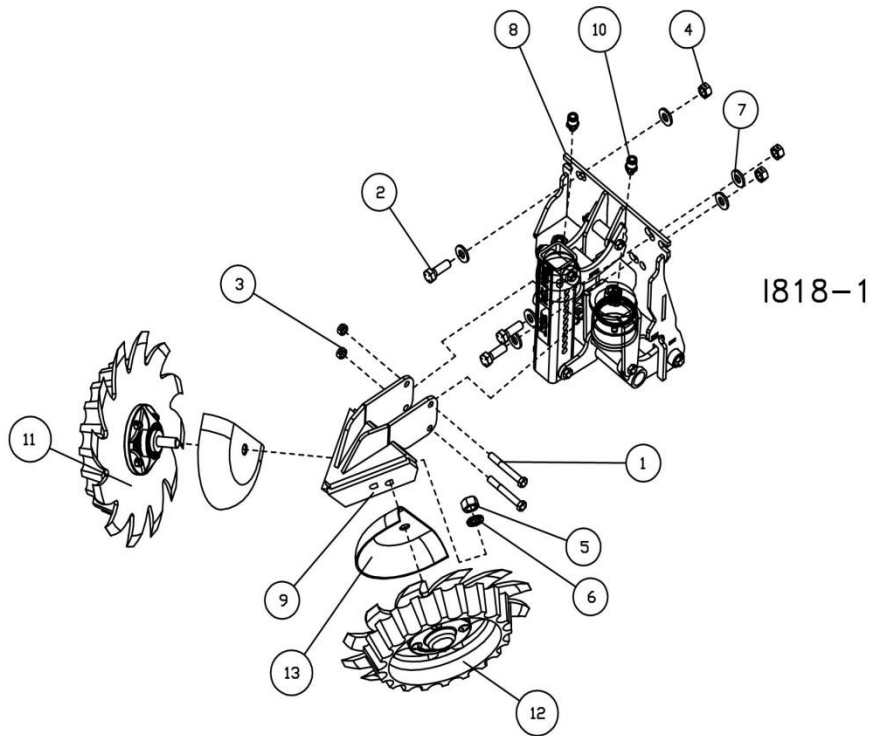

ITEM	QTY	PART NO.	DESCRIPTION
1	2	2502-246	3/8-16 X 3 HHCS GR5 ZP
2	3	2502-294	1/2-13 X 1-1/2 HHCS GR5 YD
3	2	2520-255	3/8-16 LOCK HEX NUT ZP
4	3	2520-357	1/2-13 LOCK HEX NUT ZP
5	2	2520-452	5/8-11 HEXNUT ZP
6	2	2525-451	5/8 MED LOCKWASHER ZP
7	6	2526-355	1/2 FLAT WASHER HARD'ND ZYD
8	1	2940-190	PNEUMATIC R.M. MOUNT ASSEMBLY
9	1	2940-215	AIR ADJUST WIDE STEM W.A.
10	2	2940-339	3/8 PUSH CONNECT STRAIGHT 1/8 NPT MALE THREAD
11	1	2966-140	SPOKE WHEEL ASSY, RH, 3' D-BOLT
		2966-140-BW	BEVEL WHEEL ASSY, RH, 3' D-BOLT
		2966-140-BW-FW	BEVEL WHEEL ASSY, RH, 3' D-BOLT FLT WHL
		2966-140-FW	SPOKE WHEEL ASSY, RH, 3' D-BOLT FLT WHL
		2966-140-HD	HD SPOKE WHEEL ASSY, RH, 3' D-BOLT
		2966-140-HD-FW	HD FW SPOKE WHEEL ASSY, RH, 3' D-BOLT
		2966-140-ST	SHARKTOOTH ASSY, RH, 3' D-BOLT
		2966-140-ST-FW	SHRKT ASSY,RH,3'D-BOLT FLT WL
12	1	2966-141	SPOKE WHEEL ASSY, LH, 3' D-BOLT
		2966-141-BW	BEVEL WHEEL ASSY, LH, 3' D-BOLT
		2966-141-BW-FW	BEVEL WHEEL ASSY, LH, 3' D-BOLT FLT WHL
		2966-141-FW	SPOKE WHEEL ASSY, LH, 3' D-BOLT FLT WHL
		2966-141-HD	HD SPOKE WHEEL ASSY, LH, 3' D-BOLT
		2966-141-HD-FW	HD FW SPOKE WHEEL ASSY, LH, 3' D-BOLT
		2966-141-ST	SHARKTOOTH ASSY, LH, 3' D-BOLT
		2966-141-ST-FW	SHRKT ASSY,LH,3'D-BOLT FLT WL
13	2	2967-392	SHIELD, RM COMBO-PAINTED

MANUFACTURED 10/2013 - PRESENT

PARTS IDENTIFICATION

2940-001-ST-FW

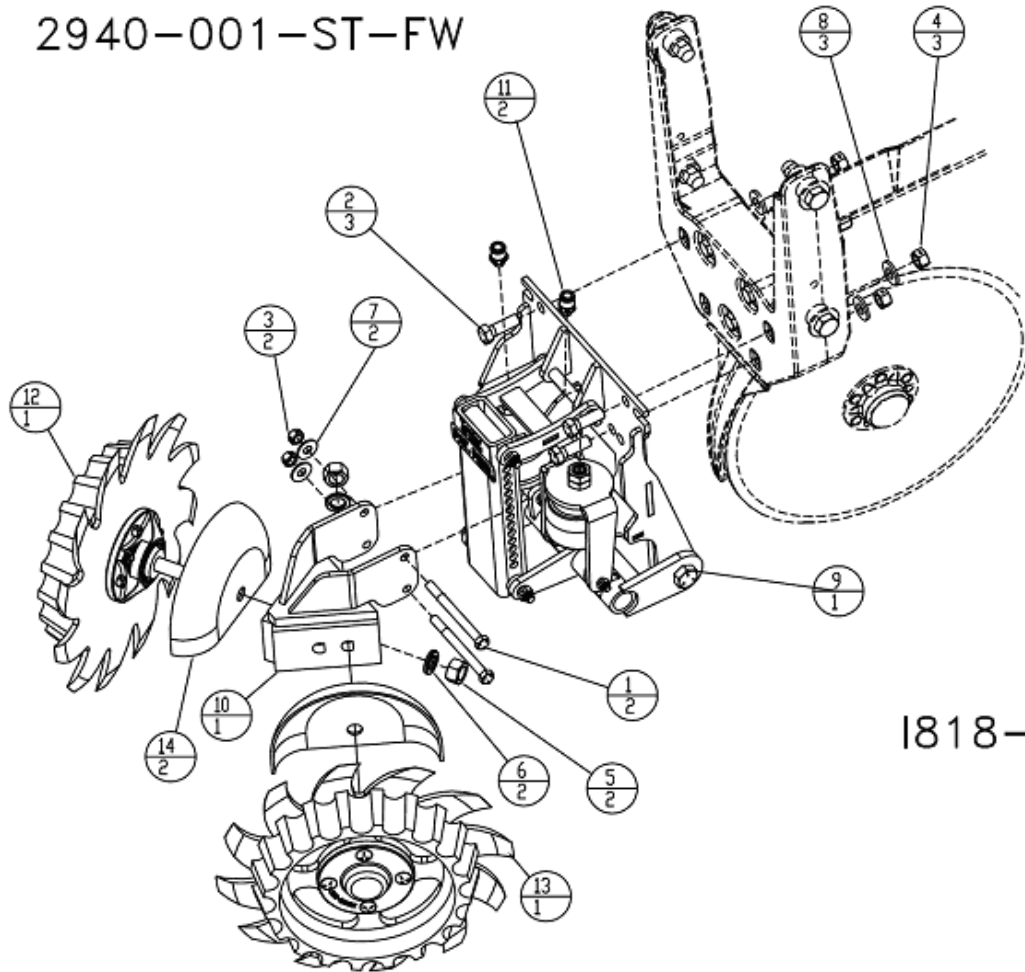

1818-1

ITEM	QTY	PART NO.	DESCRIPTION
1	2	2502-259	3/8-16 x 4-1/4 HHCS GR 5 ZP.
2	3	2502-294	1/2-13 X 1-1/2 HHCS GR5 ZP
3	2	2520-255	3/8-16 LOCK HEX NUT ZP.
4	3	2520-357	1/2-13 LOCK HEX NUT ZP
5	2	2520-452	5/8-11 HEXNUT ZP
6	2	2525-451	5/8 MED. LOCKWASHER ZP.
7	2	2526-251	3/8 STANDARD FLATWASHER ZP
8	3	2526-355	1/2 FLAT WASHER HARD'ND ZP
9	1	2940-140	PNEUMATIC R.M. MOUNT ASSEMBLY
10	1	2940-200	AIR ASSIST STEM W.A.
11	2	2940-339	3/8 PUSH CONNECT STRAIGHT 1/8 NPT MALE THREAD
12	1	2966-140	SPOKE WHEEL ASSY, RH, 3" D-BOLT
	1	2966-140-BW	BEVEL WHEEL ASSY, RH, 3" D-BOLT
	1	2966-140-BW-FW	BEVEL WHEEL ASSY, RH, 3" D-BOLT FLT WHL
	1	2966-140-FW	SPOKE WHEEL ASSY, RH, 3" D-BOLT FLT WHL
	1	2966-140-HD	HD SPOKE WHEEL ASSY, RH, 3" D-BOLT
	1	2966-140-HD-FW	HD FW SPOKE WHEEL ASSY, RH, 3" D-BOLT
	1	2966-140-ST	SHARKTOOH ASSY, RH, 3" D-BOLT
	1	2966-140-ST-FW	SHRKRTH ASSY,RH,3"D-BOLT FLT WL
13	1	2966-141	SPOKE WHEEL ASSY, LH, 3" D-BOLT
	1	2966-141-BW	BEVEL WHEEL ASSY, LH, 3" D-BOLT
	1	2966-141-BW-FW	BEVEL WHEEL ASSY, RH, 3" D-BOLT FLT WHL
	1	2966-141-FW	SPOKE WHEEL ASSY, RH, 3" D-BOLT FLT WHL
	1	2966-141-HD	HD SPOKE WHEEL ASSY, RH, 3" D-BOLT
	1	2966-141-HD-FW	HD FW SPOKE WHEEL ASSY, RH, 3" D-BOLT
	1	2966-141-ST	SHARKTOOH ASSY, RH, 3" D-BOLT
	1	2966-141-ST-FW	SHRKRTH ASSY,RH,3"D-BOLT FLT WL
14	2	2967-392	SHIELD, RM COMBO-PAINTED

MANUFACTURED 02/2013 - 09/2013

PARTS IDENTIFICATION

2940-002-ST-FW

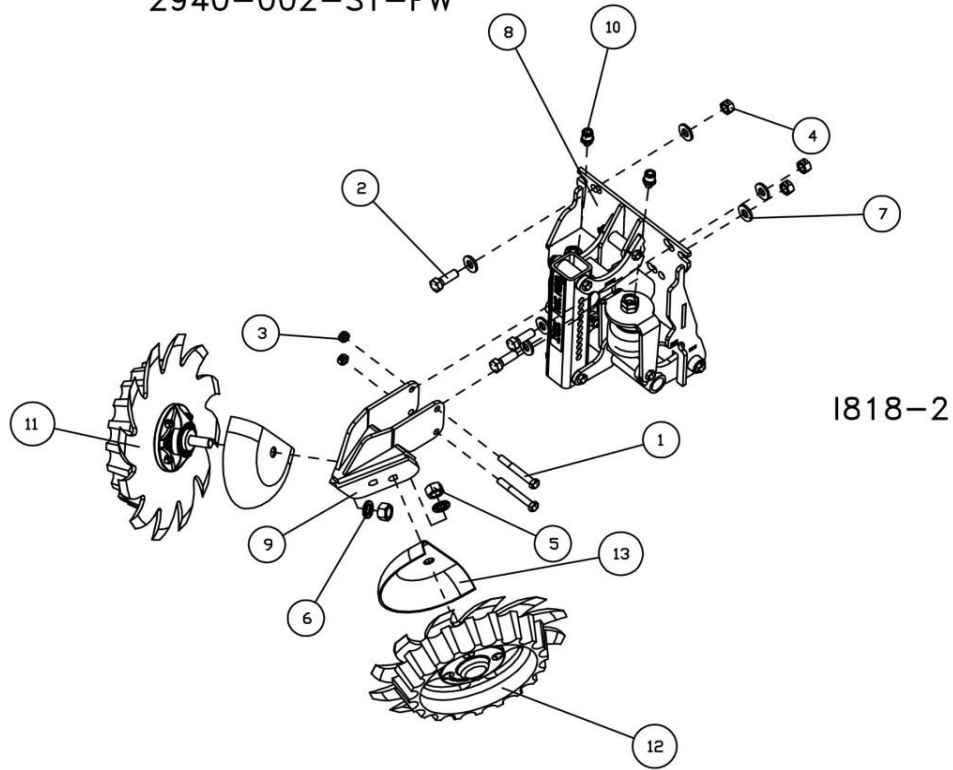

1818-2

ITEM	QTY	PART NO.	DESCRIPTION
1	2	2502-246	3/8-16 X 3 HHCS GR5 ZP
2	3	2502-294	1/2-13 X 1-1/2 HHCS GR5 YD
3	2	2520-255	3/8-16 LOCK HEX NUT ZP
4	3	2520-357	1/2-13 LOCK HEX NUT ZP
5	2	2520-452	5/8-11 HEXNUT ZP
6	2	2525-451	5/8 MED LOCKWASHER ZP
7	6	2526-355	1/2 FLAT WASHER HARD'ND ZYD
8	1	2940-190	PNEUMATIC R.M. MOUNT ASSEMBLY
9	1	2940-216	AIR ADJUST NARROW STEM W.A.
10	2	2940-339	3/8 PUSH CONNCT STRAIGHT 1/8 NPT MALE THREAD
11	1	2966-140	SPOKE WHEEL ASSY, RH, 3" D-BOLT
		2966-140-BW	BEVEL WHEEL ASSY, RH, 3" D-BOLT
		2966-140-BW-FW	BEVEL WHEEL ASSY, RH, 3" D-BOLT FLT WHL
		2966-140-FW	SPOKE WHEEL ASSY, RH, 3" D-BOLT FLT WHL
		2966-140-HD	HD SPOKE WHEEL ASSY, RH, 3" D-BOLT
		2966-140-HD-FW	HD FW SPOKE WHEEL ASSY, RH, 3" D-BOLT
		2966-140-ST	SHARKTOOH ASSY, RH, 3" D-BOLT
		2966-140-ST-FW	SHRKTH ASSY,RH,3"D-BOLT FLT WL
12	1	2966-141	SPOKE WHEEL ASSY, LH, 3" D-BOLT
		2966-141-BW	BEVEL WHEEL ASSY, LH, 3" D-BOLT
		2966-141-BW-FW	BEVEL WHEEL ASSY, LH, 3" D-BOLT FLT WHL
		2966-141-FW	SPOKE WHEEL ASSY, LH, 3" D-BOLT FLT WHL
		2966-141-HD	HD SPOKE WHEEL ASSY, LH, 3" D-BOLT
		2966-141-HD-FW	HD FW SPOKE WHEEL ASSY, LH, 3" D-BOLT
		2966-141-ST	SHARKTOOH ASSY, LH, 3" D-BOLT
		2966-141-ST-FW	SHRKTH ASSY,LH,3"D-BOLT FLT WL
13	2	2967-392	SHIELD, RM COMBO-PAINTED

MANUFACTURED 10/2013 - PRESENT

PARTS IDENTIFICATION

2940-002-ST-FW

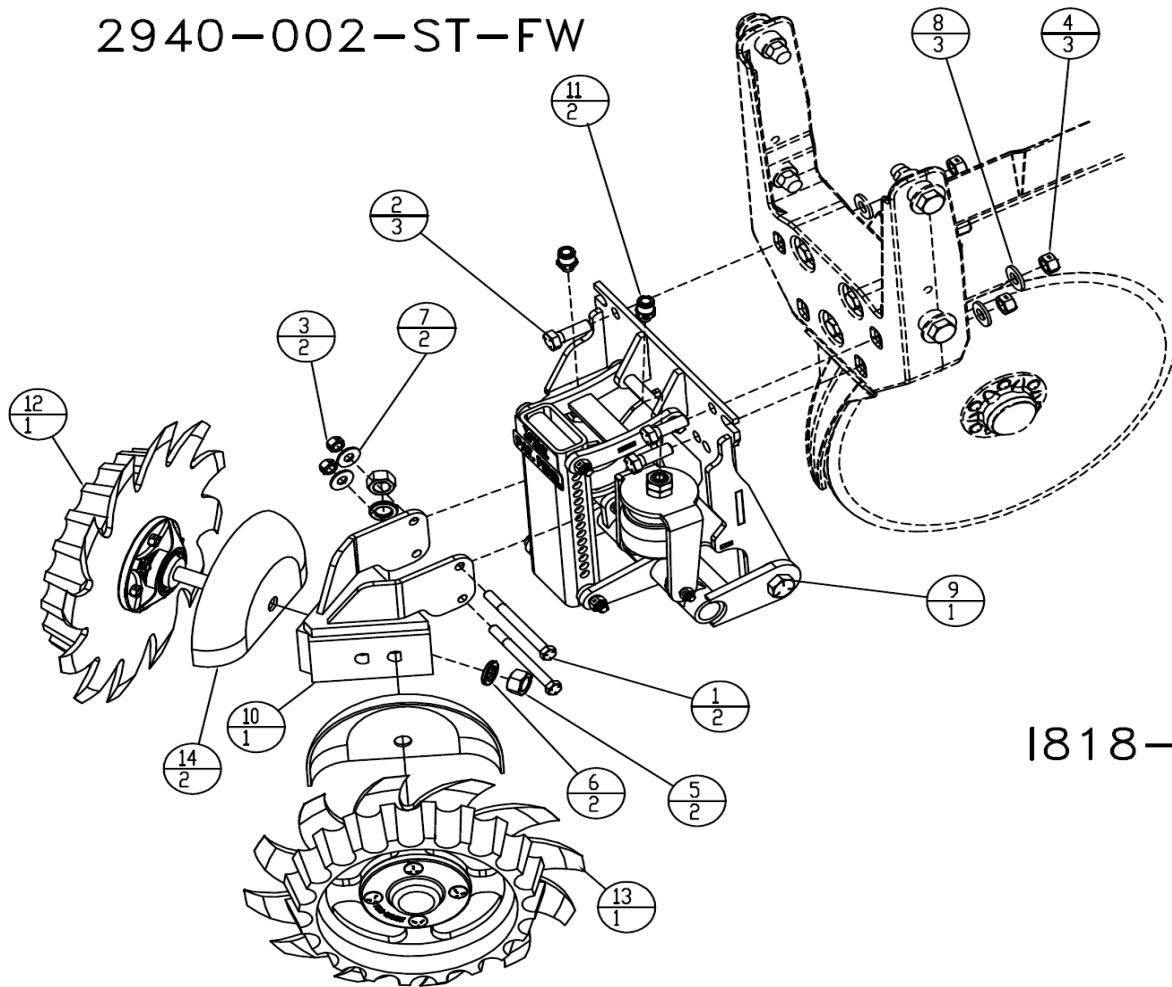

1818-2

ITEM	QTY	PART NO.	DESCRIPTION
1	2	2502-259	3/8-16 x 4-1/4 HHCS GR 5 ZP.
2	3	2502-294	1/2-13 X 1-1/2 HHCS GR5 ZP
3	2	2520-255	3/8-16 LOCK HEX NUT ZP.
4	3	2520-357	1/2-13 LOCK HEX NUT ZP
5	2	2520-452	5/8-11 HEXNUT ZP
6	2	2525-451	5/8 MED. LOCKWASHER ZP.
7	2	2526-251	3/8 STANDARD FLATWASHER ZP
8	3	2526-355	1/2 FLAT WASHER HARD'ND ZP
9	1	2940-140	PNEUMATIC R.M. MOUNT ASSEMBLY
10	1	2940-201	AIR ASSIST STEM W.A., NARROW
11	2	2940-339	3/8 PUSH CONNECT STRAIGHT 1/8 NPT MALE THREAD
12	1	2966-140	SPOKE WHEEL ASSY, RH, 3" D-BOLT
	1	2966-140-BW	BEVEL WHEEL ASSY, RH, 3" D-BOLT
	1	2966-140-BW-FW	BEVEL WHEEL ASSY, RH, 3" D-BOLT FLT WHL
	1	2966-140-FW	SPOKE WHEEL ASSY, RH, 3" D-BOLT FLT WHL
	1	2966-140-HD	HD SPOKE WHEEL ASSY, RH, 3" D-BOLT
	1	2966-140-HD-FW	HD FW SPOKE WHEEL ASSY, RH, 3" D-BOLT
	1	2966-140-ST	SHARKTOOH ASSY, RH, 3" D-BOLT
	1	2966-140-ST-FW	SHRKTH ASSY,RH,3"D-BOLT FLT WL
13	1	2966-141	SPOKE WHEEL ASSY, LH, 3" D-BOLT
	1	2966-141-BW	BEVEL WHEEL ASSY, LH, 3" D-BOLT
	1	2966-141-BW-FW	BEVEL WHEEL ASSY, RH, 3" D-BOLT FLT WHL
	1	2966-141-FW	SPOKE WHEEL ASSY, RH, 3" D-BOLT FLT WHL
	1	2966-141-HD	HD SPOKE WHEEL ASSY, RH, 3" D-BOLT
	1	2966-141-HD-FW	HD FW SPOKE WHEEL ASSY, RH, 3" D-BOLT
	1	2966-141-ST	SHARKTOOH ASSY, RH, 3" D-BOLT
	1	2966-141-ST-FW	SHRKTH ASSY,RH,3"D-BOLT FLT WL
14	2	2967-392	SHIELD, RM COMBO-PAINTED

MANUFACTURED 02/2013 - 09/2013

PARTS IDENTIFICATION

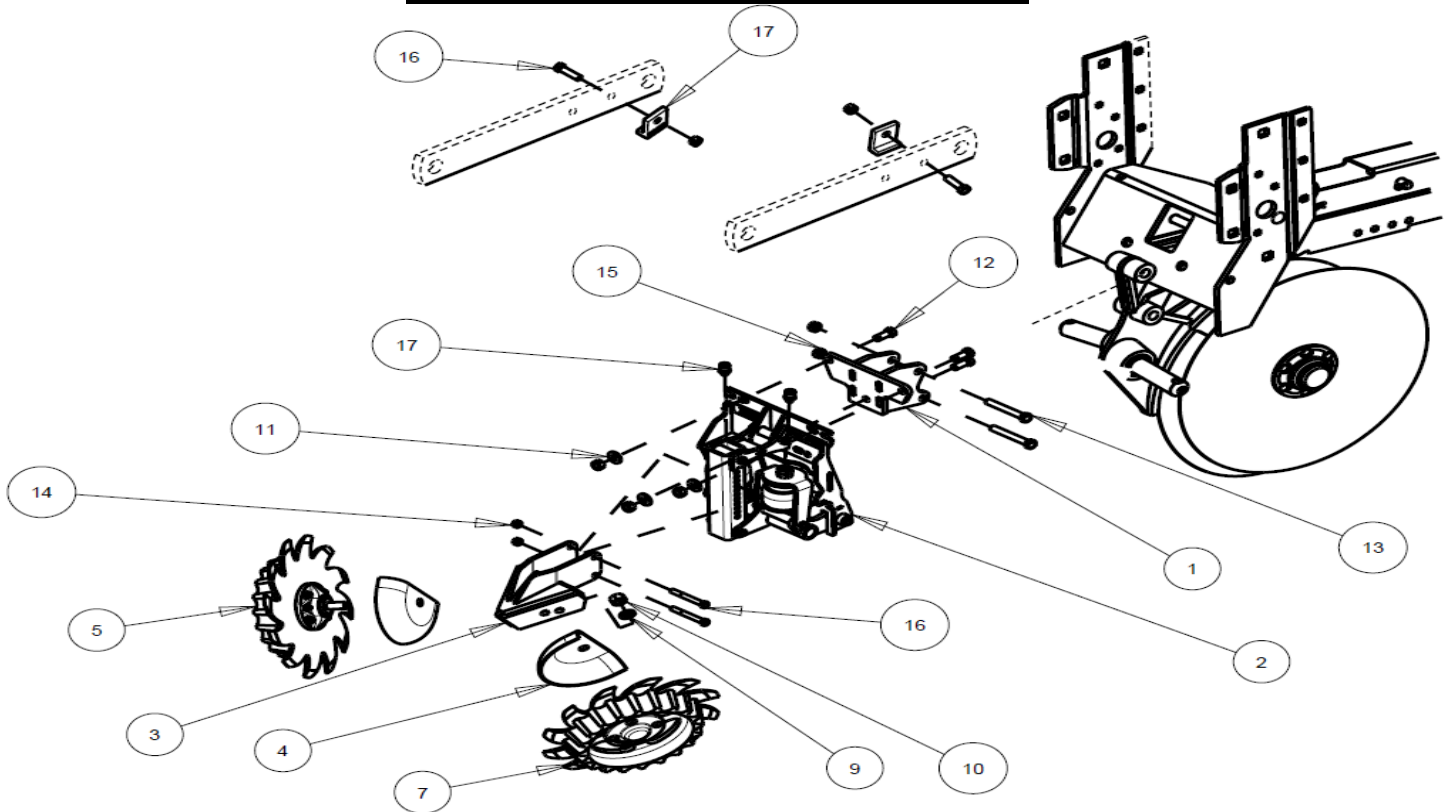

ITEM	PART #	DESCRIPTION	QTY
1	2940-209	MOUNT ADAPTER W.A., CNH	1
2	2940-190	PNEUMATIC R.M. MOUNT ASSEMBLY	1
3	2940-215	AIR ADJUST WIDE STEM W.A.	1
4	2967-392	SHIELD, RM COMBO-PAINTED	2
5	2966-140-ST-FW	SHRKTW WHEEL ASSY, RH, FW, 3"D-BOLT	1
-	2967-602	13" SHARK TOOTH WHEEL	1
-	2965-128	HUB & BEARING ASSY., 4 BOLT	1
-	2967-555	FLOATER WHEEL	1
-	2570-740	D-BOLT, FLGD, 5/8-11 X 2.812 GR. 8	1
-	2965-352	HUB CAP CASTING, 4 BOLT, BLACK	1
-	2505-209	5/16-18 X 1 3/4 CRBLT G5 YD	4
6	N10213	5/16-18 SERRATED FLNG NTZP	4
7	2966-141-ST-FW	SHRKTW WHEEL ASSY, LH, FW, 3" D-BOLT	1
-	2967-602	13" SHARK TOOTH WHEEL	1
-	2965-128	HUB & BEARING ASSY., 4 BOLT	1
-	2967-555	FLOATER WHEEL	1
-	2570-740	D-BOLT, FLGD, 5/8-11 X 2.812 GR. 8	1
-	2965-352	HUB CAP CASTING, 4 BOLT, BLACK	1
-	2505-209	5/16-18 X 1 3/4 CRBLT G5 YD	4
8	N10213	5/16-18 SERRATED FLNG NTZP	4
9	2525-451	5/8 MED. LOCKWASHER ZP.	2
10	2520-452	5/8-11 HEXNUT ZP	2
11	2526-355	1/2 FLAT WASHER HARD'ND ZYD	3
12	2502-293	1/2-13 X 1-1/4 HHCS GR5 YD	3
13	2502-316	1/2-13 X 3-1/2 HHCS GR5 ZP	2
14	2520-255	3/8-16 LOCK HEX NUT ZP	4
15	2520-357	1/2-13 LOCK HEX NUT ZP	5
16	2502-246	3/8-16 X 3 HHCS GR5 ZP	2
17	2940-339	3/8 PUSH CONNECT STRAIGHT 1/8 NPT MALE THREAD	2
16	2502-244	3/8-16 X 1-1/4 HHCS GR 5 ZP	2
17	2960-223	CYCLO STOP CASTING	2

On CNH planters with cable drive, check clearance with gear box housing and the wheels when the row unit and row cleaners near maximum up travel. If contact is made, a 2940-530 will need ordered per row.

MANUFACTURED 10/2013 - PRESENT

PARTS IDENTIFICATION

2940-003-ST-FW

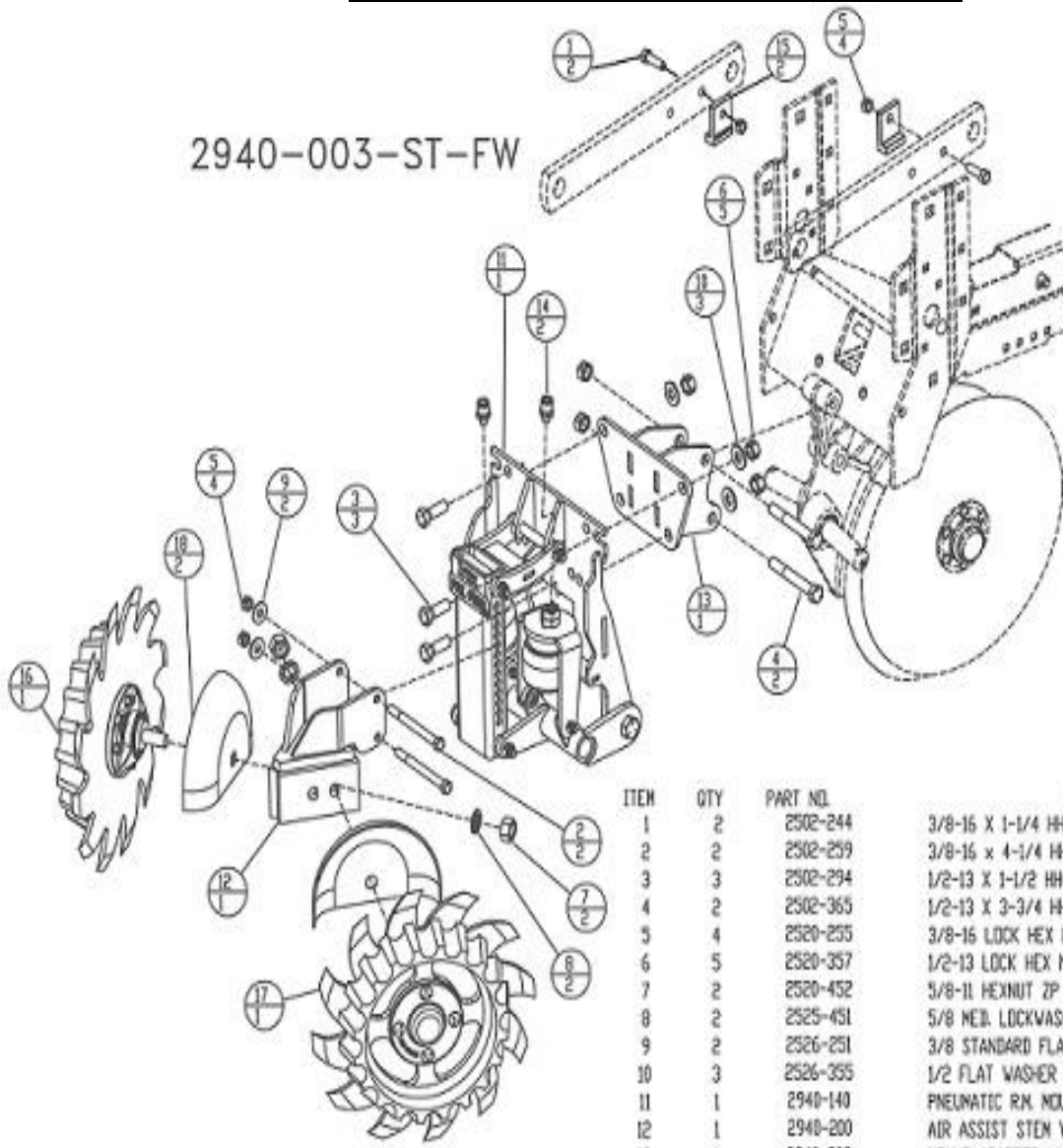

1818-3

ITEM	QTY	PART NO.	DESCRIPTION
1	2	2502-244	3/8-16 X 1-1/4 HHCS GR 5 ZP
2	2	2502-259	3/8-16 x 4-1/4 HHCS GR 5 ZP
3	3	2502-294	1/2-13 X 1-1/2 HHCS GR5 YD
4	2	2502-365	1/2-13 X 3-3/4 HHCS GR5 YD
5	4	2520-255	3/8-16 LOCK HEX NUT ZP
6	5	2520-357	1/2-13 LOCK HEX NUT ZP
7	2	2520-452	5/8-11 HEXNUT ZP
8	2	2525-451	5/8 MED. LOCKWASHER ZP.
9	2	2526-251	3/8 STANDARD FLATWASHER ZP
10	3	2526-355	1/2 FLAT WASHER HARDND ZYD
11	1	2940-140	PNEUMATIC RM. MOUNT ASSEMBLY
12	1	2940-200	AIR ASSIST STEM W.A.
13	1	2940-209	MOUNT ADAPTER W.A. CNH
14	2	2940-339	3/8 PUSH CONNECT STRAIGHT 1/8 NPT MALE THREAD
15	2	2960-223	CYCLD STOP CASTING
16	1	2966-140	SPOKE WHEEL ASSY, RH, 3" D-BOLT
	1	2966-140-BW	BEVEL WHEEL ASSY, RH, 3" D-BOLT
	1	2966-140-BW-FV	BEVEL WHEEL ASSY, RH, 3" D-BOLT FLT WHL
	1	2966-140-FV	SPOKE WHEEL ASSY, RH, 3" D-BOLT FLT WHL
	1	2966-140-HD	HD SPOKE WHEEL ASSY, RH, 3" D-BOLT
	1	2966-140-HD-FV	HD FV SPOKE WHEEL ASSY, RH, 3" D-BOLT
	1	2966-140-ST	SHARKTOOTH ASSY, RH, 3" D-BOLT
	1	2966-140-ST-FV	SHRKT ASSY,RH,3"D-BOLT FLT WL
17	1	2966-141	SPOKE WHEEL ASSY, LH, 3" D-BOLT
	1	2966-141-BW	BEVEL WHEEL ASSY, LH, 3" D-BOLT
	1	2966-141-BW-FV	BEVEL WHEEL ASSY, RH, 3" D-BOLT FLT WHL
	1	2966-141-FV	SPOKE WHEEL ASSY, RH, 3" D-BOLT FLT WHL
	1	2966-141-HD	HD SPOKE WHEEL ASSY, RH, 3" D-BOLT
	1	2966-141-HD-FV	HD FV SPOKE WHEEL ASSY, RH, 3" D-BOLT
	1	2966-141-ST	SHARKTOOTH ASSY, RH, 3" D-BOLT
	1	2966-141-ST-FV	SHRKT ASSY,RH,3"D-BOLT FLT WL
18	2	2967-392	SHIELD, RN COMBO-PAINTED

MANUFACTURED 02/2013 - 09/2013

PARTS IDENTIFICATION

2940-004-ST-FW

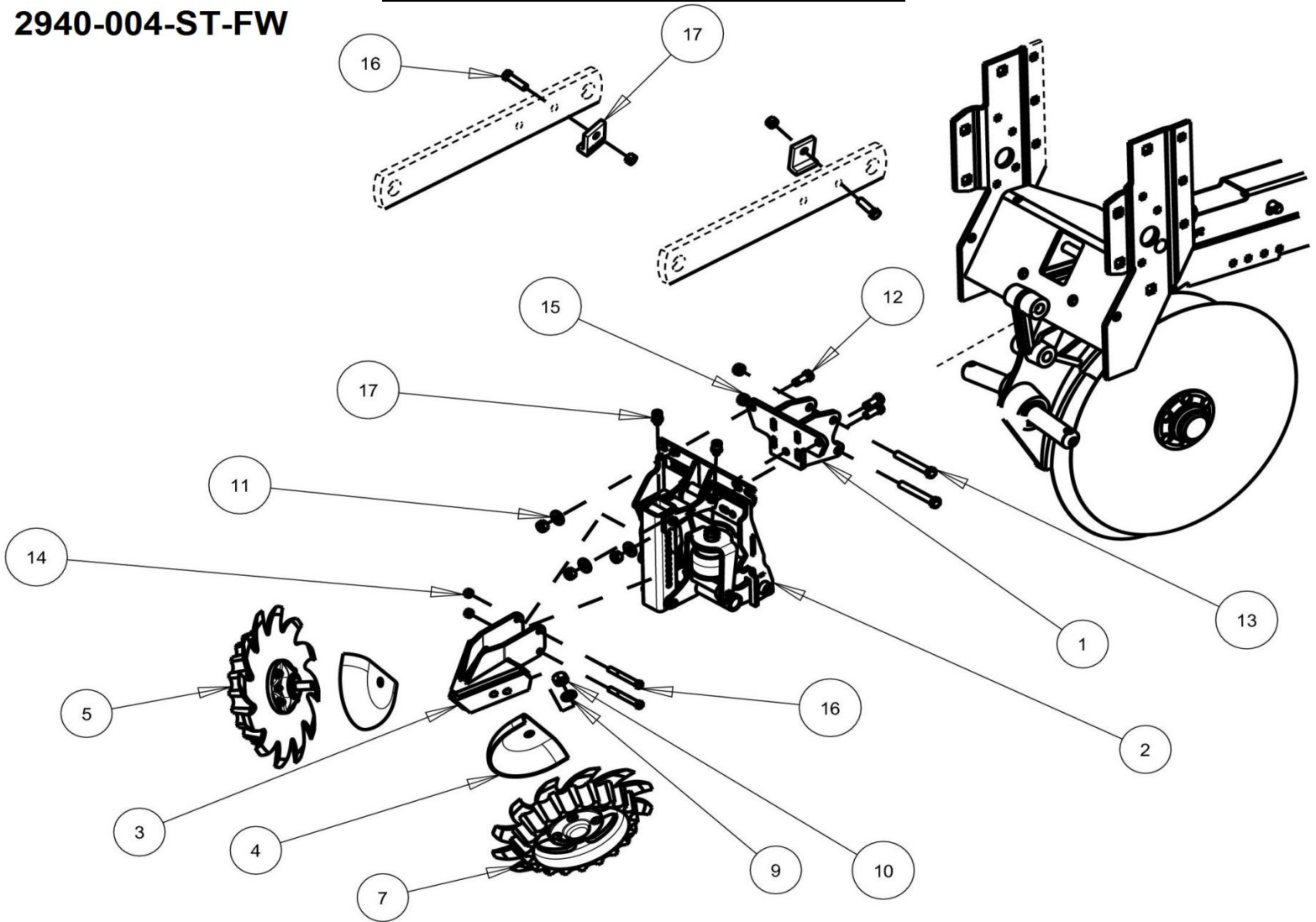

ITEM	PART #	DESCRIPTION	QTY
1	2940-209	MOUNT ADAPTER W.A., CNH	1
2	2940-190	PNEUMATIC R.M. MOUNT ASSEMBLY	1
3	2940-216	AIR ADJUST NARROW STEM W.A.	1
4	2967-392	SHIELD, RM COMBO-PAINTED	2
5	2966-140-ST-FW	SHRKTW WHEEL ASSY, RH, FW, 3"D-BOLT	1
-	2967-602	13" SHARK TOOTH WHEEL	1
-	2965-128	HUB & BEARING ASS'Y., 4 BOLT	1
-	2967-555	FLOATER WHEEL	1
-	2570-740	D-BOLT, FLGD, 5/8-11 X 2.812 GR. 8	1
-	2965-352	HUB CAP CASTING, 4 BOLT, BLACK	1
-	2505-209	5/16-18 X 1 3/4 CRBLT G5 YD	4
6	N10213	5/16-18 SERRATED FLNG NTZP	4
7	2966-141-ST-FW	SHRKTW WHEEL ASSY, LH, FW, 3" D-BOLT	1
-	2967-602	13" SHARK TOOTH WHEEL	1
-	2965-128	HUB & BEARING ASS'Y., 4 BOLT	1
-	2967-555	FLOATER WHEEL	1
-	2570-740	D-BOLT, FLGD, 5/8-11 X 2.812 GR. 8	1
-	2965-352	HUB CAP CASTING, 4 BOLT, BLACK	1
-	2505-209	5/16-18 X 1 3/4 CRBLT G5 YD	4
8	N10213	5/16-18 SERRATED FLNG NTZP	4
9	2525-451	5/8 MED. LOCKWASHER ZP.	2
10	2520-452	5/8-11 HEXNUT ZP	2
11	2526-355	1/2 FLAT WASHER HARD'ND ZYD	3
12	2502-293	1/2-13 X 1-1/4 HHCS GR5 YD	3
13	2502-316	1/2-13 X 3-1/2 HHCS GR5 ZP	2
14	2520-255	3/8-16 LOCK HEX NUT ZP	4

MANUFACTURED 10/2013 - PRESENT

PARTS IDENTIFICATION

2940-004-ST-FW

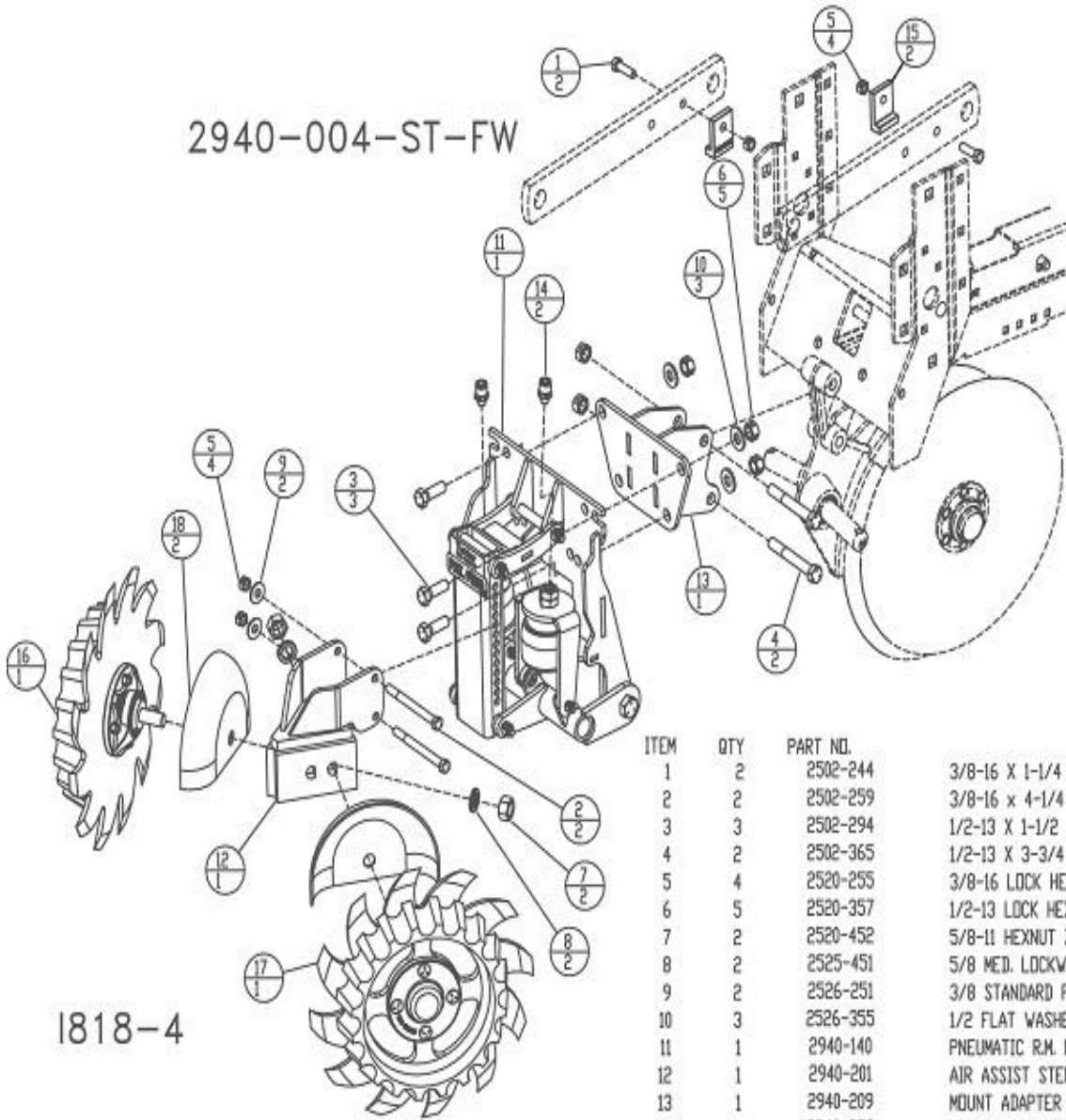

1818-4

ITEM	QTY	PART NO.	DESCRIPTION
1	2	2502-244	3/8-16 X 1-1/4 HHCS GR 5 ZP
2	2	2502-259	3/8-16 x 4-1/4 HHCS GR 5 ZP.
3	3	2502-294	1/2-13 X 1-1/2 HHCS GR5 YD
4	2	2502-365	1/2-13 X 3-3/4 HHCS GR5 YD
5	4	2520-255	3/8-16 LOCK HEX NUT ZP
6	5	2520-357	1/2-13 LOCK HEX NUT ZP
7	2	2520-452	5/8-11 HEXNUT ZP
8	2	2525-451	5/8 MED. LOCKWASHER ZP.
9	2	2526-251	3/8 STANDARD FLATWASHER ZP
10	3	2526-355	1/2 FLAT WASHER HARD'ND ZYD
11	1	2940-140	PNEUMATIC R.M. MOUNT ASSEMBLY
12	1	2940-201	AIR ASSIST STEM W.A., NARROW
13	1	2940-209	MOUNT ADAPTER W.A., CNH
14	2	2940-339	3/8 PUSH CONNECT STRAIGHT 1/8 NPT MALE THREAD
15	2	2960-223	CYCLD STOP CASTING
16	1	2966-140	SPOKE WHEEL ASSY, RH, 3' D-BOLT
	1	2966-140-BW	BEVEL WHEEL ASSY, RH, 3' D-BOLT
	1	2966-140-BW-FW	BEVEL WHEEL ASSY, RH, 3' D-BOLT FLT WHL
	1	2966-140-FW	SPOKE WHEEL ASSY, RH, 3' D-BOLT FLT WHL
	1	2966-140-HD	HD SPOKE WHEEL ASSY, RH, 3' D-BOLT
	1	2966-140-HD-FW	HD FW SPOKE WHEEL ASSY, RH, 3' D-BOLT
	1	2966-140-ST	SHARKTOOTH ASSY, RH, 3' D-BOLT
	1	2966-140-ST-FW	SHRKTH ASSY,RH,3'D-BOLT FLT WL
17	1	2966-141	SPOKE WHEEL ASSY, LH, 3' D-BOLT
	1	2966-141-BW	BEVEL WHEEL ASSY, LH, 3' D-BOLT
	1	2966-141-BW-FW	BEVEL WHEEL ASSY, RH, 3' D-BOLT FLT WHL
	1	2966-141-FW	SPOKE WHEEL ASSY, RH, 3' D-BOLT FLT WHL
	1	2966-141-HD	HD SPOKE WHEEL ASSY, RH, 3' D-BOLT
	1	2966-141-HD-FW	HD FW SPOKE WHEEL ASSY, RH, 3' D-BOLT
	1	2966-141-ST	SHARKTOOTH ASSY, RH, 3' D-BOLT
	1	2966-141-ST-FW	SHRKTH ASSY,RH,3'D-BOLT FLT WL
18	2	2967-392	SHIELD, RM COMBO-PAINTED

MANUFACTURED 02/2013 - 09/2013

PARTS IDENTIFICATION

2940-010

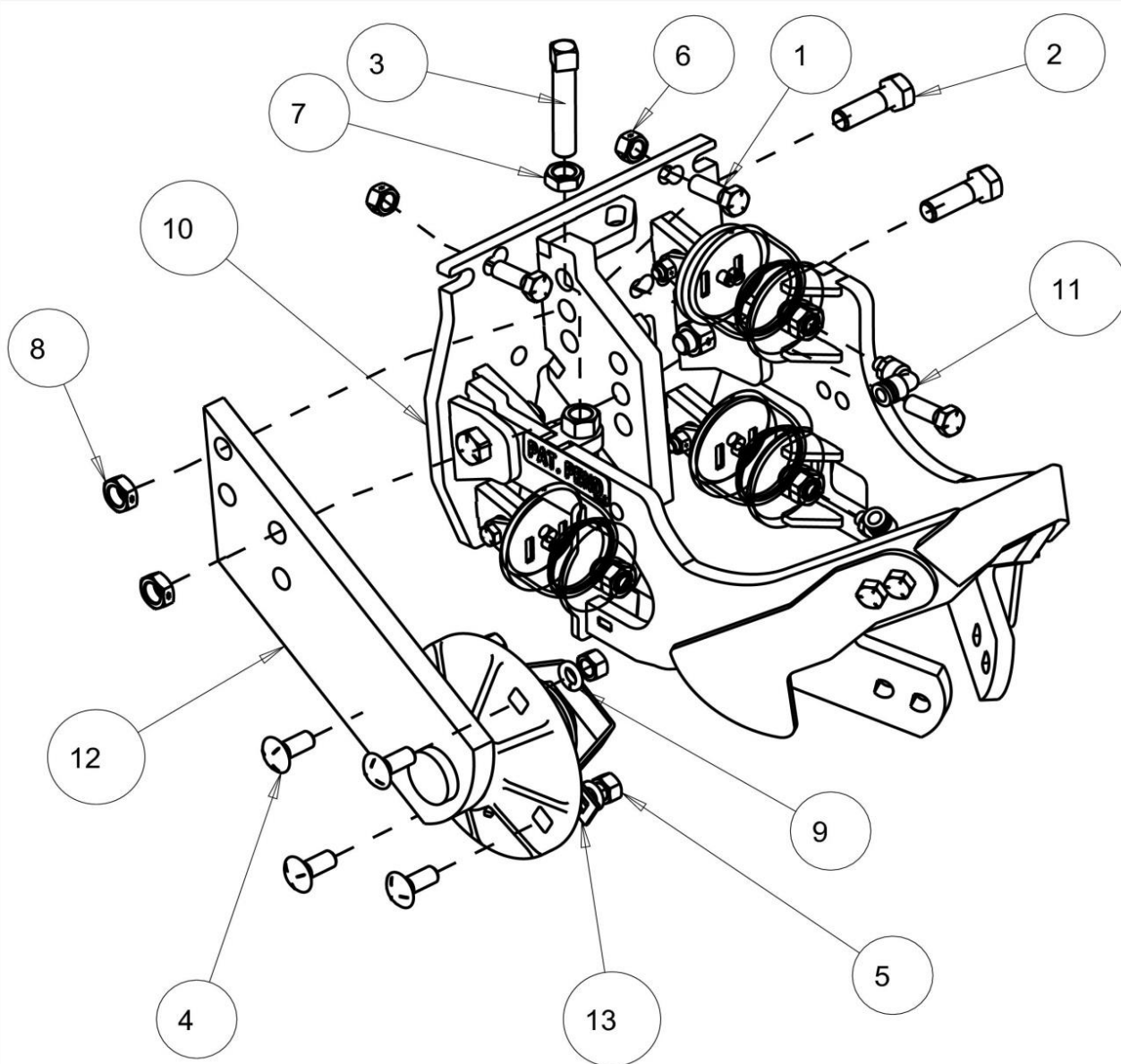

ITEM	PART #	DESCRIPTION	QTY
1	2502-294	1/2-13 X 1-1/2 HHCS GR5 YD	3
2	2502-391	5/8-11 X 2 HHCS GR 5 ZP	2
3	2503-388	5/8-11 X 2-1/2 CP SET SCREW ZP	1
4	2505-337	1/2-13 X 1 1/4 CARBLT G5ZP	4
5	2520-352	1/2-13 HEX NUT ZP	4
6	2520-357	1/2-13 LOCK HEX NUT ZP	3
7	2520-453	5/8-11 JAM HEX NUT ZP	1
8	2520-467	WU/ 5/8-11 HEX LOCKNUT JAM ZP	2
9	2525-352	1/2 MED LOCKWASHER ZP.	4
10	2940-191	COMBO AIR ADJUST ASSEMBLY	1
11	2940-337	3/8 PUSH CONNECT ELBOW 1/8 NPT MALE THREAD	3
12	2960-133	COULTER ARM ASSEMBLY	1
13	2987-301	HUB CAP RETAINER	1

2940-010

2940-191 PART IDENTIFICATION

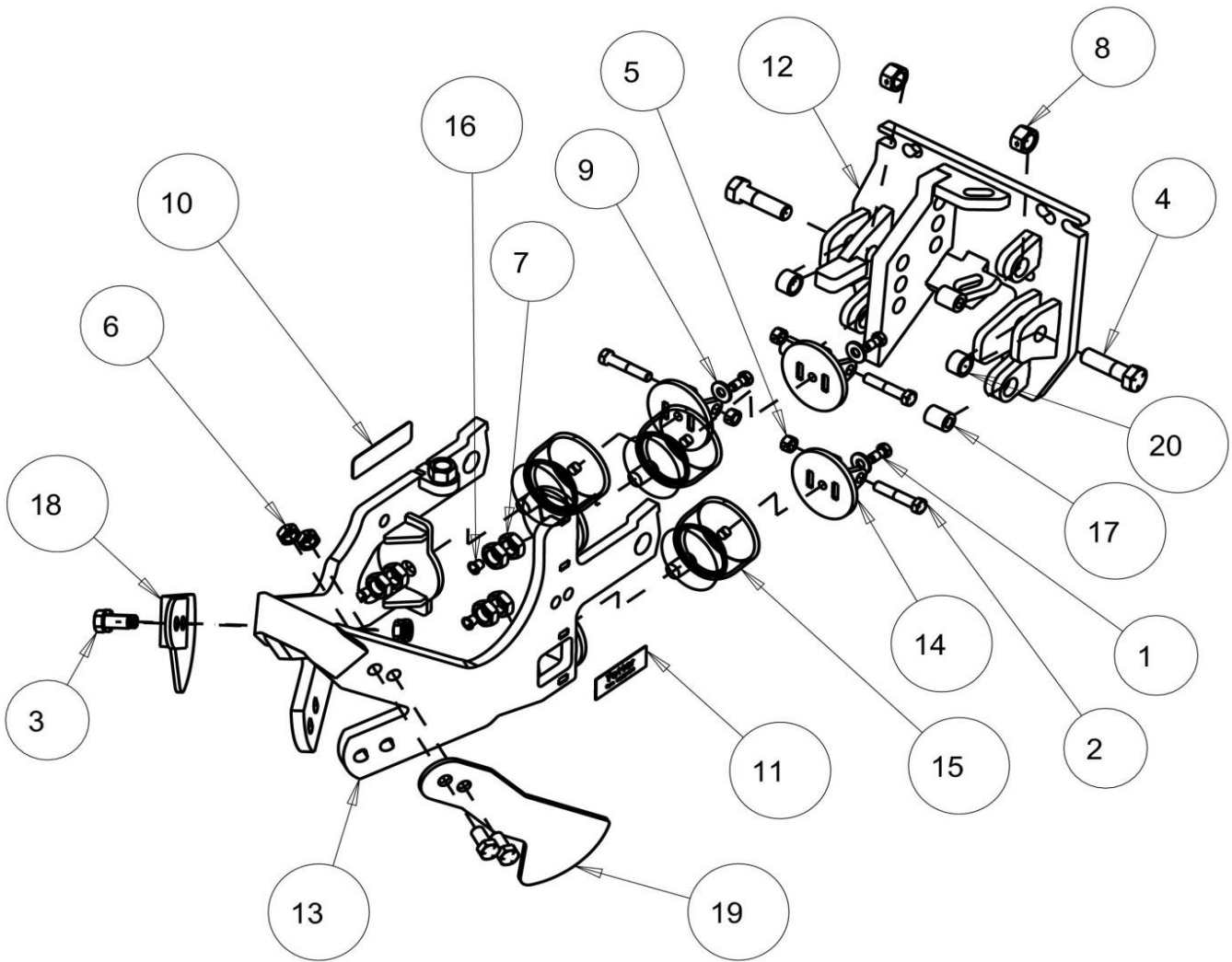

ITEM	PART #	DESCRIPTION	QTY
1	2502-200	5/16-18 X 3/4 HHCS W/THD LCK GR 2 ZP	3
2	2502-240	3/8-16 X 2 HHCS GR5 ZP	3
3	2502-292	1/2-13 X 1 HHCS GR5 YD	4
4	2502-332	5/8-11 X 2-1/4 HHCS GR5 ZP	2
5	2520-255	3/8-16 LOCK HEX NUT ZP	3
6	2520-364	WU/ 1/2-13 HEX LOCKNUT JAM ZP	4
7	2520-454	5/8-11 BRASS JAM NUT	6
8	2520-459	5/8-11 LOCK HEX NUT ZP	2
9	2526-201	5/16STANDARD FLATWASHER ZP	3
10	2565-071	PATENT PENDING DECAL	1
11	2565-179	YETTER DECAL, 1 X 3	1
12	2940-217	FACEPLATE W.A.	1
13	2940-218	COMBO ARM W.A.	1
14	2940-219	AIR BAG MOUNT W.A.	3
15	2940-306	FPE SK-37-6" SMALLER AIR BAG	3
16	2940-340	CAP PLUG - 171201HB L-2 PE-LD01R	3
17	2940-496	BUSHING	3
18	2967-630	SCRAPER, R.H.	1
19	2967-631	SCRAPER, L.H.	1
20	6000-335	9/16" BUSHING	2

2940-191ISO

PARTS IDENTIFICATION

2960-133

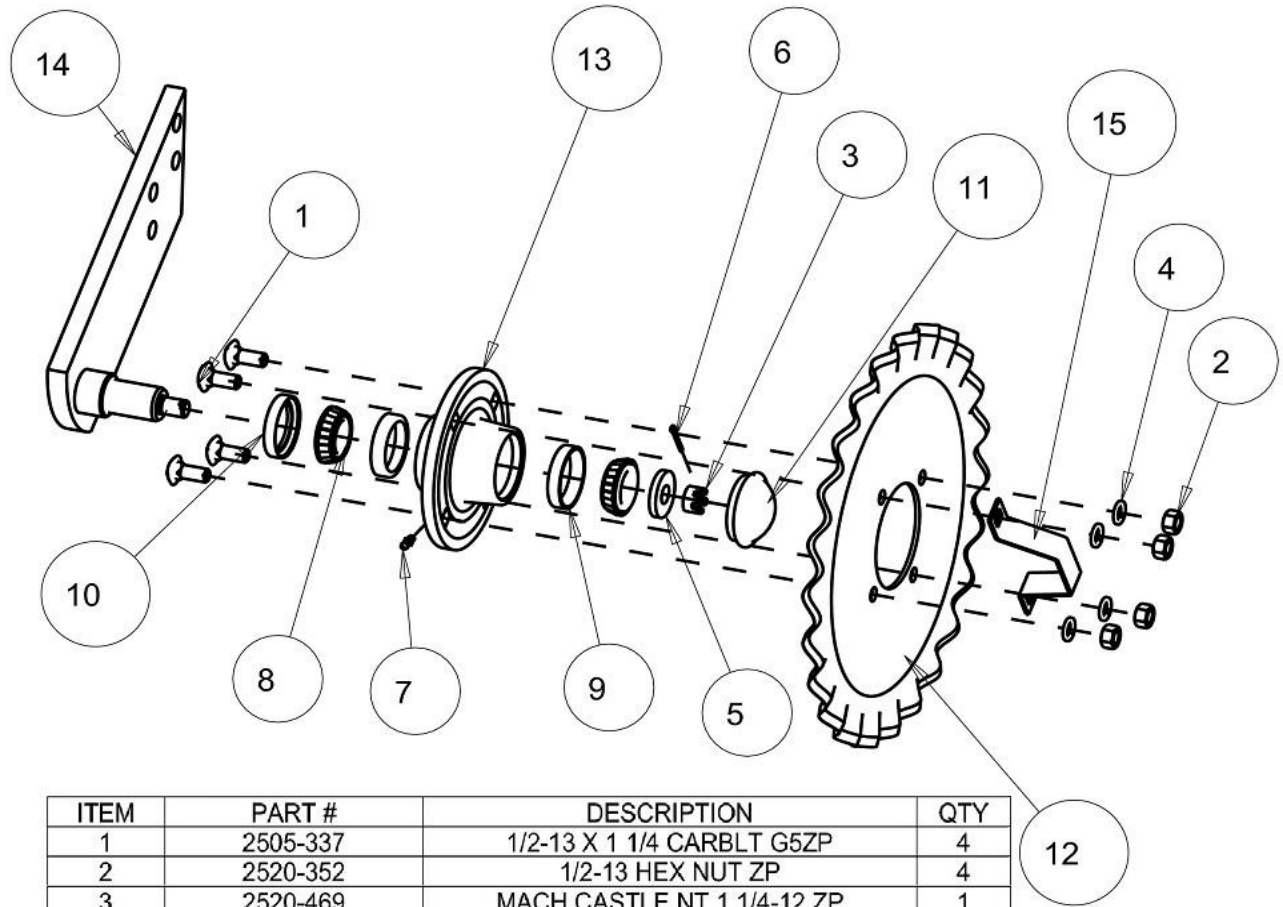

ITEM	PART #	DESCRIPTION	QTY
1	2505-337	1/2-13 X 1 1/4 CARBLT G5ZP	4
2	2520-352	1/2-13 HEX NUT ZP	4
3	2520-469	MACH CASTLE NT 1 1/4-12 ZP	1
4	2525-352	1/2 MED LOCKWASHER ZP.	4
5	2526-449	5/8FLATWASHER1/4+- .010 THK	1
6	2531-102	WU/ 5/16 X 2-1/2 COTTER PIN ZP	1
7	2533-110	1/4-28 ZERK STRAIGHT SELF-TAP	1
8	2550-027	CONE, LM67048	2
9	2550-029	CUP, LM67010	2
10	2550-115	SEAL (CR#16069) (YETTER 2550-066)	1
11	2570-375	HUB CAP, WILTON #909902	1
12	2571-BLADE OPT	BLADE OPTIONS	1
	2571-172	.157X 15.81" 25 FLUTE BLADE	
	2571-162	.157X 15.937" 13 FLUTE BLADE	
	2571-206	.197X 16 SMOOTH COULTER BLADE	
	2571-161	.157 X 17" RIPPLE BLADE	
	2571-156	.157X 15.81" 8 FLUTE BLADE	
	2571-153	.157 X 16" BUBBLE BLADE	
13	2900-105	HUB PRESSED ASSEMBLY	1
14	2960-230	COULTER ARM W.A.	1
15	2987-301	HUB CAP RETAINER	1

2960-133

PARTS IDENTIFICATION

2940-082

5X7 & 7X7 BAR MOUNT KIT

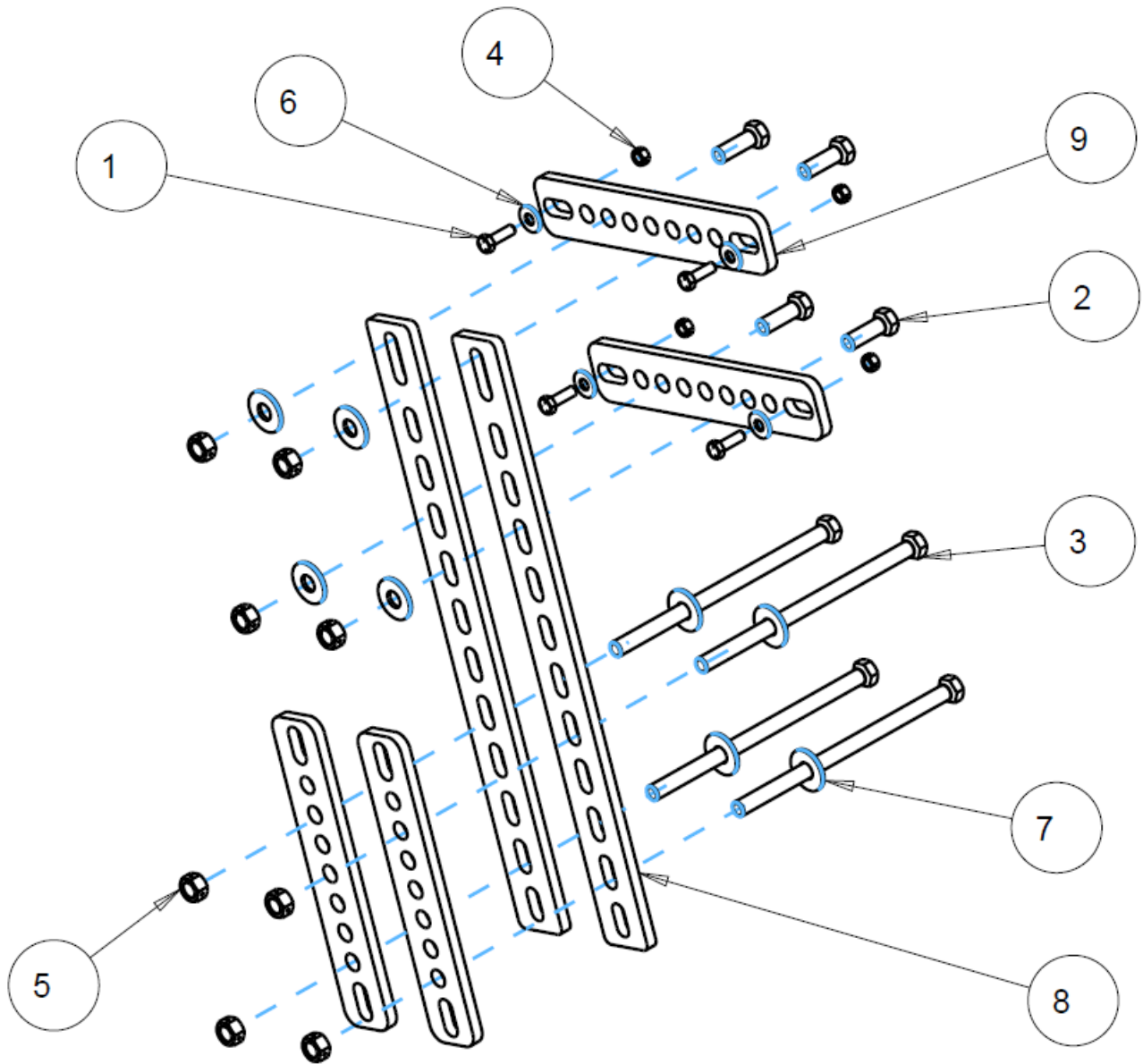

ITEM	PART #	DESCRIPTION	QTY
1	2502-198	5/16-18 X 1 HHCS GR.5 ZP	4
2	2502-294	1/2-13 X 1-1/2 HHCS GR5 YD	4
3	2502-374	1/2-13 X 9 HHCS GR. 5 ZP	4
4	2520-205	5/16-18 LOCK HEX NUT ZP	4
5	2520-357	1/2-13 LOCK HEX NUT ZP	8
6	2526-201	5/16STANDARD FLATWASHER ZP	4
7	2526-351	1/2 STANDARD FLATWASHER ZP	8
8	2940-344	MOUNT STRAP	2
9	2940-355	MOUNT STRAP	4

PARTS IDENTIFICATION

2940-083

8X16 & 8X12 BAR MOUNT KIT

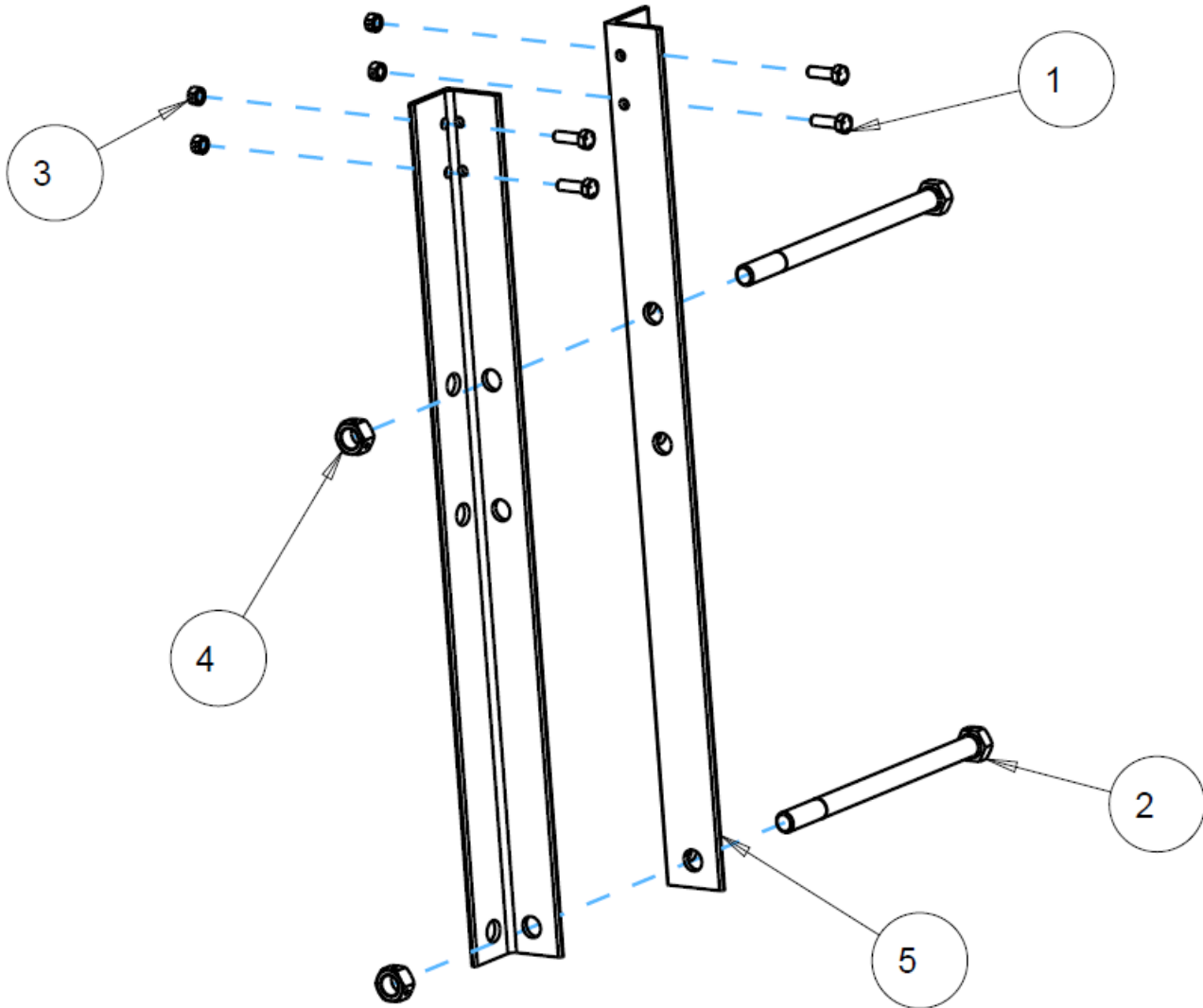

ITEM	PART #	DESCRIPTION	QTY
1	2502-198	5/16-18 X 1 HHCS GR.5 ZP	4
2	2502-398	5/8-11 X 9-1/2 HHCS GR5 ZP	2
3	2520-205	5/16-18 LOCK HEX NUT ZP	4
4	2520-459	5/8-11 LOCK HEX NUT ZP	2
5	2940-479	ANGLE MOUNT BRACKET	2

PARTS IDENTIFICATION

2940-084

UNIVERSAL HAND RAIL MOUNT KIT

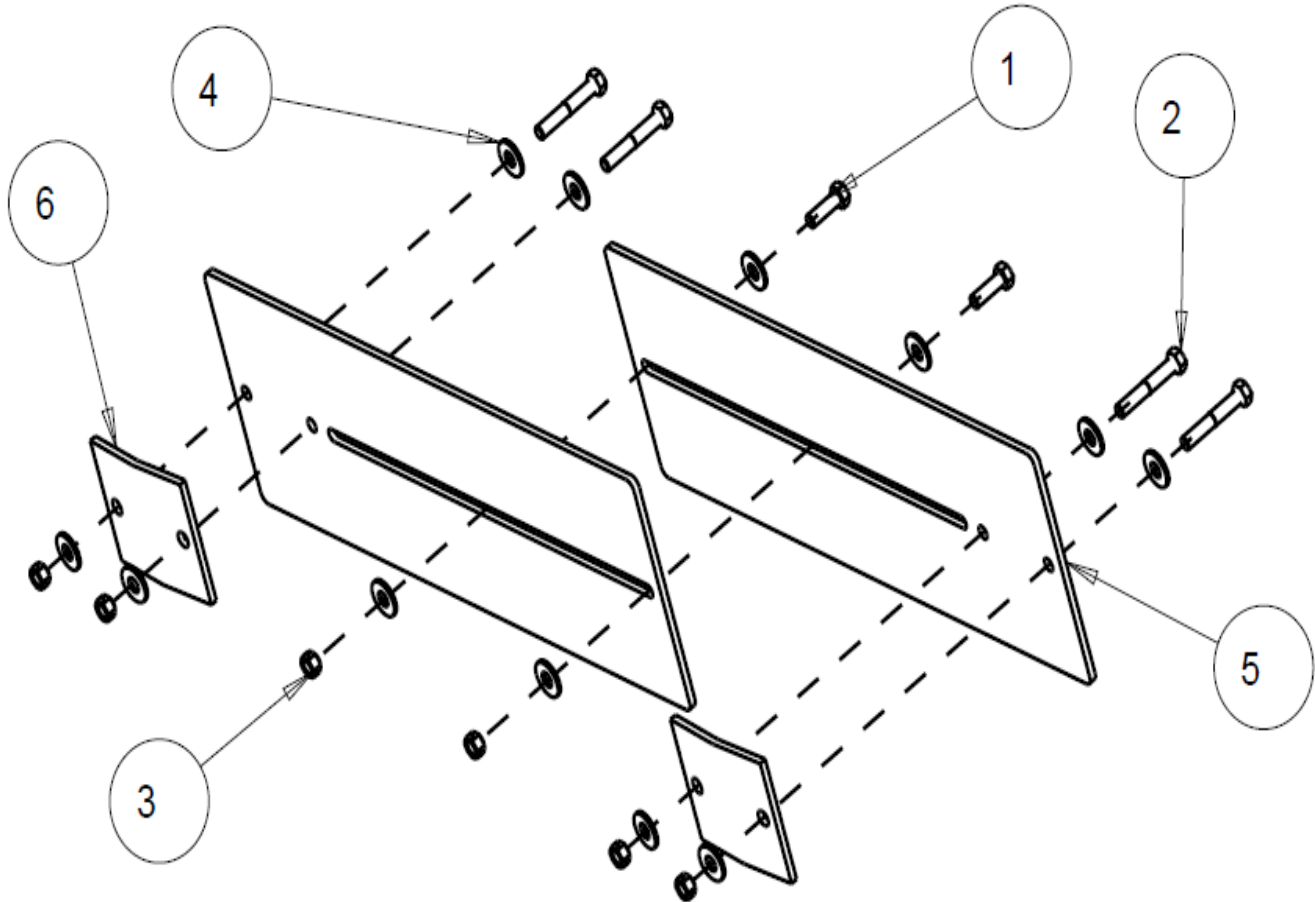

ITEM	PART #	DESCRIPTION	QTY
1	2502-198	5/16-18 X 1 HHCS GR.5 ZP	2
2	2502-207	5/16-18 X 2 HHCS GR5 ZP	4
3	2520-205	5/16-18 LOCK HEX NUT ZP	6
4	2526-201	5/16STANDARD FLATWASHER ZP	12
5	2940-480	HAND RAIL TELESCOPING PLATE	2
6	2940-481	HAND RAIL CLAMP	2

PARTS IDENTIFICATION

2940-085

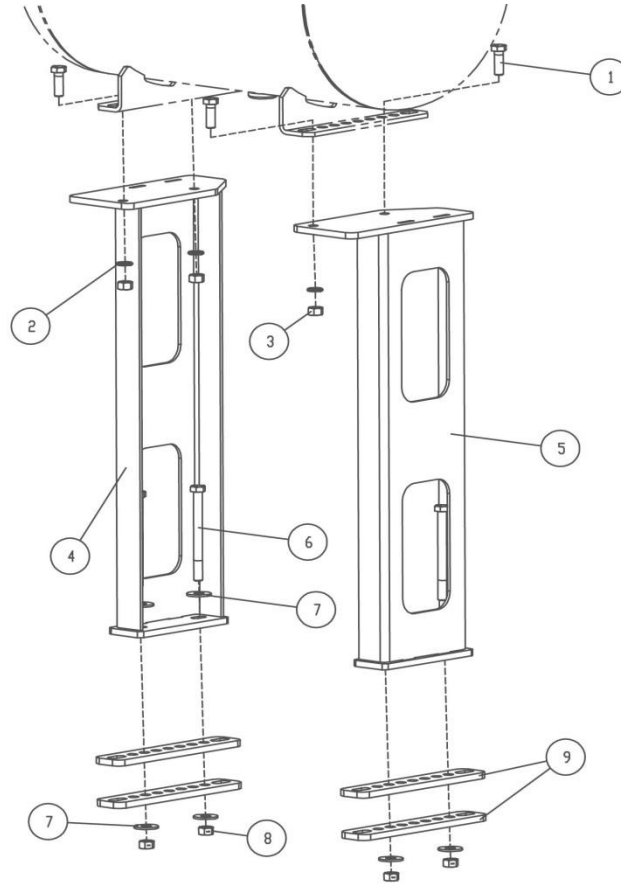

2940-085 TWO POINT OR UNIVERSAL COMPRESSOR MOUNT KIT

ITEM	QTY	PART NO.	DESCRIPTION
1	4	2502-294	1/2-13 X 1-1/2 HHCS GR 5 ZP.
2	4	2525-352	1/2 MED LOCKWASHER ZP
3	4	2520-352	1/2-13 HEX NUT ZP.
4	1	2940-207	COMPRESSOR MOUNT W.A., L.H.
5	1	2940-208	COMPRESSOR MOUNT W.A., R.H.
6	4	2502-368	1/2-13 X 5-1/2 HHCS GR 5 ZP.
7	4	2526-351	1/2 STANDARD FLATWASHER ZP.
8	4	2520-357	1/2-13 LOCK HEX NUT ZP
9	4	2940-355	MOUNT STRAP

PARTS IDENTIFICATION

2940-086

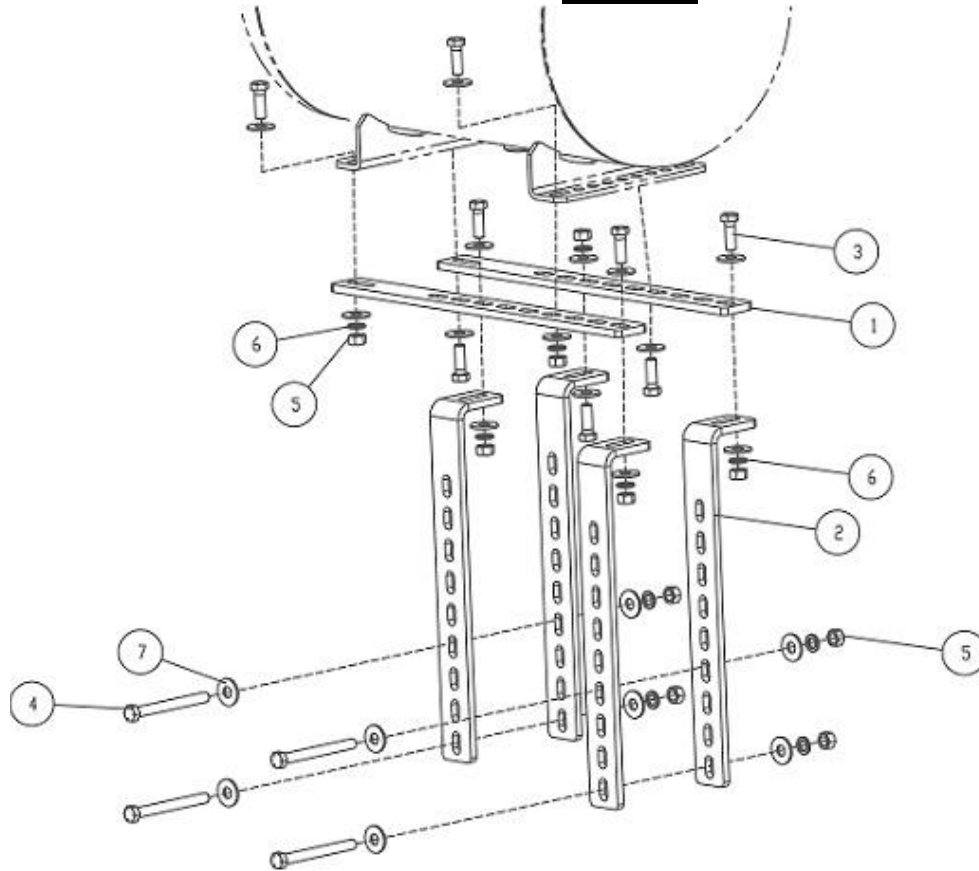

2940-086 DRAFT TUBE OR UNIVERSAL MOUNT KIT

ITEM	QTY	PART NO.	DESCRIPTION
1	2	2940-344	COMPRESSOR STRAP
2	4	2940-351	COMPRESSOR MOUNT BRACKET
3	8	2502-294	1/2-13 X 1-1/2 HHCS GR 5 ZP. (ONLY 6 SHOWN)
4	4	2502-349	1/2-13 X 5 FLTHD HHCS GR 5 ZP.
5	12	2520-352	1/2-13 HEX NUT ZP.
6	12	2525-352	1/2 MED LOCKWASHER ZP.
7	20	2526-351	1/2 STANDARD FLATWASHER ZP.

PARTS IDENTIFICATION

2940-090 & 2940-091

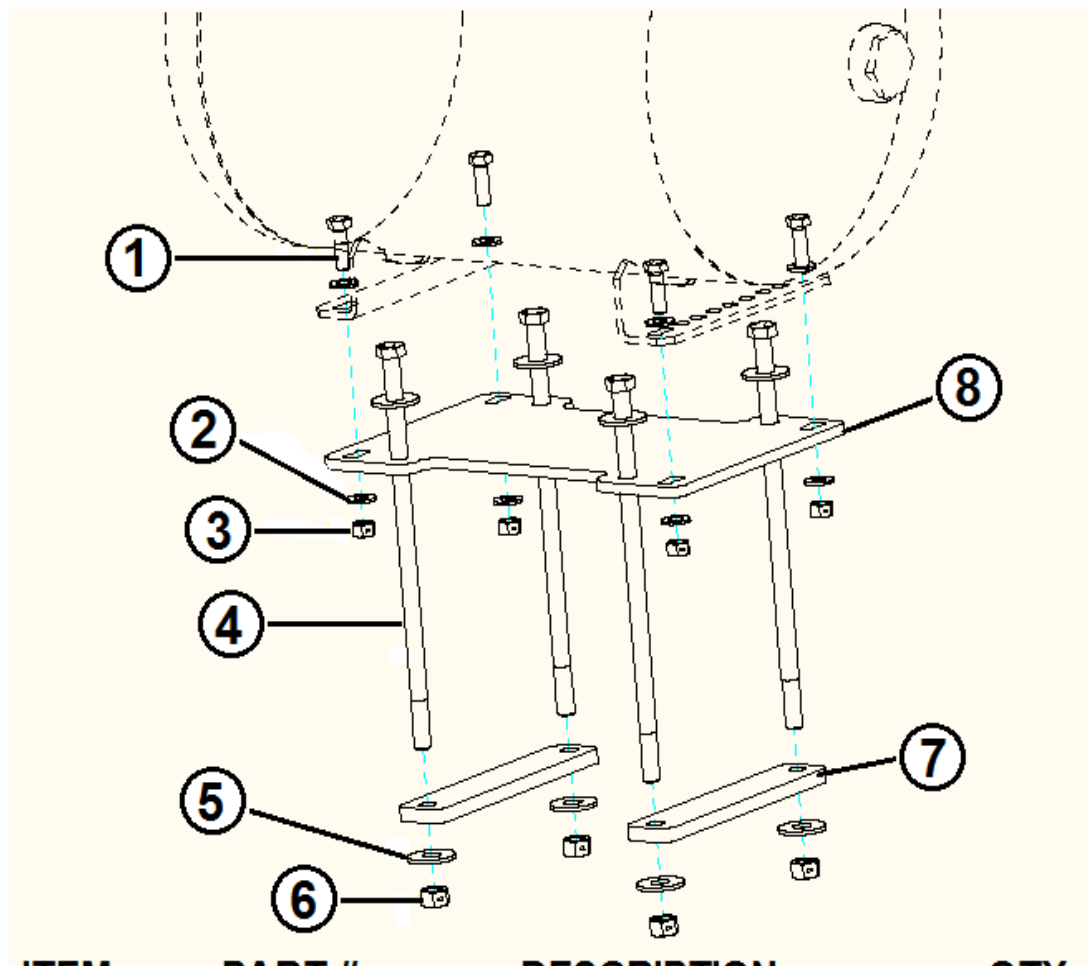

ITEM	PART #	DESCRIPTION	QTY
1	2502-294	1/2-13 X 1-1/2 HHCS GR 5	4
2	2526-352	1/2 SAE FLATWASHER ZP	8
3	2520-357	1/2-13 LOCK HEX NUT ZP	4
4	2502-388	5/8-11 X 14 HHCS GR 5 ZP	4 (2940-090)
4	2502-389	5/8-11 X 18 HHCS GR 5 ZP	4 (2940-091)
5	2526-451	5/8 STD FLATWASHER ZP	8
6	2520-459	5/8-11 LOCK HEX NUT ZP	4
7	2940-373	MOUNT STRAP	2
8	2940-372	HYD. COMP. MOUNT PLATE	1

ITEM 4 BOLT LENGTH IS THE ONLY DIFFERENCE BETWEEN THE 2940-090 & 2940-091 MOUNTING KITS

PARTS IDENTIFICATION

2940-106

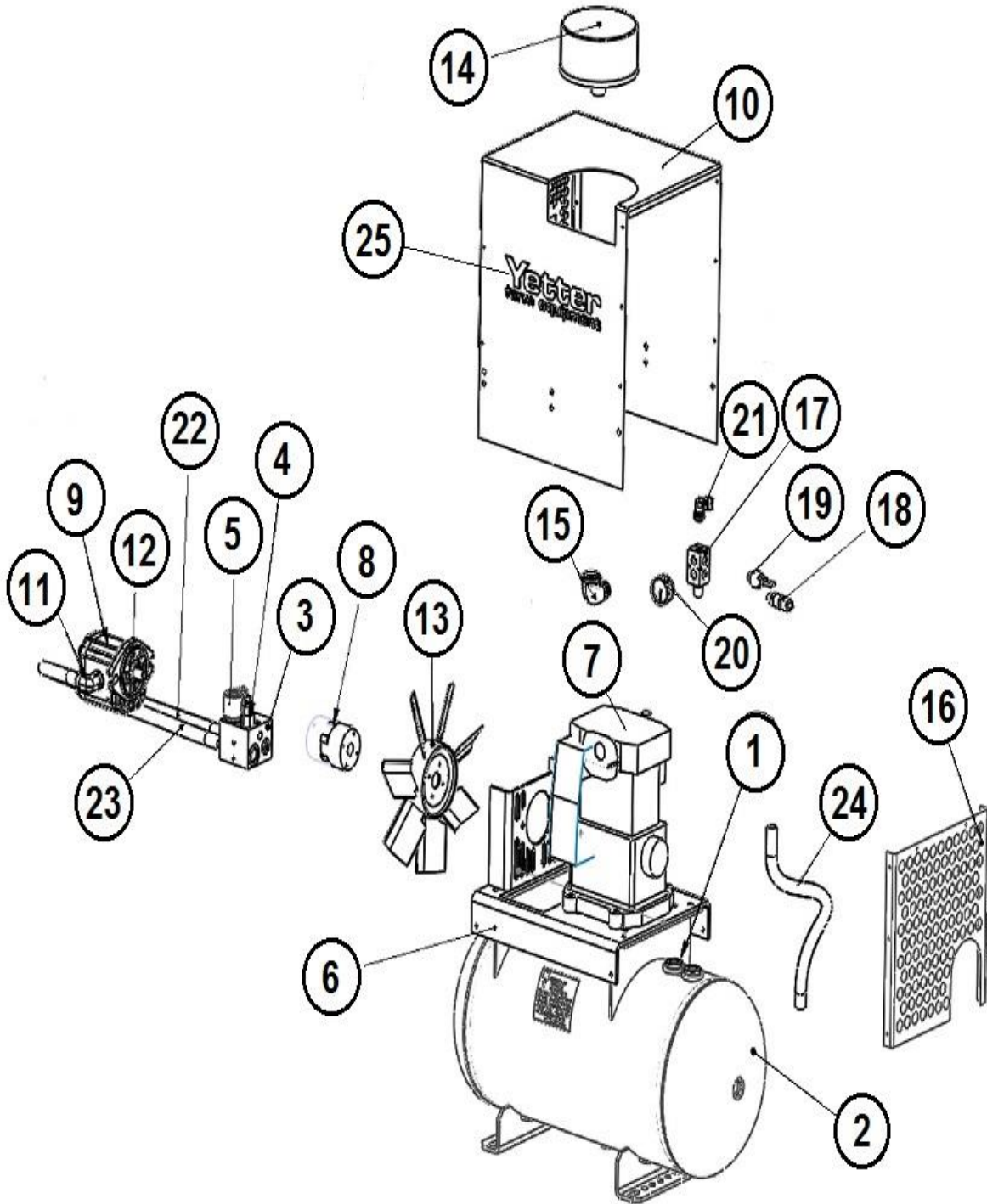

PARTS IDENTIFICATION

BALLOON	DESC
1	CHECK VALVE
2	TANK (12 GALLON)
3	VALVE BLOCK
4	FLOW CONTROL
5	VALVE
6	FRAME
7	PUMP
8	COUPLER
9	MOTOR
10	COVER
11	TANK ELBOW FITTING
12	INLET ELBOW FITTING
13	FAN
14	FILTER
15	FILTER ELBOW
16	BACK GUARD
17	AIR MANIFOLD
18	PRESSURE RELIEF VALVE
19	PRESSURE SWITCH
20	GAUGE
21	AIR ELBOW FITTING
22	TANK HOSE
23	INLET HOSE
24	PRESSURE LINE
25	YETTER DECAL

PART REFERENCE ONLY

PARTS IDENTIFICATION

ROLAIR
SCHEMATIC FOR
PMP12MK103

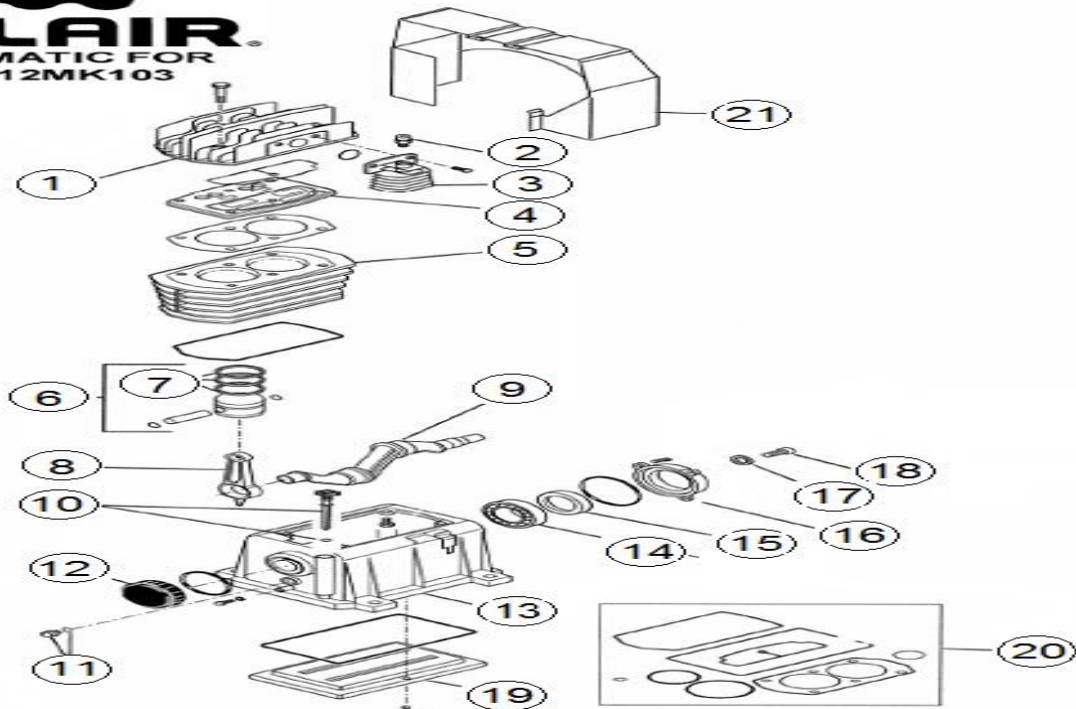

ROLAIR
S Y S T E M S

PARTS LIST FOR PMP12MK103

Schematic #	Description	Part #	Qty.
1	Head	FC113167020	1
2	Cold Start Valve	FC011158000	1
3	Aftercooler	FC116091024	1
4	Valve Plate Assembly	FC413167005	1
5	Cylinder	FC113167002	1
6	Complete Piston Assembly	FC413167006	2
7	Ring Set (2 required)	FC213167001	2
8	Connecting Rod	FC113150004	2
9	Crankshaft	FC113167003	1
10	Dipstick	FC312036000	1
11	Sight Gauge	FC012029000	1
12	End Cover	FC113149009	1
13	Crankcase	FC113167001	1
14	Ball Bearing	FC033027000	1
15	Oil Seal	FC010053000	1
16	Bearing Carrier	FC113149008	1
17	Washer	FC014005001	1
18	Bolt (Left-Hand Thread)	FC014001057	1
19	Lower Cover	FC113149015	1
20	Gasket Set	FC213167002	1
21	Shroud	FC113150002	1

PART REFERENCE ONLY

2940-103

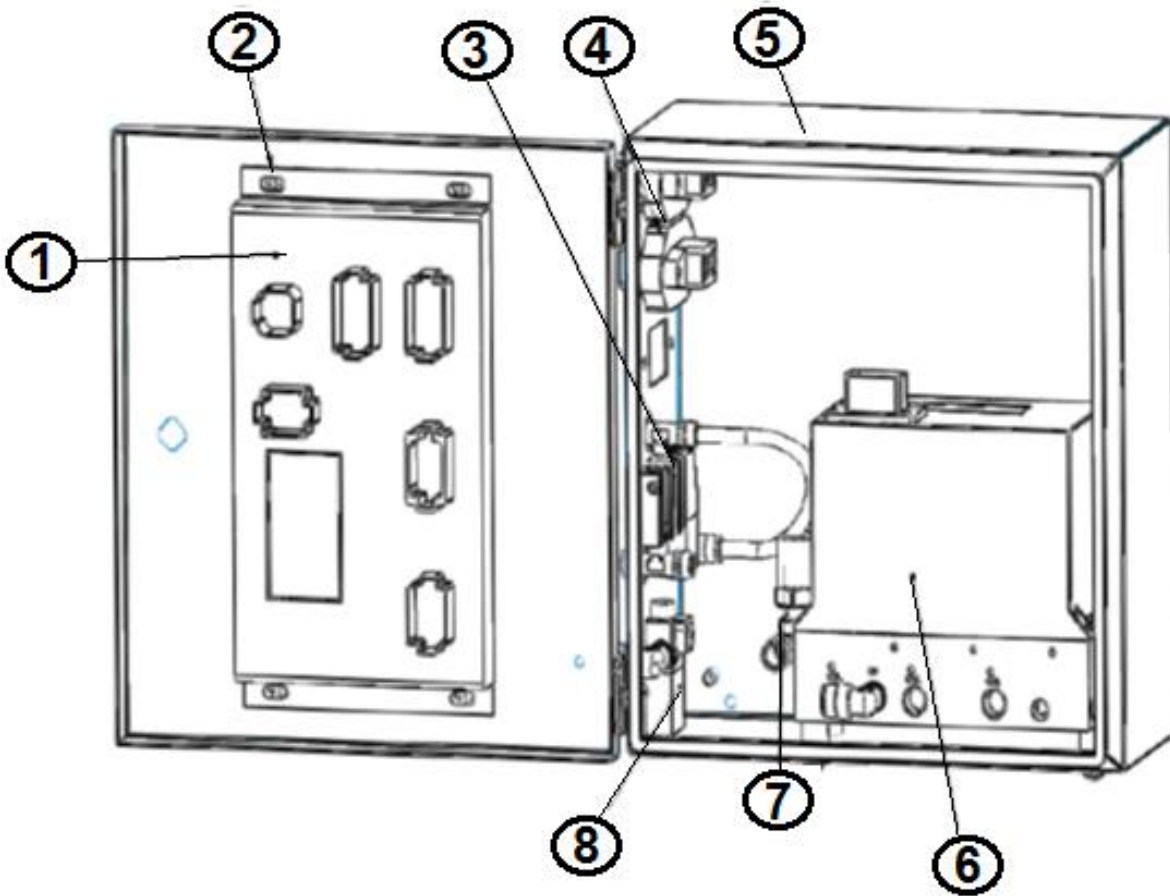

#	P/N	Description	Qty
1	2940-112	VDM	1
2	2940-442	SPACERS	4
3	2940-139	PRESSURE ON VALVE	1
4	HARNESS	HARNESSING	2
5		ENCLOSURE	1
6	2940-402	PQE	1
7	2940-441	PRESSURE TRANSDUCER	1
8	2940-431	WATER SEPARATOR DUMP VALVE	1

PARTS IDENTIFICATION

2940-136 Dump Valve Kit

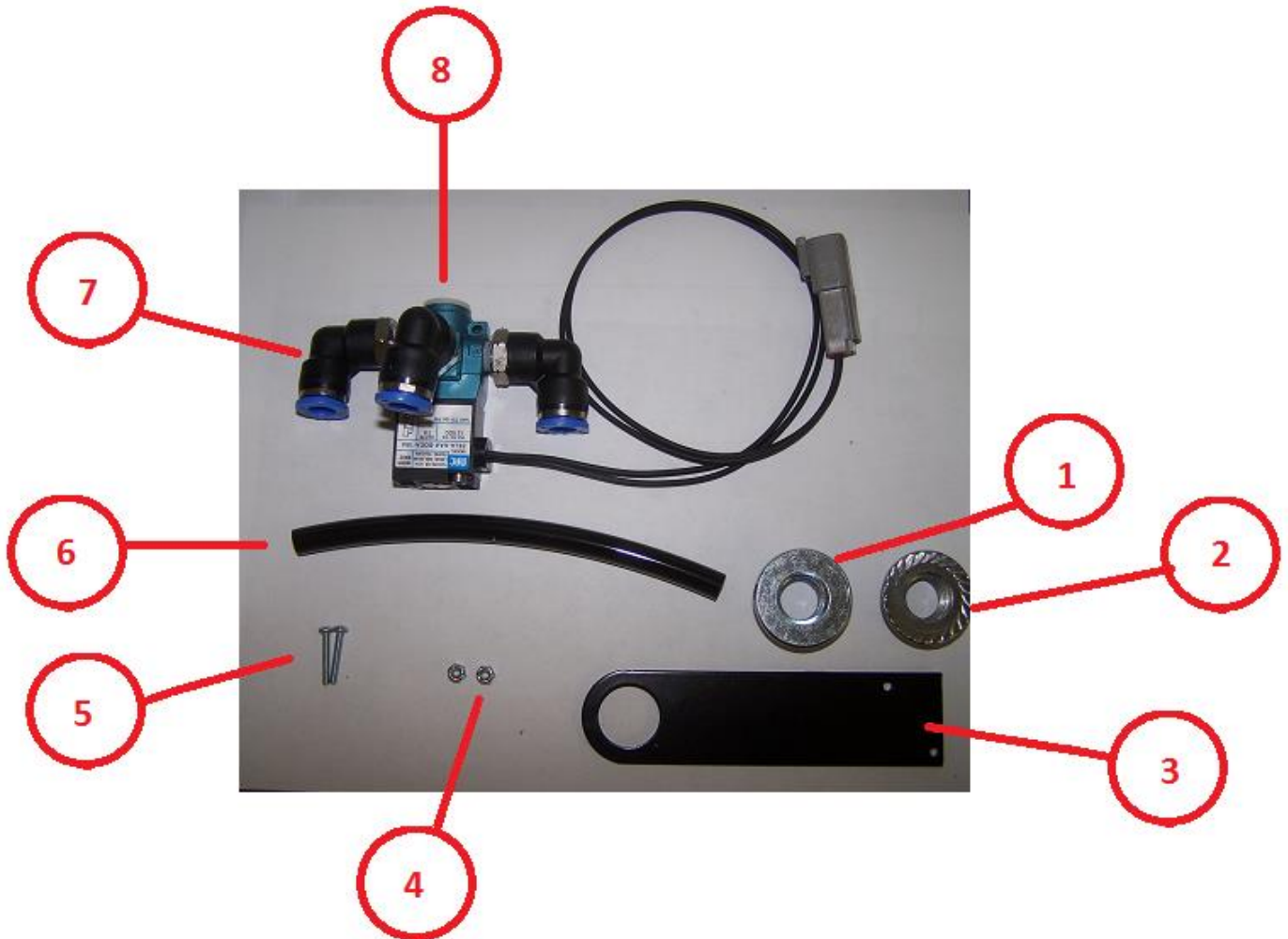

1. 14M7291 Metric Flange Hex Nut
2. 2520-464 5/8" Flange Hex Nut
3. 2940-335 Dump Valve Mount Tab
4. 2520-110 Lock Hex Nut
5. Bolt
6. 2940-138 3/8" Drain tube
7. 2940-337 3/8" Push Connect Elbow 1/8" NPT Male Thread
8. 2940-336 Dump Valve

Troubleshooting Guide

Problem	Cause	Corrective Action
Tank pressure drops when compressor shuts off	<ol style="list-style-type: none"> 1. Improper check valve function 2. loose connections/ air leak 3. water separator drain valve leaking 	<ol style="list-style-type: none"> 1. replace check valve 2. perform leak check(see page x) 3. replace water separator drain valve
Compressor runs continuously/air flow lower than normal, Compressor Run Time High warning on cab controller if compressor runs continuously for 15 minutes	<ol style="list-style-type: none"> 1. excessive air usage 2. loose connections/air leak 3. Improper pressure switch function 4. clogged air filter element 5. worn compressor 6. defective safety valve 7. tank drain valve open 8. water separator valve leaking 	<ol style="list-style-type: none"> 1. decrease air usage 2. perform leak check(see page x) 3. replace pressure switch 4. clean/replace filter element 5. replace compressor 6. replace safety valve 7. close tank drain valve 8. replace water separator valve
Compressor will not run	<ol style="list-style-type: none"> 1. air system is off 2. hydraulics disengaged 3. no power to the VDM 4. Communication harness connection issue 5. shut off psi(145psi) reached 6. worn compressor 7. pressure switch failure 	<ol style="list-style-type: none"> 1. press enter to activate system(AIR ON) 2. engage compressor hydraulic circuit 3. check power connections from battery to VDM, check breaker on the 2940-166 4. check harnessing from cab controller to the control box 5.compressor will restart after tank pressure drops below 125psi 6. replace compressor 7. replace pressure switch
No air output from the RU, RD, and WT ports even though pressure is commanded and tank pressure reads 60psi or greater	<ol style="list-style-type: none"> 1. air system is off 2. no power to the VDM 3. J3 connector on VDM plugged in upside down 4. Improperly functioning PQE 5. communication harness connection issue 	<ol style="list-style-type: none"> 1. press enter to activate system(AIR ON) 2. check power connections from battery to VDM, check breaker on the 2940-166 3.unplug J3 connector, check tab/slot sizes, reinstall J3 connector properly 4. replace PQE 5. check the end of all connectors to make sure terminal pins are all seen on the end of the male connectors and the connectors are seated tightly
Low or sporadic tank pressure reading Air leaking out regulator knob	water separator/regulator assembly plumbed incorrectly	plumb water separator/regulator correctly (air compressor→water separator→exit regulator side→enter control box inlet port)
Compressor struggles to build/won't build 145psi	flow control valve adjustment needed	See page 71 for instructions on flow control valve adjustments
No ECU/VDM present displays on Cab Controller	Improper communication harness connection between cab controller and VDM	start at the 6 pin connector on the back of the cab controller and inspect all connectors and connections to the VDM
Excessive noise from compressor	<ol style="list-style-type: none"> 1. Loose mounting bolts 2. Worn bearings 3. Cylinder or piston is worn 	<ol style="list-style-type: none"> 1. Tighten bolts 2. Replace compressor 3. Rebuild compressor
Excessive moisture in discharge	<ol style="list-style-type: none"> 1. Excessive water in air tank 2. High humidity 	<ol style="list-style-type: none"> 1. Drain tank, drain tank more frequently 2. Move compressor to area with less humidity.
Excessive noise from compressor	<ol style="list-style-type: none"> 1. Loose mounting bolts 2. Worn bearings 3. Cylinder or piston worn 	<ol style="list-style-type: none"> 1. Tighten bolts 2. Replace compressor 3. Rebuild compressor
Hydraulic motor front seal leakage	<ol style="list-style-type: none"> 1. Case drain clogged or unplugged 2. Case drain not plumbed correctly 	<ol style="list-style-type: none"> 1. Remove case drain plumbing and clean out debris/obstruction, replace seal 2. Plumb case drain according to the instructions on page 25, replace seal
The 2940-162 Dump Valve Harness is not labeled on the 4) 2 pin pigtails	Labels missing on the 2 pin cables on the harness	Label as follows: RM UP DUMP → Yellow/Black RM DOWN DUMP → Orange/Black AUX 3 → White/Black AUX 4 → Purple/Black

NOTES:

NOTES:

NOTES:

Our name Is getting known

Just a few years ago, Yetter products were sold primarily to the Midwest only. Then we embarked on a program of expansion and moved into the East, the South, the West and now north into Canada. We're even getting orders from as far away as Australia and Africa.

So, when you buy Yetter products . . .you're buying a name that's recognized. A name that's known and respected. A name that's become a part of American agriculture and has become synonymous with quality and satisfaction in the field of conservation tillage.

Thank you.

2565-779_REV_C • 02/15

YETTER MANUFACTURING CO.
Colchester, IL 62326-0358 • 309/776-4111
Toll Free 800/447-5777
Fax 309/776-3222
Website: WWW.YETTERCO.COM
E-MAIL: INFO@YETTERCO.COM